

ASSEMBLY INSTRUCTIONS

ROUND TABLE



WF296298





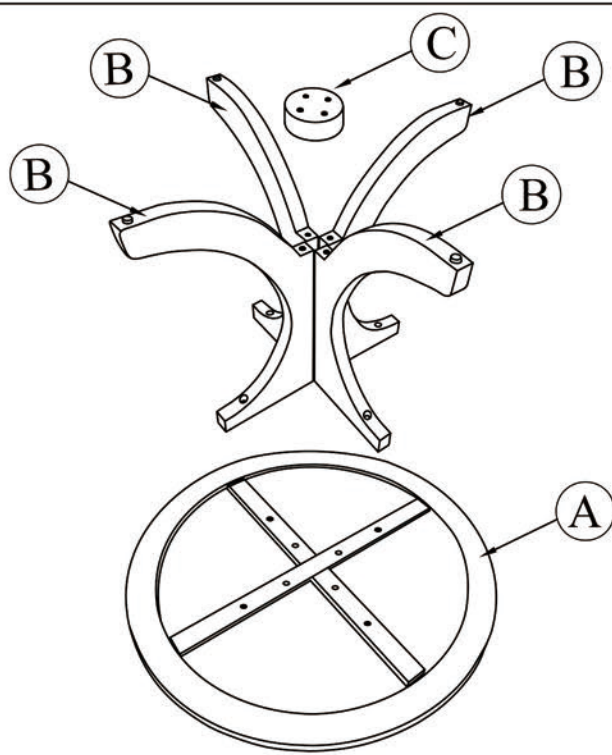

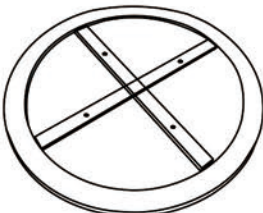

IMPORTANT NOTE:

- ① PLACE ALL PARTS ON A CLEAN AND SMOOTH SURFACE SUCH AS A RUG OR CARPET TO AVOID THE PARTS FROM BEING SCRATCHED.
- ② BEFORE YOU BEGIN, KINDLY FOLLOW THE ASSEMBLY INSTRUCTIONS STEP BY STEP.
- ③ DO NOT TIGHTEN ALL SCREWS AND BOLTS UNTIL THE TABLE IS FULLY SET-UP

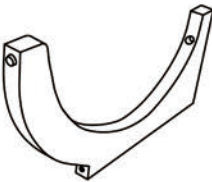

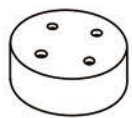
Part List For One

Hardware List For One

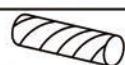
<p>A</p>  <p>Table Top (1pc)</p>	<p>1</p>  <p>5/16" x 60mm BOLT (4PCS)</p>
<p>B</p>  <p>Legs (4pcs)</p>	<p>2</p>  <p>5/16" x 40mm BOLT (4PCS)</p>
<p>C</p>  <p>Support Wood (1PC)</p>	<p>3</p>  <p>5/16" x 13mm SPRING WASHER (8PCS)</p>
	<p>4</p>  <p>5/16" x 19mm FLAT WASHER (8PCS)</p>
	<p>5</p>  <p>4mm ALLEN KEY (1PC)</p>
	<p>6</p>  <p>Ø10mm x 40mm DOWEL (4PCS)</p>

STEP 1

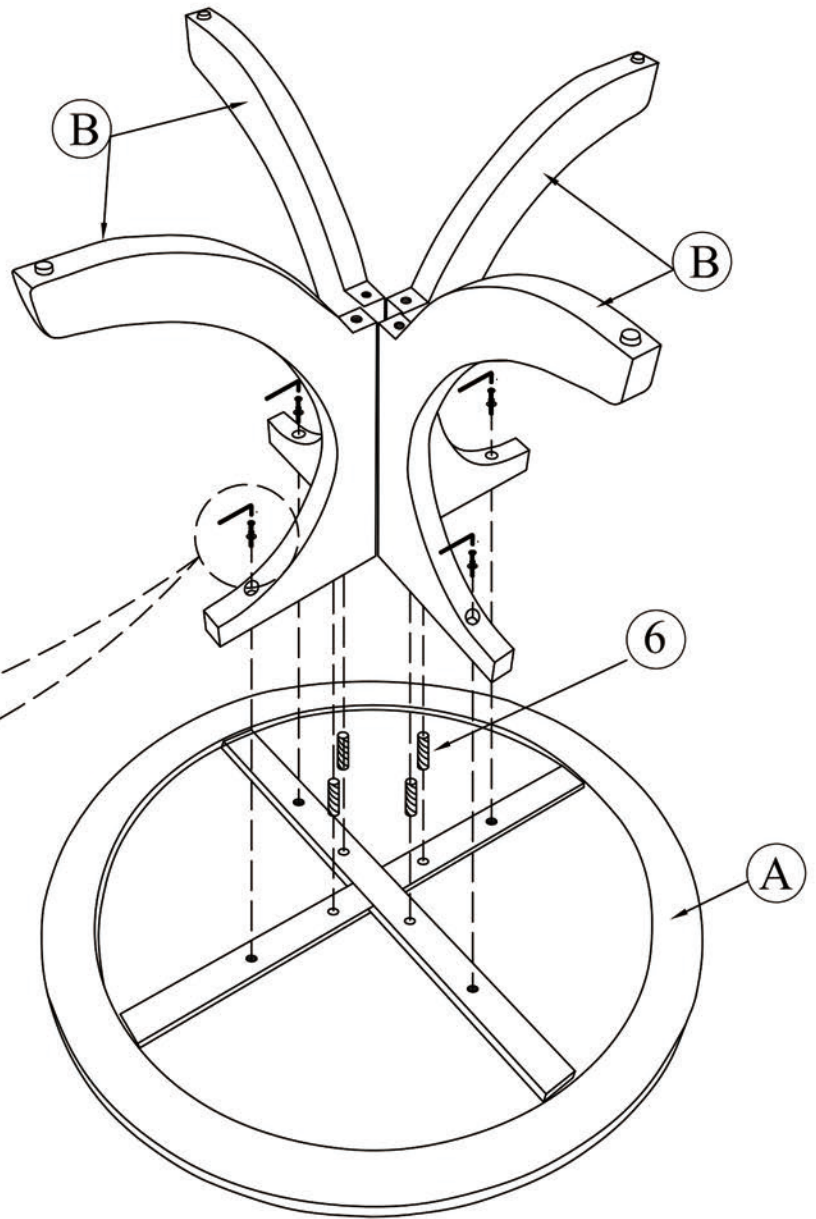
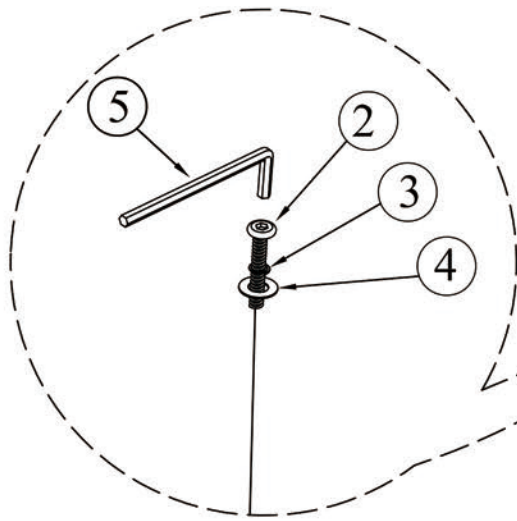

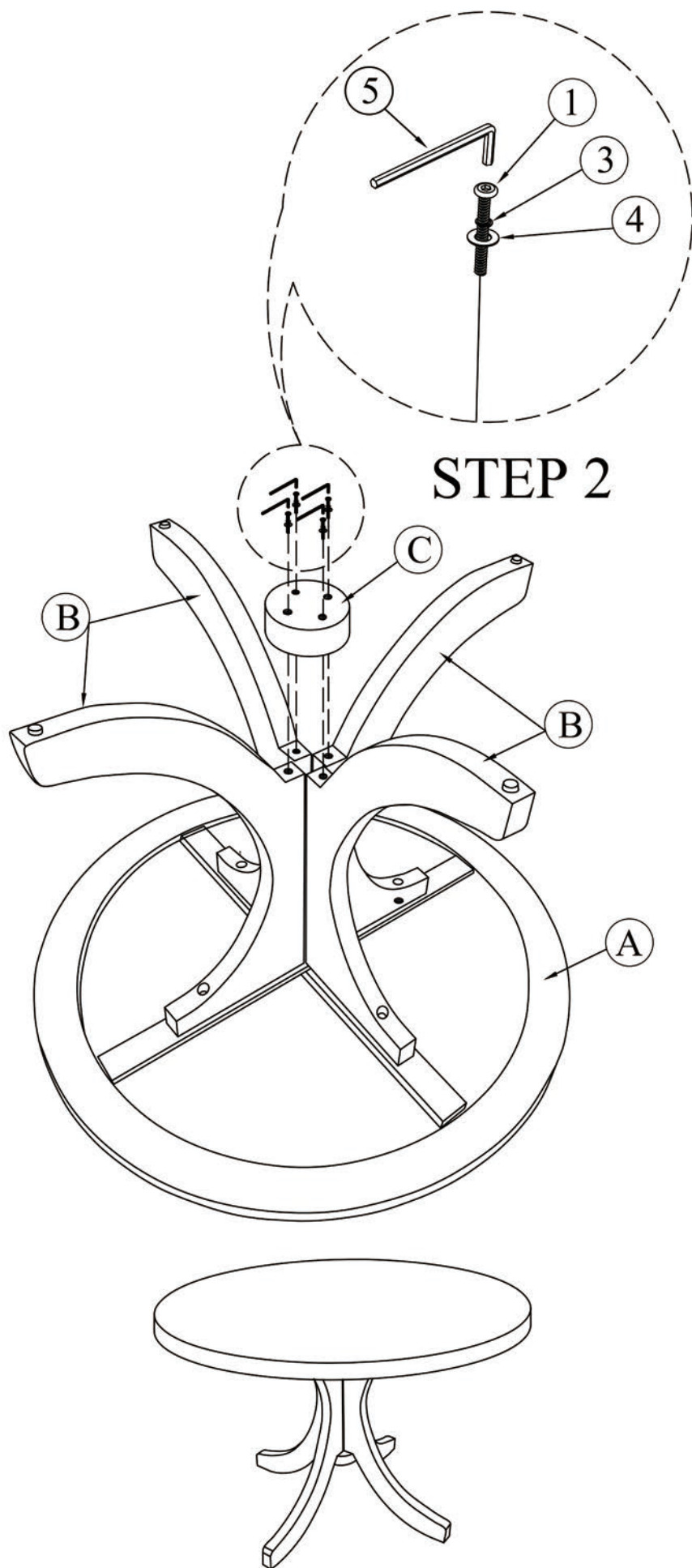

STEP 2

ASSEMBLY INSTRUCTIONS

DINING CHAIR

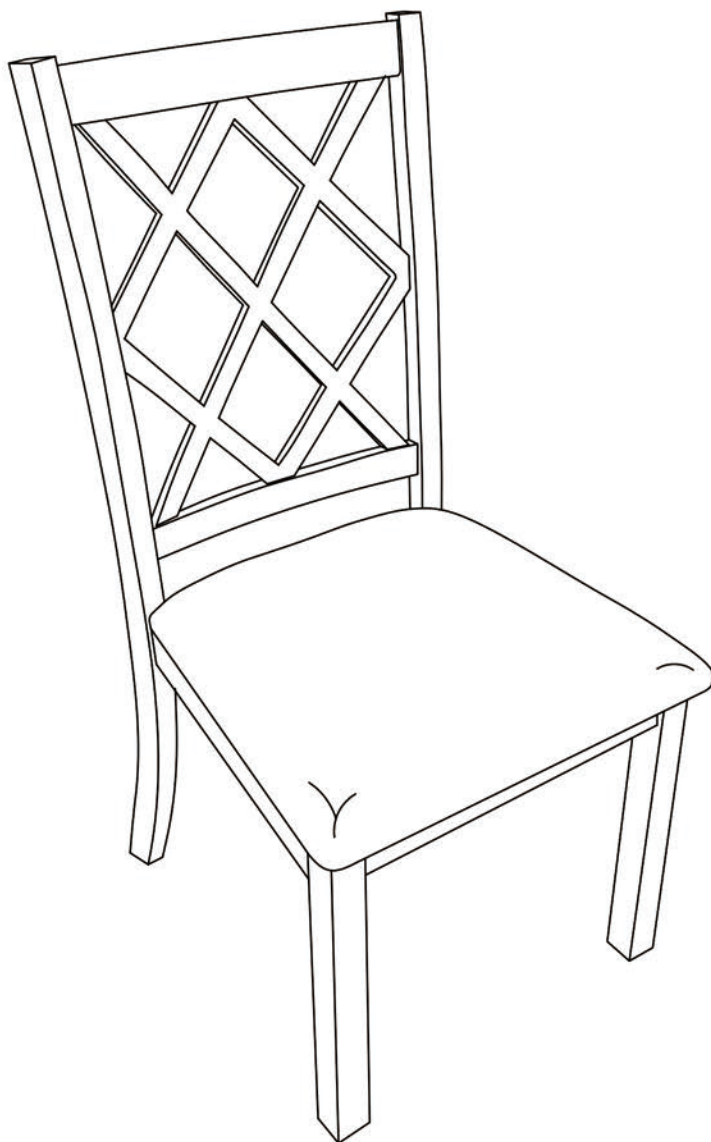







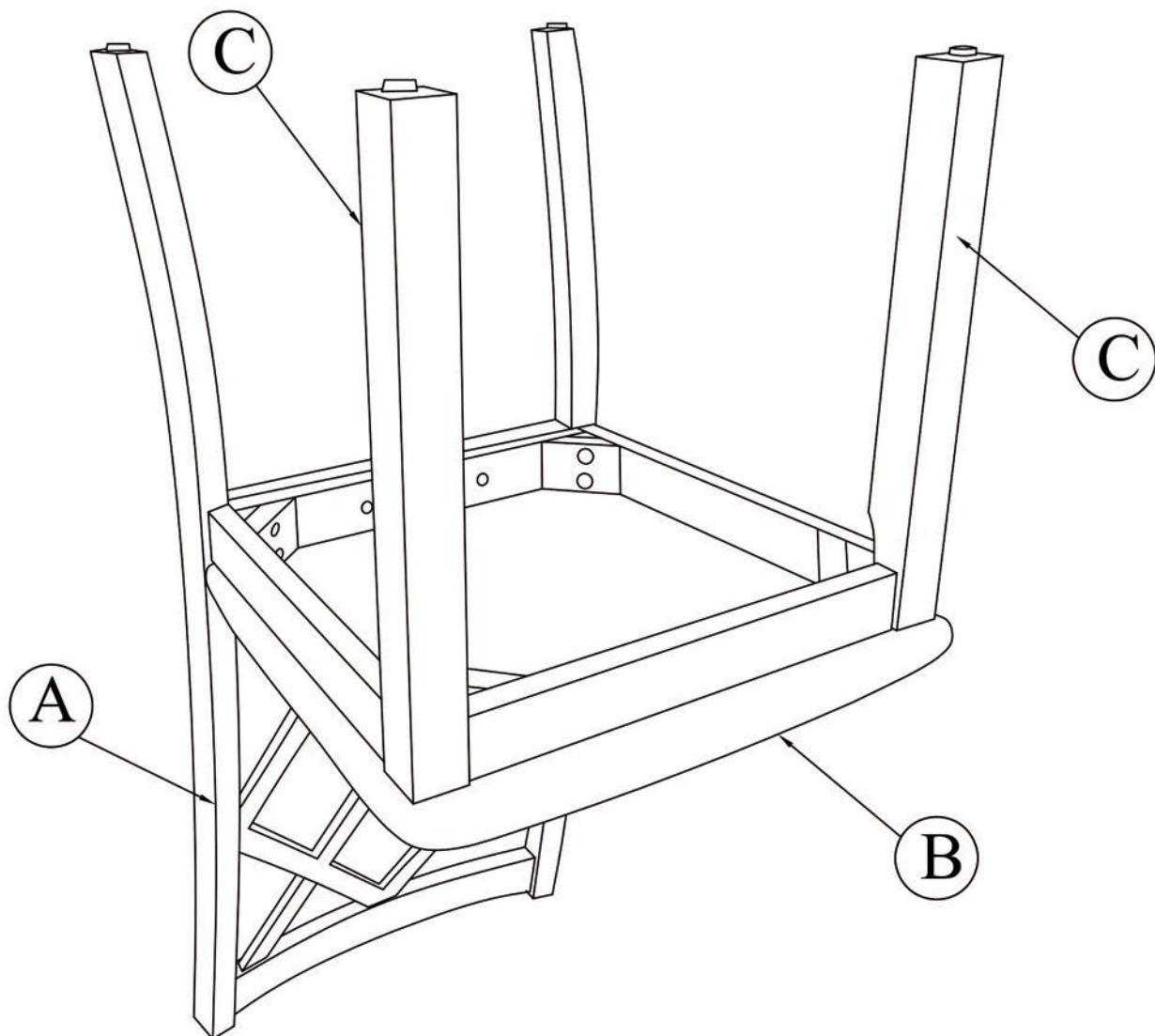

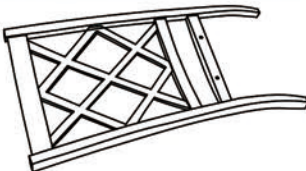

WF296299

IMPORTANT NOTE:

- ① PLACE ALL PARTS ON A CLEAN AND SMOOTH SURFACE SUCH AS A RUG OR CARPET TO AVOID THE PARTS FROM BEING SCRATCHED.
- ② BEFORE YOU BEGIN, KINDLY FOLLOW THE ASSEMBLY INSTRUCTIONS STEP BY STEP.
- ③ DO NOT TIGHTEN ALL SCREWS AND BOLTS UNTIL THE CHAIR IS FULLY SET-UP



Part List For One			Hardware List For One		
No	Parts Desc.	Q'ty	No	Hardware Desc.	Q'ty
A	BACK FRAME 	1pc	1	Bolts 5/16"*35mm 	2pcs
			2	Bolts 5/16"*75mm 	4pcs
			3	Spring Washer 5/16"*13mm x 1.5mm 	6pcs
B	SEAT FRAME 	1pc	4	Flat Washer 5/16"*19mm x 1.5mm 	6pcs
			5	Bolts 1/4"*50mm 	4pcs
C	FRONT LEGS 	2pcs	6	Spring Washer 1/4"*11mm x 1.5mm 	4pcs
			7	Flat Washer 1/4"*16mm x 1.5mm 	4pcs
			8	Allen Key 4mm*60mm 	1pc

STEP 1

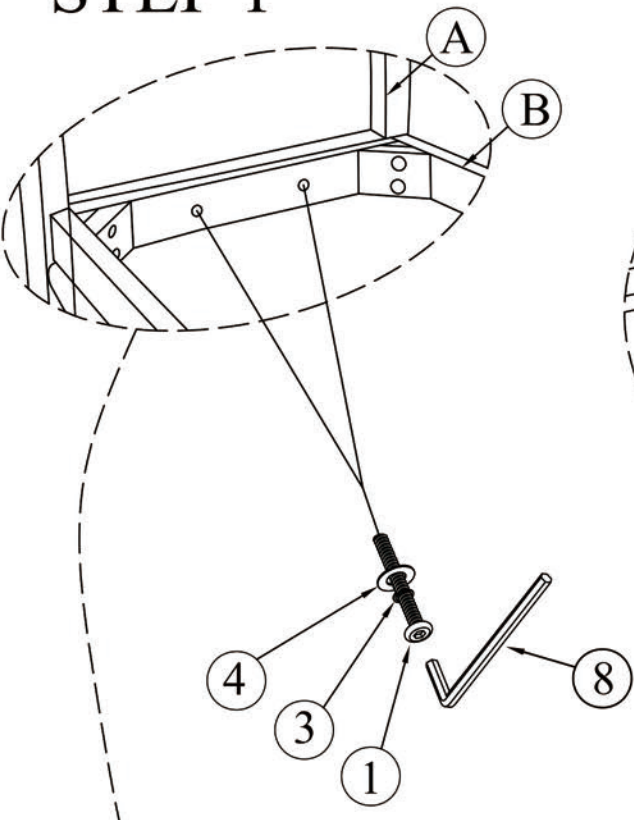

STEP 2

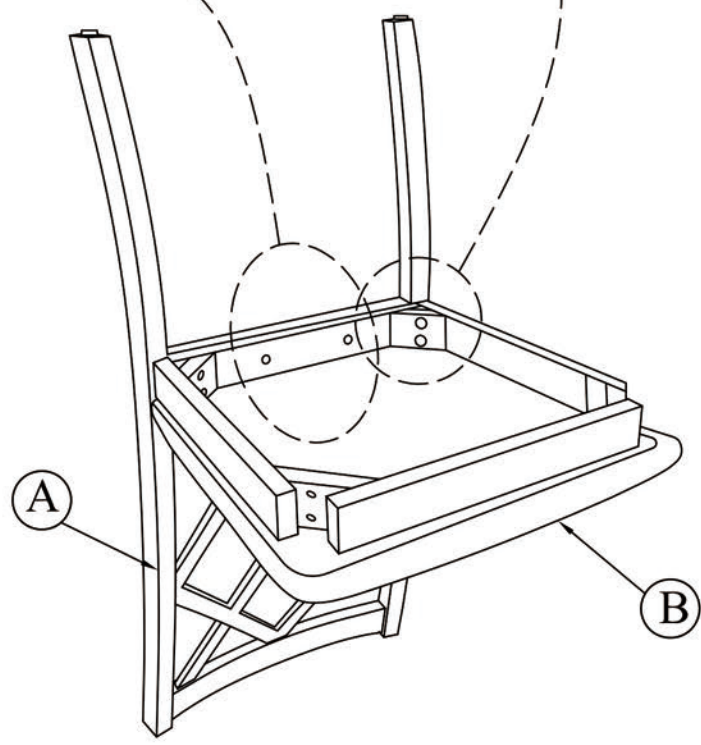
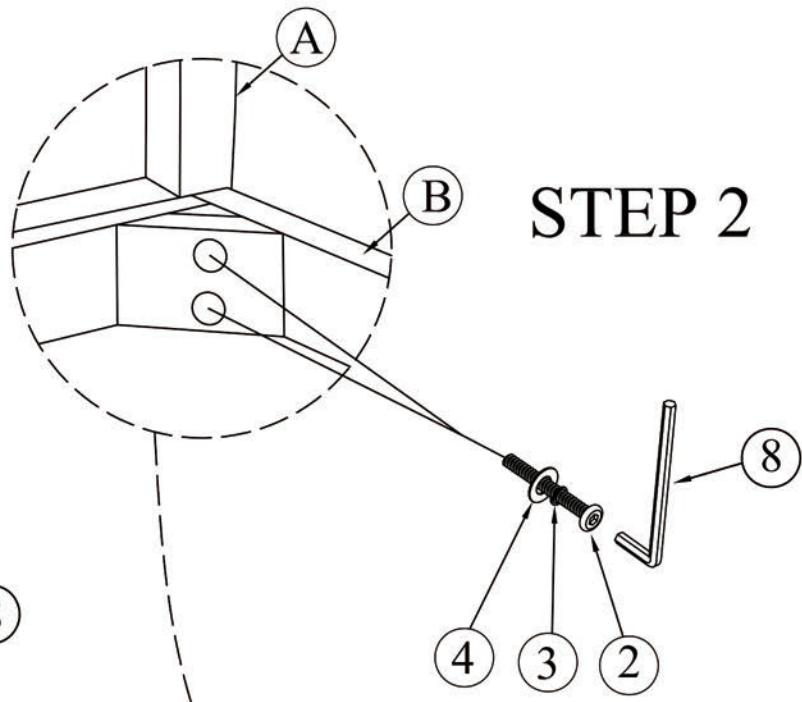

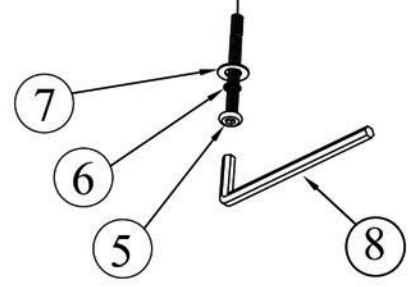
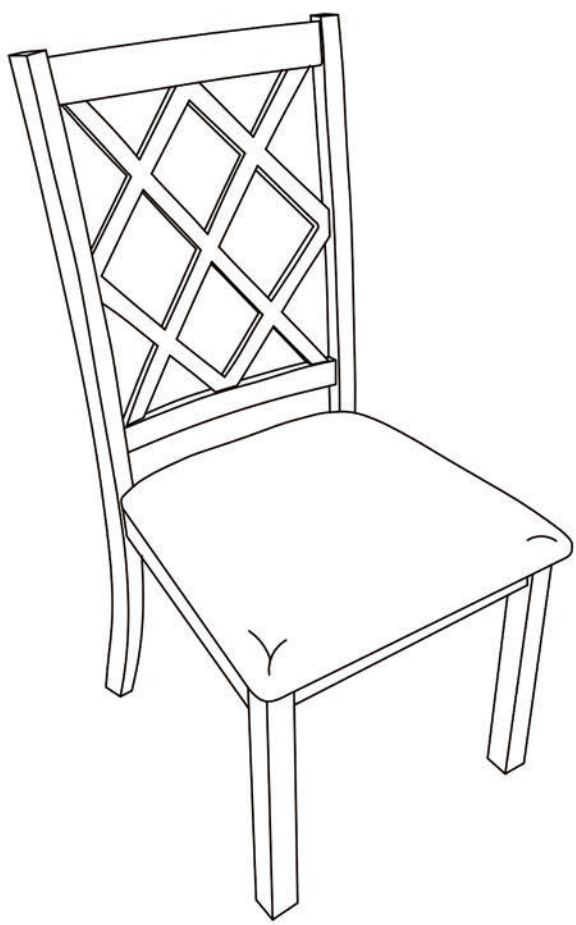
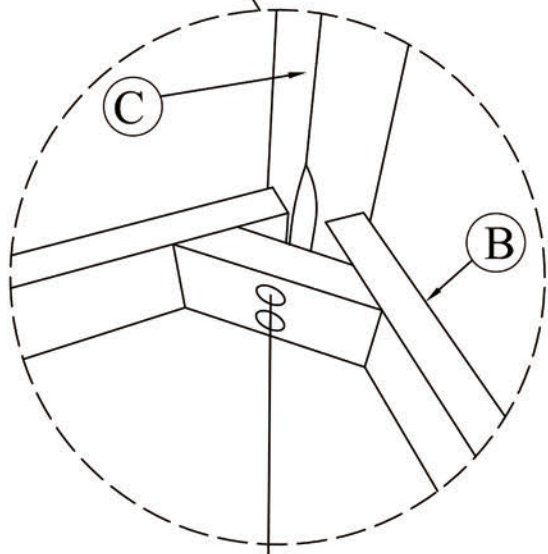
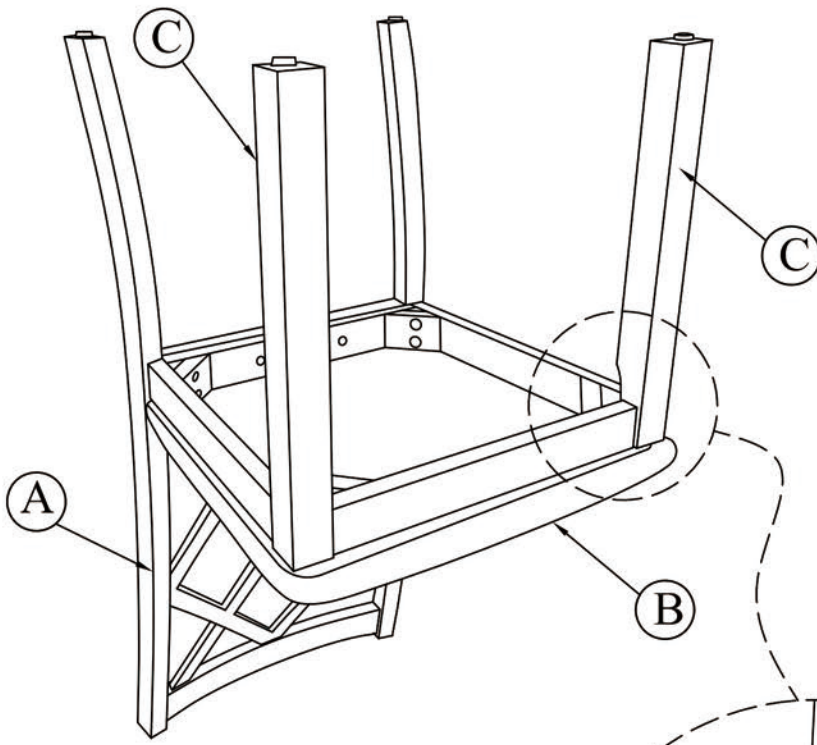

STEP 3