

ASSEMBLY INSTRUCTIONS

ITEM NO. FB3018ZD-TBE

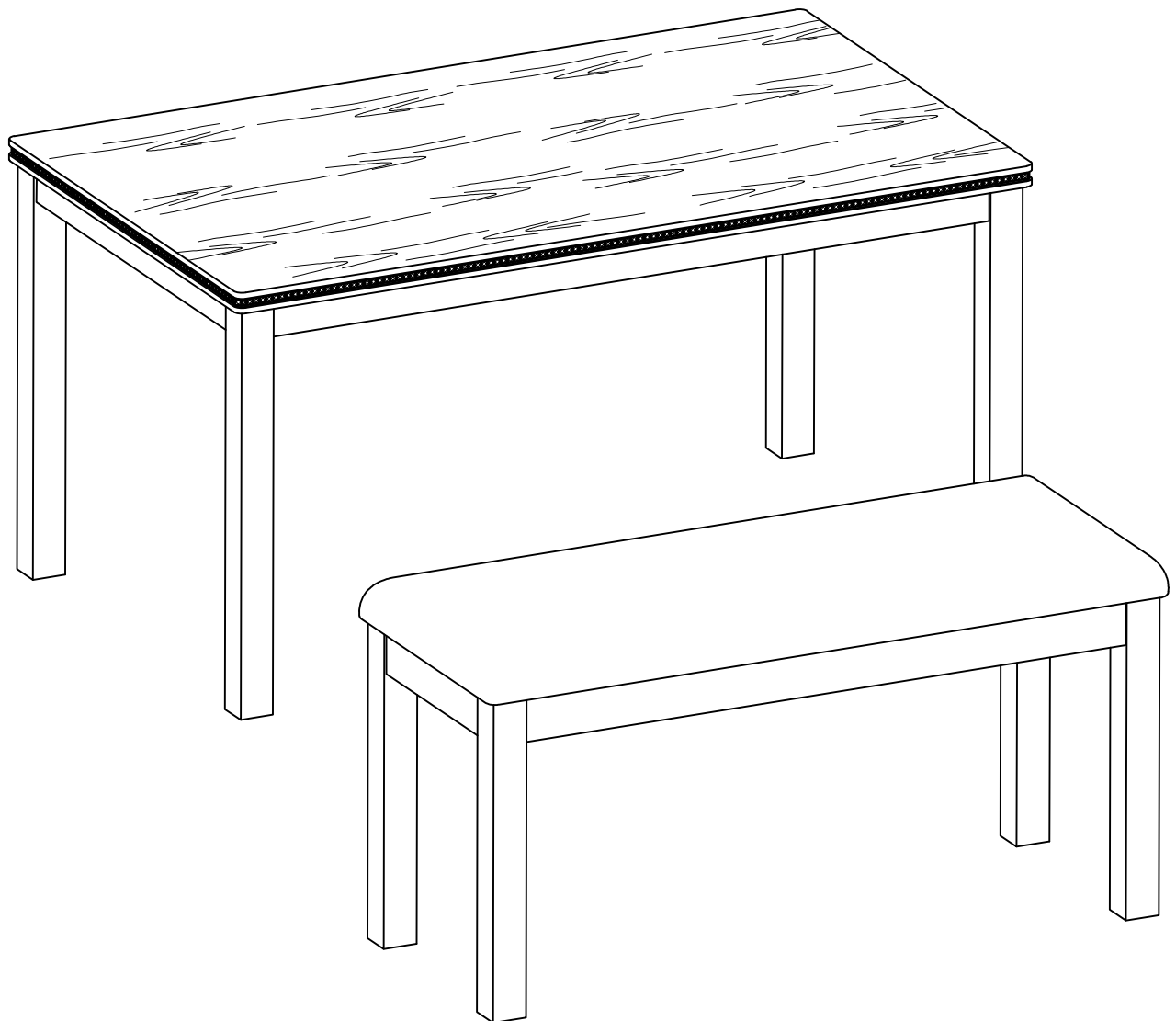



ASSEMBLY TIPS:

1. Remove hardware from box and sort by size.
2. Please check to see that all hardware and parts are present prior to start of assembly.
3. Please follow attached instructions in the same sequence as numbered to assure fast & easy assembly.

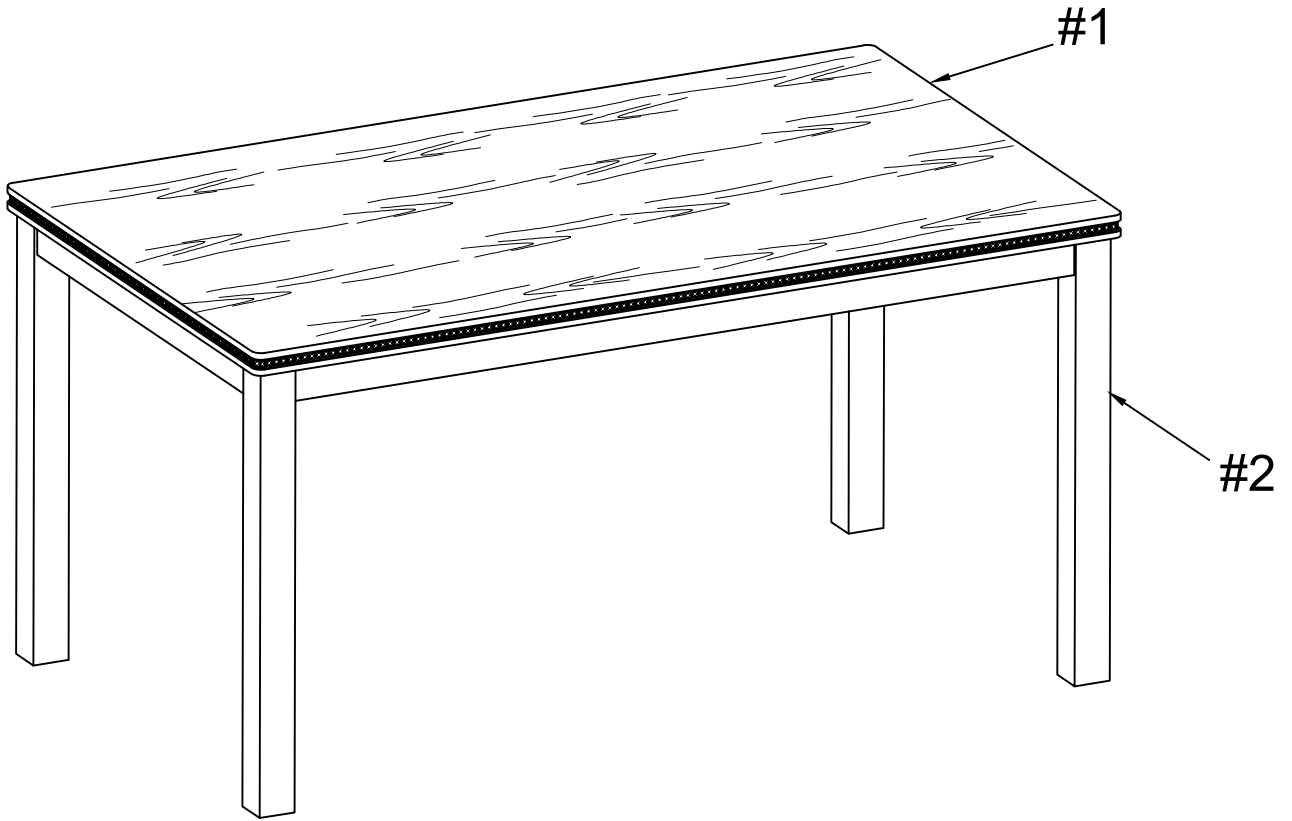

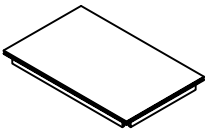

Exploded View

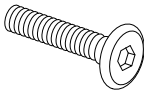

PARTS LIST

NO.	DIAGRAM	PART NAME	Q'Ty
1		Table Top	1PC
2		Table Leg	4PCS

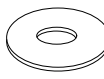
HARDWARE LIST

NO.	DIAGRAM	PART NAME	Q'Ty
A		Bolt M8 x 65mm	8PCS
B		Lock Washer M8	8PCS
C		Flat Washer M8x19mm	8PCS
D		Allen Key M4	1PC

STEP 1

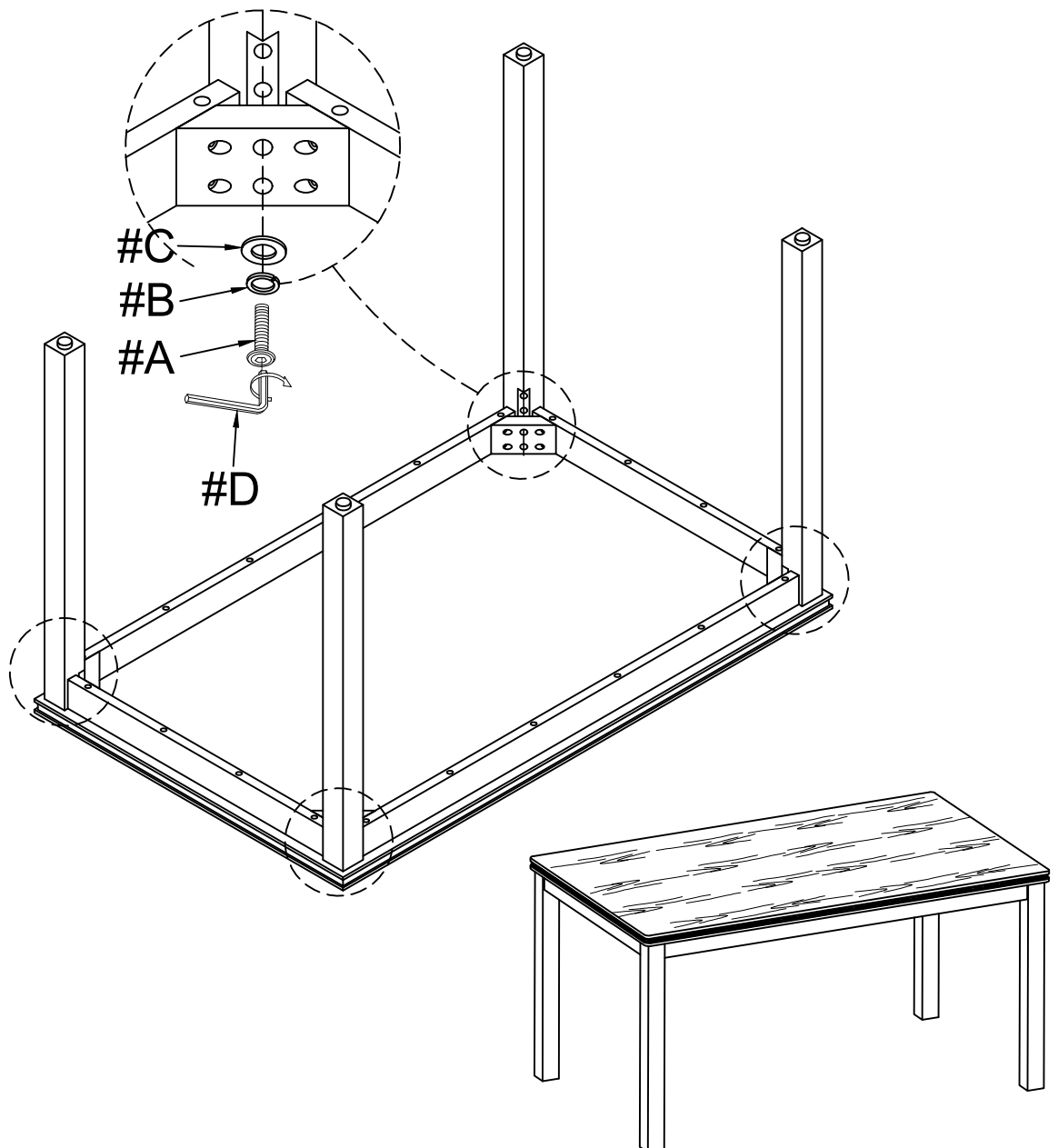



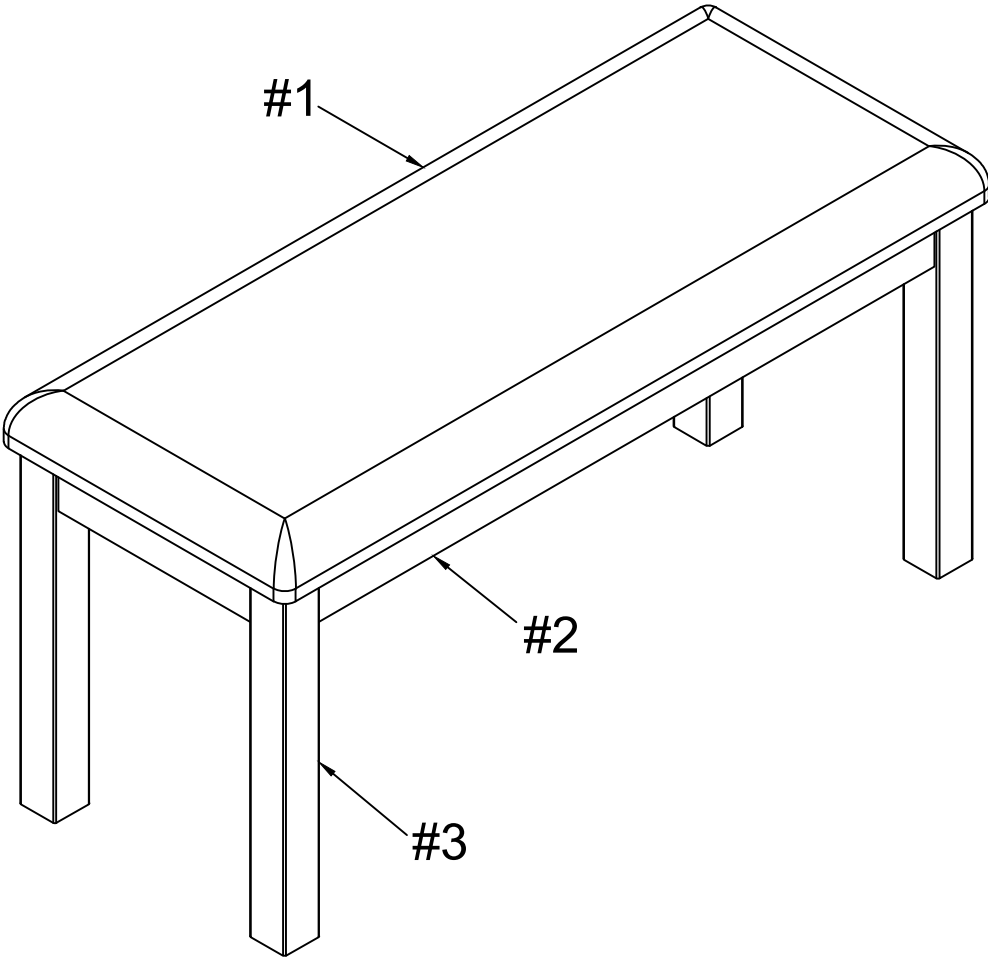

Exploded View

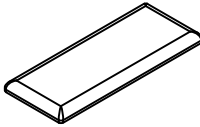
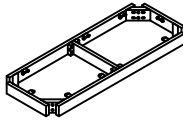
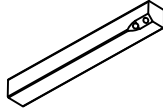

PARTS LIST

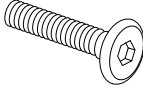
NO.	DIAGRAM	PART NAME	Q'Ty
1		Cushion	1PC
2		Seat Frame	1PC
3		Leg	4PCS

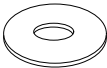
HARDWARE LIST

NO.	DIAGRAM	PART NAME	Q'Ty
A		Bolt M8 x 65mm	8PCS
B		Lock Washer M8	8PCS
C		Flat Washer M8x19mm	8PCS
D		Allen Key M4	1PC
E		Screws #3.5 *12mm	8PCS

STEP 1:

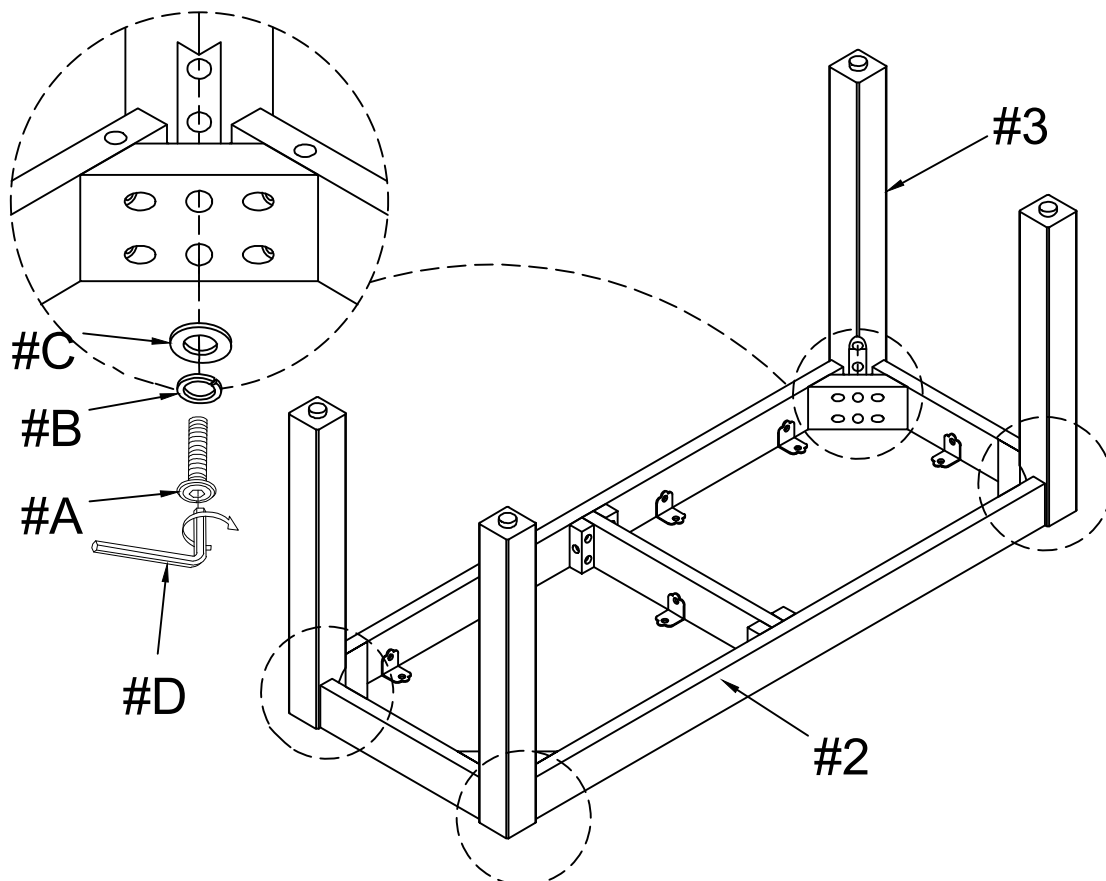

STEP 2

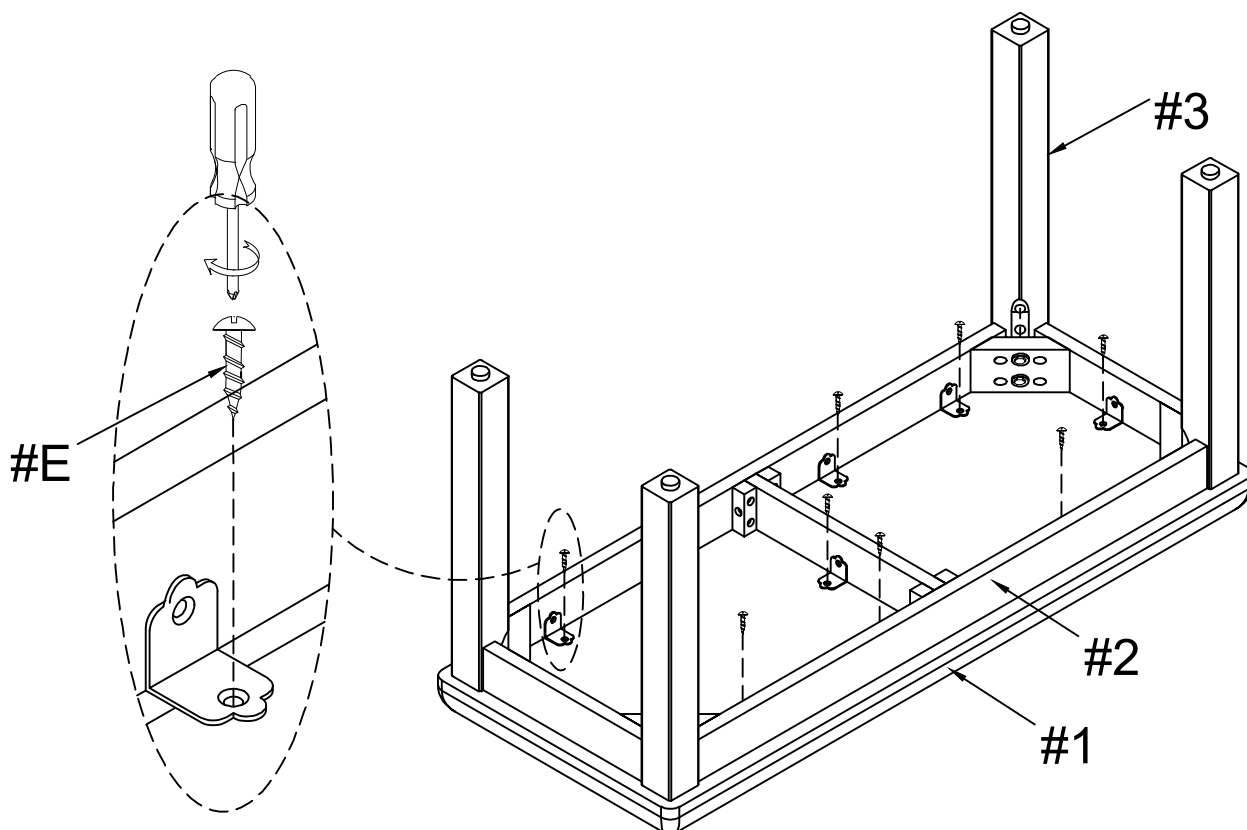

STEP 3

