

ASSEMBLY INSTRUCTIONS

ITEM NO. FB3020ZD-SC-4PK

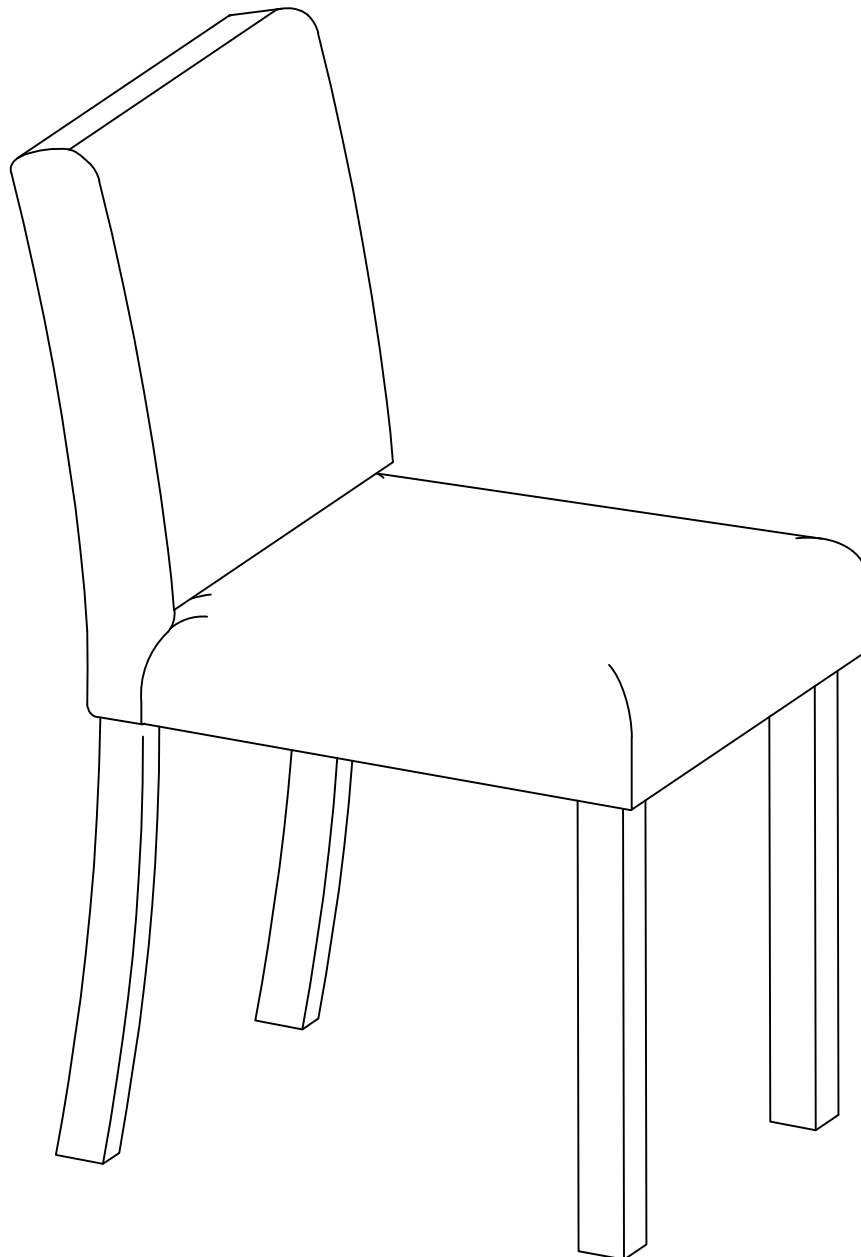



ASSEMBLY TIPS:

1. Remove hardware from box and sort by size.
2. Please check to see that all hardware and parts are present prior to start of assembly.
3. Please follow attached instructions in the same sequence as numbered to assure fast & easy assembly.

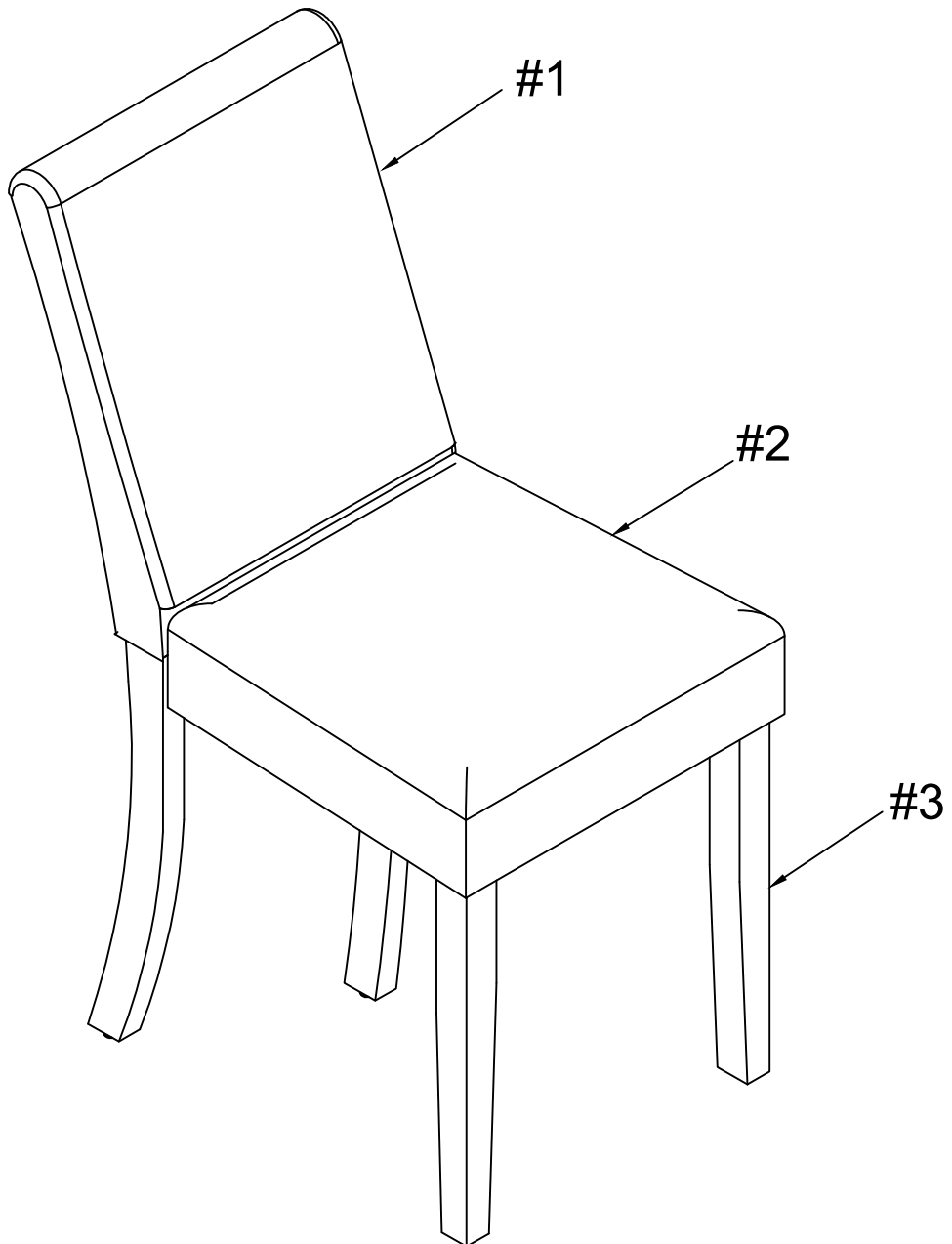

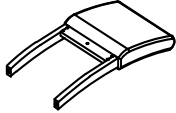
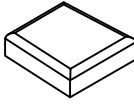

Exploded View



PARTS LIST

NO.	DIAGRAM	PART NAME	Q'Ty
1		Backrest	1PC
2		Chair Seat	1PC
3		Front Leg	2PCS

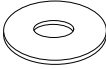
HARDWARE LIST

NO.	DIAGRAM	PART NAME	Q'Ty
A		Bolt M8 x 75mm	8PCS
B		Bolt M8 x 55mm	1PC
C		Lock Washer M8	9PCS
D		Flat Washer M8x19mm	9PCS
E		Allen Key M5	1PC

STEP 1

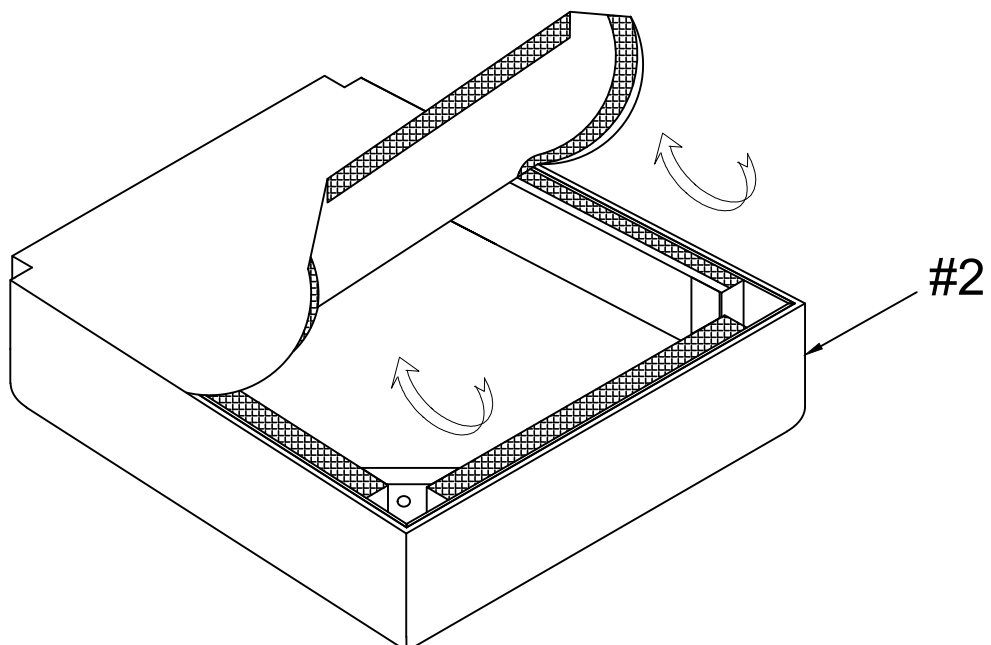

STEP 2

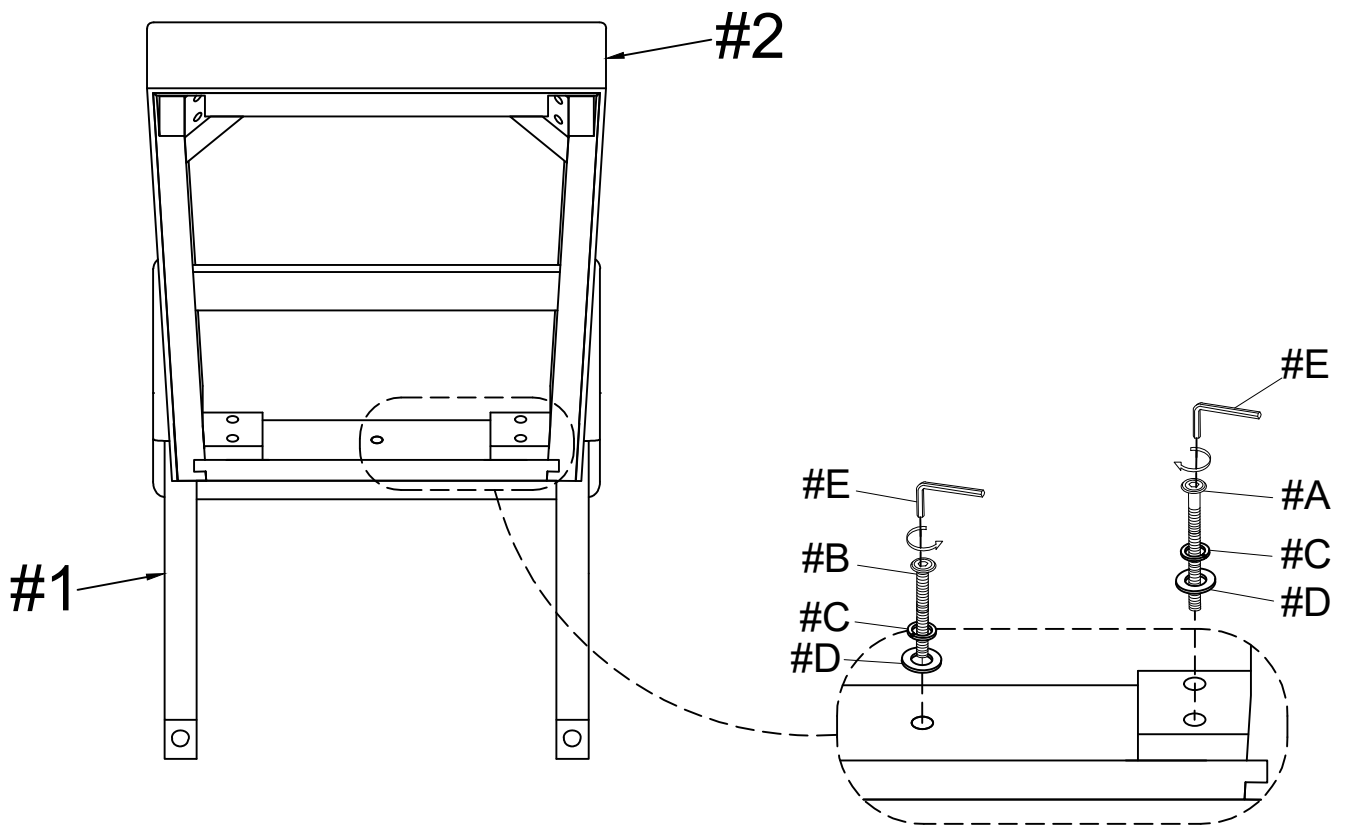

STEP 3

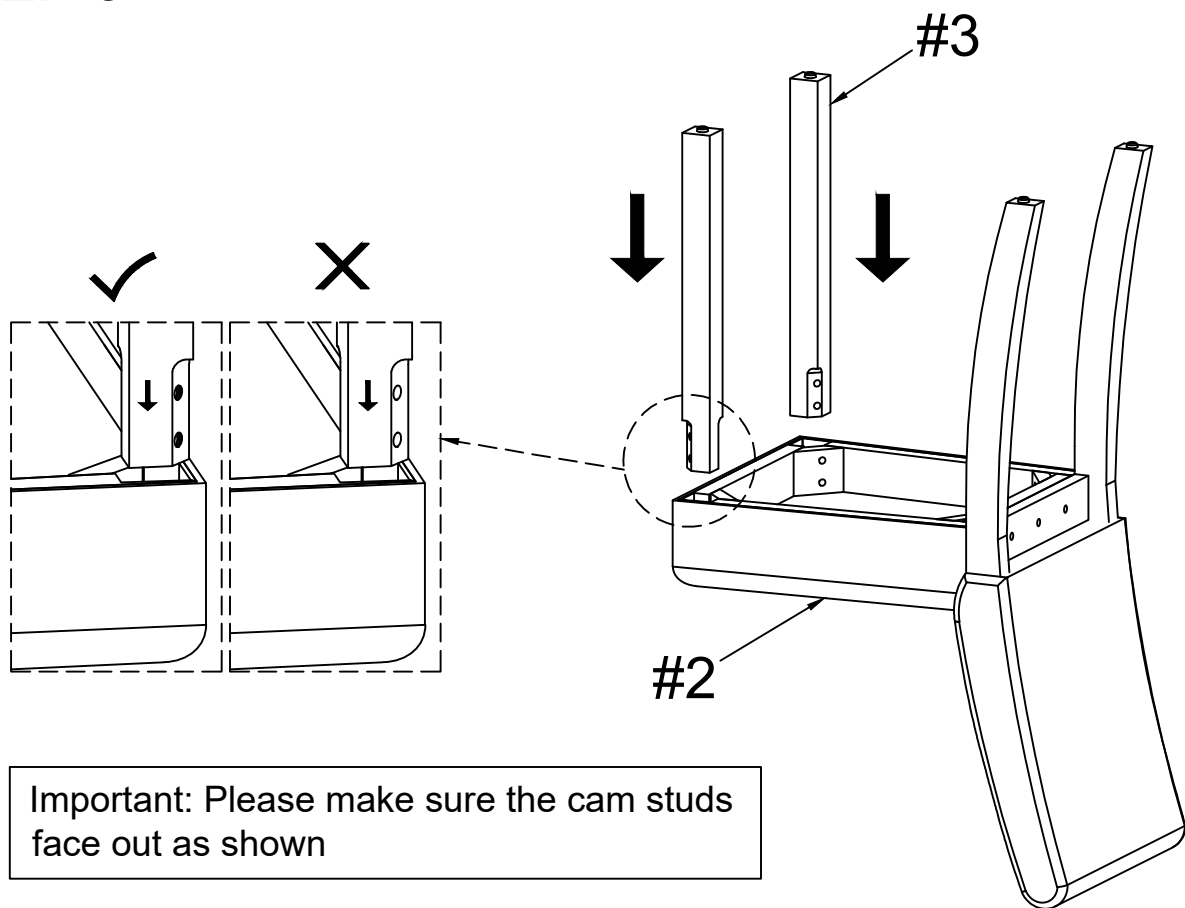

STEP 4

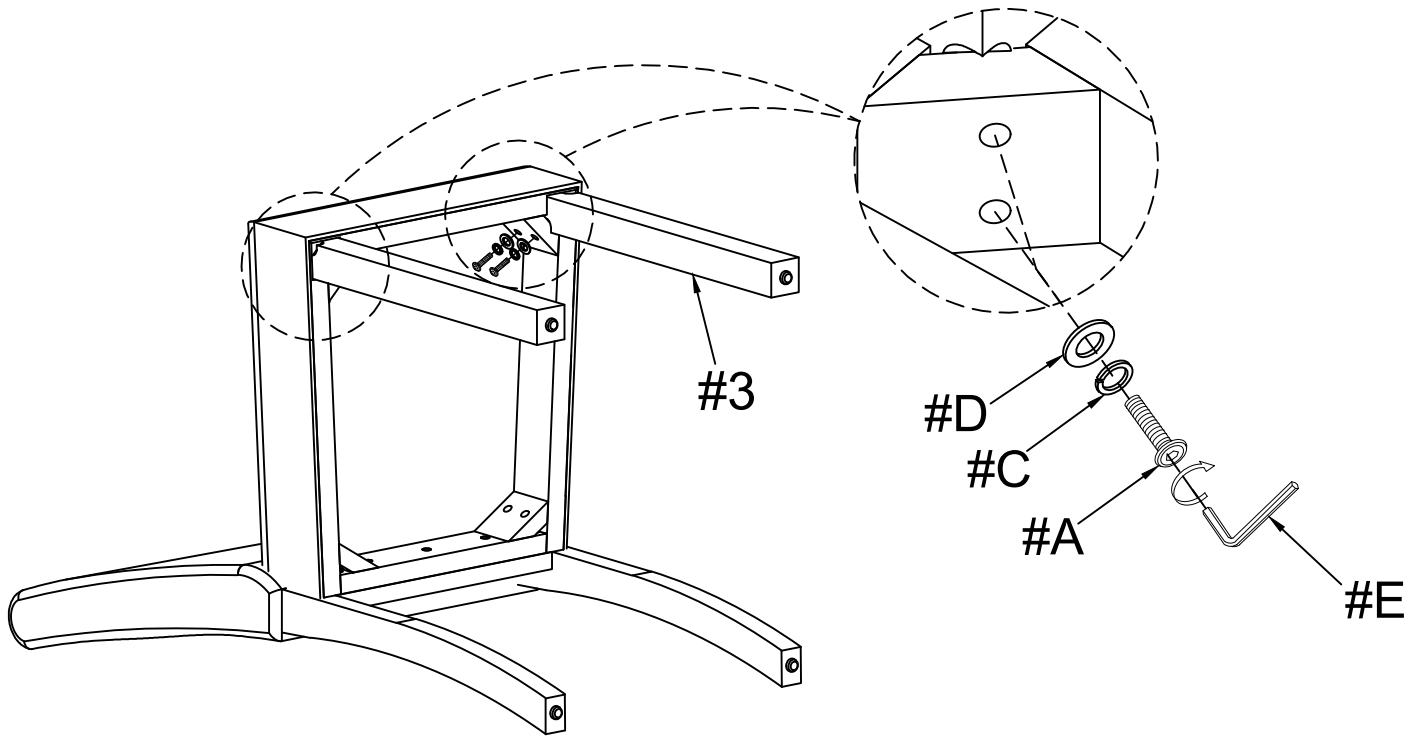

STEP 5

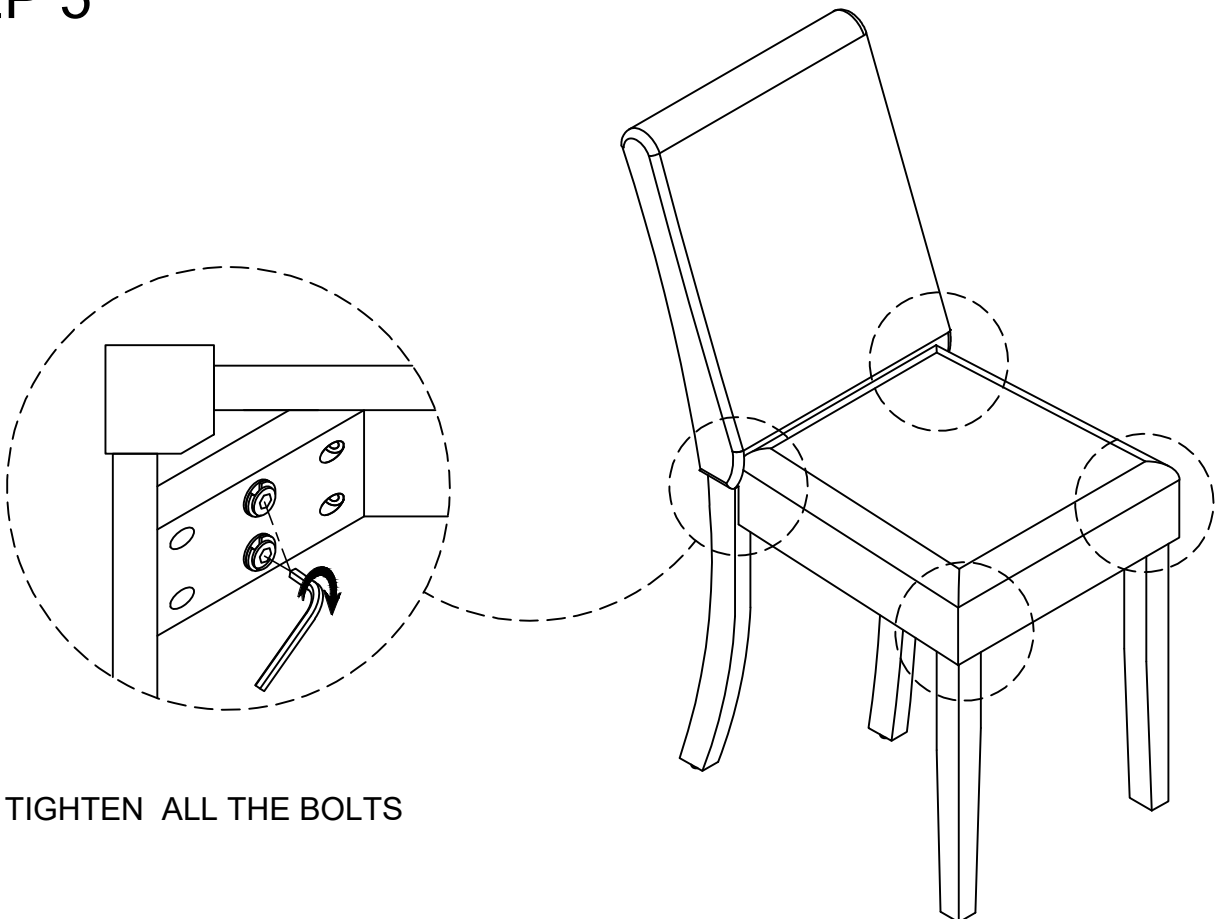

STEP 6

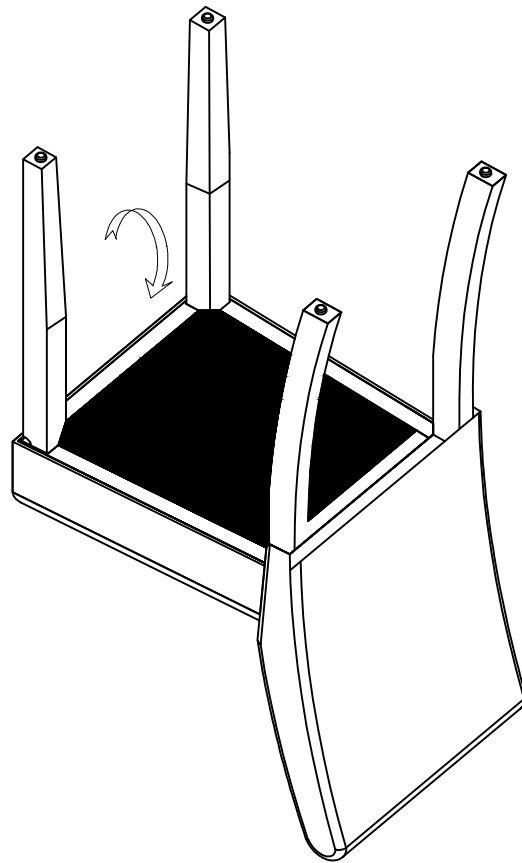

STEP 7

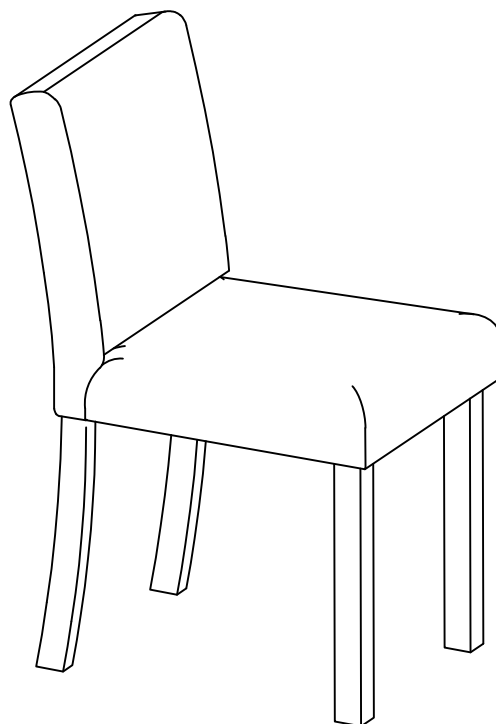

COMPLETED