

ASSEMBLY INSTRUCTIONS

ITEM NO. FB6020HS

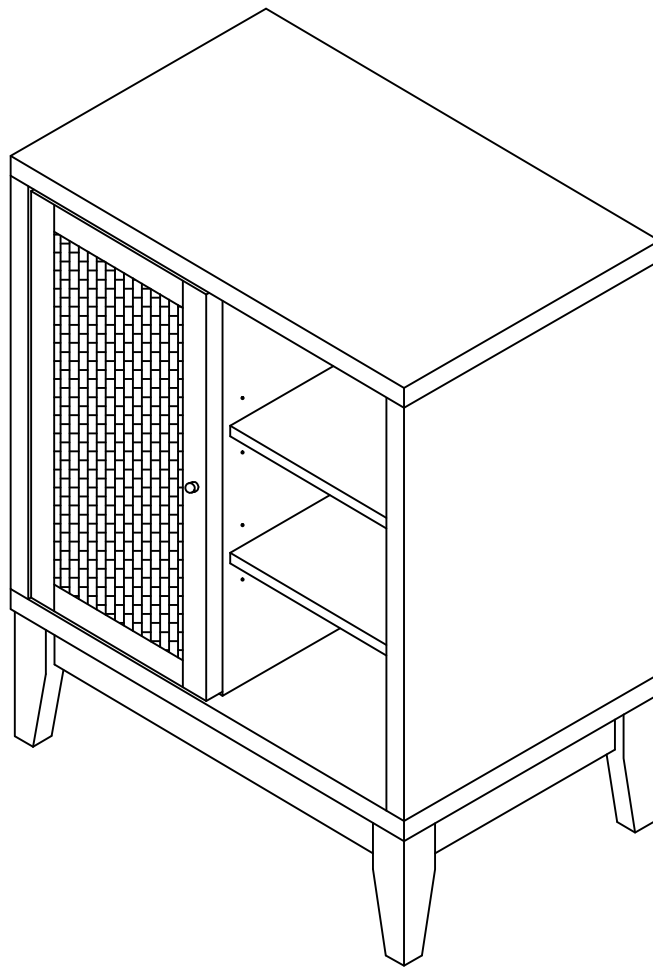



ASSEMBLY TIPS:

1. Remove hardware from box and sort by size.
2. Please check to see that all hardware and parts are present prior to start of assembly.
3. Please follow attached instructions in the same sequence as numbered to assure fast & easy assembly.

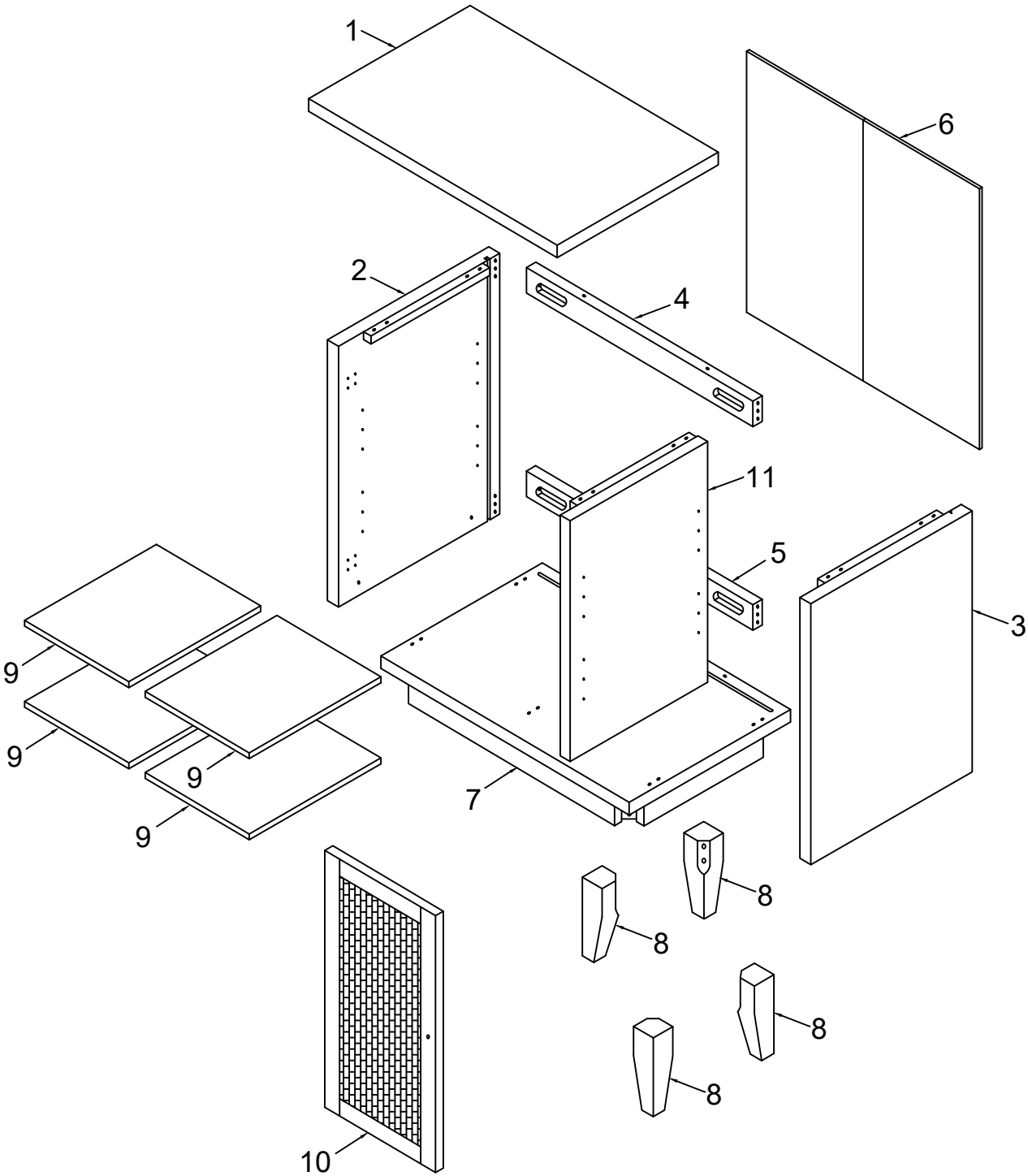



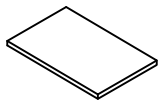
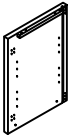
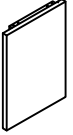
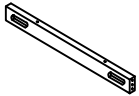
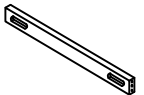
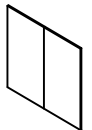
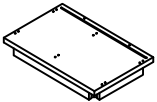

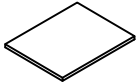
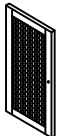
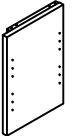









Exploded View



PARTS LIST

NO.	DIAGRAM	PART NAME	Q'Ty
1		Top Panel	1pc
2		Side Frame (Left)	1pc
3		Side Frame (Right)	1pc
4		Top Stretcher	1pc
5		Bottom Stretcher	1pc
6		Back Panel	1pc
7		Bottom Frame	1pc
8		Leg	4pcs
9		Shelf	4pcs
10		Door	1pc
11		Middle partition	1pc

HARDWARE LIST

NO.	DIAGRAM	PART NAME	Q'Ty
A		Bolt Ø1/4" x 1-3/16"	8pcs
B		Bolt Ø1/4" x 2-3/16"	18pcs
C		Bolt Ø1/4" x 2-3/4"	2pcs
D		Lock washer Ø1/4"	24pcs
E		Washer Ø1/4" x 13mm	16pcs
F		Washer Ø1/4" x 19mm	8pcs
G		Crescent pad	4pcs
H		Barrel Nuts Ø1/4" x 12mm	6pcs
I		Allen Key 4mm	1pc
J		Wood Dowel Ø8 x 20mm	20pcs
K		Handle	1pc
L		Bolt Ø5/32" x 7/8"	1pc
M		Hinge	2pcs
N		Screw M3.5 x 15mm	12pcs
O		Shelf pin	16pcs
P		Screw M3 x 12mm	16pcs
Q		Anti-tip Skit	1set

STEP 1

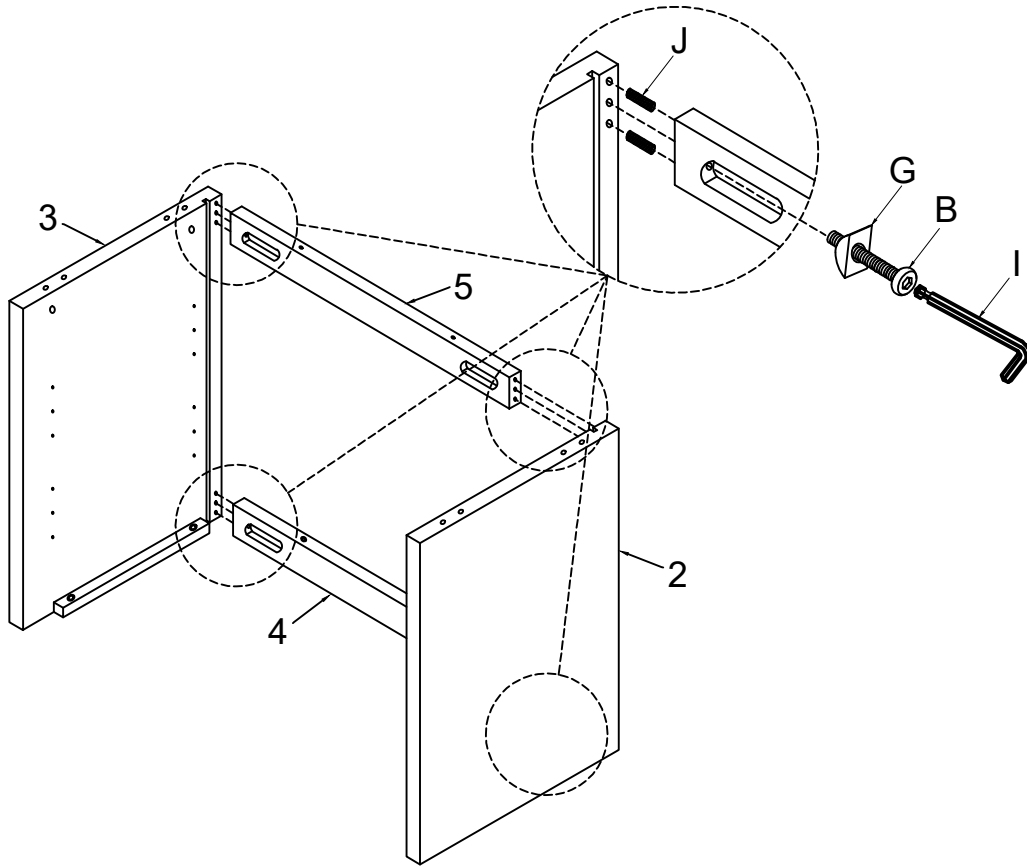

STEP 2

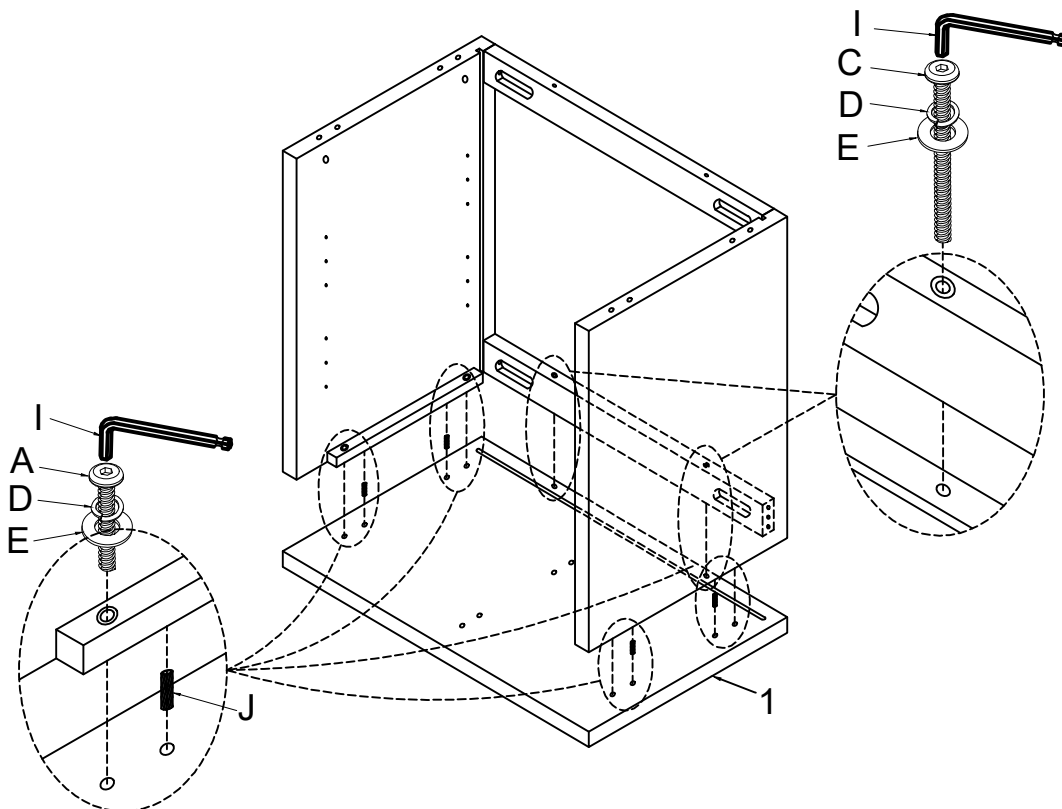

STEP 3

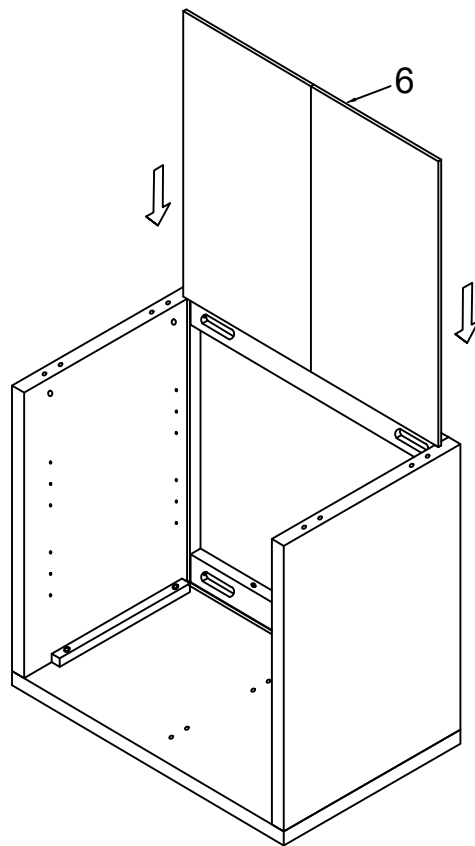

STEP 4

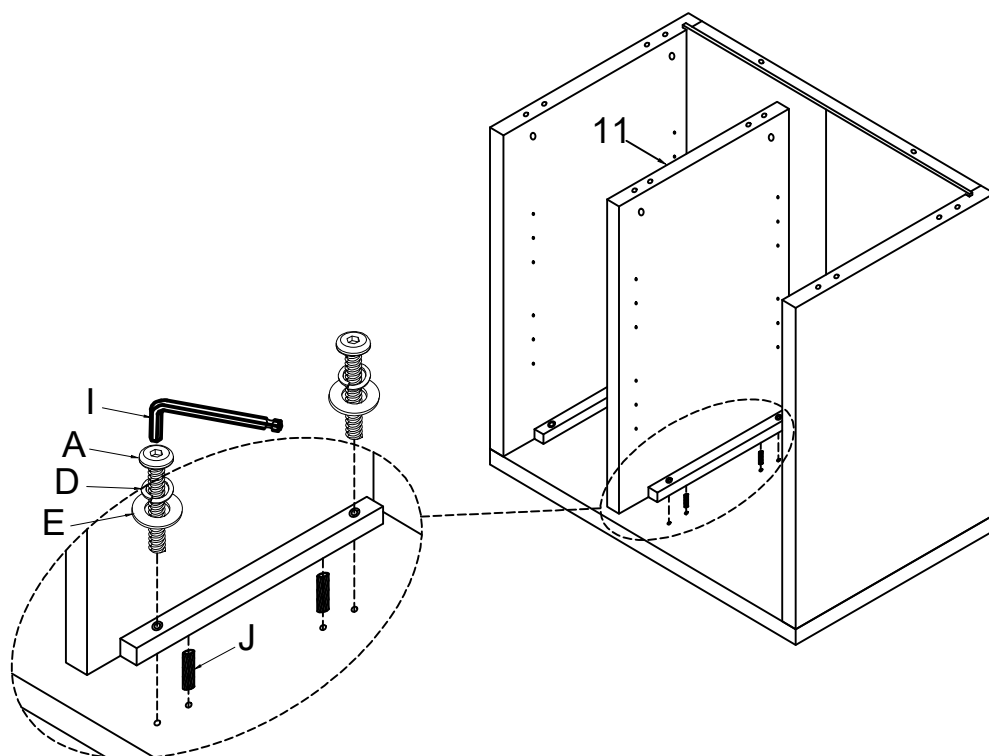

STEP 5

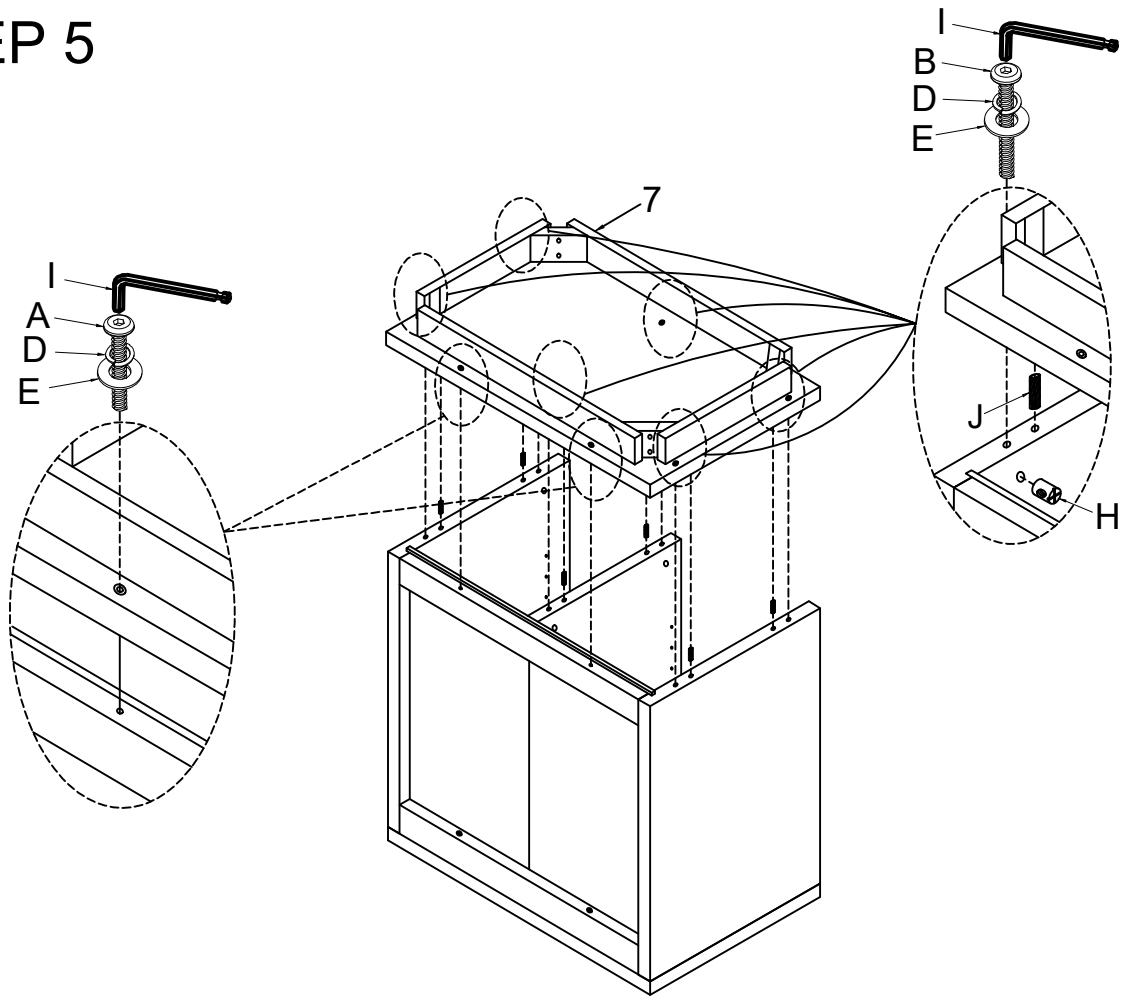

STEP 6

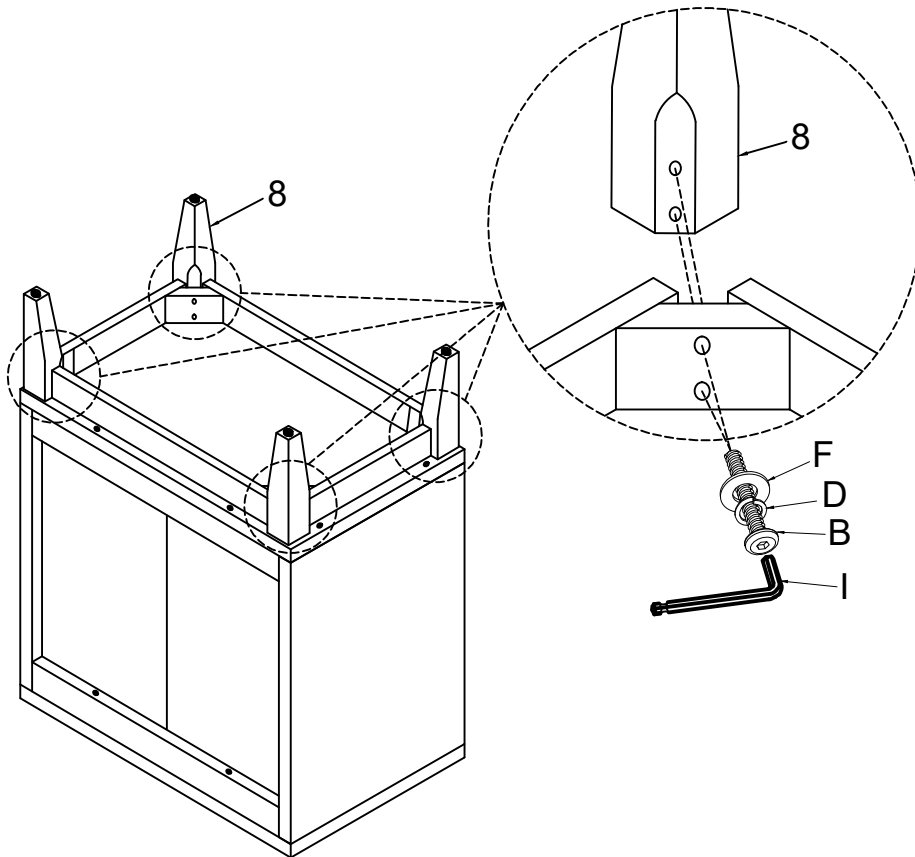

STEP 7

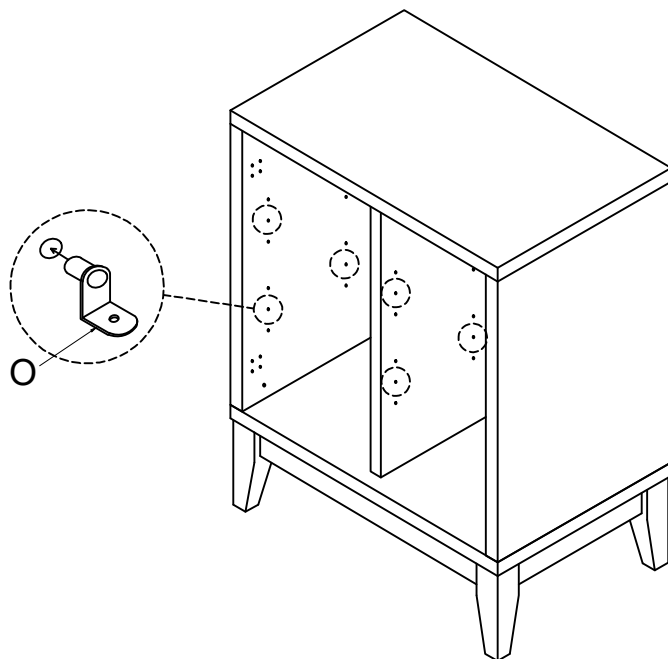

STEP 8

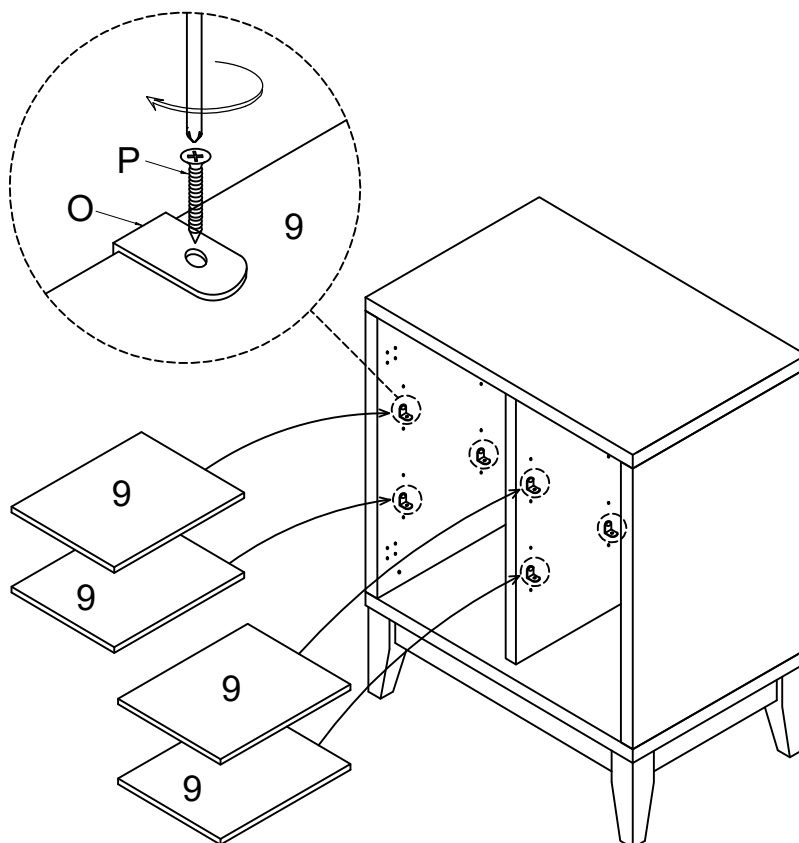

STEP 9

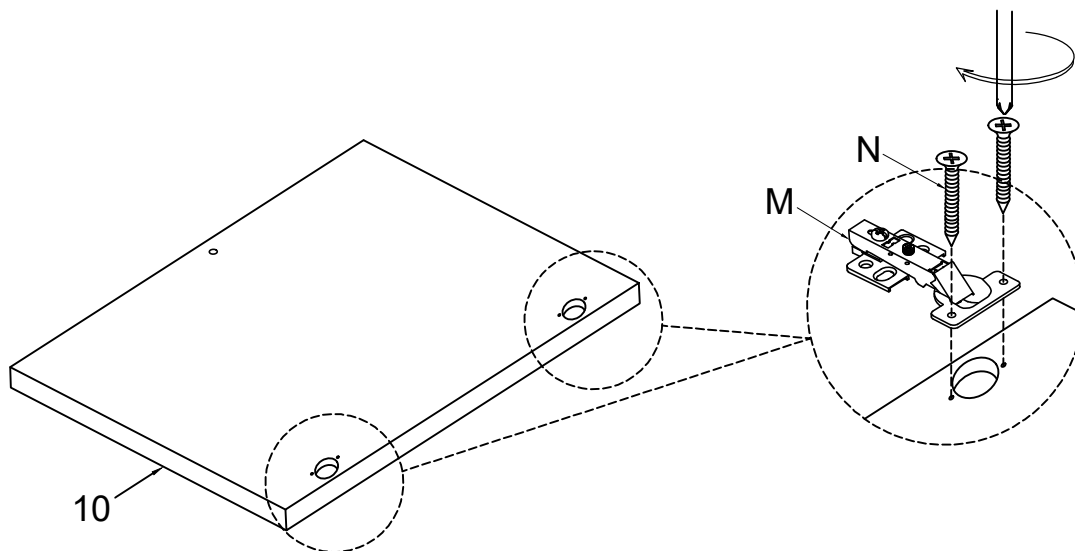

STEP 10

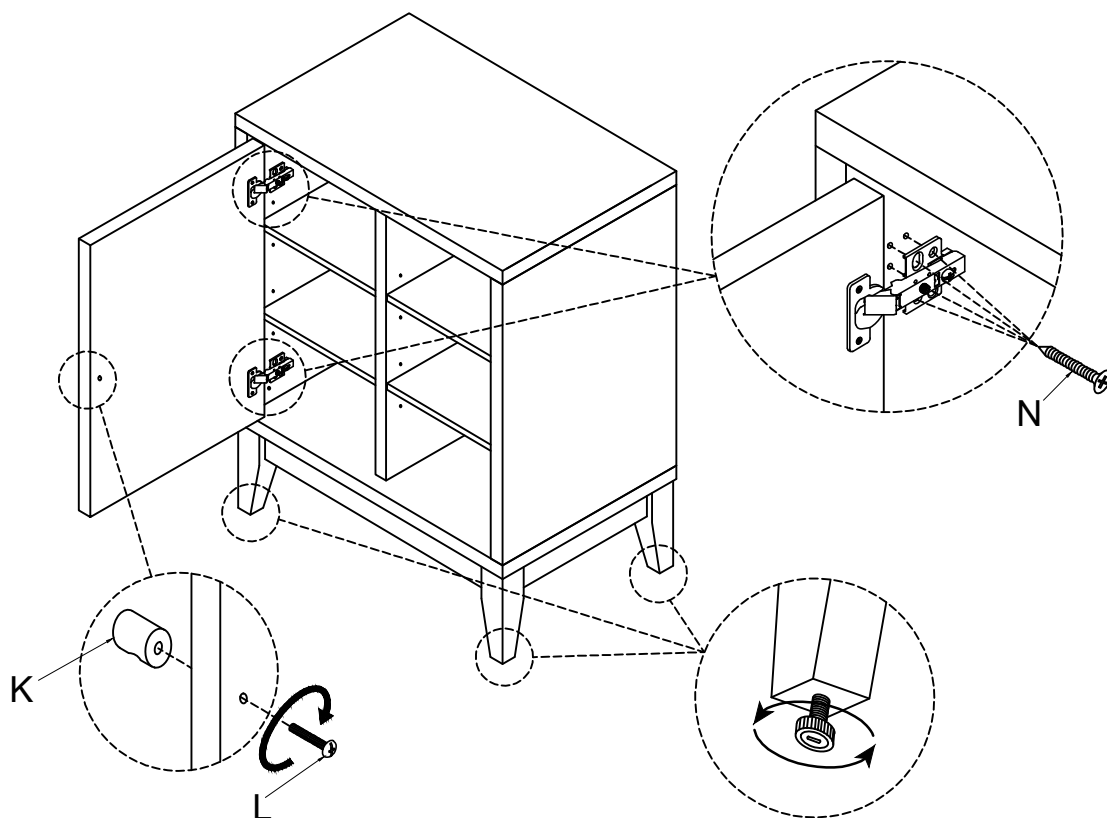

STEP 11

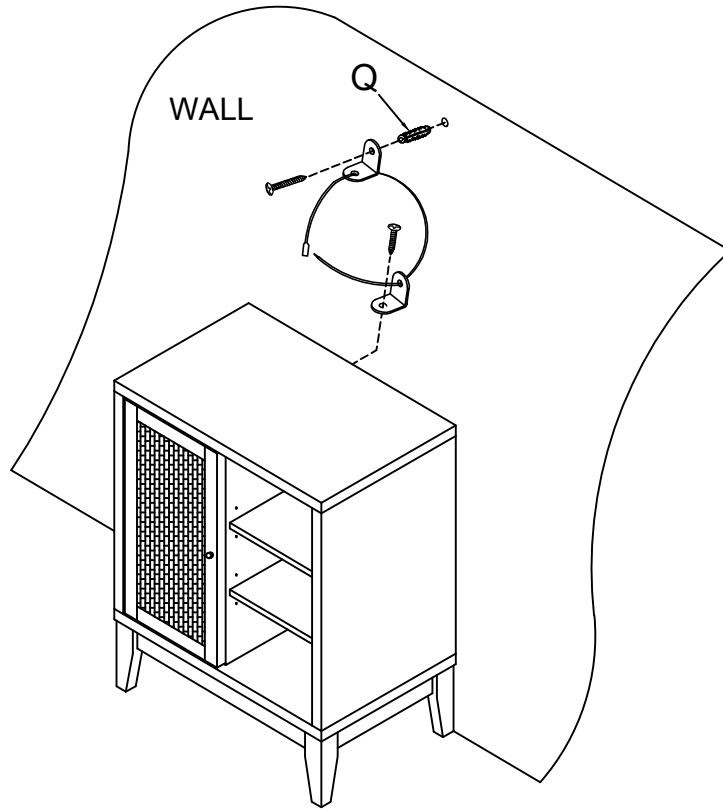

STEP 12

