

ASSEMBLY INSTRUCTION

WF321689



ATTENTION:

1. Check to ensure all parts and hardware are present.
2. We have provided Extra Hardware of B/C/D in case of any bolts missing in the boxes.
3. Do not fully tighten all bolts until all parts are in place. Failure to follow these instructions may cause the bolt to misalign during assembly.

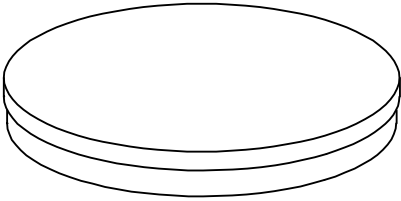
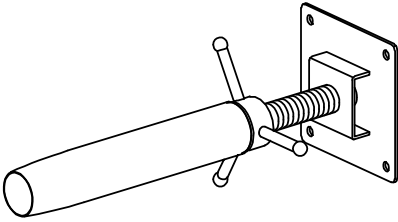
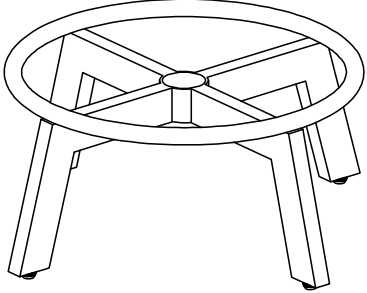
Part List



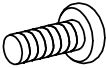

		
① x1PC	② x1PC	③ x1PC

Hardware

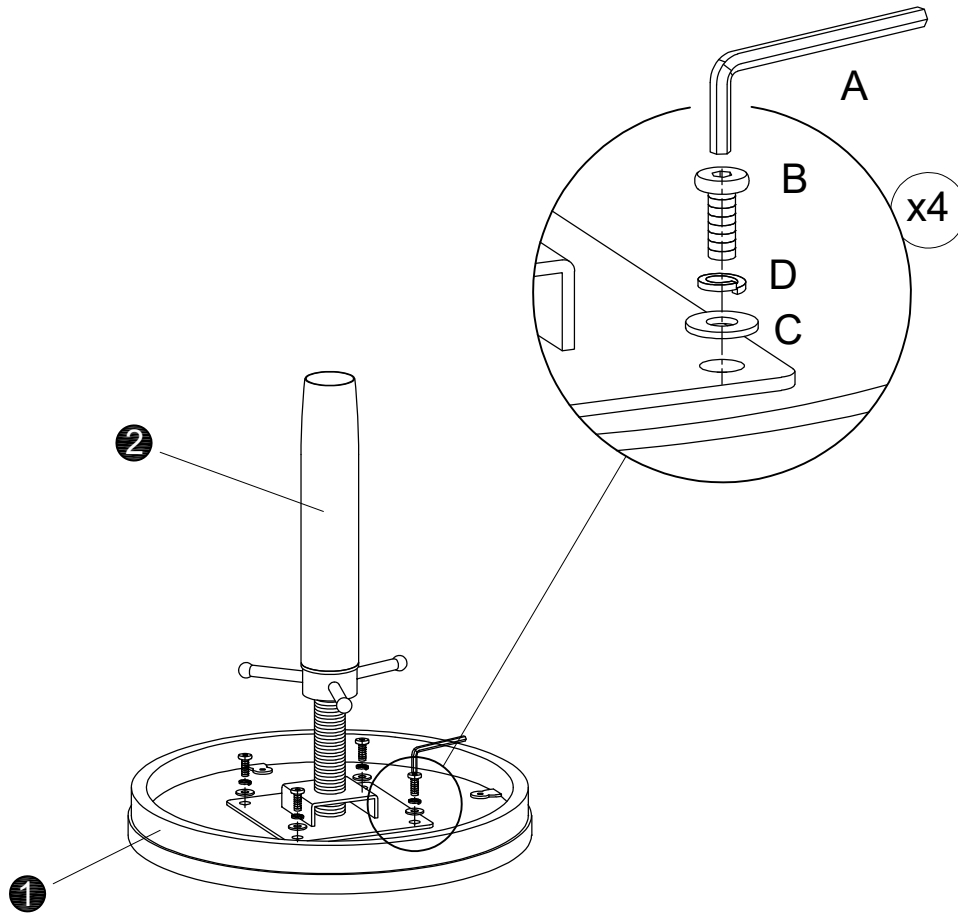
			
M4 A x1PC	φ1/4"x3/4" B x4PCS	C x4PCS	D x4PCS

Step 1



A		1PC
B		4PCS
C		4PCS
D		4PCS

Step 2

