



ASSEMBLY INSTRUCTION

WF321688





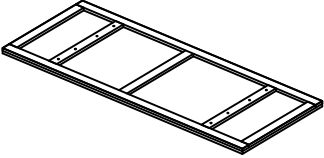
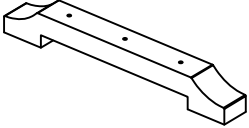
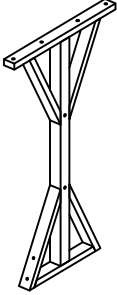
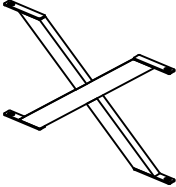
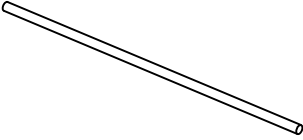

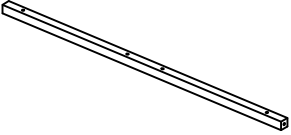
ATTENTION:

1. Check to ensure all parts and hardware are present.
2. We have provided Extra Hardware of B/C/D/E/F/G in case of any bolts missing in the boxes.
3. Do not fully tighten all bolts until all parts are in place. Failure to follow these instructions may cause the bolt to misalign during assembly.

Part List

			
① x1PC	② x2PCS	③ x2PCS	④ x2PCS
			
⑤ x2PCS	⑥ x4PCS	⑦ x2PCS	

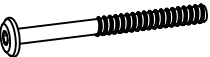
Hardware

			
M4 A x1PC	M6*12mm B x20PCS	M6*30mm C x8PCS	M6*45mm D x6PCS
			
M6*60mm E x4PCS	F x6PCS	G x6PCS	

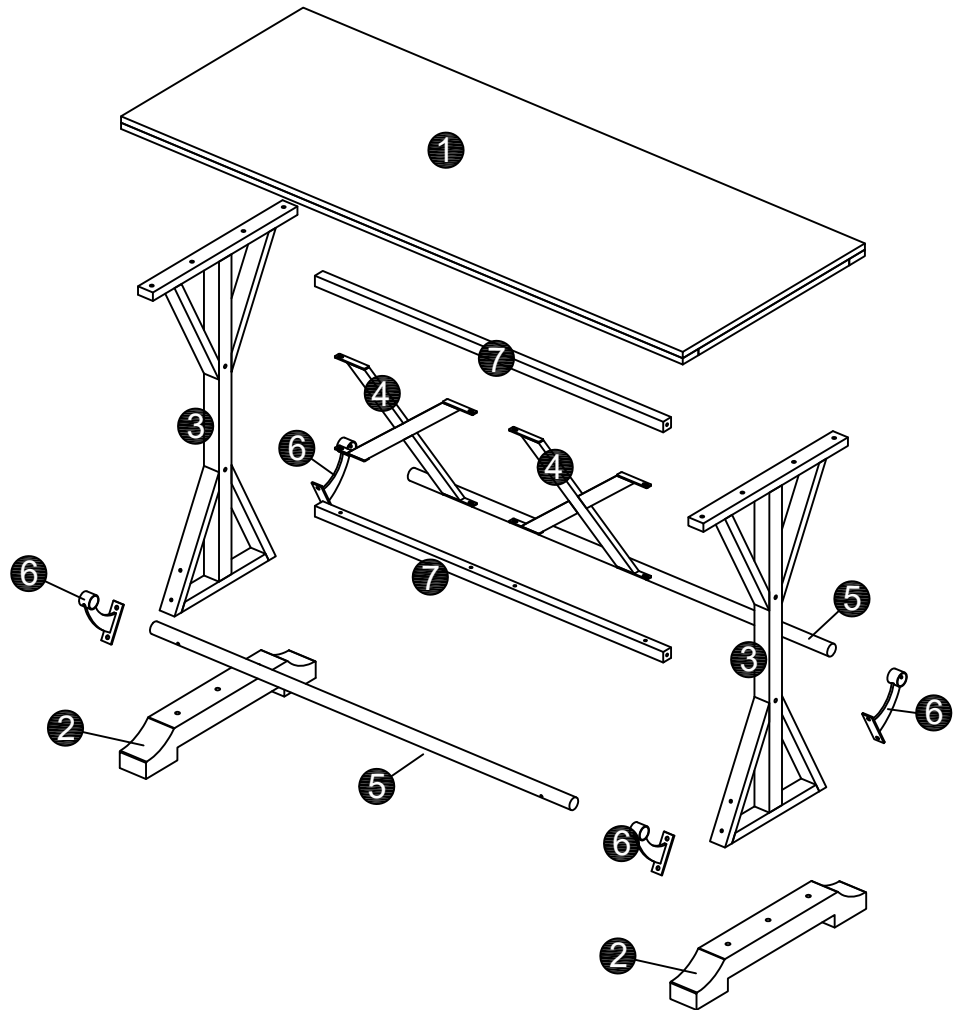
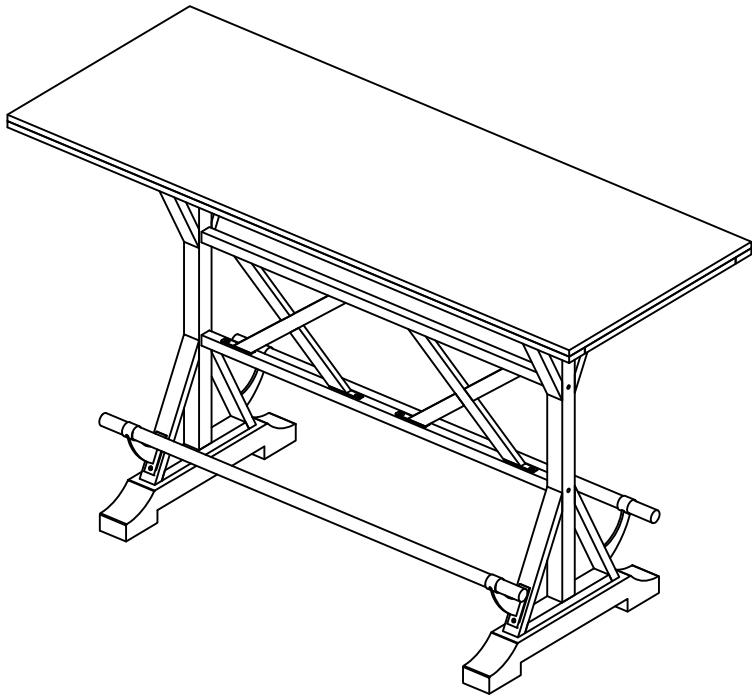

Step 1

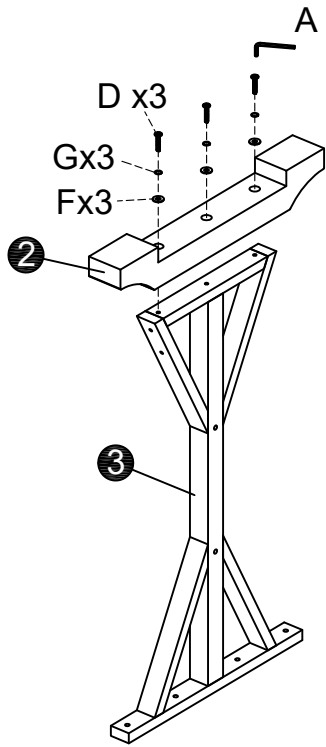

X 2

A		1PC
D		6PCS
F		6PCS
G		6PCS

Step 2

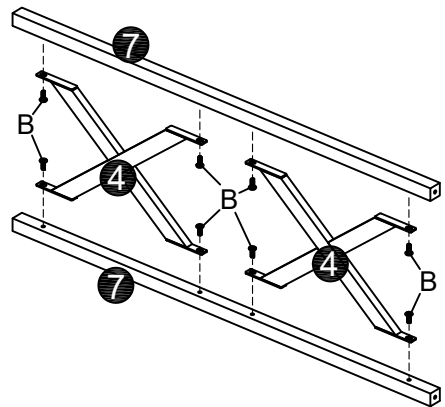

A		1PC
B		8PCS

Step 3

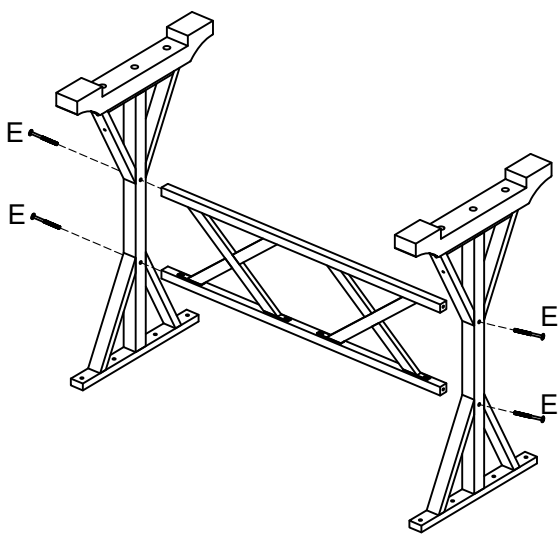

A		1PC
E		4PCS

Step 4

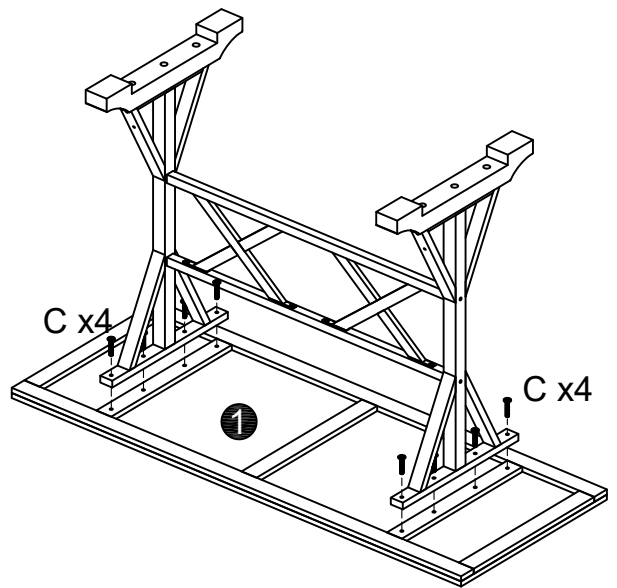

A		1PC
C		8PCS

Step 5

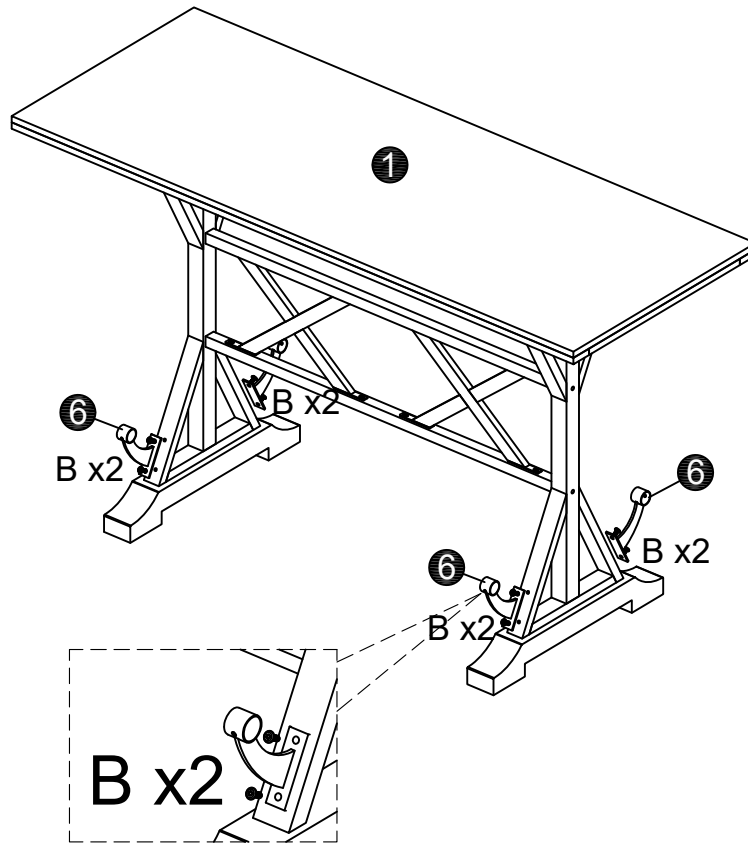

A		1PC
B		8PCS

Step 6

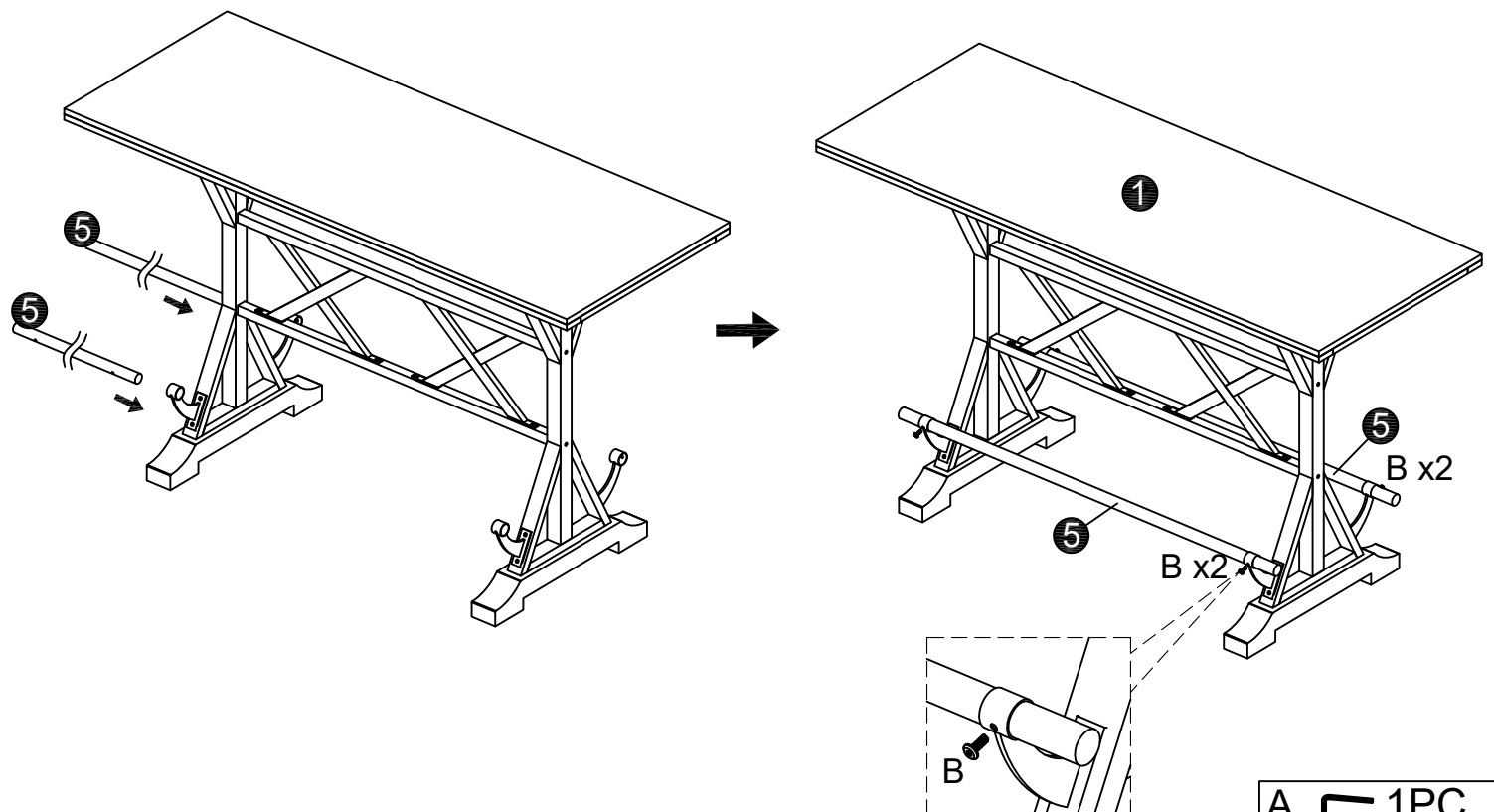

A		1PC
B		4PCS