





ASSEMBLY INSTRUCTION

WF321687



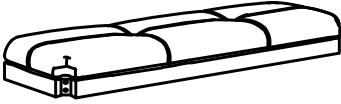



ATTENTION:

1. Check to ensure all parts and hardware are present.
2. We have provided Extra Hardware of A/B/C/E/F in case of any bolts missing in the boxes.
3. Do not fully tighten all bolts until all parts are in place. Failure to follow these instructions may cause the bolt to misalign during assembly.

Part List

		
<p>① x1PC</p>	<p>②x1PC</p>	<p>③x2PCS</p>
		
<p>④ x2PCS</p>	<p>⑤x2PCS</p>	

Hardware

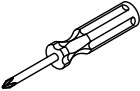
 <p>5/16 x63mm</p>	 <p>M8</p>	 <p>8*22*1.5</p>	 <p>M5</p>
<p>A x8PCS</p>	<p>B x8PCS</p>	<p>C x8PCS</p>	<p>D x1PC</p>
 <p>8*40mm</p>	 <p>8*25mm</p>		
<p>E x4PCS</p>	<p>F x2PCS</p>	<p>G x1PC</p>	

Step 1

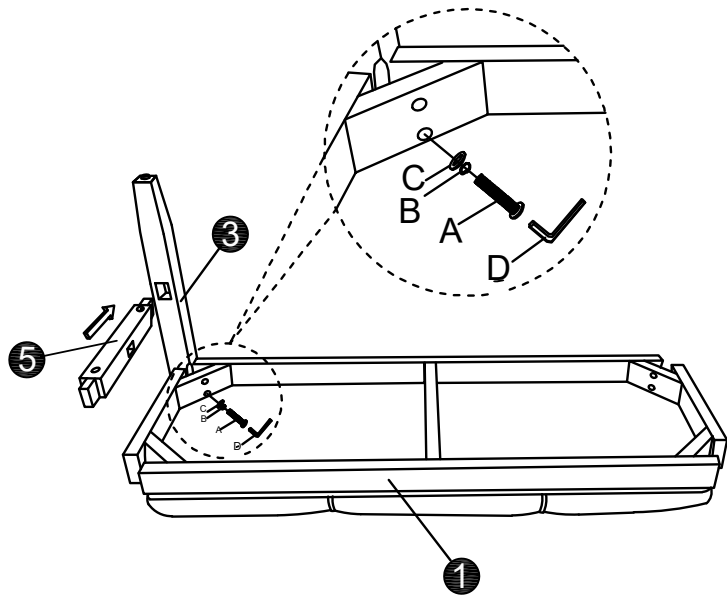

A		4PCS
B		4PCS
C		4PCS
D		1PC

Step 2

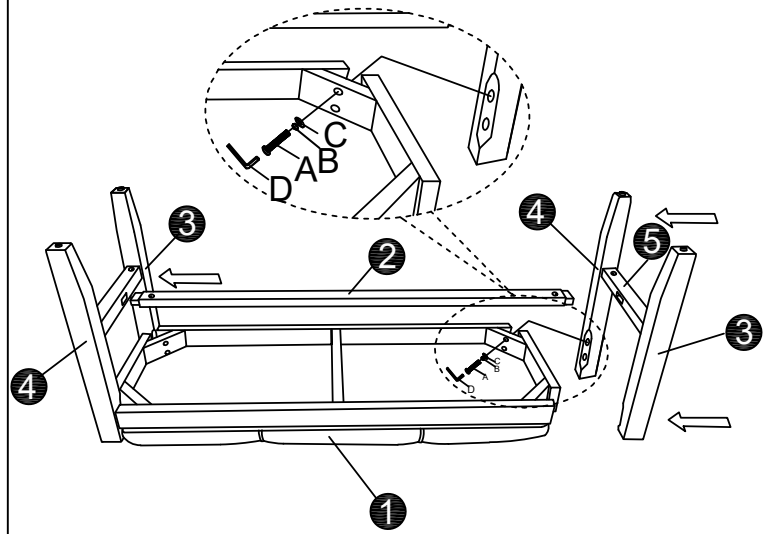

A		4PCS
B		4PCS
C		4PCS
D		1PC

Step 3

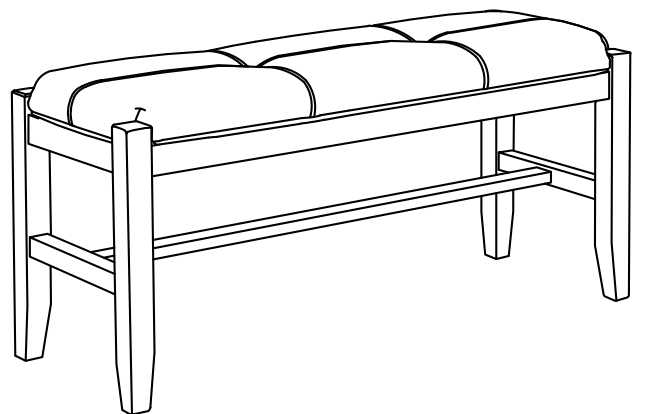
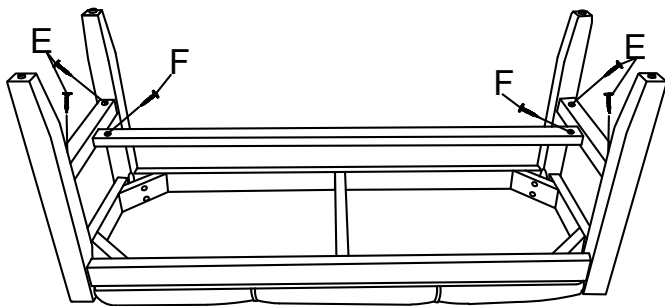

G		1PC
E		4PCS
F		2PCS