

ASSEMBLY INSTRUCTIONS

SKU NO. : WF318393
DESCRIPTION : CHAIR

IMPORTANT NOTE

****PLACE ALL PARTS ON A CLEAN AND SMOOTH SURFACE SUCH AS A RUG OR CARPET TO AVOID THE PARTS FROM BEING SCRATCHED**

****BEFORE YOU BEGIN, KINDLY FOLLOW THE ASSEMBLY INSTRUCTIONS STEP BY STEP**

****DO NOT TIGHTEN ALL SCREWS AND BOLTS UNTIL THE CHAIR IS FULLY SET-UP**

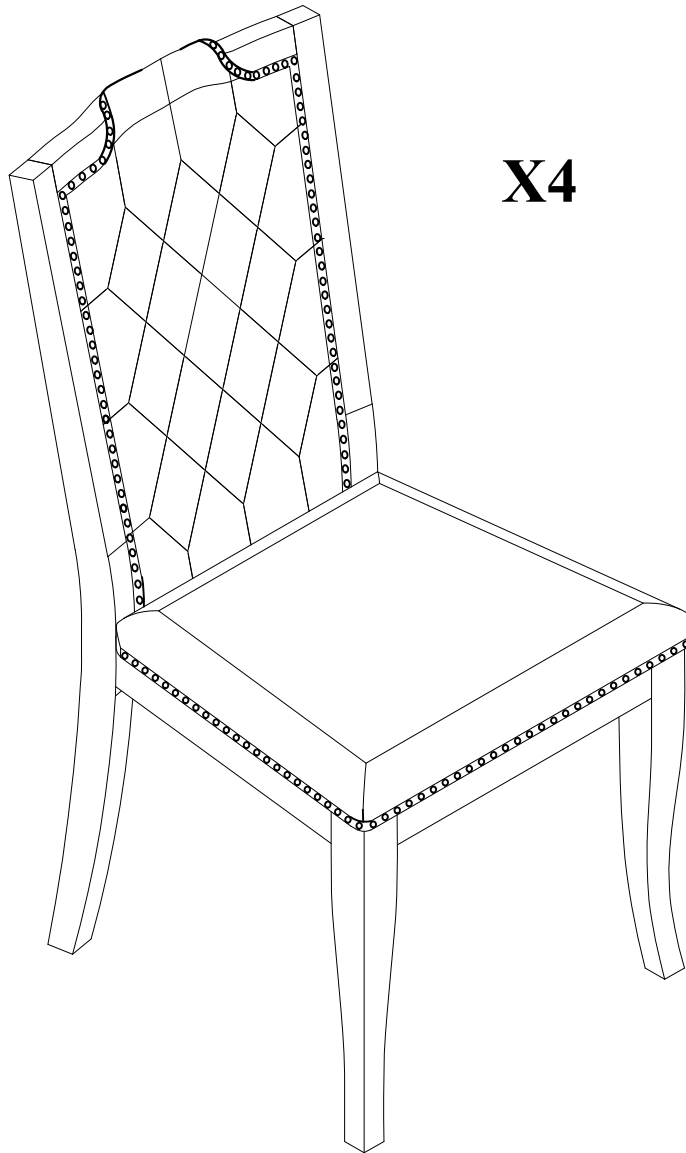





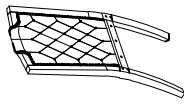

PLEASE DO NOT RETURN PRODUCT TO THE STORE

ASSEMBLY INSTRUCTIONS

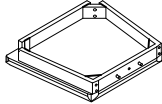
SKU NO. : WF318393
DESCRIPTION : CHAIR

CARTONS ONLY ONE / HARDWARE LIST

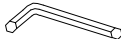
| PART LISTS | | | | HARDWARE LIST | | | |
|------------|--------------|---|-------|---------------|------------------------------|---|--------|
| NO | DESCRIPTION | SKETCH | Q'TY | NO | DESCRIPTION | SKETCH | Q'TY |
| A | CHAIR BACK |  | 4 PCS | 1 | BOLT Ø5/16*75mm |  | 16 PCS |
| | | | | 2 | BOLT Ø5/16*50mm |  | 20 PCS |
| B | SEAT CUSHION |  | 4 PC | 3 | WASHER Ø5/16"*19mm |  | 36 PCS |
| C | LEGS |  | 8 PCS | 4 | SPRING WASHER Ø5/16"*11mm |  | 36PCS |
| | | | | 5 | ALLEN KEY M4*60mm |  | 1 PC |

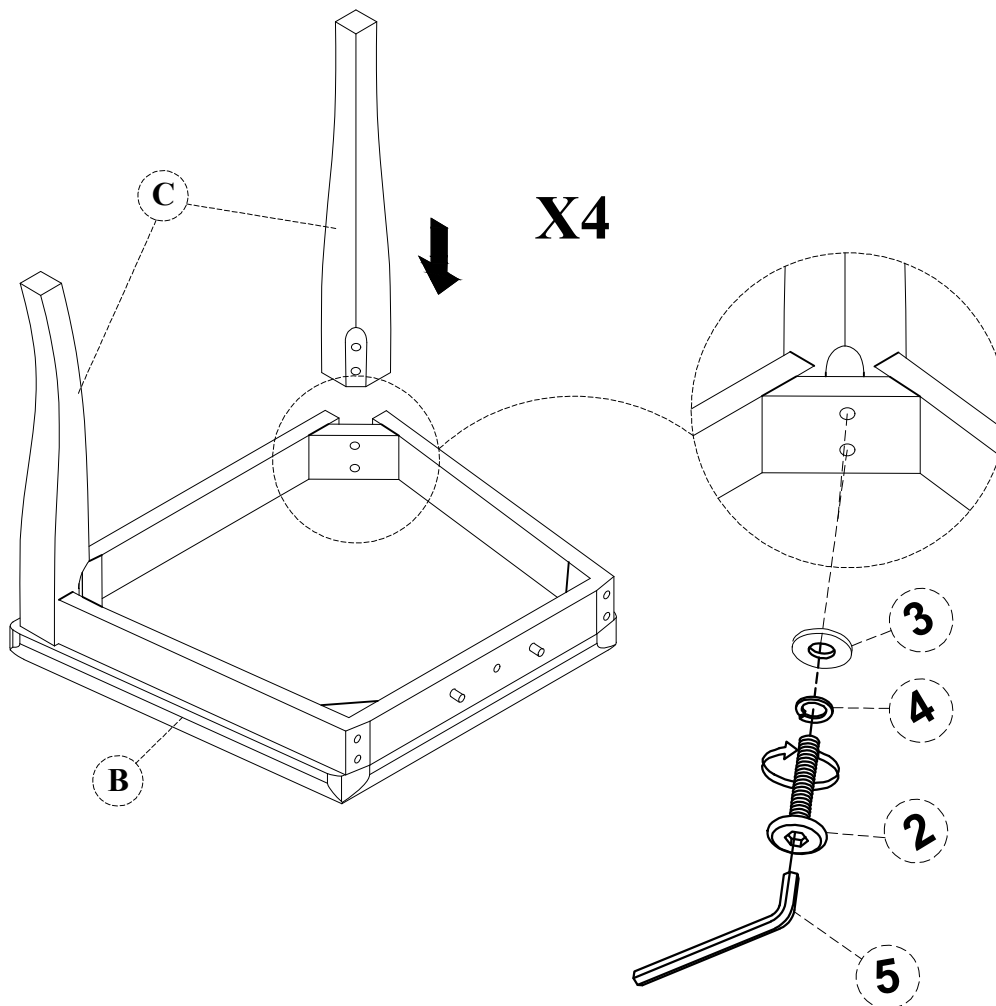

ASSEMBLY INSTRUCTIONS

SKU NO. : WF318393
DESCRIPTION : CHAIR

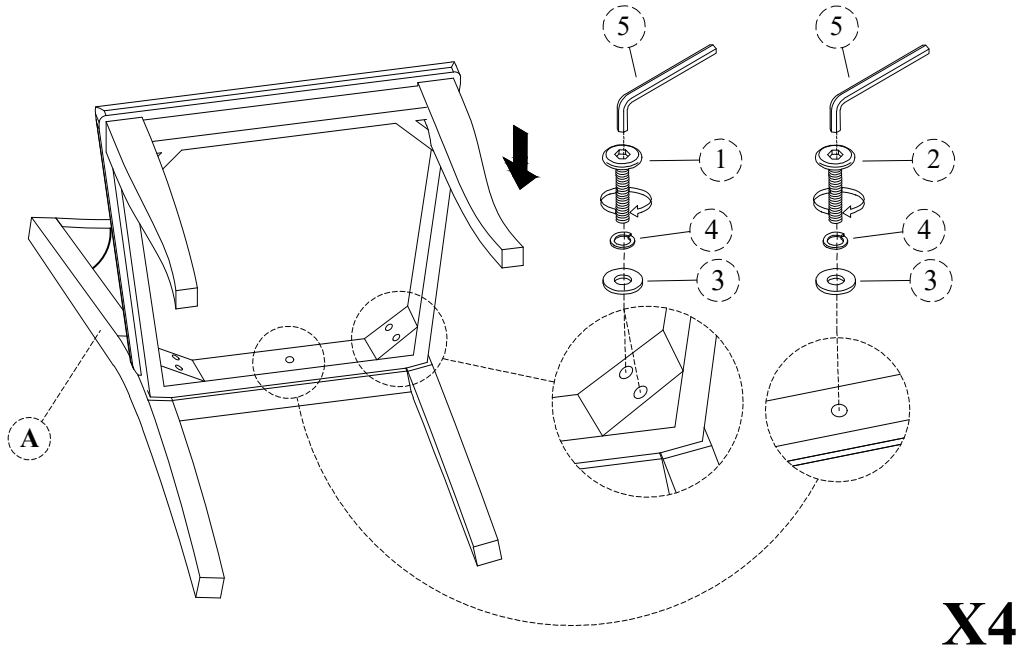

COMPLETE

