











# ASSEMBLY INSTRUCTION

## SKU:WF316052 / WF316053

### PART LIST

ITEM	DESCRIPTION	QTY
1	BACKREST 	1PC
2	SEAT FRAME 	1PC
3	FRONT LEG 	2PCS

### HARDWARE

ITEM	DESCRIPTION	QTY
A	DOWEL 10*30 	1PC
B	5/16*45MM BOLT 	2PCS
C	5/16*57MM BOLT 	4PCS
D	5/16*83MM BOLT 	4PCS
E	M8 SPRING WASHER 	10PCS
F	8*22*1.5MM FLAT WASHER 	10PCS
G	M5 ALLEN KEY 	1PC

#### STEP1:

Stick the dowel(A) in the seat frame(2).

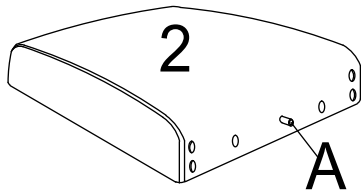

#### STEP2:

Open the velcro strips on the edge of the seat frame, attach the seat frame(2) to the backrest(1), use the allen key(G) to fully fasten 6pcs bolt (B and D), 6pcs flat washer(E) and 6pcs spring washer(F).

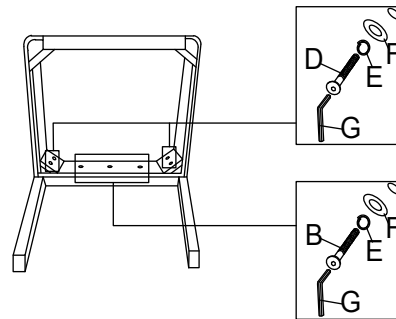

#### STEP3:

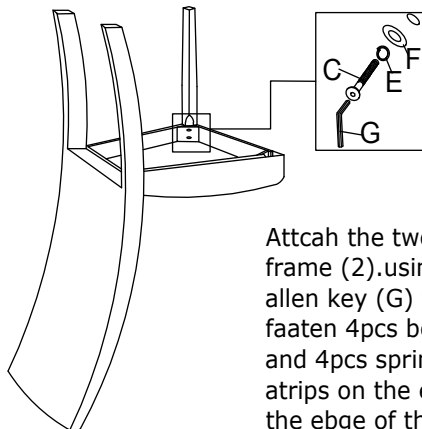

Attach the two front leg(3) to the seat frame (2) using the allen key (G) to fully fasten 4pcs bolt(C), 4pcs flat washer (E) and 4pcs spring washer(F). stick velcro strips on the edge of non woven to it on the edge of the seat frame.

