

ASSEMBLY INSTRUCTIONS

Bench

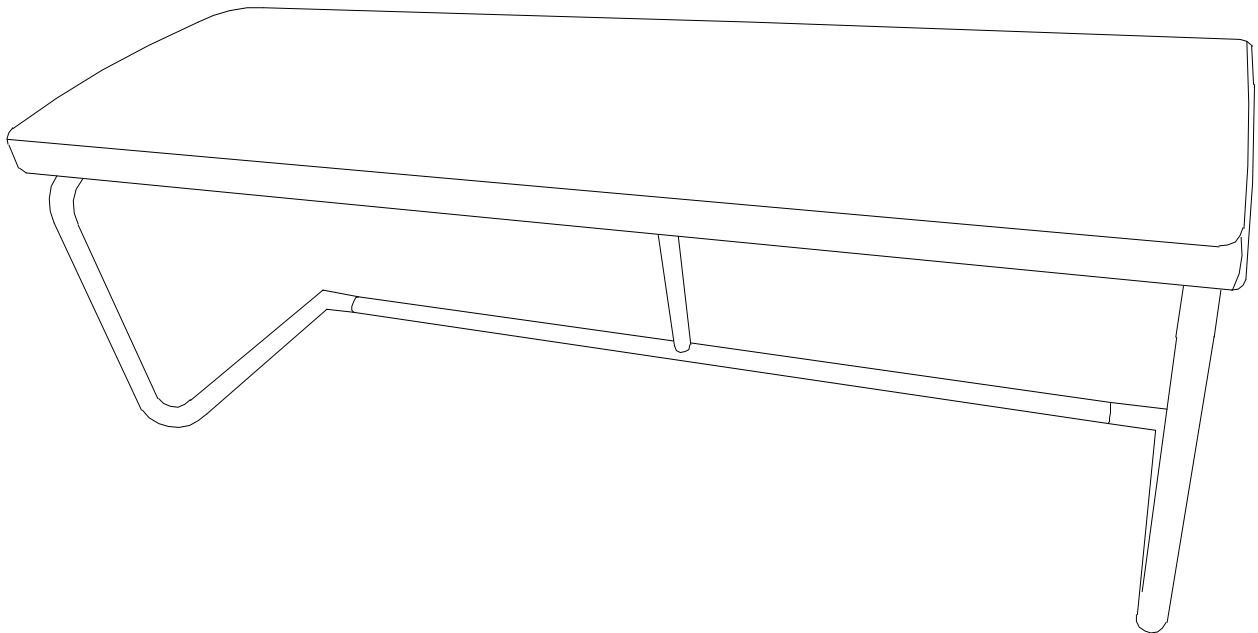

WF312282

IMPORTANT NOTE:

1. Place all parts on a clean and smooth surface such as a rug or carpet to avoid the parts from being scratched.
2. Before you begin, kindly follow the assembly instructions step by step.
3. Do not tighten all screws and bolts until the bench is fully set-up.
4. Please do not return to store, contact the seller if you have any troubles with this product.

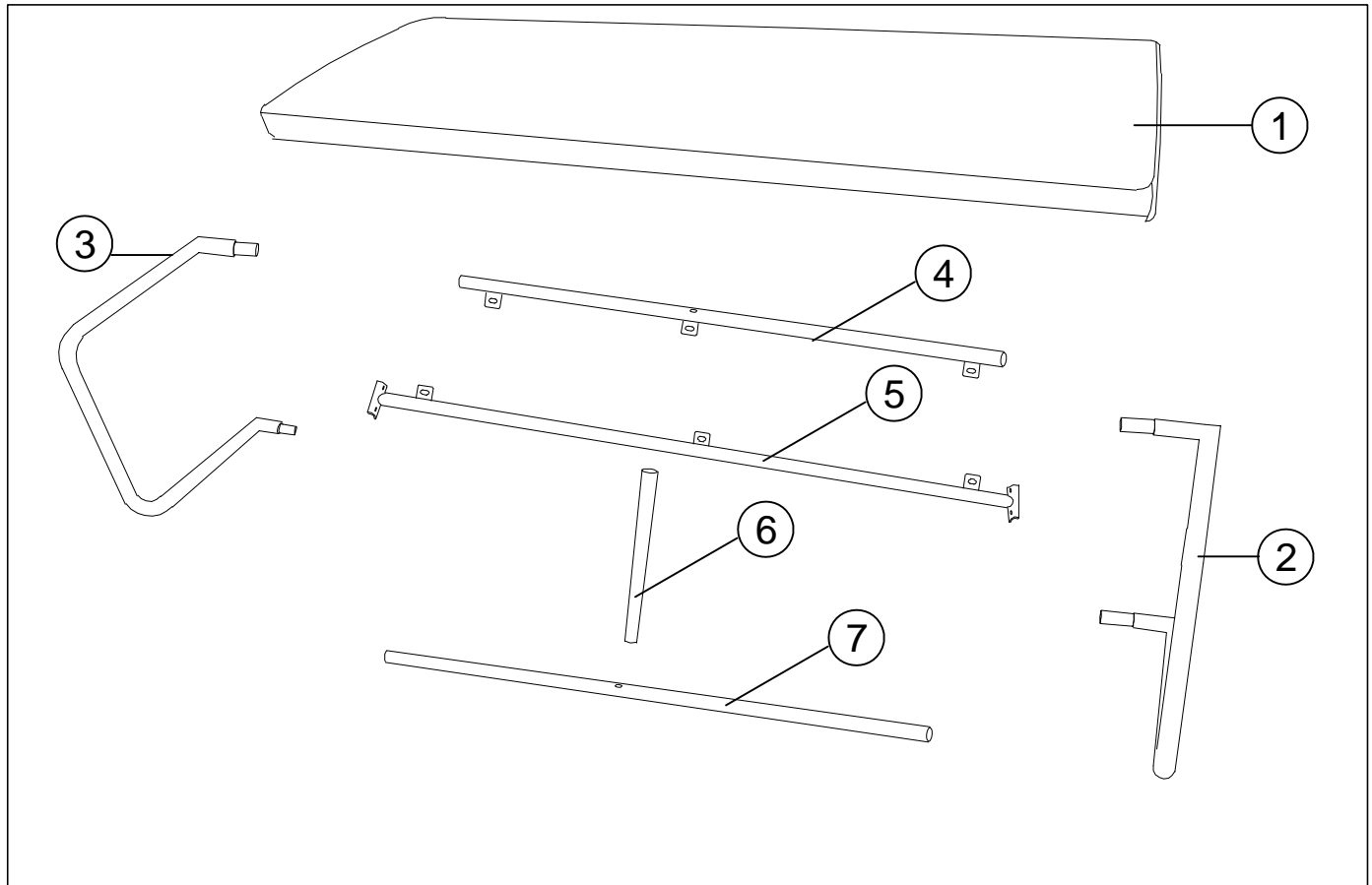

Part List





① x1	② x1	③ x1	④ x1	⑤ x1	⑥ x1	⑦ x1

Hardware List

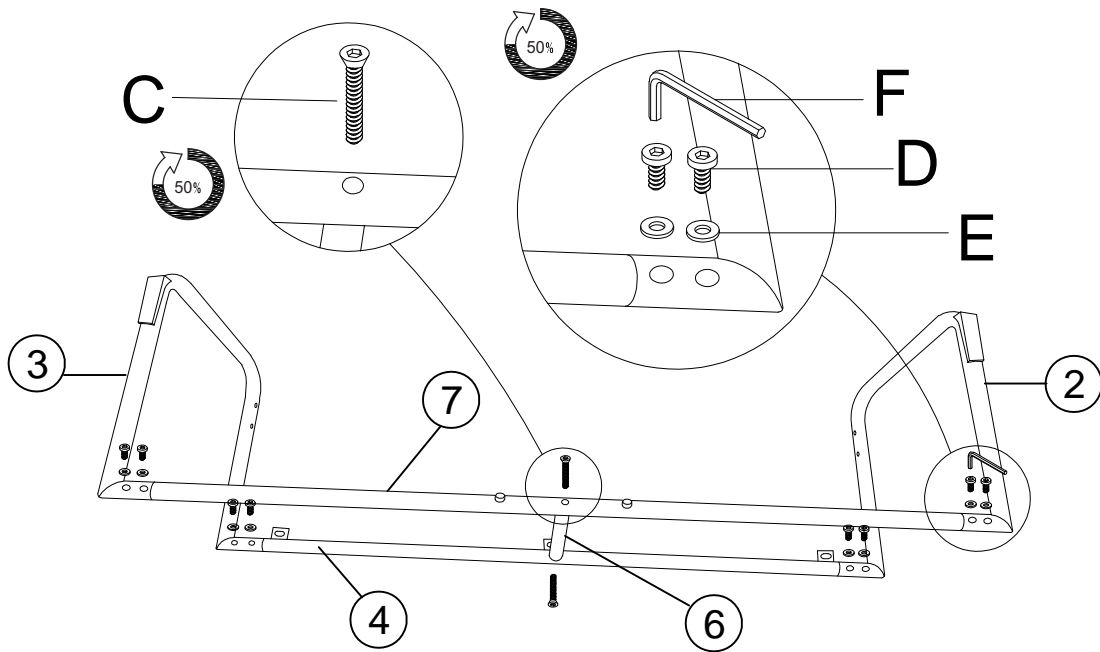
A M6x16 BOLT (6pcs)	D M6x13 BOLT (12pcs)
B 6x16 LOCK WASHER (6pcs)	E 6x14 LOCK WASHER (12pcs)
C M6x40 BOLT (2pcs)	F M4 ALLEN KEY (1pc)



Step 1



C		2pcs	E		8pcs
D		8pcs	F		1pc

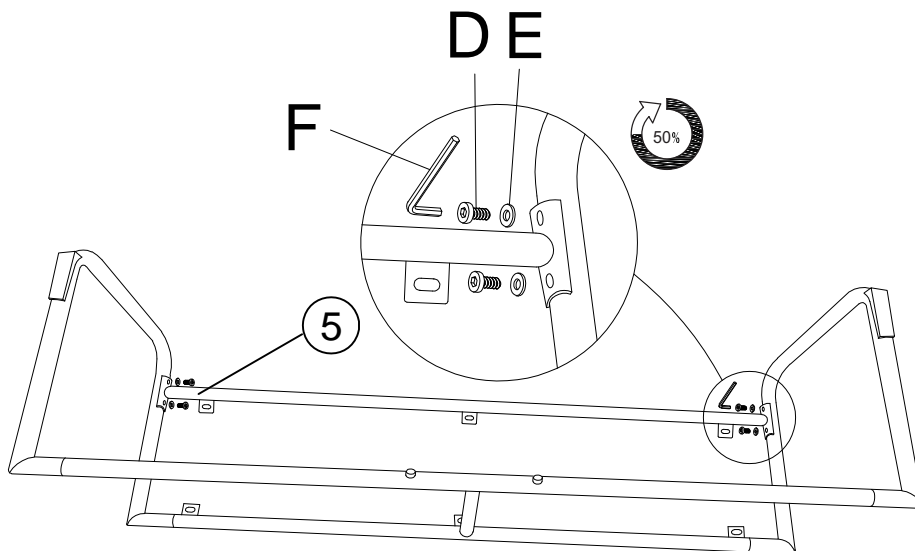

Step 2

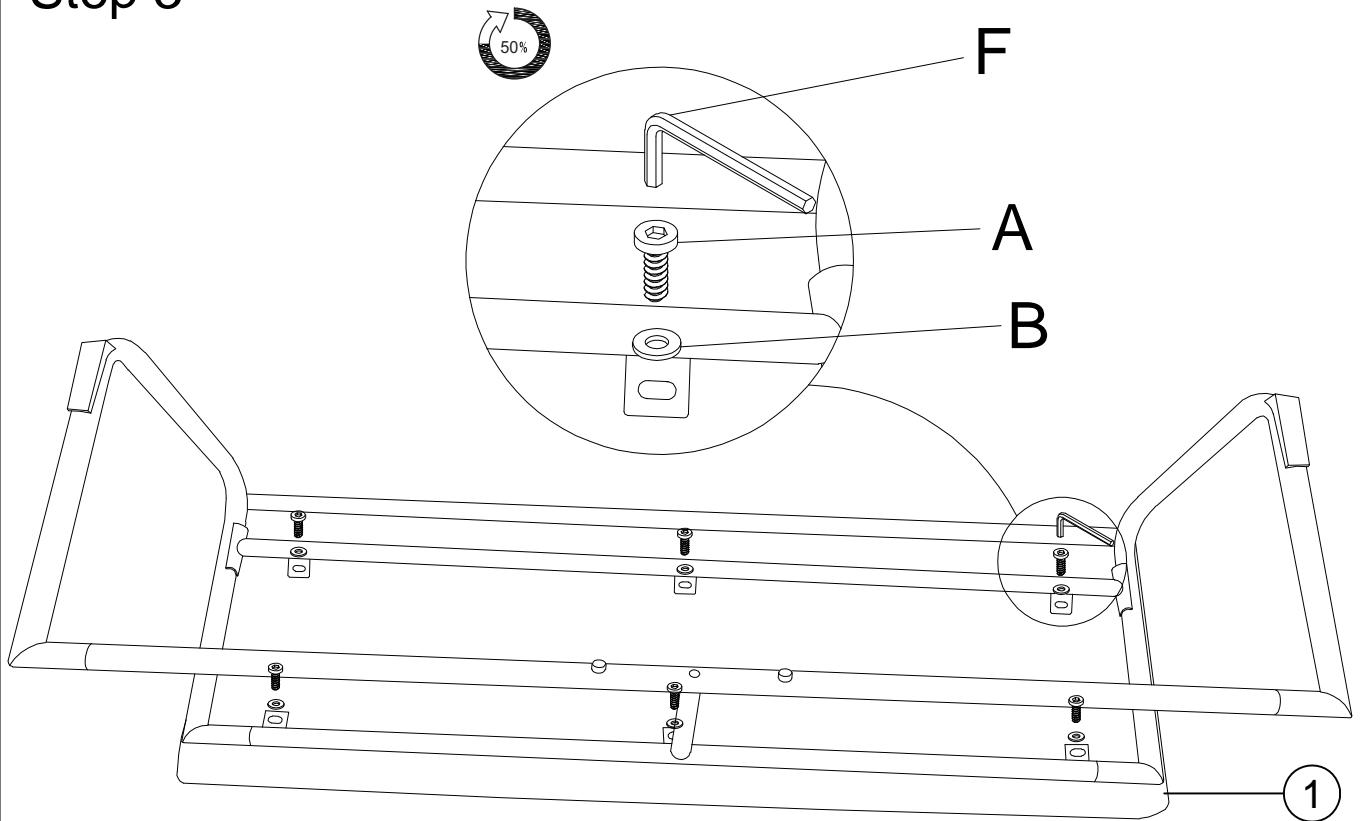

D		4pcs	F		1pc
E		4pcs			

Step 3



A		6pcs	F		1pc
B		6pcs			

Step 4

