

ASSEMBLY INSTRUCTION

(WF313718/WF313719/WF313721/WF313722)

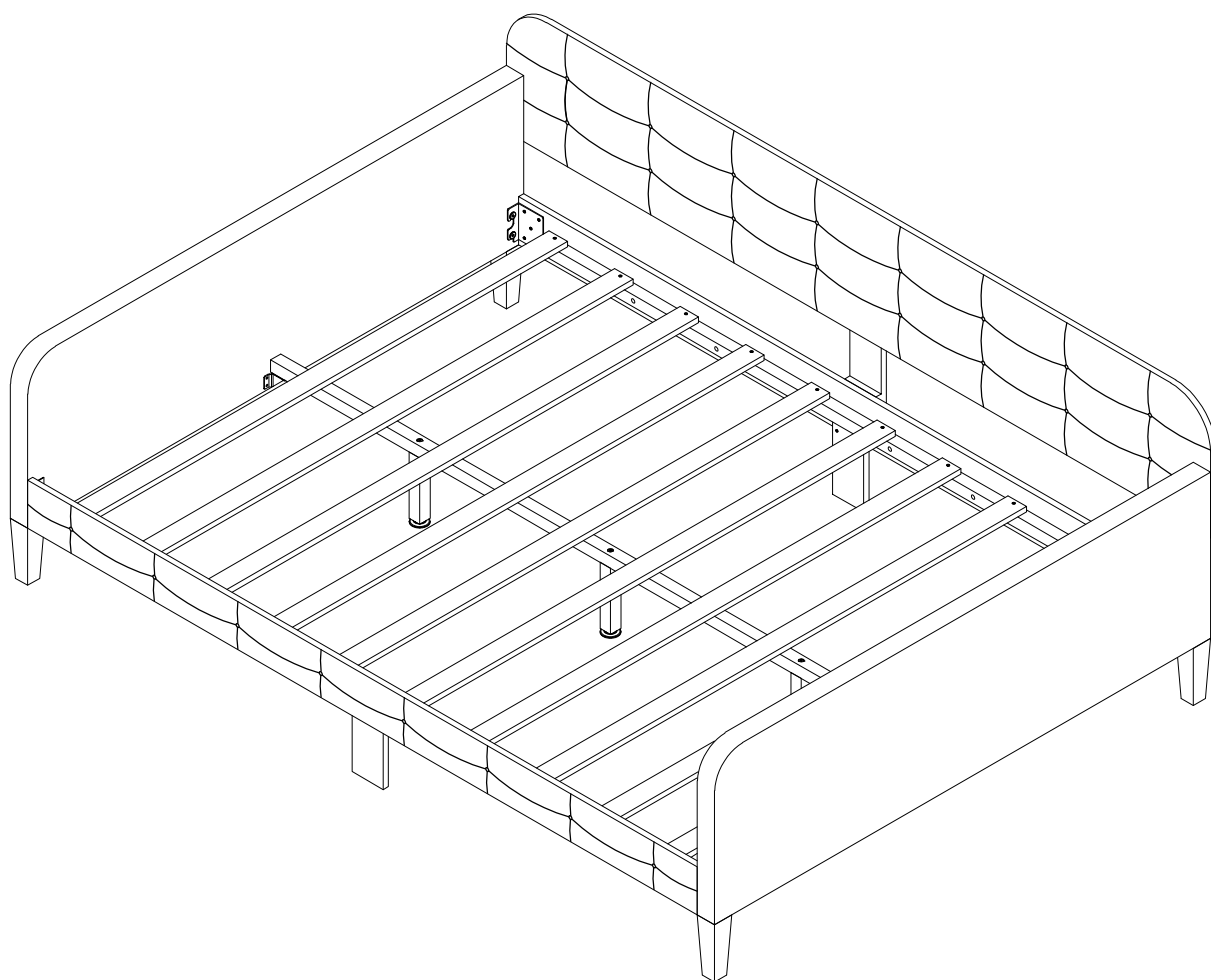

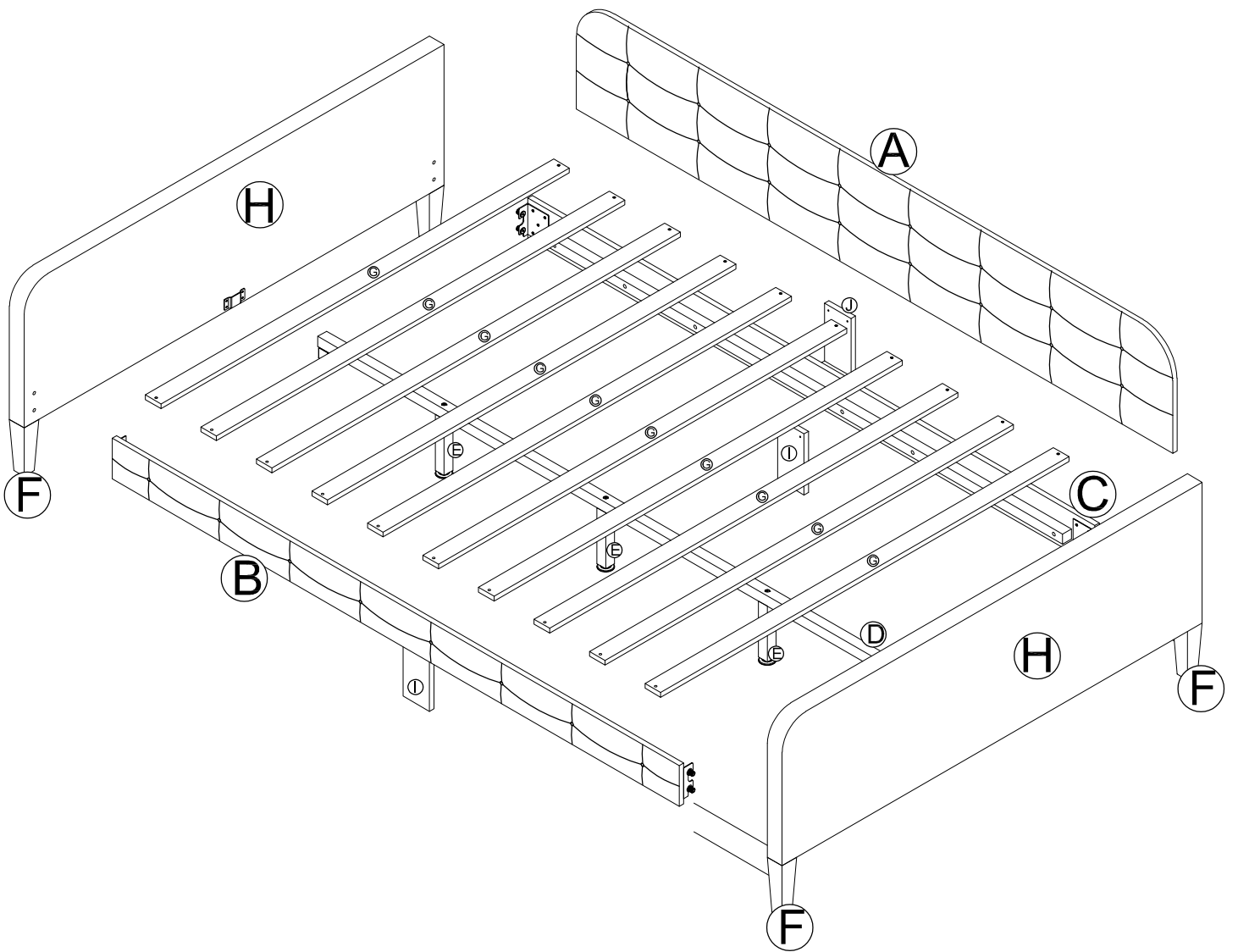

Part List (Box 1-WF313718/WF313721)

A

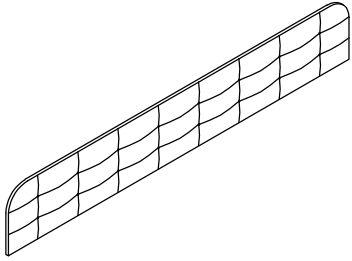

HEADBOARD - 1pc

B

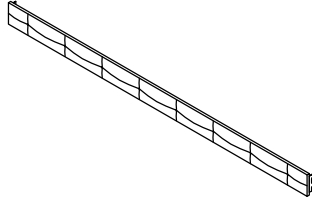

SIDE PANEL OUTSIDE - 1pc

C

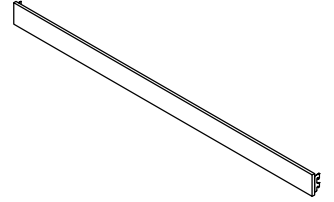

SIDE PANEL INSIDE - 1pc

D

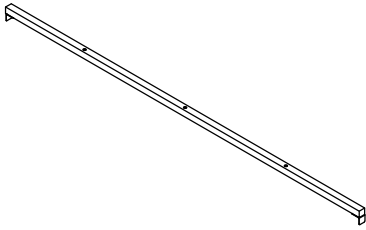

CENTER WOOD BASE - 1pc

E



WOODEN SUPPORT LEG - 3pcs

F

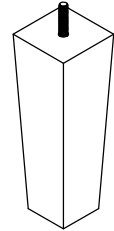

WOODEN LEG - 4pcs

G

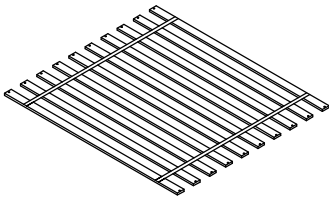

SLAT - 1SET/10pcs

I



BOTTOM SUPPORT - 2pcs

J

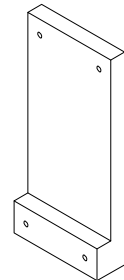

HEADBOARD BACK SUPPORT - 1pc

Part List (Box 2- WF313719/WF313722)

H

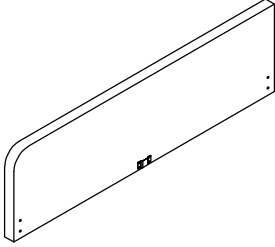

SIDE FRAME - 2pcs

Hardware List (WF313718/WF313721)

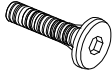
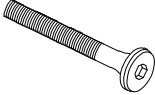
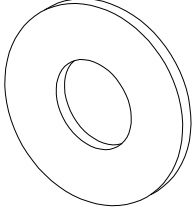
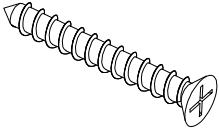
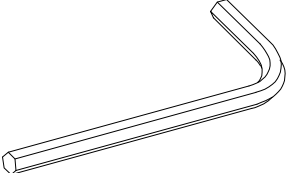
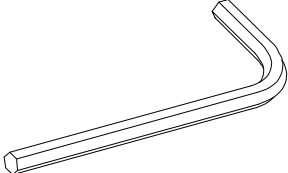
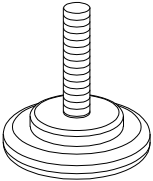
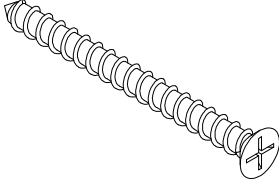
<p>1</p>  <p>JCBB M8 x 16mm (8 pcs)</p>	<p>2</p>  <p>JCBC M6 x 45mm (7 pcs)</p>	<p>3</p>  <p>M6 Flat Washer (4 pcs)</p>
<p>4</p>  <p>CSK SCREW M4 x 30mm (26pcs)</p>	<p>5</p>  <p>Allen Key M4 (1pc)</p>	<p>6</p>  <p>Allen Key M5 (1pc)</p>
<p>7</p>  <p>BASE GLIDE (3pcs)</p>	<p>8</p>  <p>CSK SCREW M4 x 45mm (2pcs)</p>	

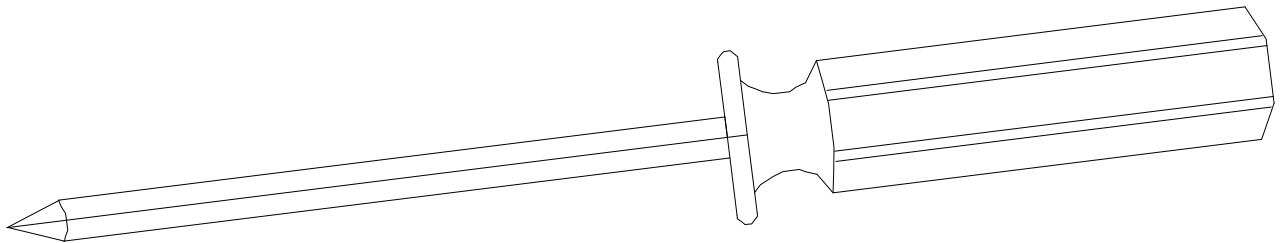

Assembly Tools
Required (Not Included)

Assembly Step

1

*ASSEMBLY BOTH SIDE FRAME (H) (x2)
WITH WOODEN LEG (F) (x4)

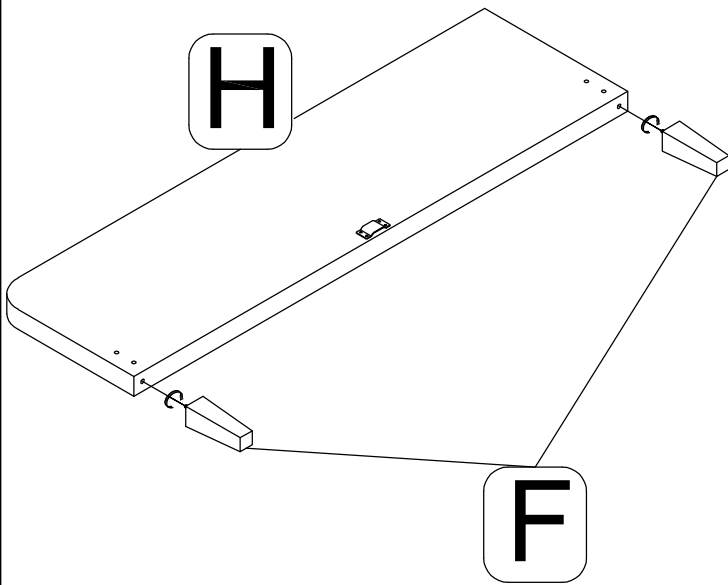

2

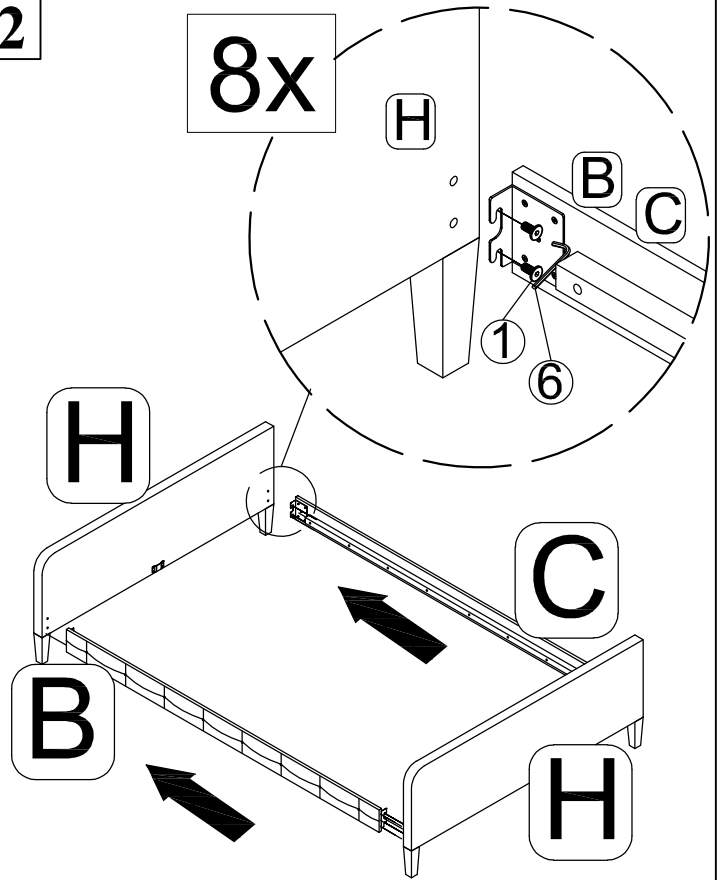

3

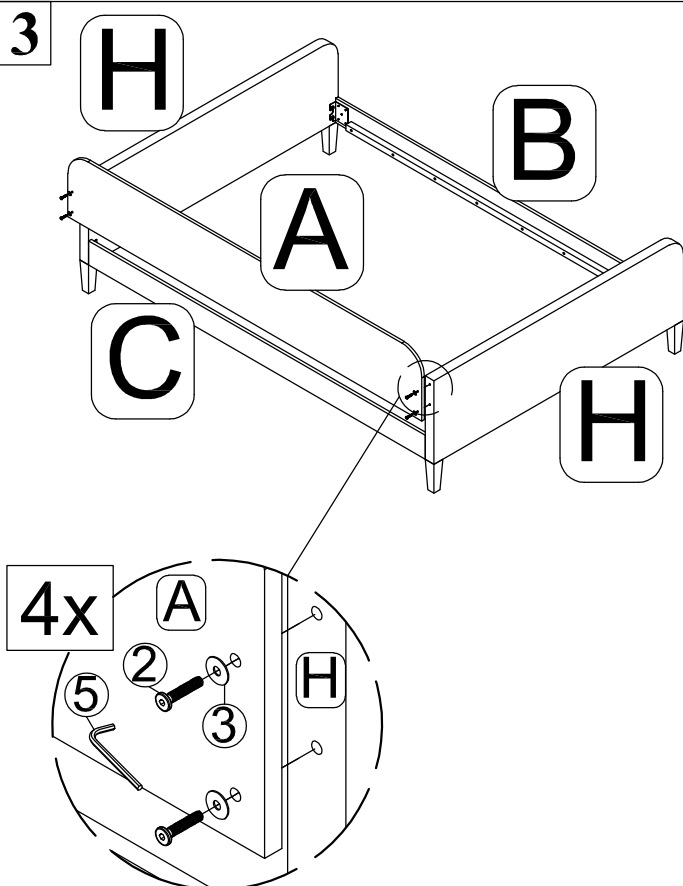

4

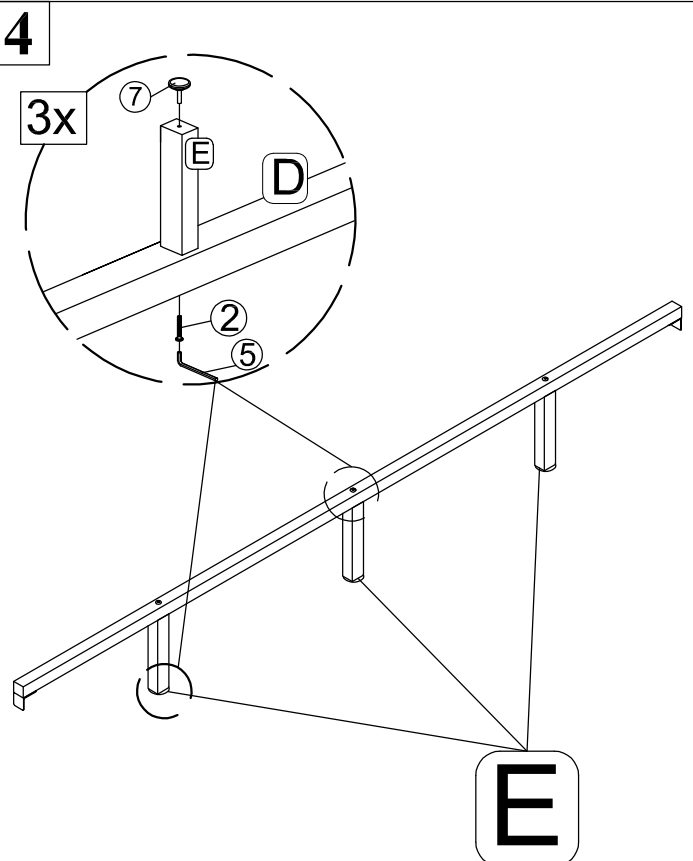

Assembly Step

5

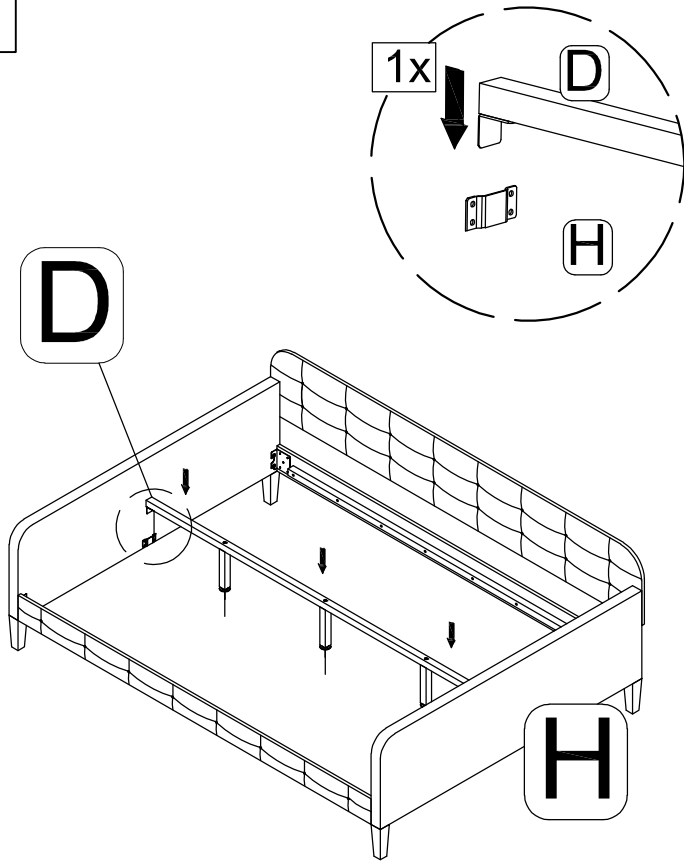

6

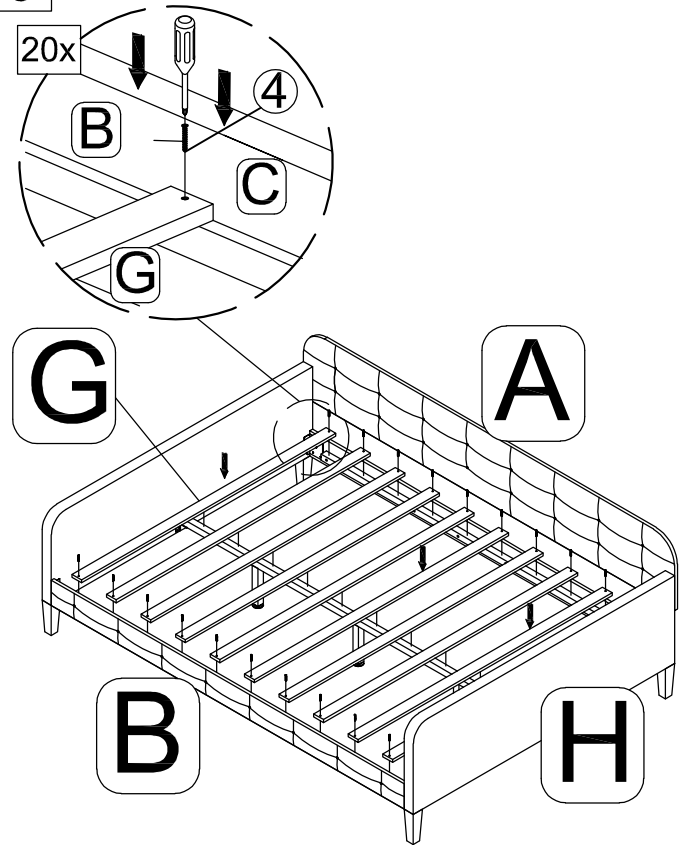

7

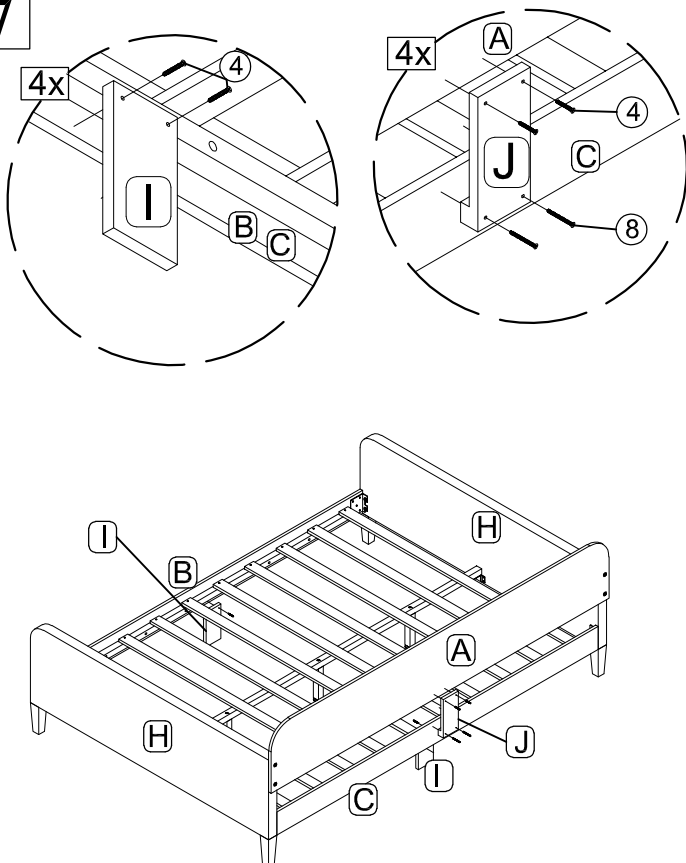

FULLY COMPLETED ASSEMBLY

