

ASSEMBLY INSTRUCTION

SKU CODE: (WF323858/WF323859/WF323860)

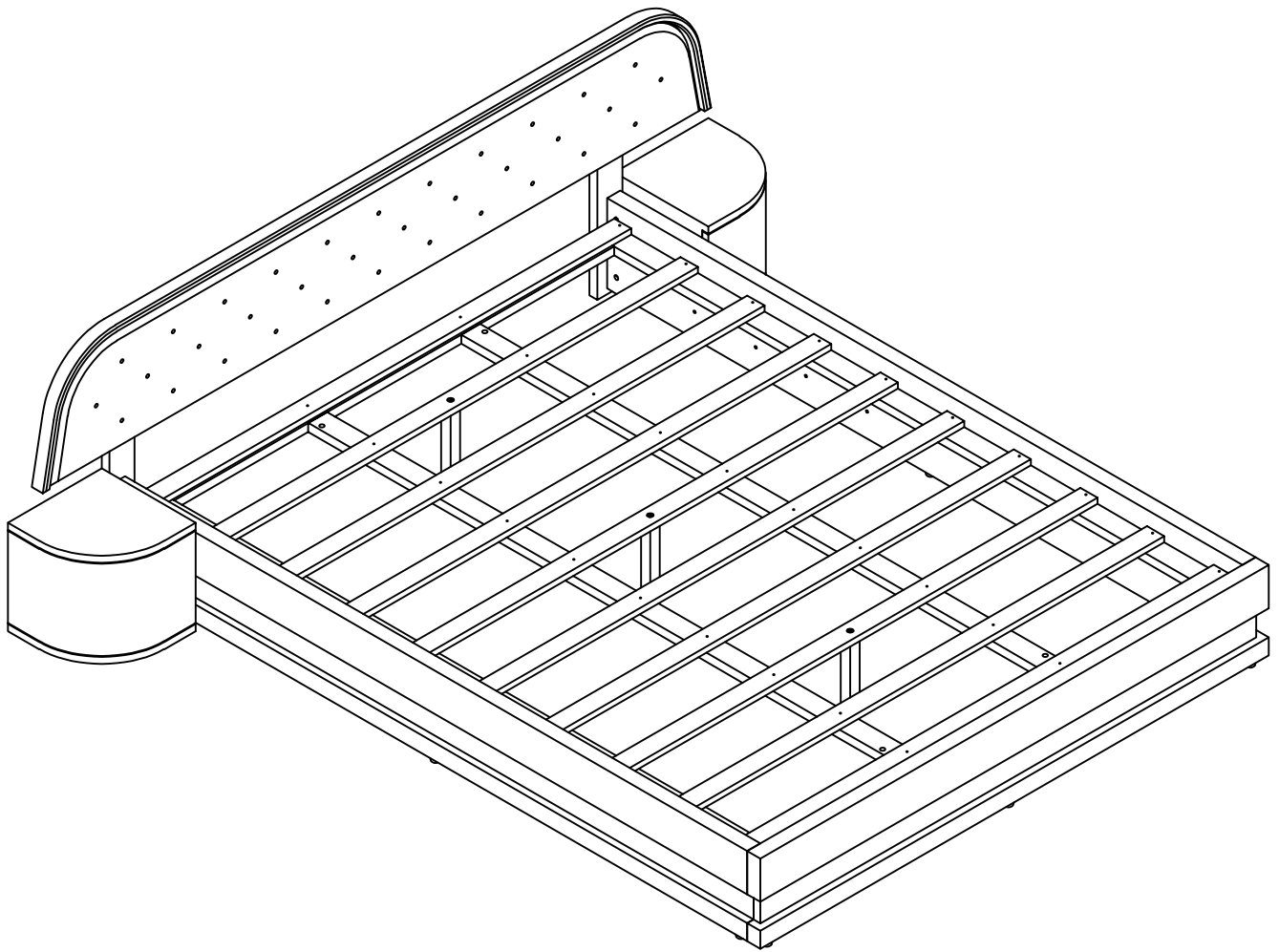

ASSEMBLY INSTRUCTION

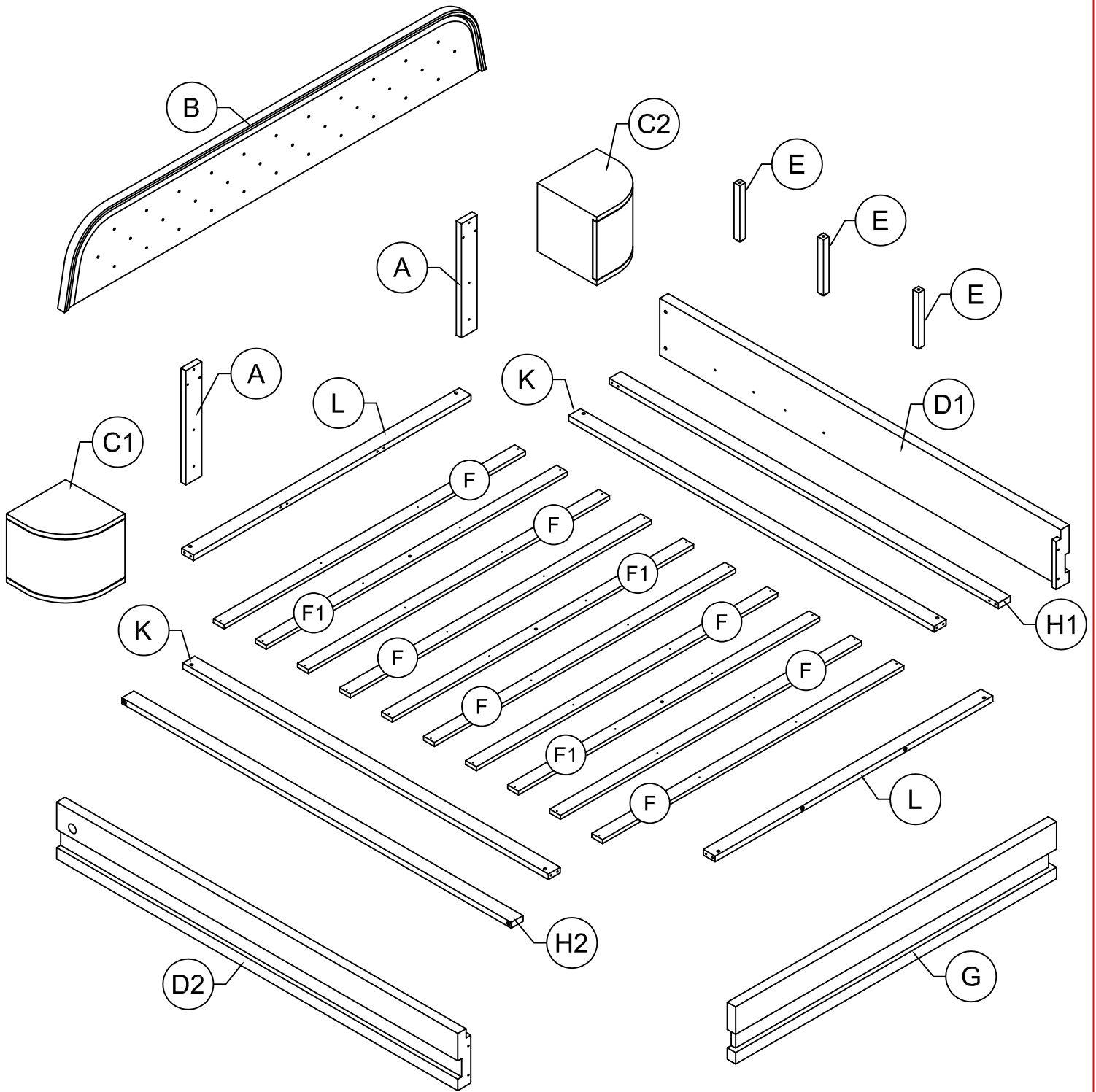

Part List (WF323858)

C1

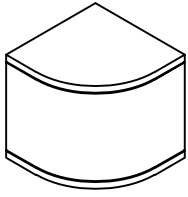

Cabinet - 1pc

C2

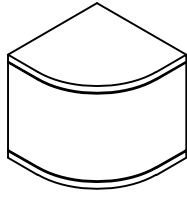

Cabinet - 1pc

Part List (WF323859)

A



Legs HB - 2pcs

B

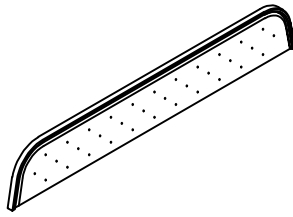

Headboard - 1pc

F

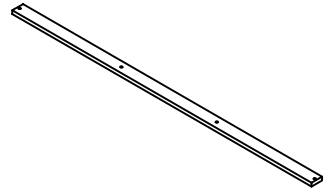

Slats - 7pcs

F1

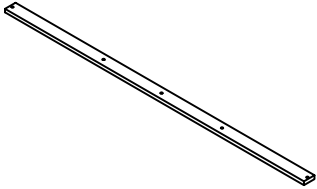

Slats - 3pcs

E



Legs support - 3pcs

Part List (WF323860)

D1

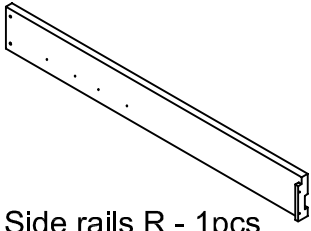

Side rails R - 1pcs

D2

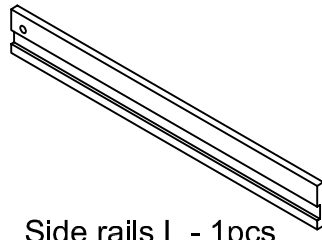

Side rails L - 1pcs

G

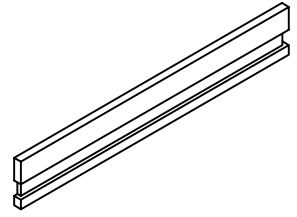

Footboard - 1pcs

H1



Frame bars - 1pcs

H2

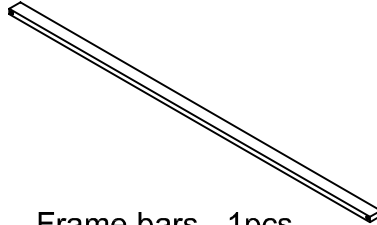

Frame bars - 1pcs

K



Frame bars - 2pcs

L

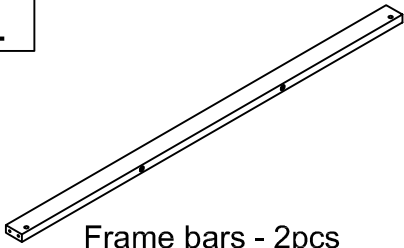

Frame bars - 2pcs

Hardware List (WF323859)

<p>1</p>  <p>1/4" x 40mm Hex-Head bolts 10pcs</p>	<p>2</p>  <p>1/4" x 12 x 15mm Horizontal -Hole bolts 12pcs</p>	<p>3</p>  <p>1/4" x 60mm Hex-Head bolts 4pcs</p>
<p>4</p>  <p>1/4" x 20mm Hex-Head bolts 17pcs</p>	<p>5</p>  <p>1/4" x 30mm Hex-Head bolts 3pcs</p>	<p>6</p>  <p>Ø8 x 30 mm Wood dowel 8pcs</p>
<p>7</p>  <p>1/4" x 100mm Hex-Head bolts 8pcs</p>	<p>8</p>  <p>M4 x 30 mm Wood Screws 41pcs</p>	<p>9</p>  <p>Fabric 1pc</p>
<p>10</p>  <p>1/4" x 20 mm Wood Screws 8pcs</p>	<p>11</p>  <p>Piston Left 1 pcs</p>	<p>12</p>  <p>Piston Right 1 pcs</p>
<p>13</p>  <p>Allen Key 1pcs</p>	<p>14</p>  <p>Carpet Fabric 1pc</p>	<p>15</p>  <p>Steel Bracket 4pcs</p>
<p>16</p>  <p>M4 x 15 mm Wood Screws 8pcs</p>	<p>17</p>  <p>1 2 USB Power Socket 1pcs</p>	<p>18</p>  <p>Plastic Feet(Ø32x16) 9pcs</p>

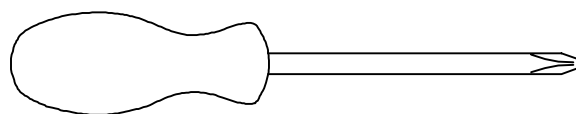

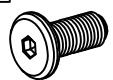

Assembly Tools Required (Not Included)

STEP 1: Following below illustration:

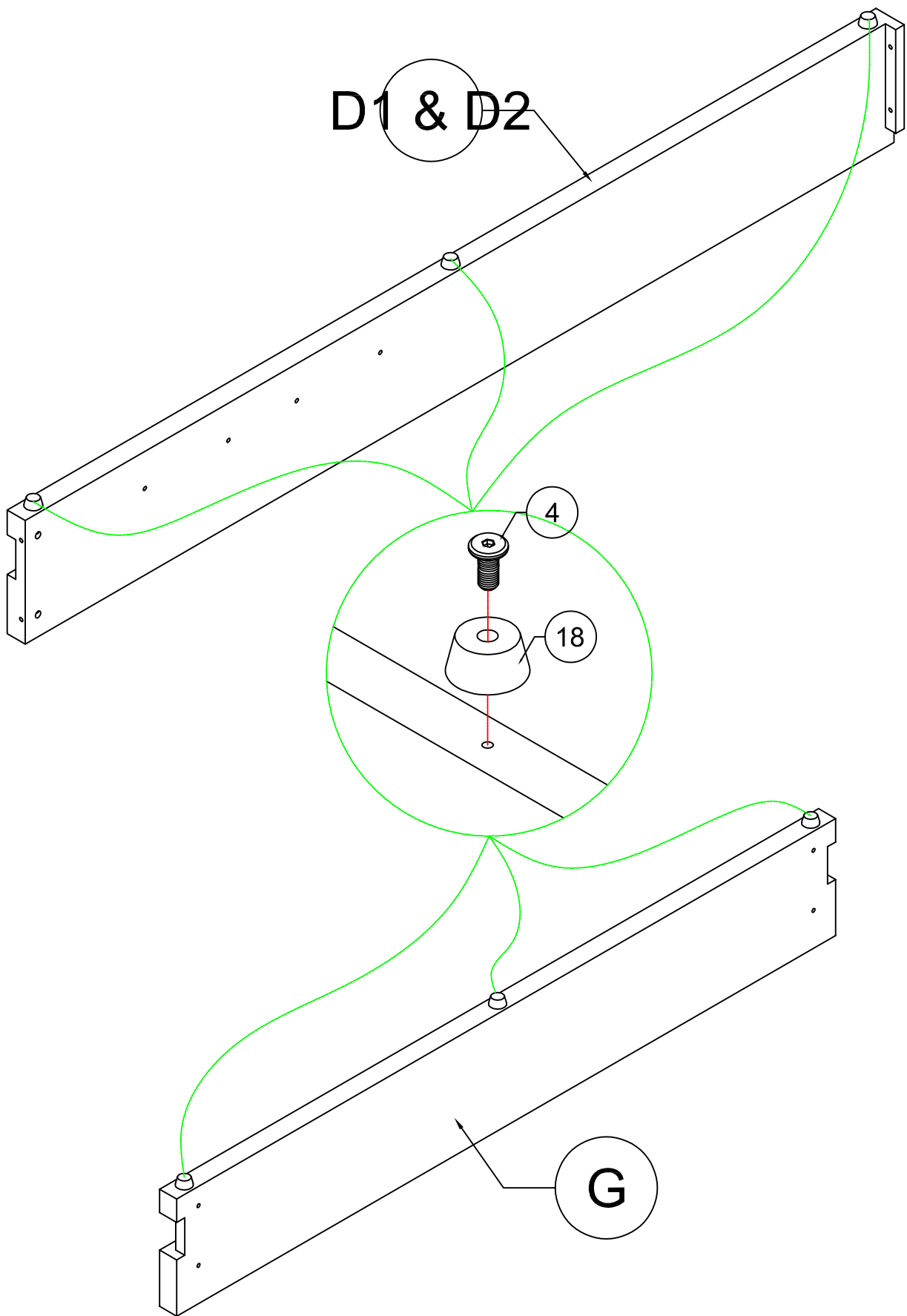
18	4
	
9pcs	9pcs

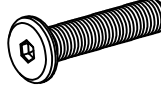

STEP 2: Following below illustration:

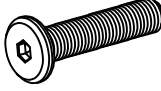
1	2	3
		
4pcs	4pcs	4pcs

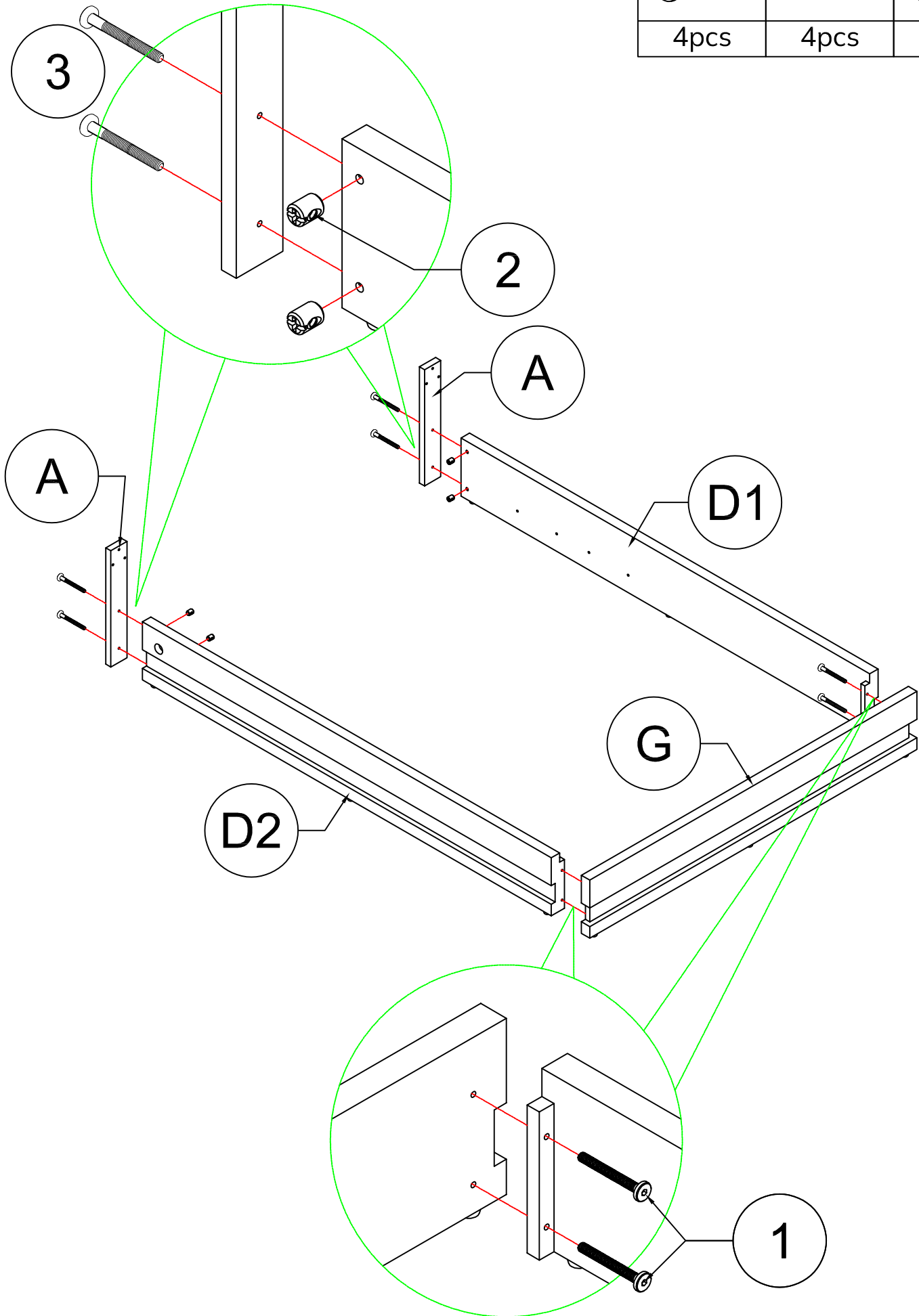

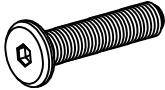

STEP 3: Following below illustration:

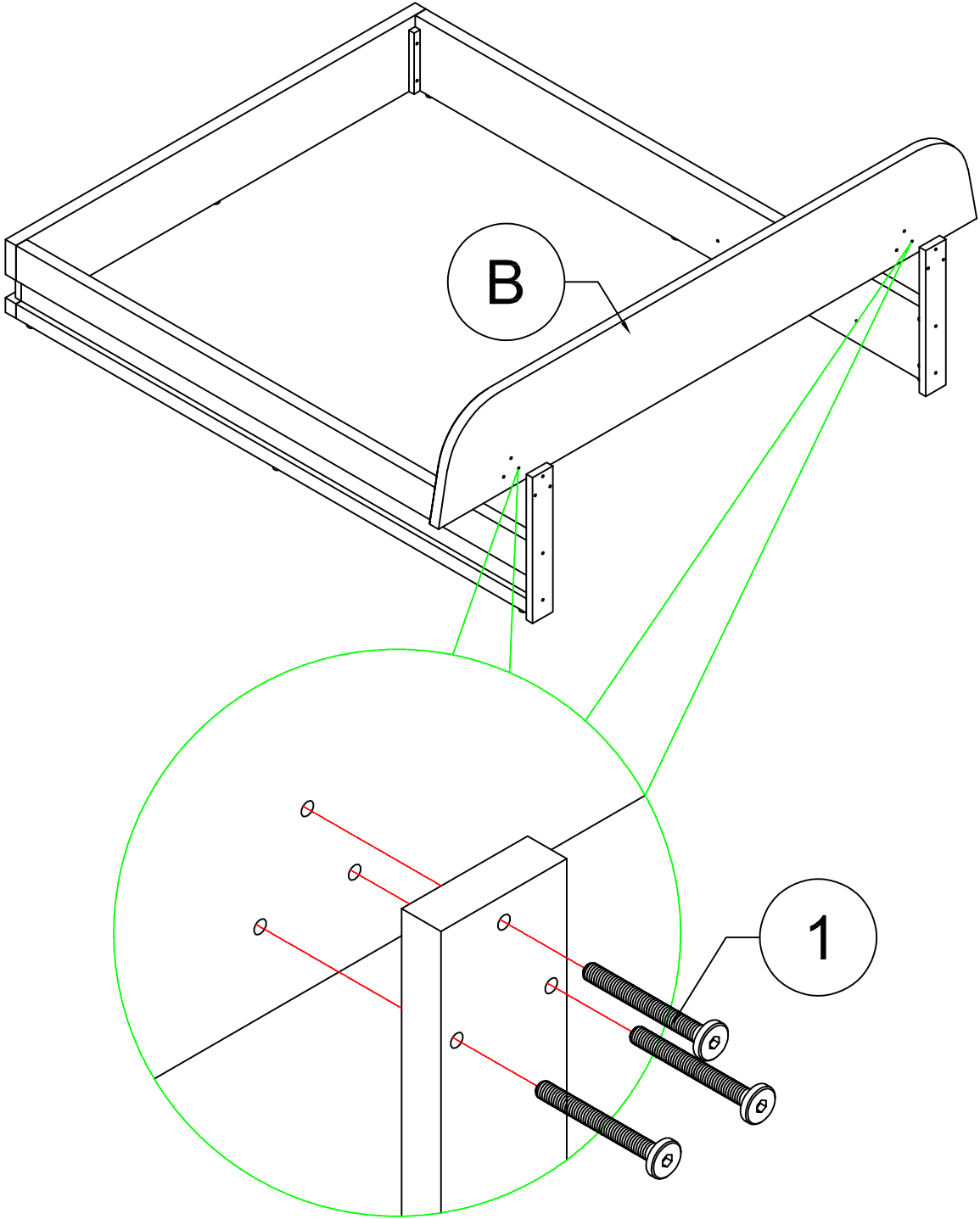
1

6pcs

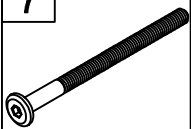
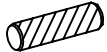

STEP 4: Following below illustration:

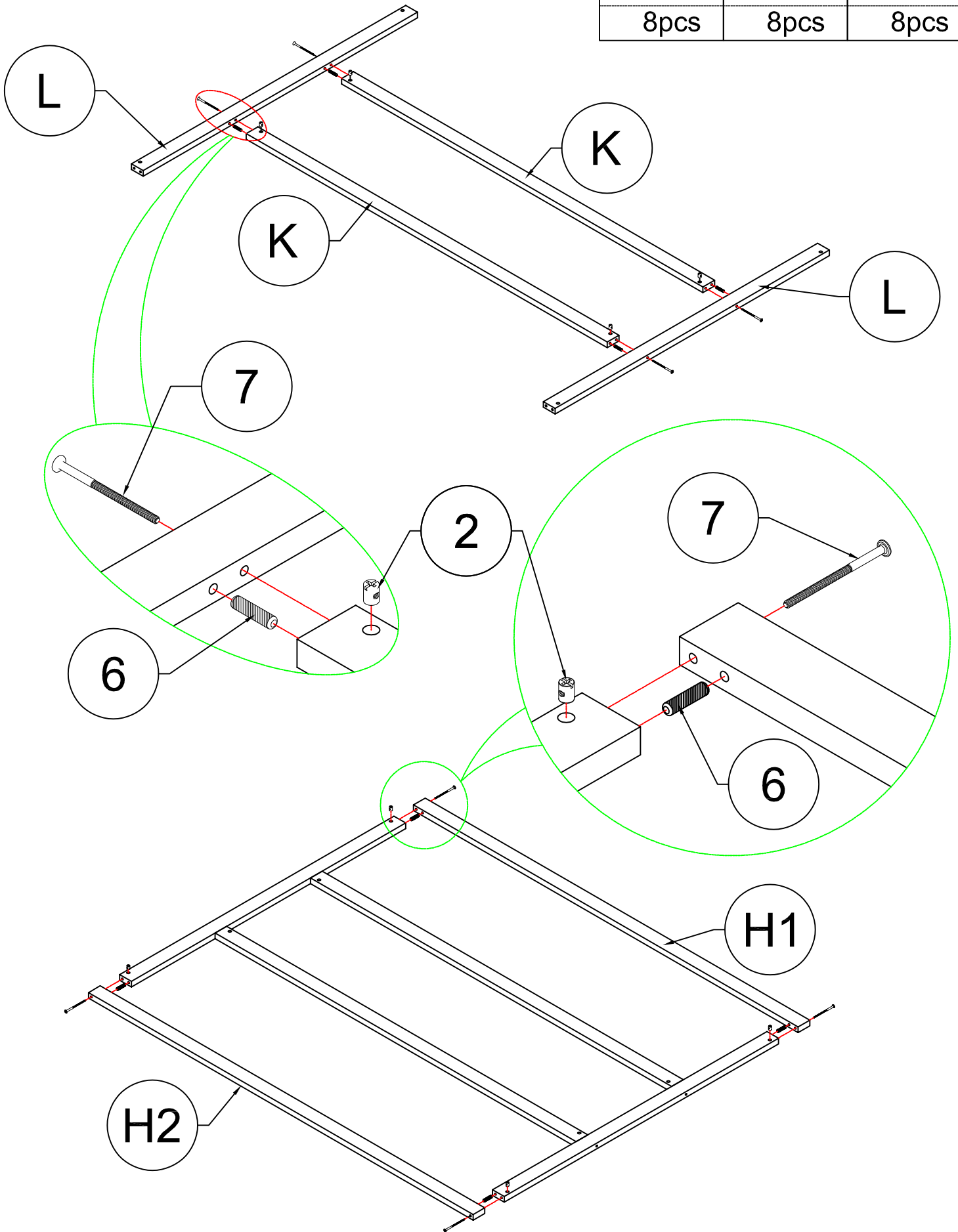
7	6	2
		
8pcs	8pcs	8pcs

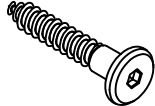
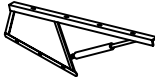
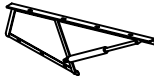

STEP 6: Following below illustration:

10	11	12
		
8pcs	1pcs	1pcs

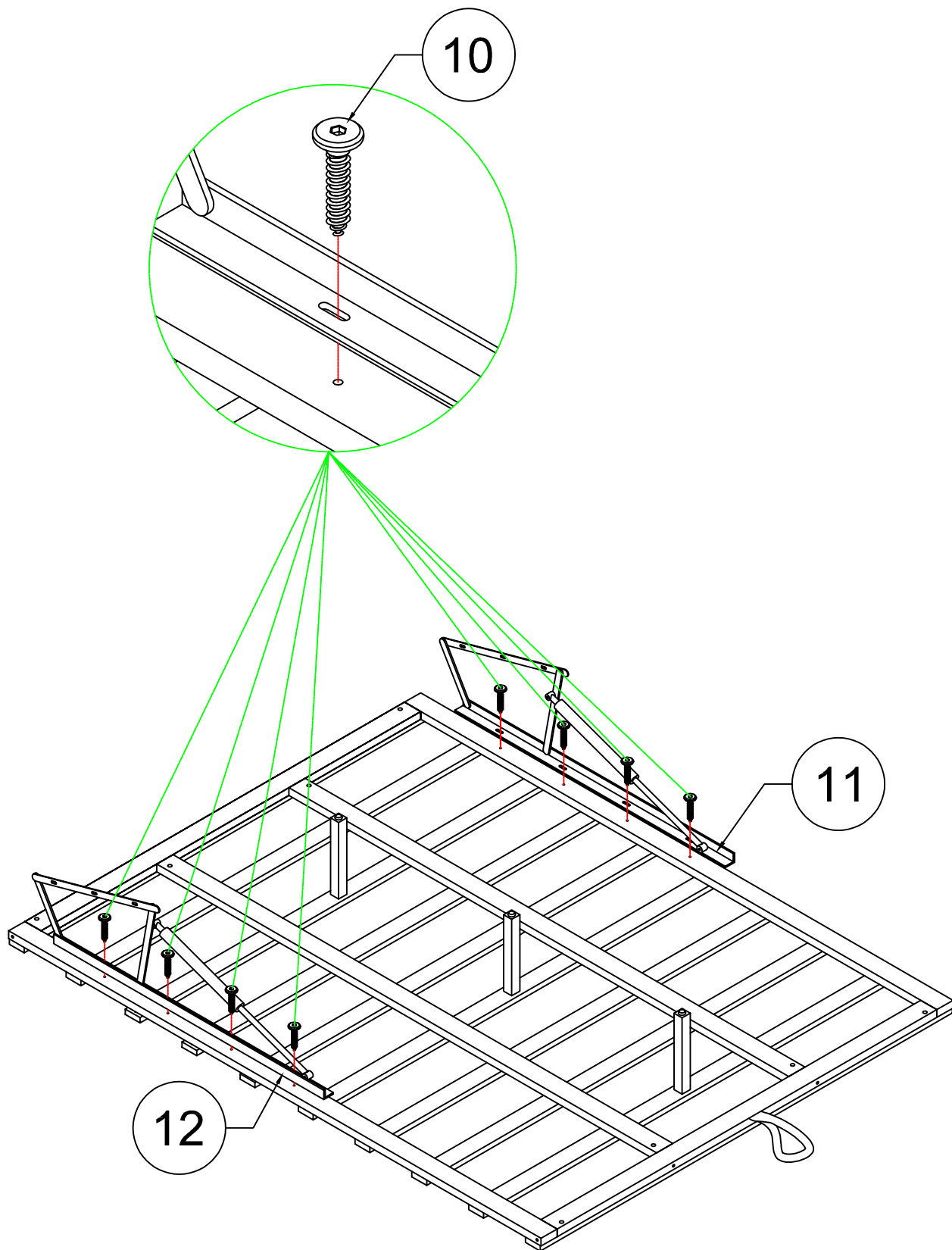

STEP 7: Following below illustration:

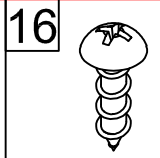

8pcs

4

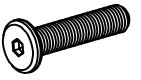

8pcs

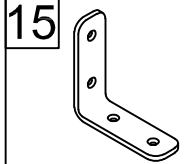

4pcs

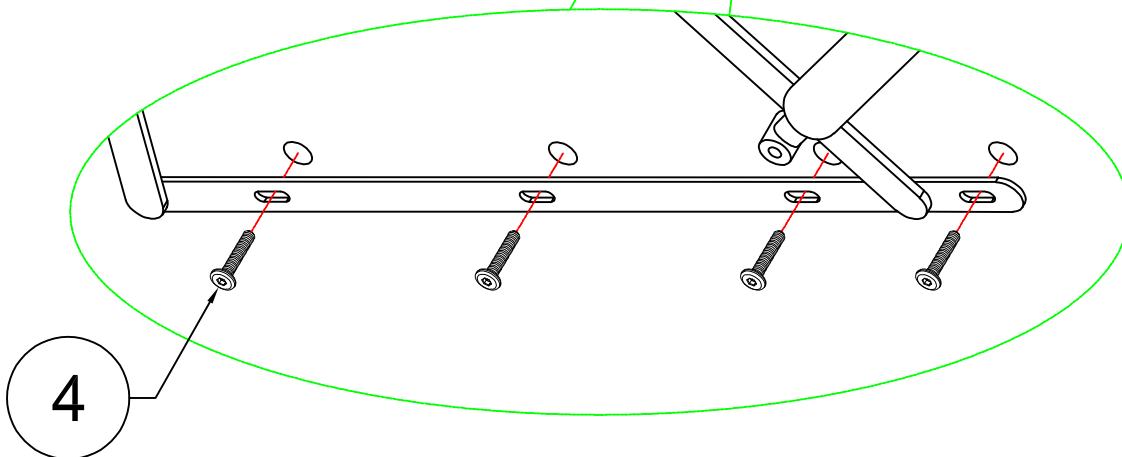
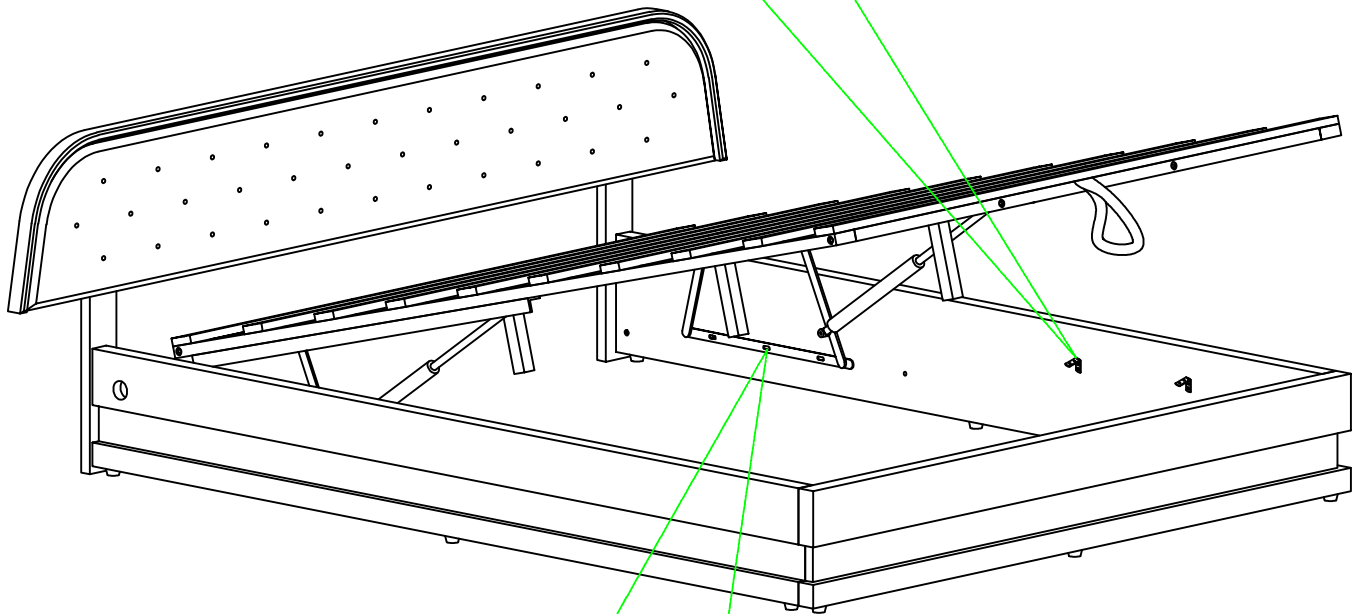
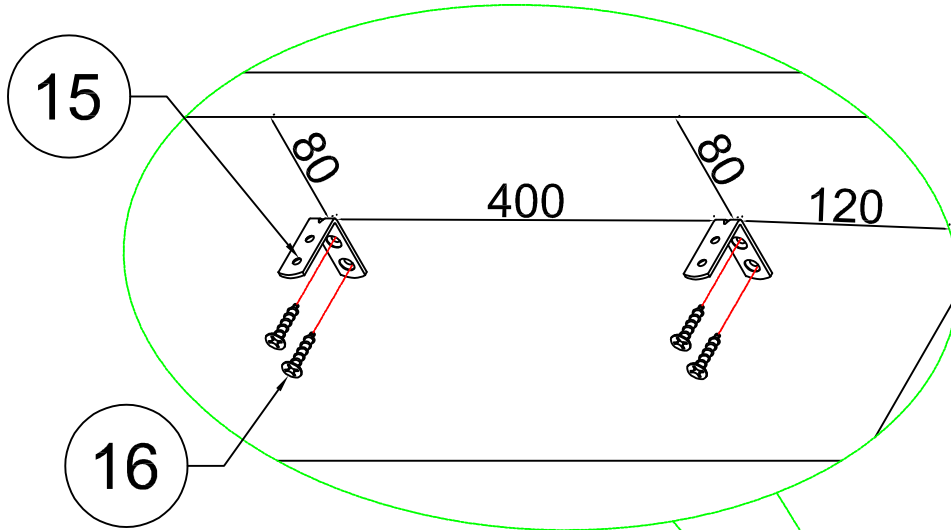

STEP 8: Following below illustration:

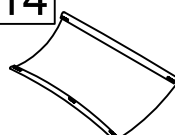
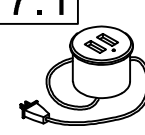
14	17.1
	
1pcs	1pcs

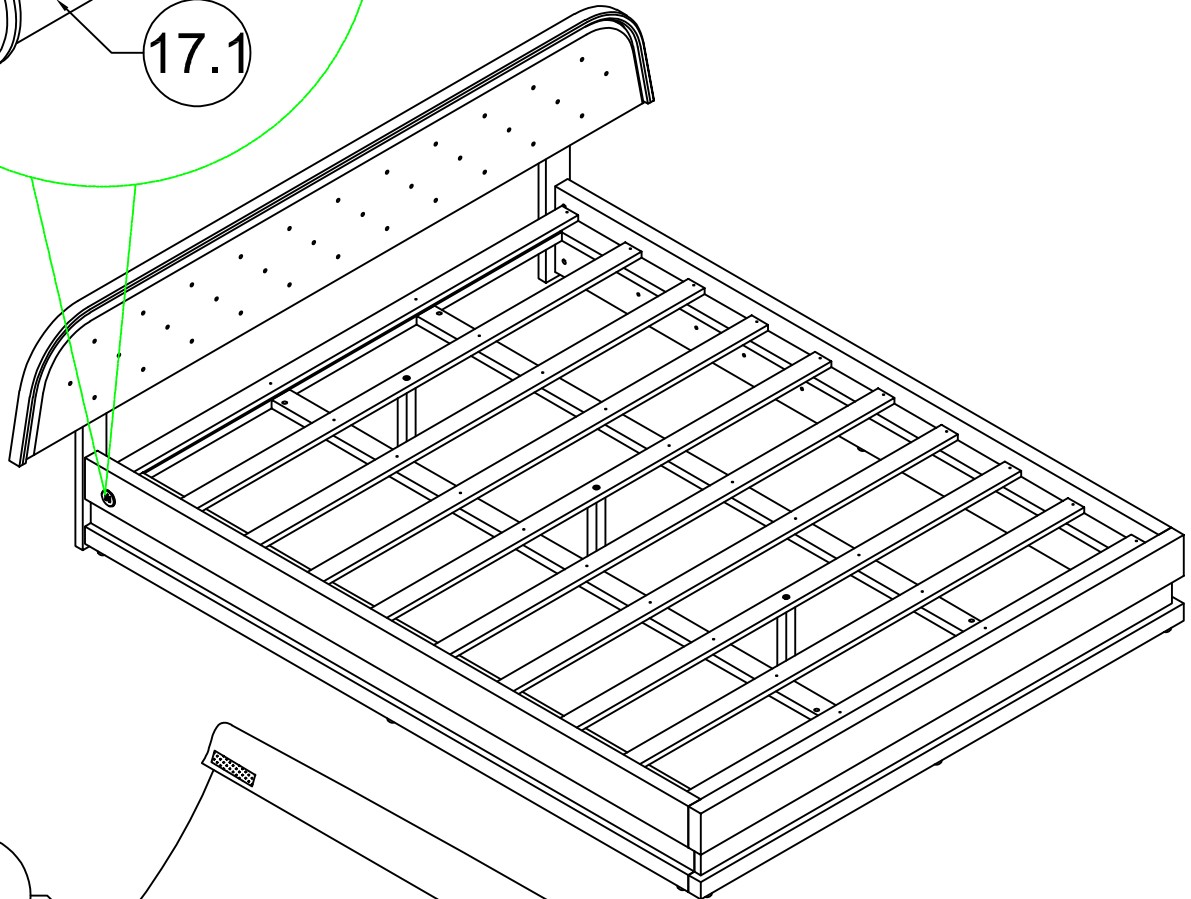
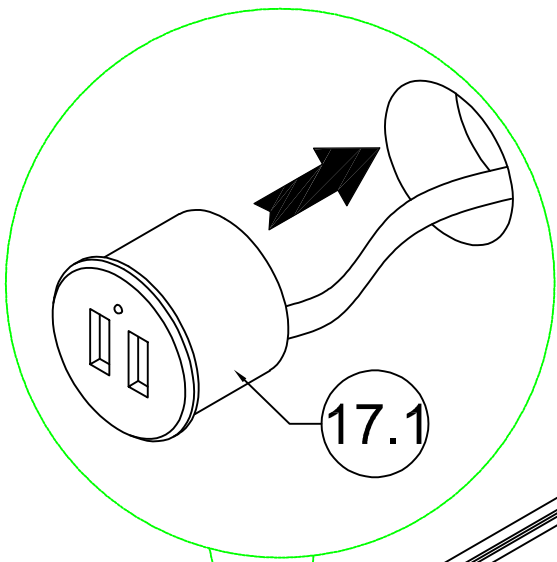

14

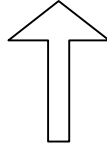

Use tape to secure the bed

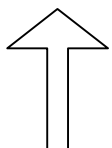

STEP 9: Following below illustration:

17.2



1pcs

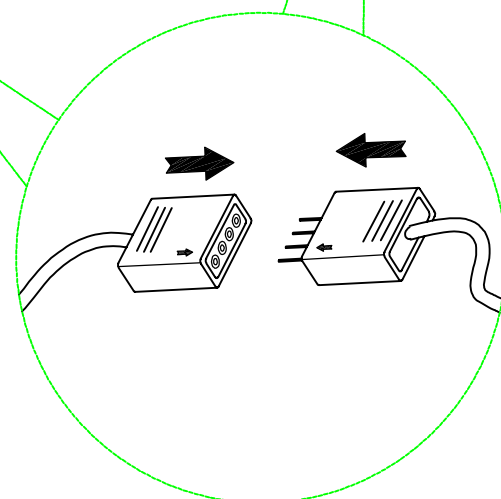
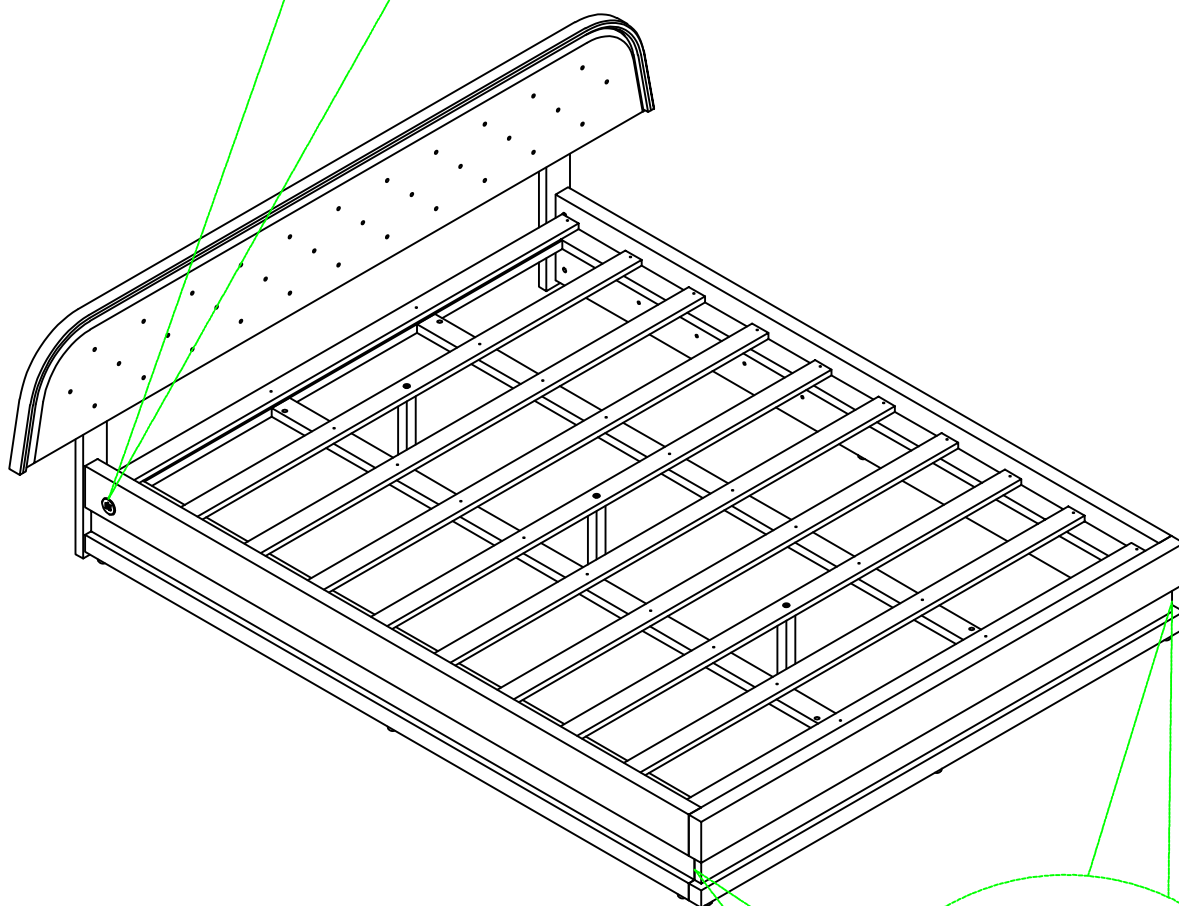
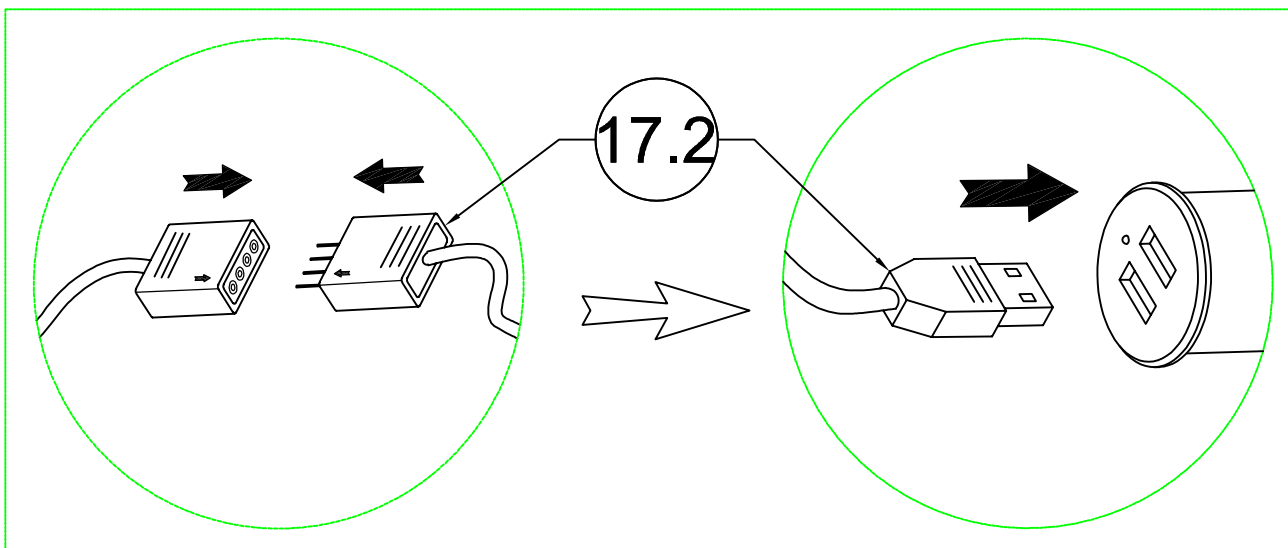

STEP 10: Following below illustration:

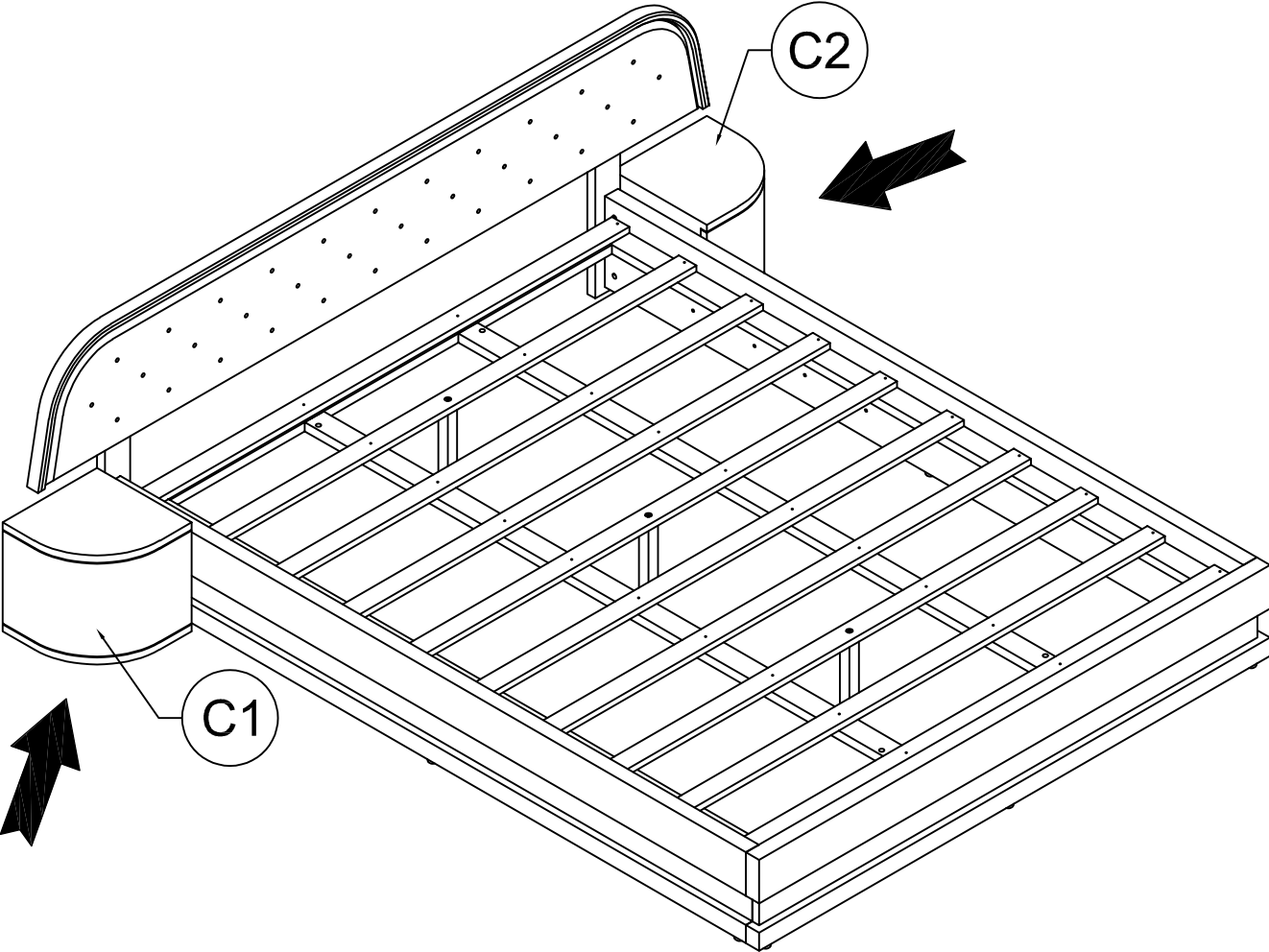

FINISH

