

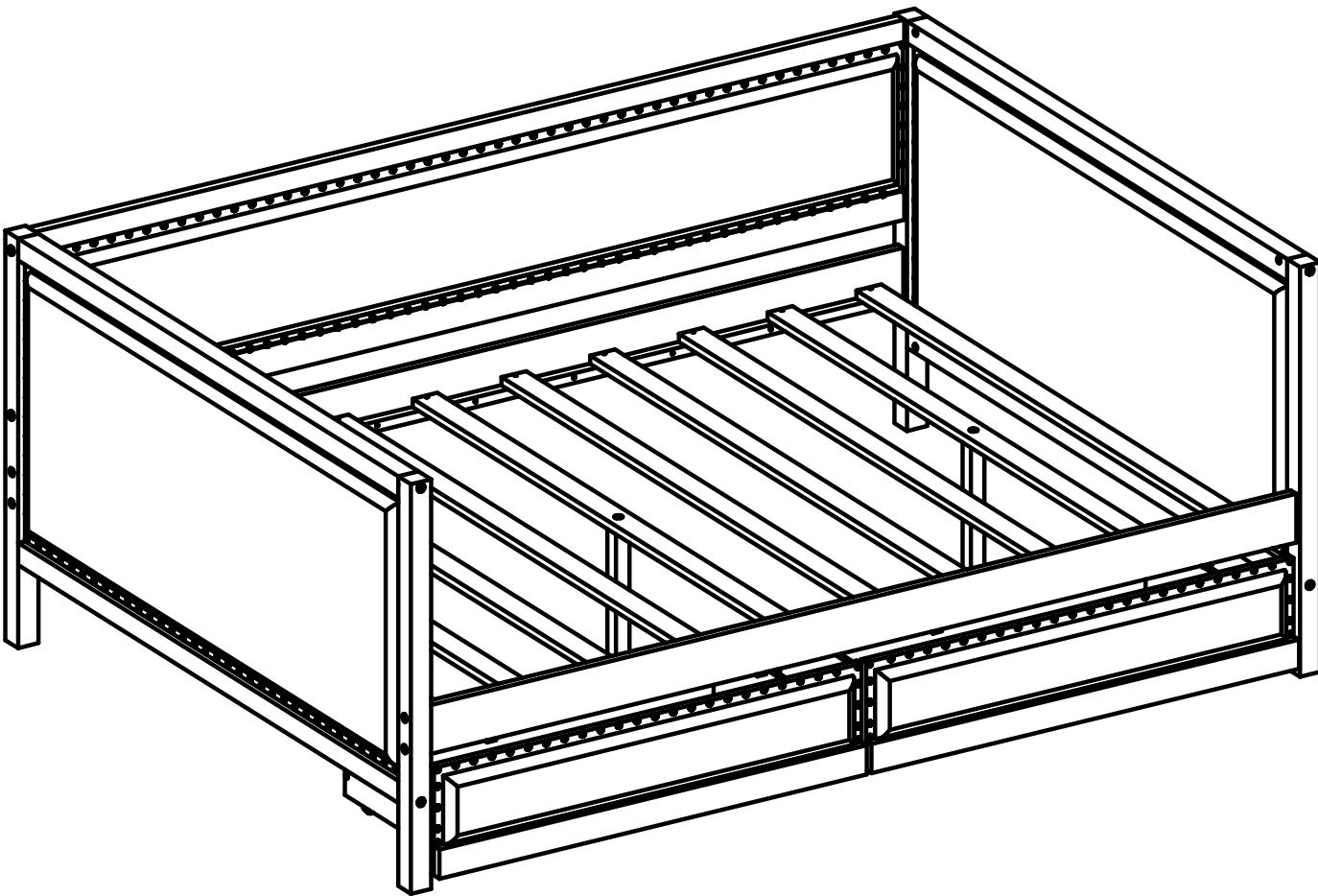

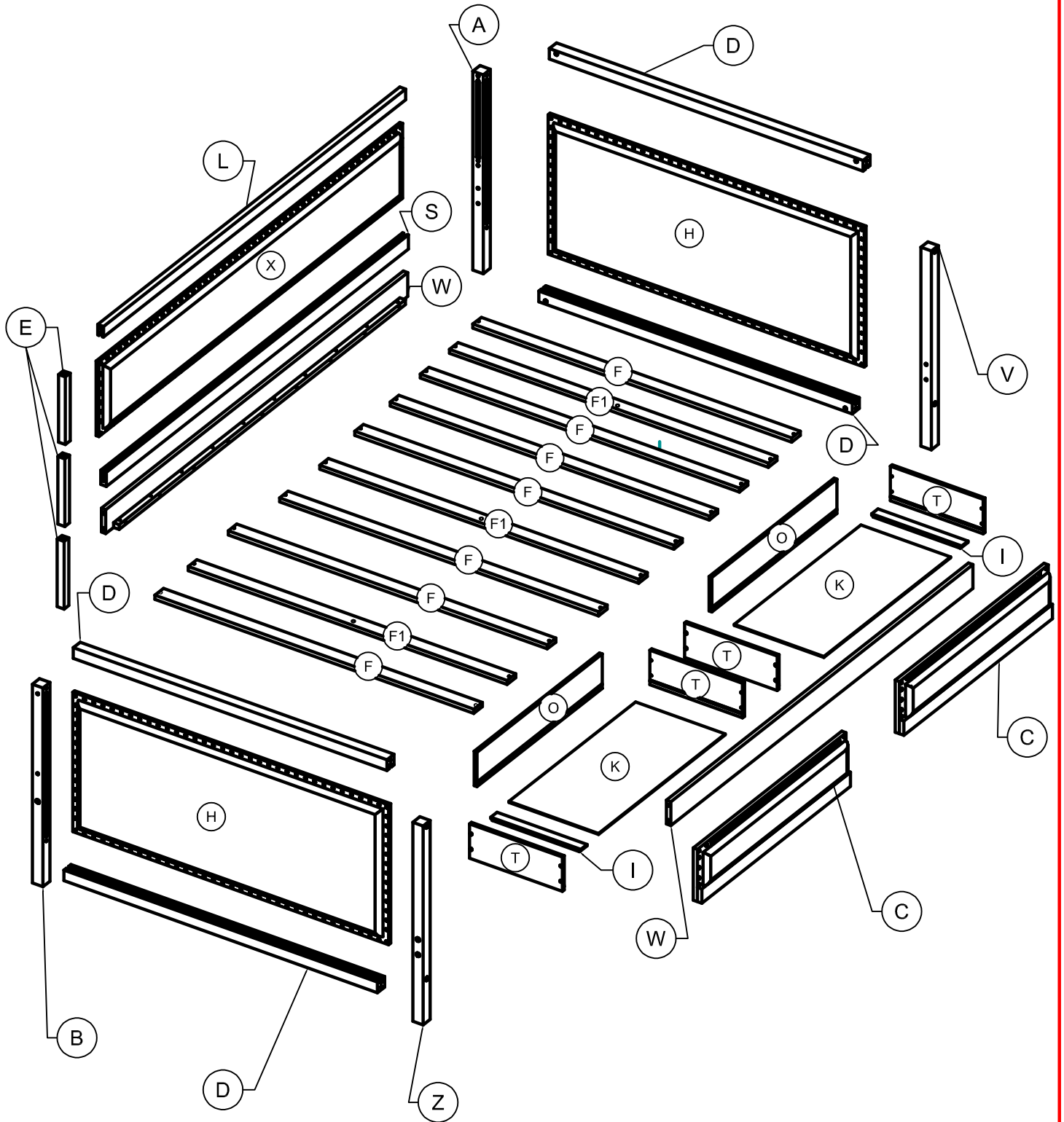

**ASSEMBLY INSTRUCTION**  
SKU CODE: (WF324198/WF324199)





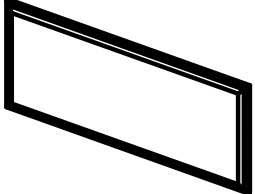

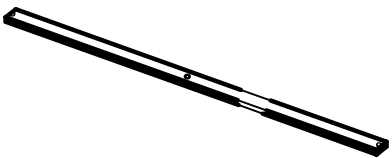
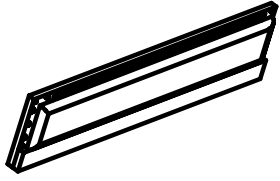
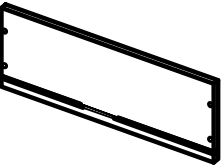
# ASSEMBLY INSTRUCTION

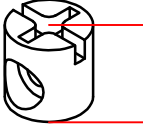
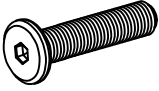
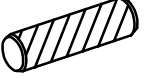
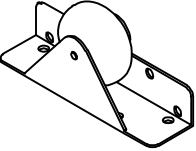
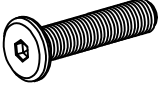

# Part List (WF324198)

<p><b>H</b></p>  <p>Side Rails - 2pcs</p>	<p><b>F</b></p>  <p>Slats - 7pcs</p>	<p><b>F1</b></p>  <p>Slats - 3pcs</p>
<p><b>C</b></p>  <p>Drawers - Font Panel - 2pcs</p>	<p><b>T</b></p>  <p>Drawers - Side Panel - 4pcs</p>	<p><b>K</b></p>  <p>Drawers - Bottom Panel - 2pcs</p>





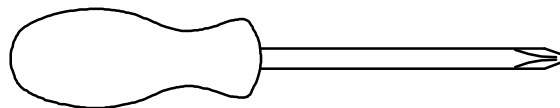



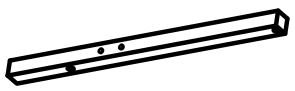

# Hardware List (WF324199)

<p>1</p>  <p>Ø1/4" x 15 mm Horizontal-Hole bolts 20pcs</p>	<p>2</p>  <p>1/4" x 80mm Hex-Head bolts 20pcs</p>	<p>3</p>  <p>Ø8 x 30 mm Wood dowel 12pcs</p>
<p>4</p>  <p>Wheels 8psc</p>	<p>5</p>  <p>1/4" x 30mm Hex-Head bolts 3pcs</p>	<p>6</p>  <p>Plastic Drawer Stopper 4pcs</p>
<p>7</p>  <p>M4 x 15 mm Wood Screws 20pcs</p>	<p>8</p>  <p>M4 x 30 mm Wood Screws 36pcs</p>	<p>9</p>  <p>Allen Key 1pcs</p>

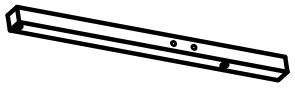

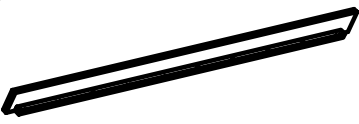

**Assembly Tools Required (Not Included)**

# Part List (WF324199)

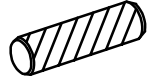

<p><b>A</b></p>  <p>Frontleg (R) - 1pcs</p>	<p><b>D</b></p>  <p>Horizontal Bars - 4pcs</p>	<p><b>V</b></p>  <p>Backleg(R) - 1pcs</p>
<p><b>E</b></p>  <p>Support Leg - 3pcs</p>	<p><b>B</b></p>  <p>Frontleg (L) - 1pcs</p>	<p><b>Z</b></p>  <p>BackLeg (L) - 1pcs</p>
<p><b>L</b></p>  <p>Horizontal Bar - Above- 1pcs</p>	<p><b>S</b></p>  <p>Horizontal Bar - Below - 1pcs</p>	<p><b>W</b></p>  <p>Side Panel - 2pcs</p>
<p><b>X</b></p>  <p>Lean Back - 1pcs</p>	<p><b>O</b></p>  <p>Drawers - Back Panel - 2pcs</p>	<p><b>I</b></p>  <p>Drawers - Support Bottom - 2pcs</p>

# STEP 1: Following below illustration:

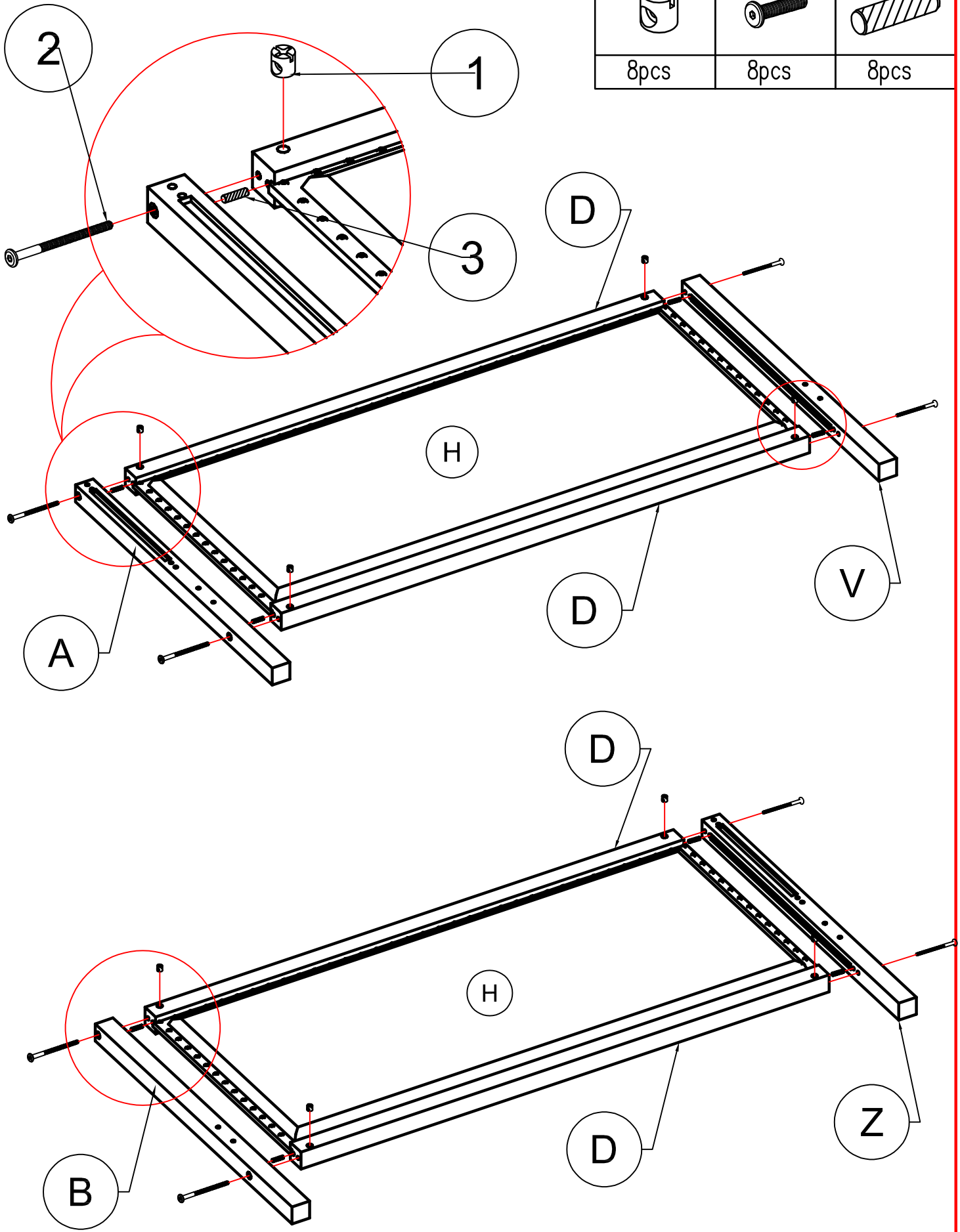
1	2	3
		
8pcs	8pcs	8pcs





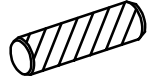

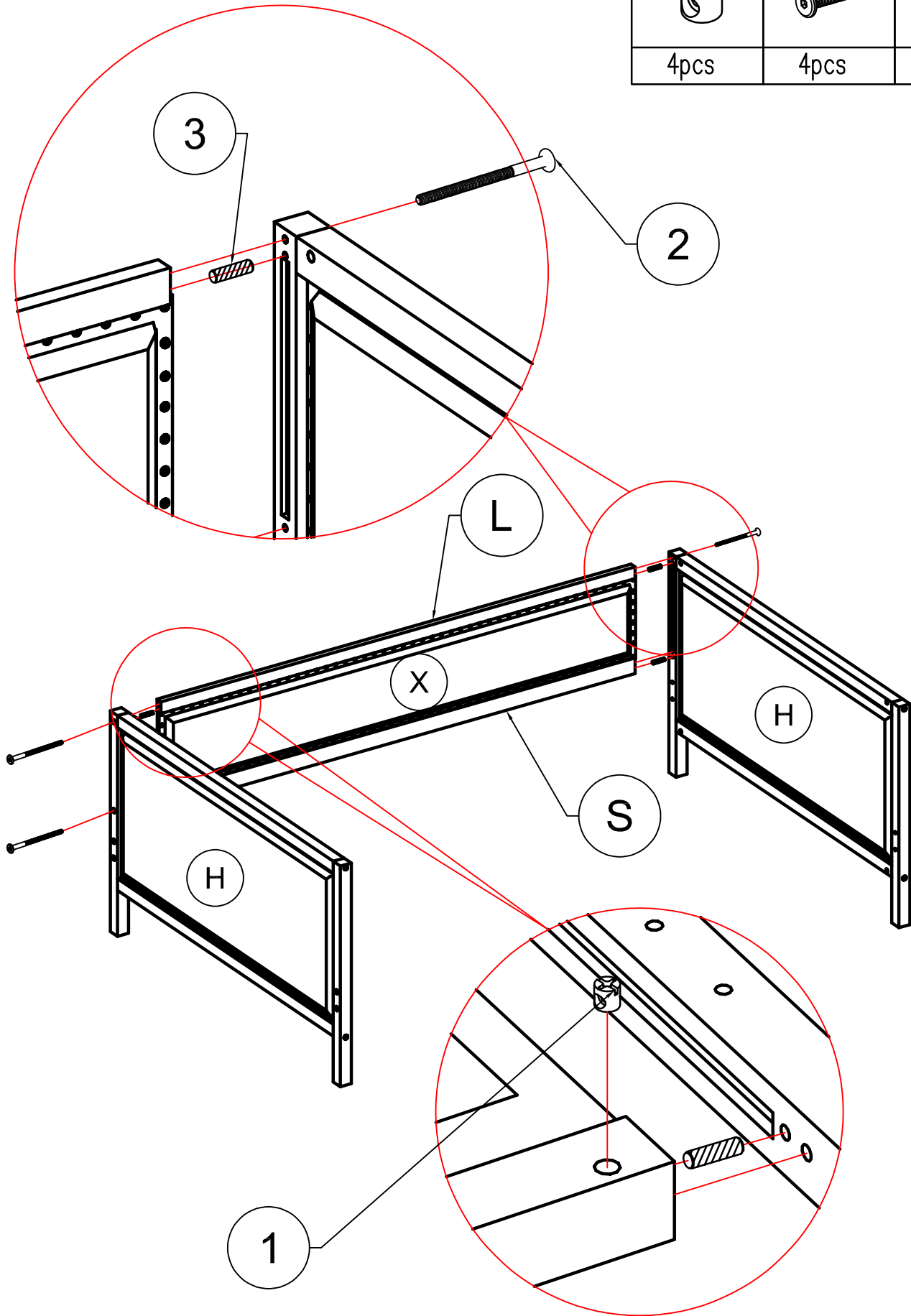
# STEP 2: Following below illustration:

1	2	3
		
4pcs	4pcs	4pcs



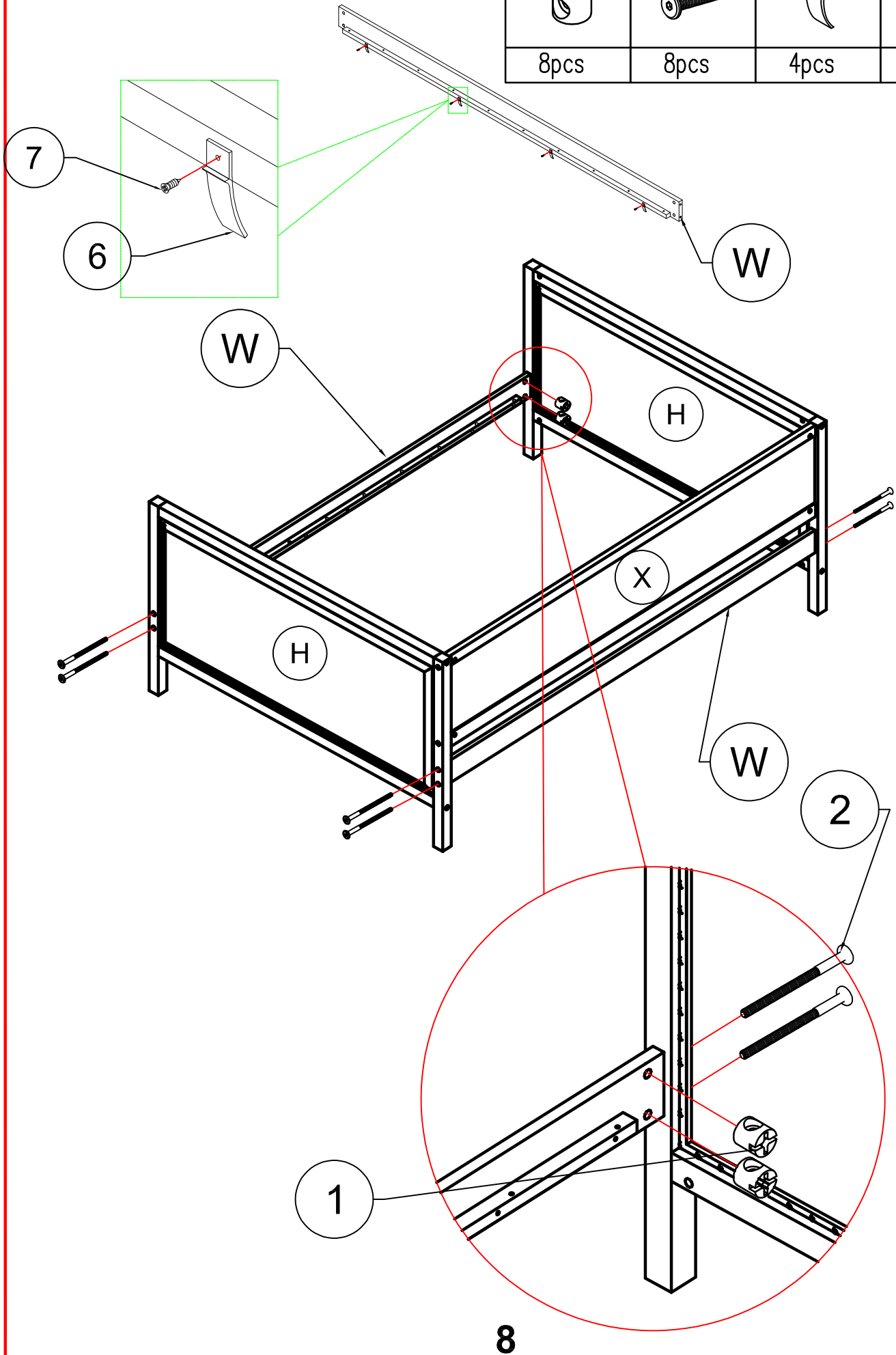

# STEP 3: Following below illustration:

1	2	6	7
			
8pcs	8pcs	4pcs	4pcs





# STEP 4: Following below illustration:

5	8
	
3pcs	20pcs

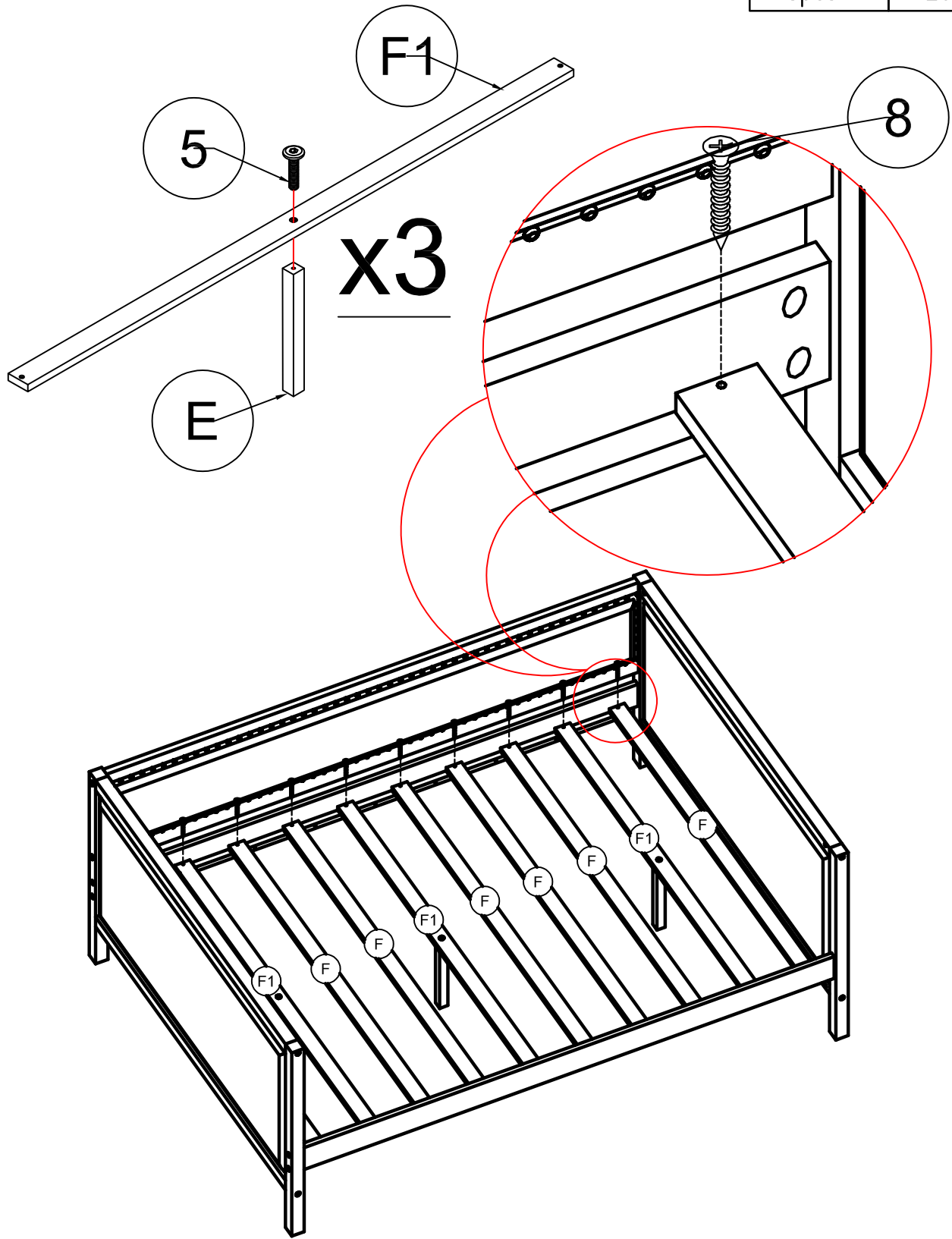

# STEP 5: Following below illustration:

8



8pcs

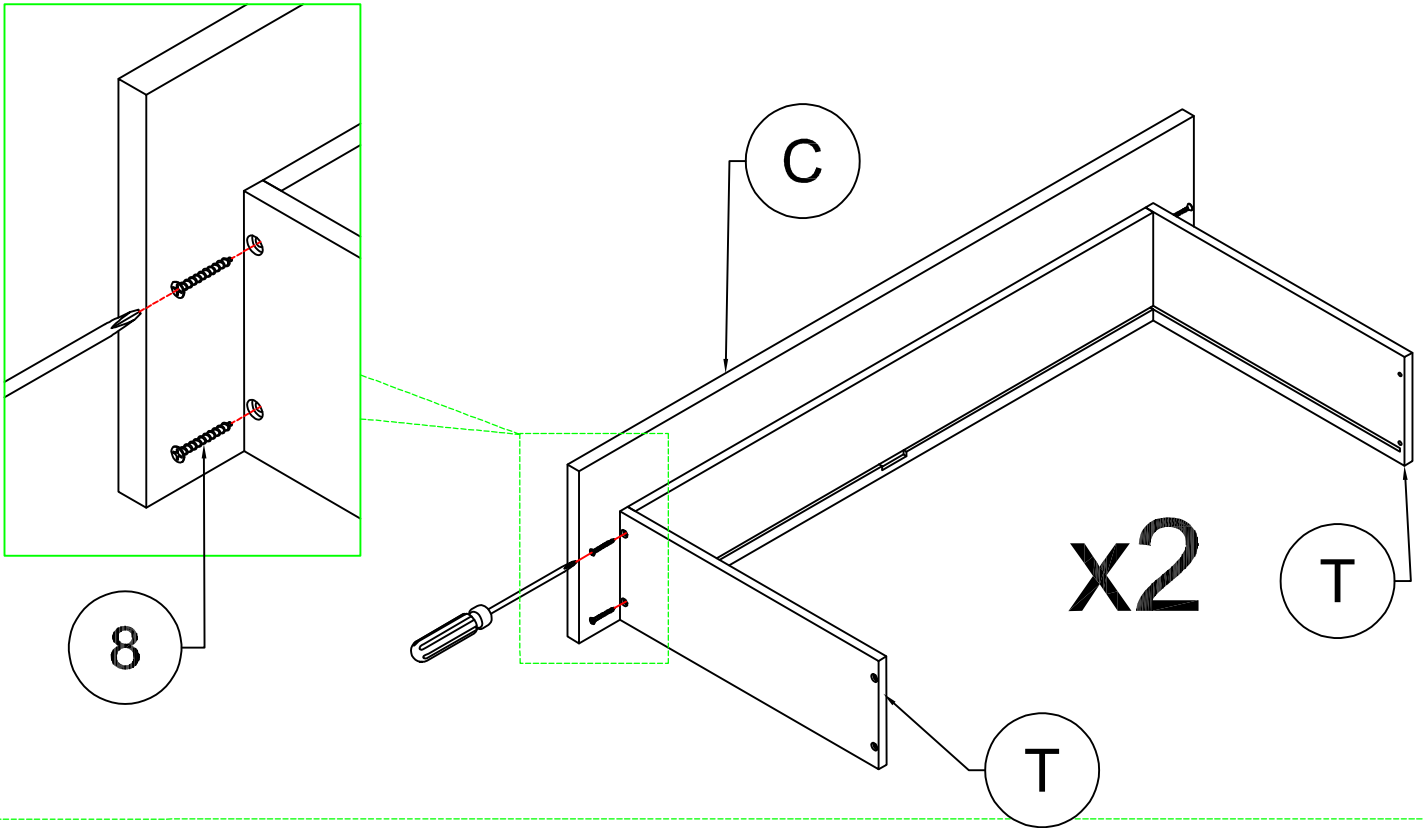

# STEP 5.1: Following below illustration:

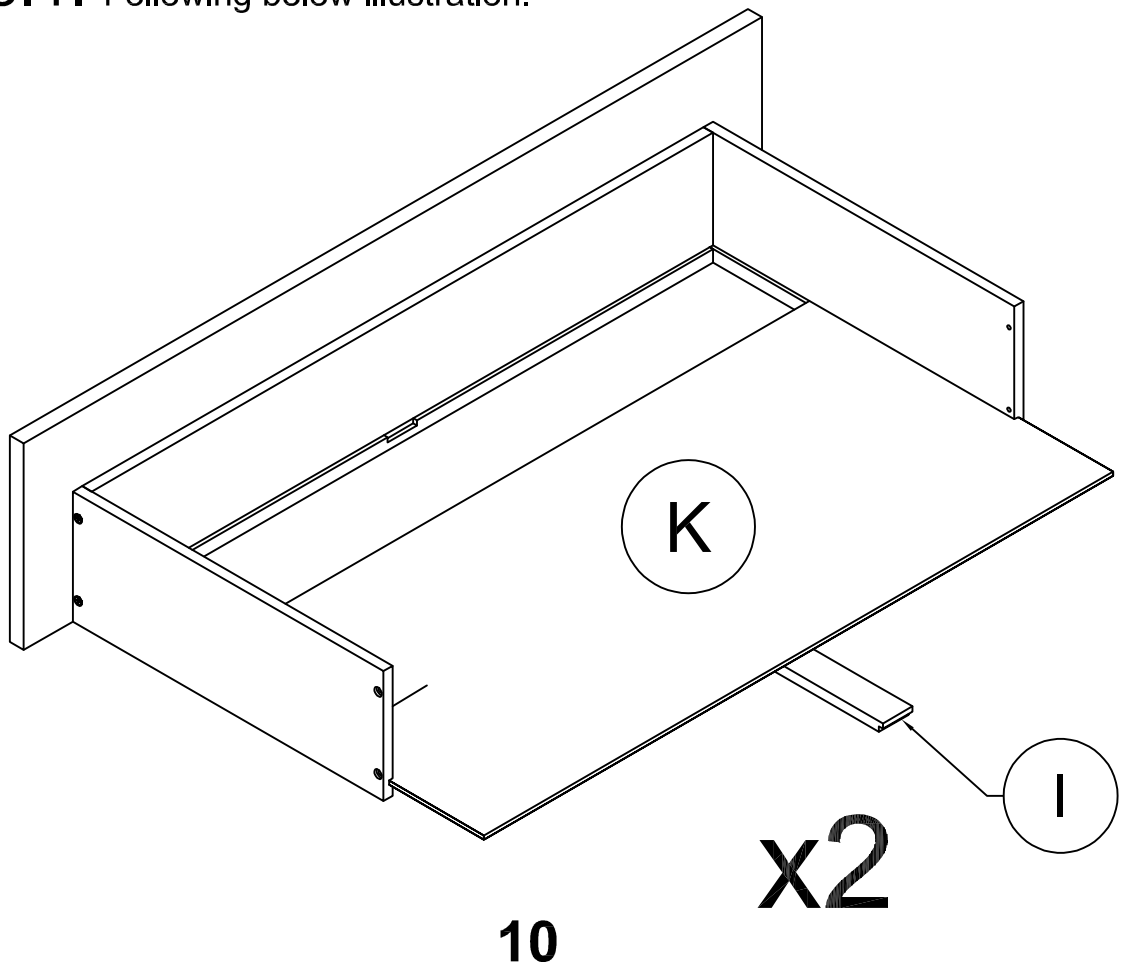

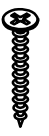

# STEP 6: Following below illustration:

8	
8pcs	

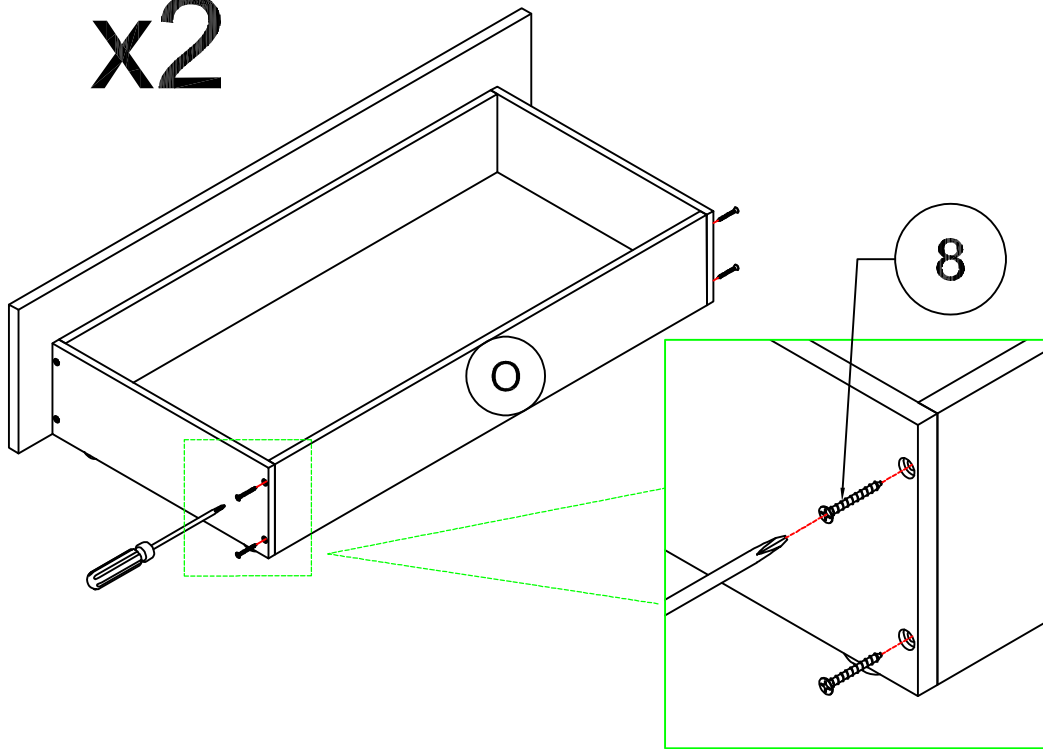
x2

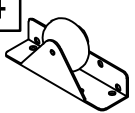

# STEP 6.1: Following below illustration:

4		7	
8pcs		16pcs	

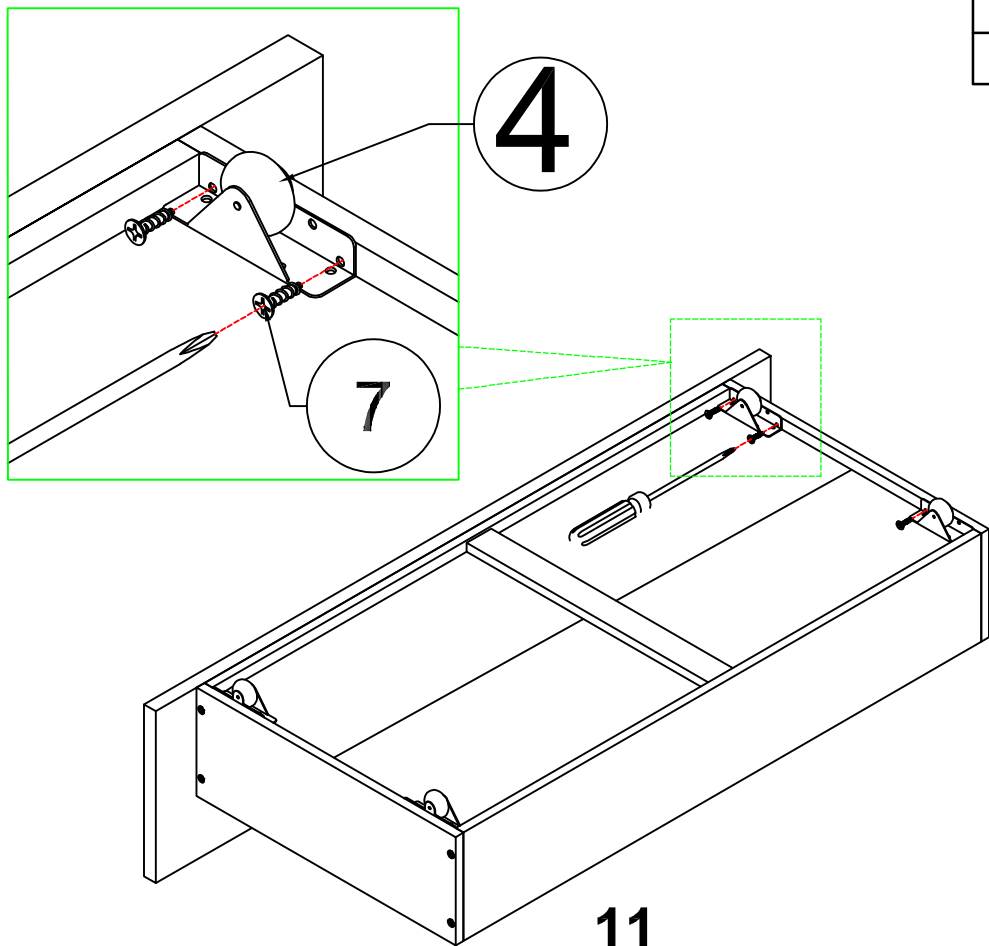

x2

11

# FINISH

