

Assembly Instruction

WF323167AAA

WF323168AAA

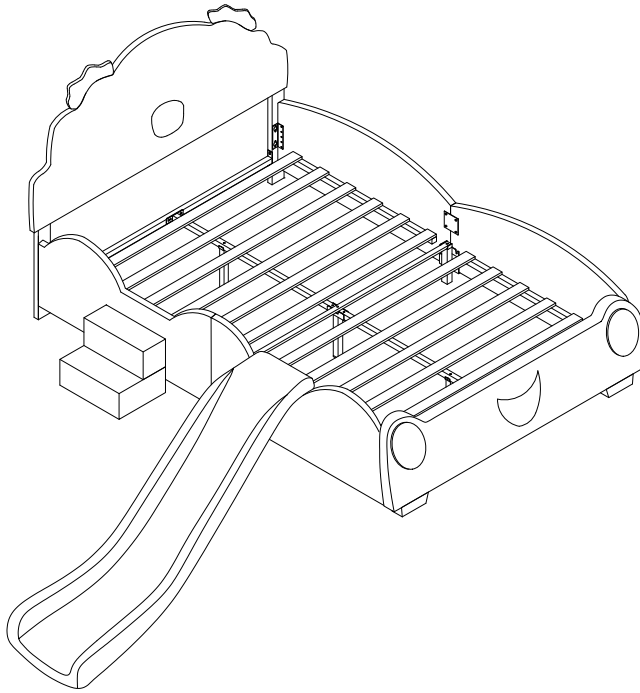

Please check that all parts are included before starting assembly. If you specify that something is missing, do not continue the assembly. Please contact us immediately.

Please read the complete instructions before installing this product. Please let at least two people participate in the assembly of this product!

Attention: Please do not tighten all screws before assembly is complete!

Detail View

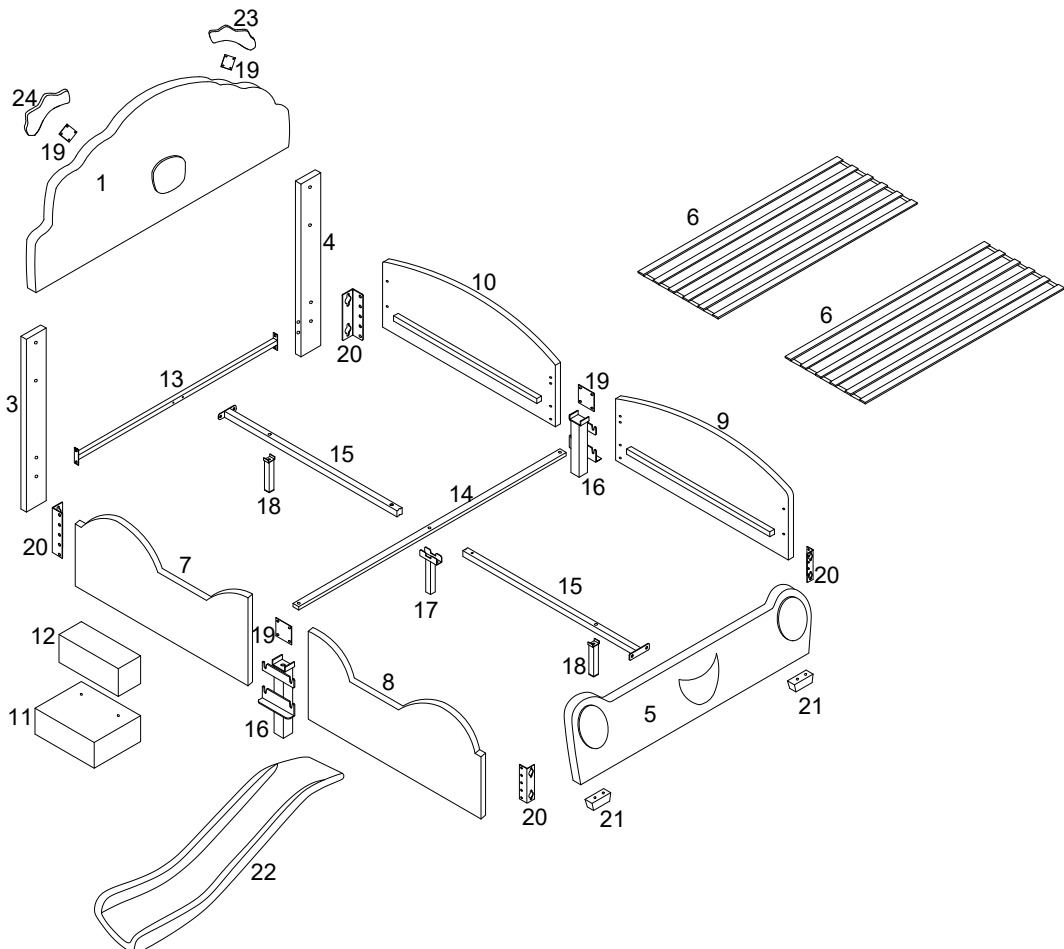

Assembly Instruction

WF323167AAA

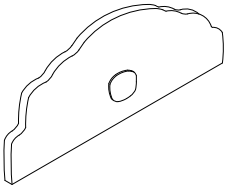

1. 1pc

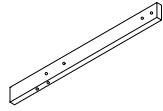

3. 1pc

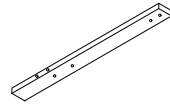

4. 1pc

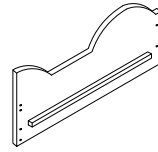

7. 1pc

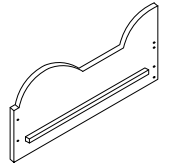

8. 1pc

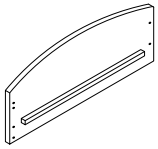

9. 1pc

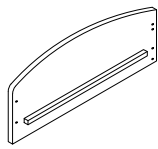

10. 1pc

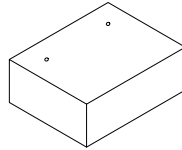

11. 1pc

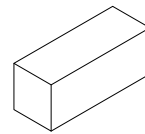

12. 1pc

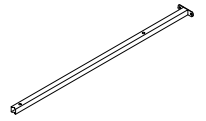

15. 2pc

WF323168AAA

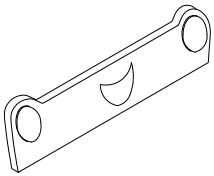

5. 1pc

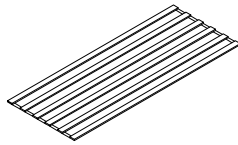

6. 2pcs

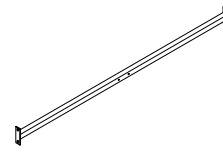

13. 1pc

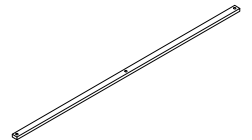

14. 1pc



16. 2pc

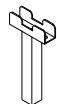

17. 1pcs



18. 2pc



19. 4pcs

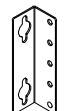

20. 4pcs



21. 2pcs

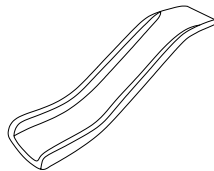

22. 1pc



23. 1pc



24. 1pc



M8*18
A. 48pcs



M8*40
B. 12pcs



M8*45
C. 1pc



M8
E. 1pc



M4*60
K. 4pcs



T. 4pcs

Assembly Instruction

Step:1

A x8pcs

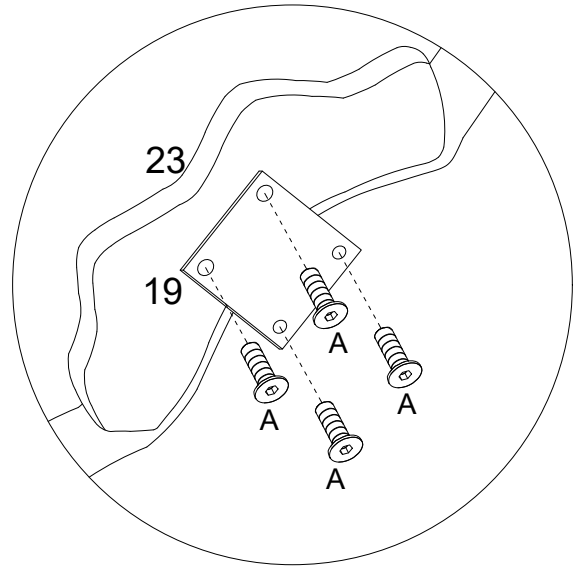
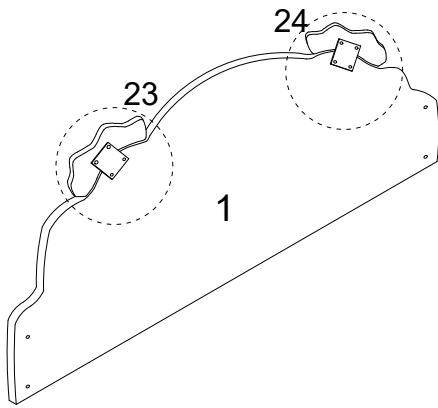

Step:2

B x4pcs
T x4pcs

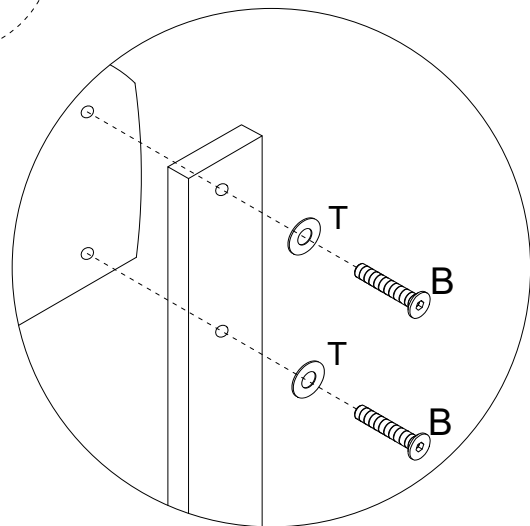
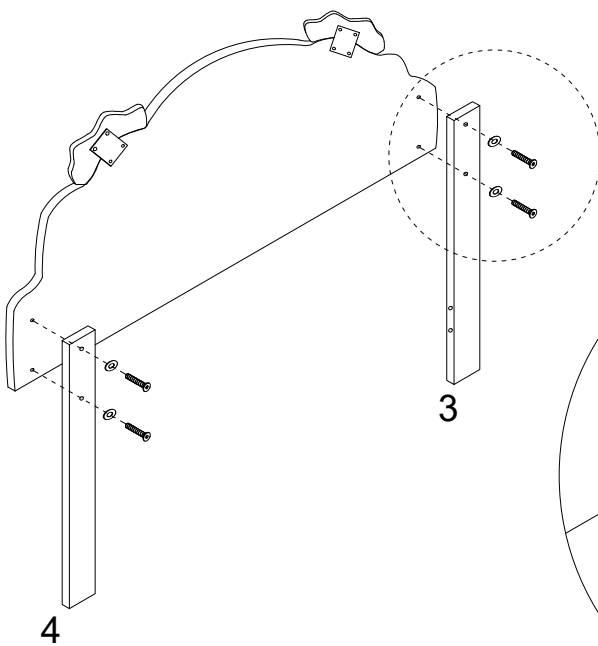

Assembly Instruction

Step:3

A x4pcs

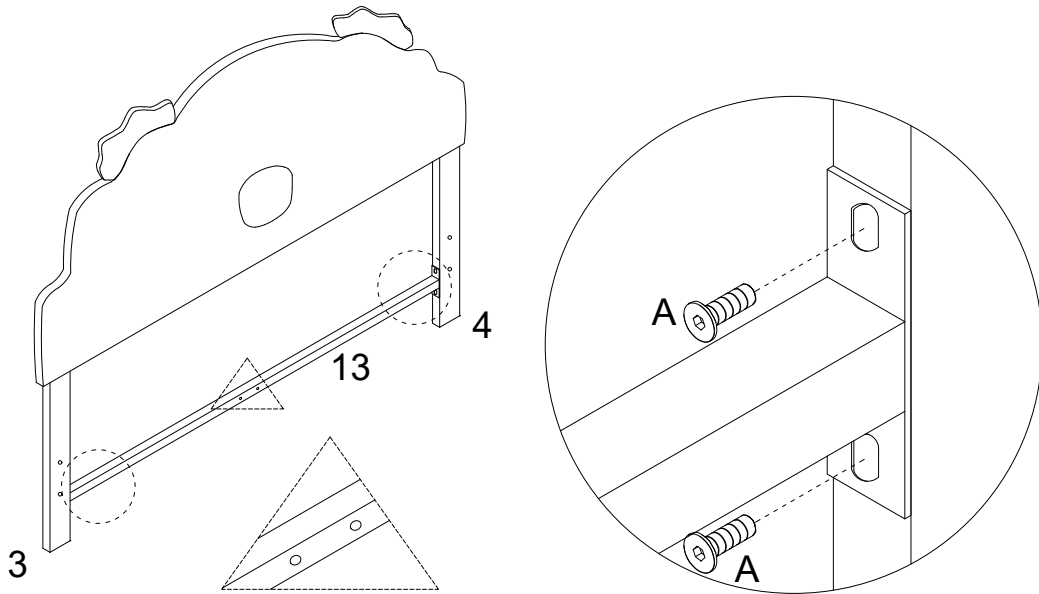

Step:4

A x16pcs

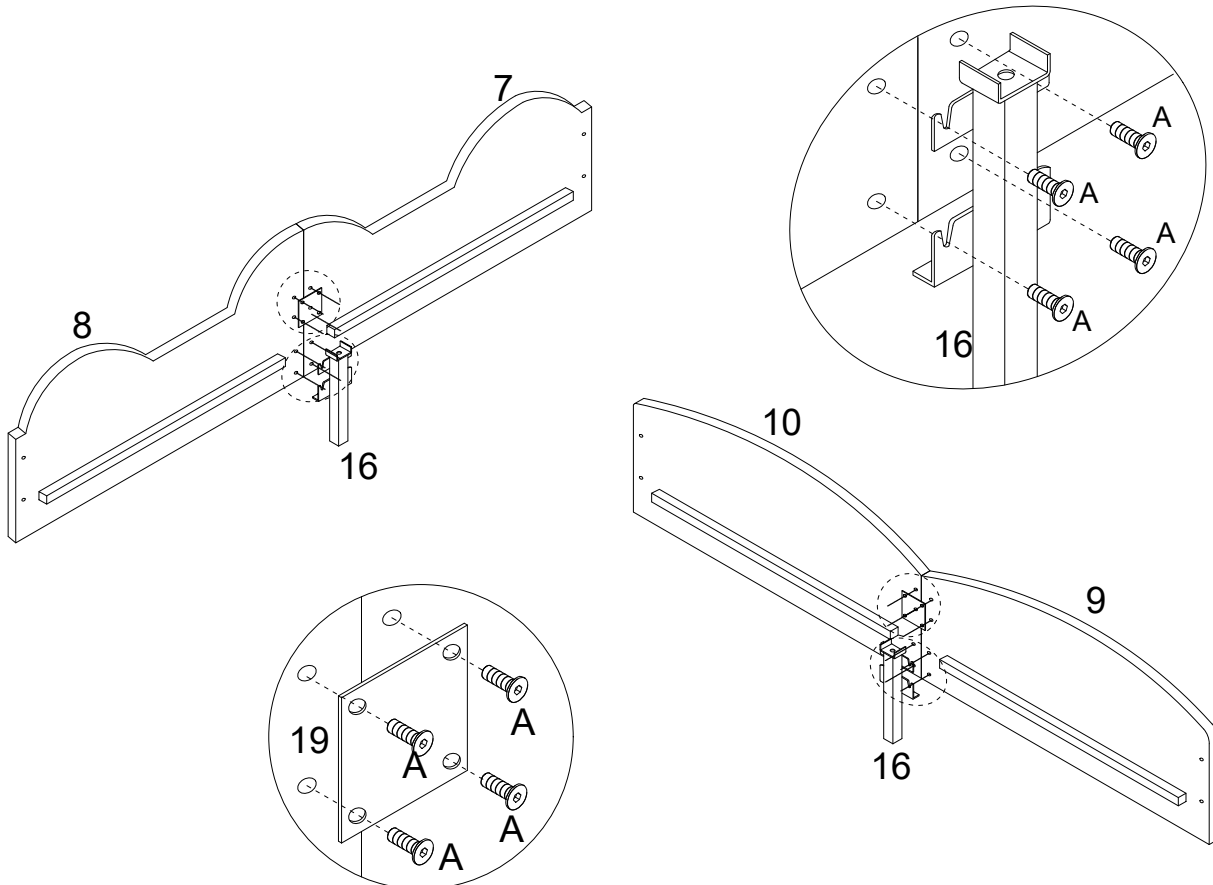

Assembly Instruction

Step:5

Ax8pcs

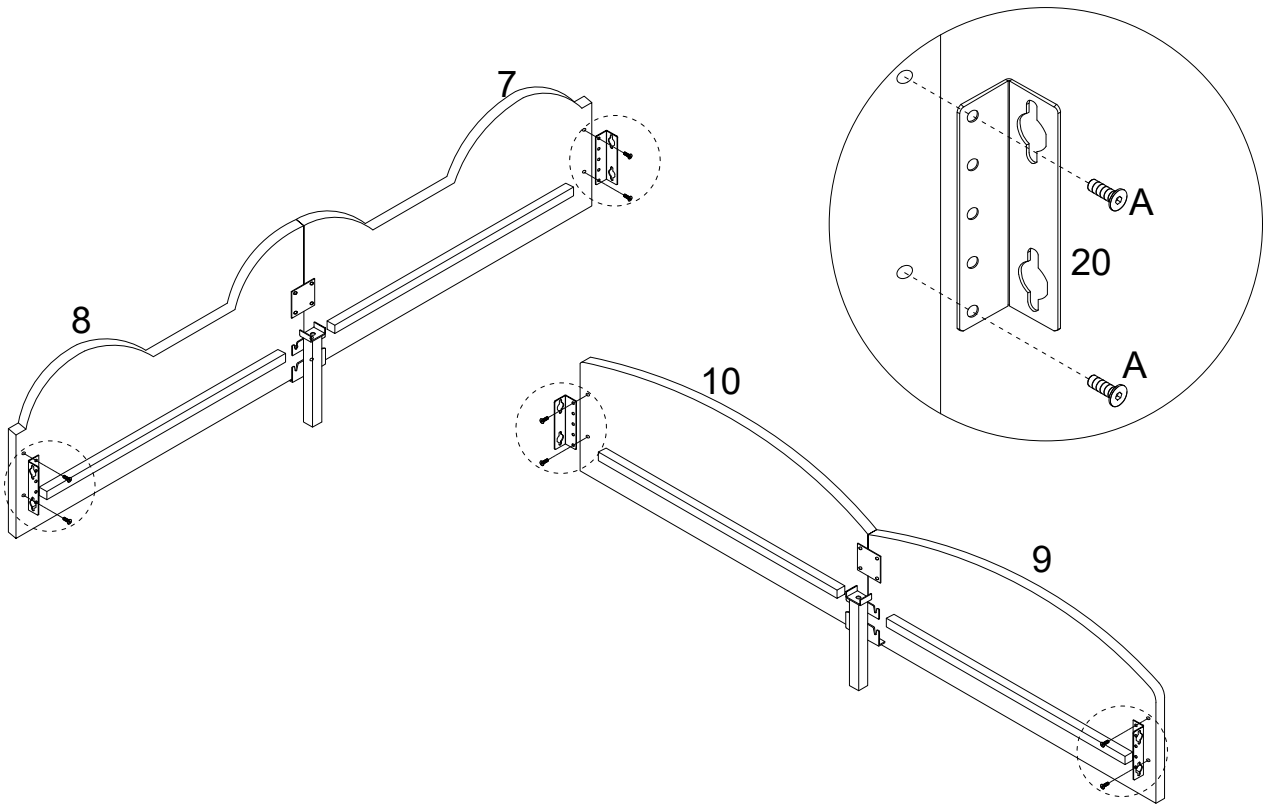

Step:6

Kx4pcs

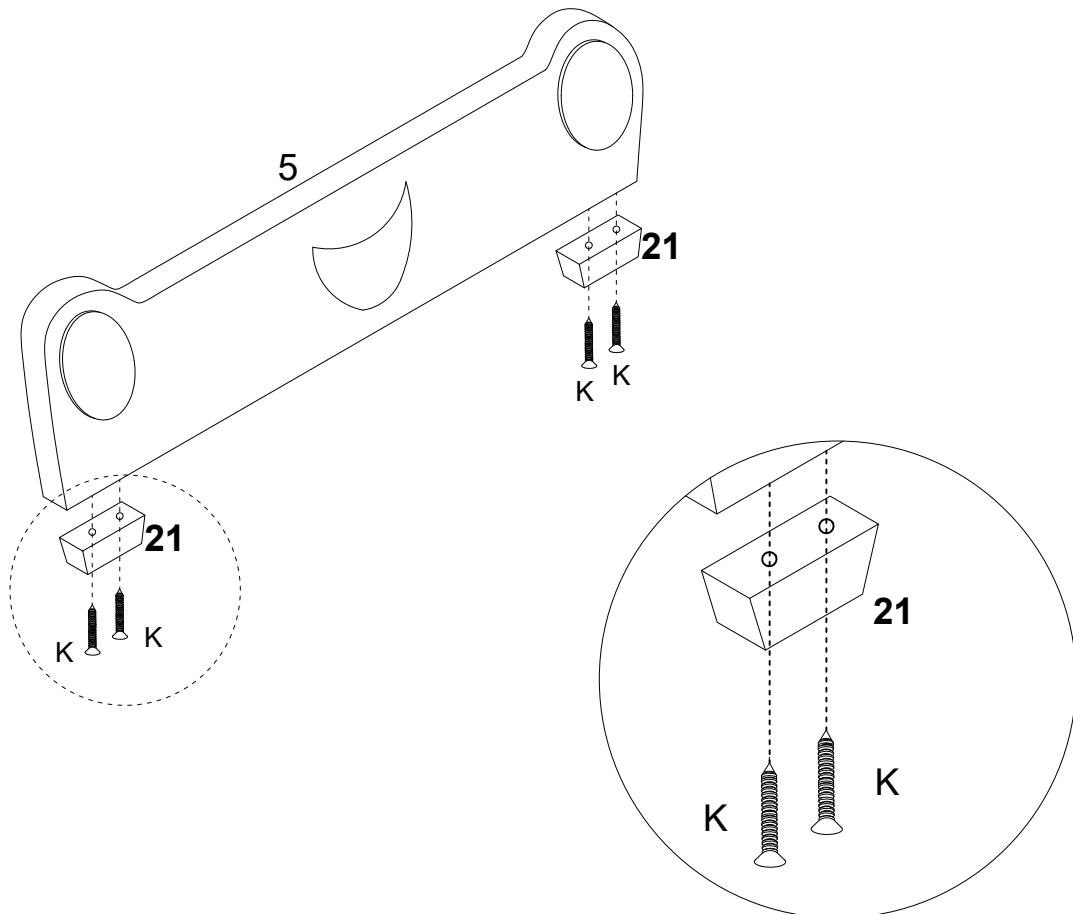

Assembly Instruction

Step:7

Ax8pcs

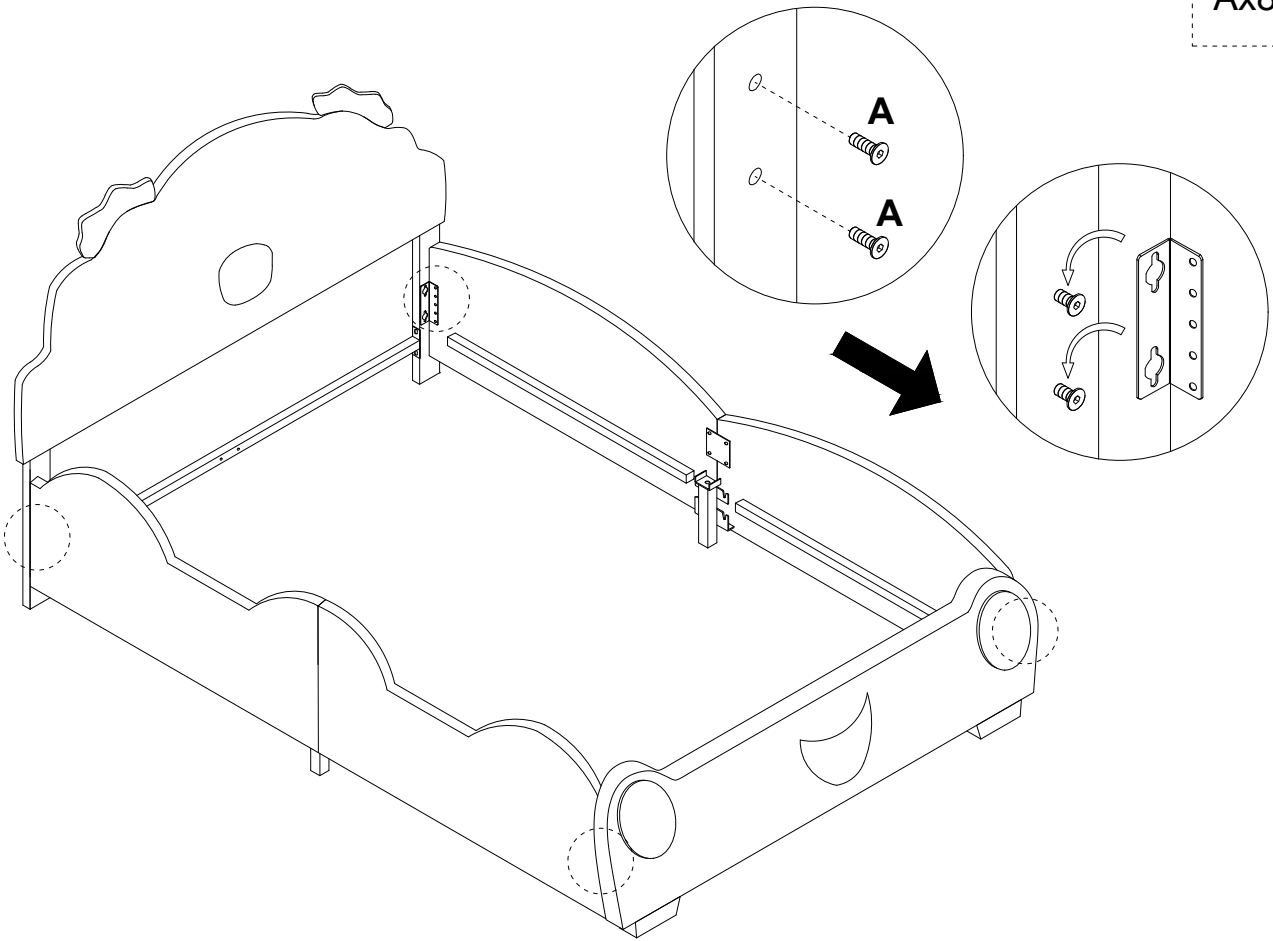

Step:8

Bx4pcs

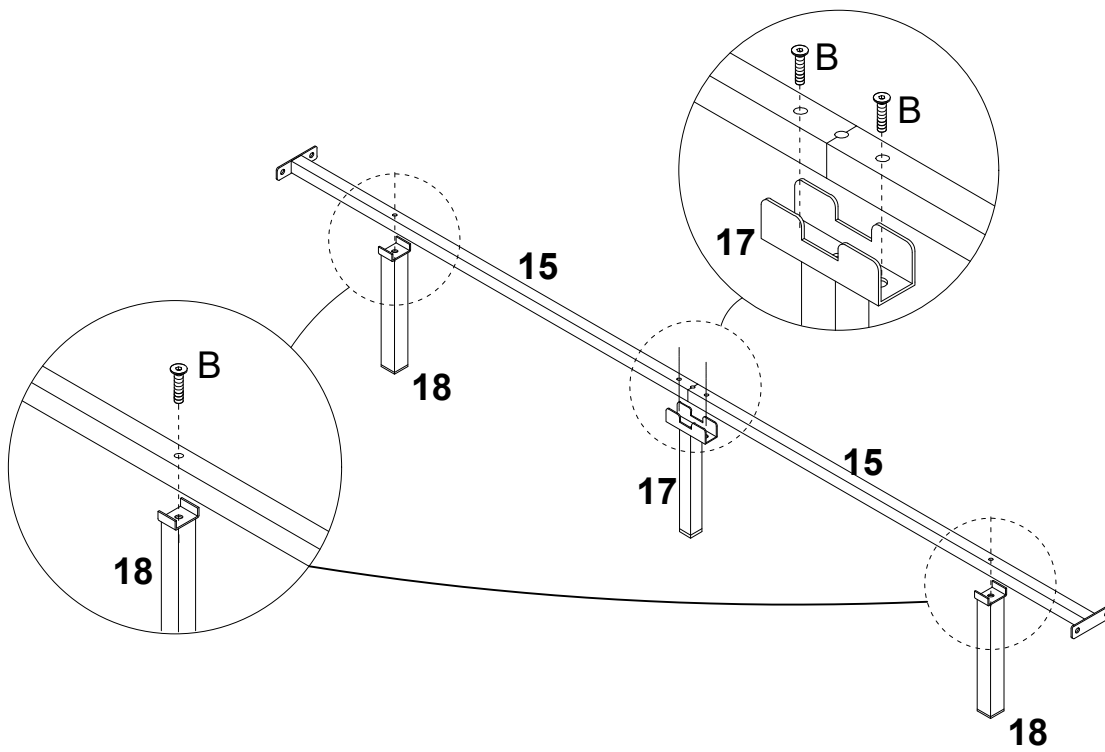

Assembly Instruction

Step:9

A x4pcs

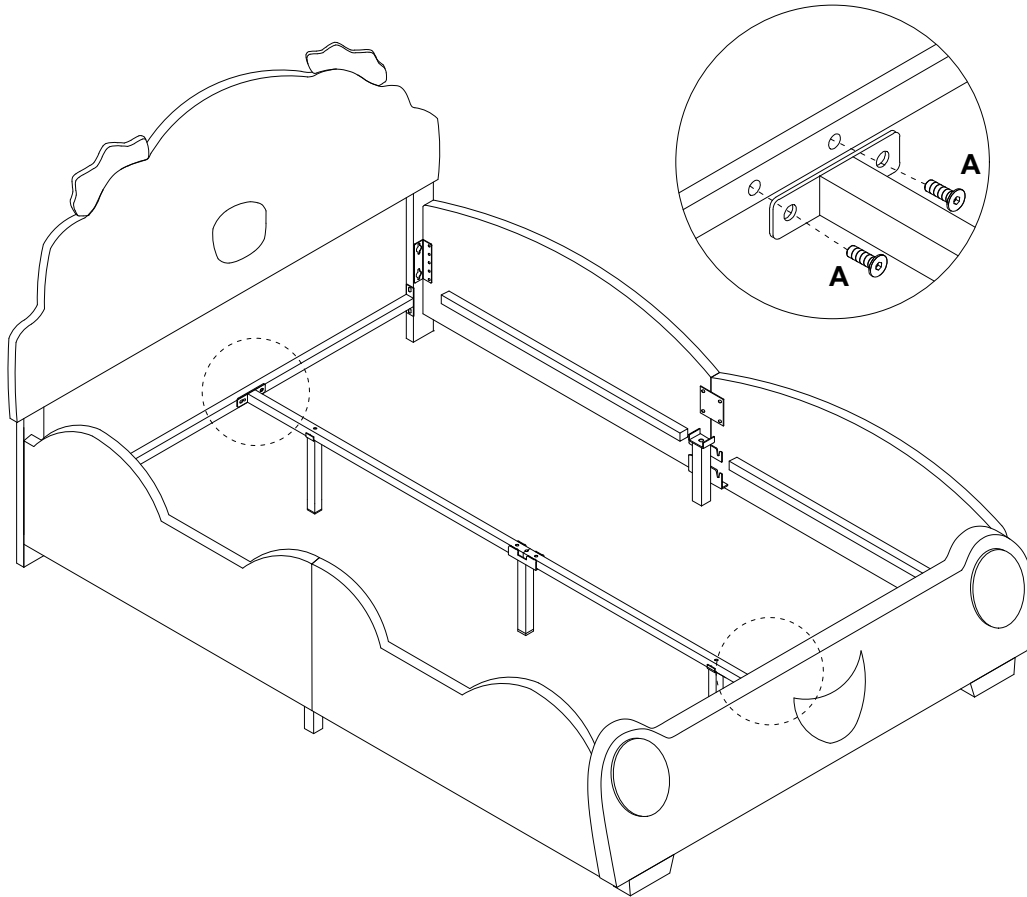

Step:10

B x2pcs
C x1pc

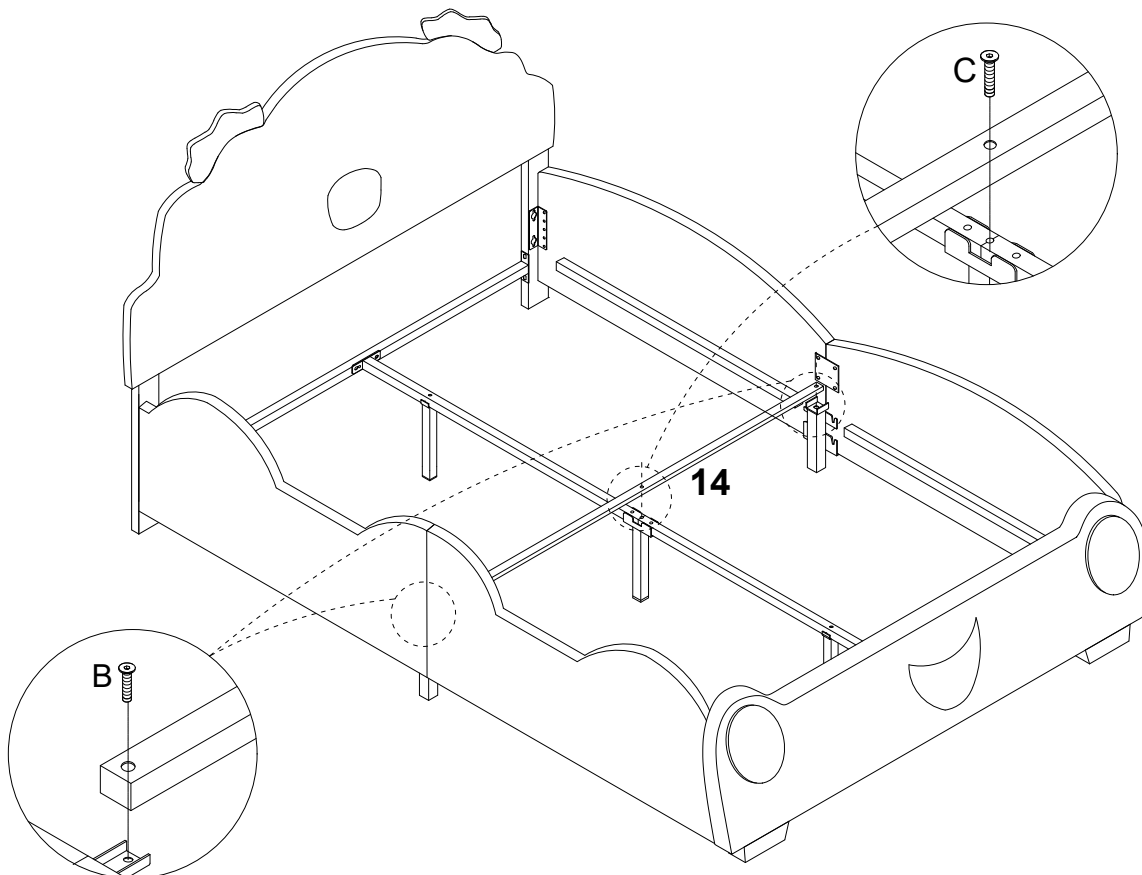

Assembly Instruction

Step:11

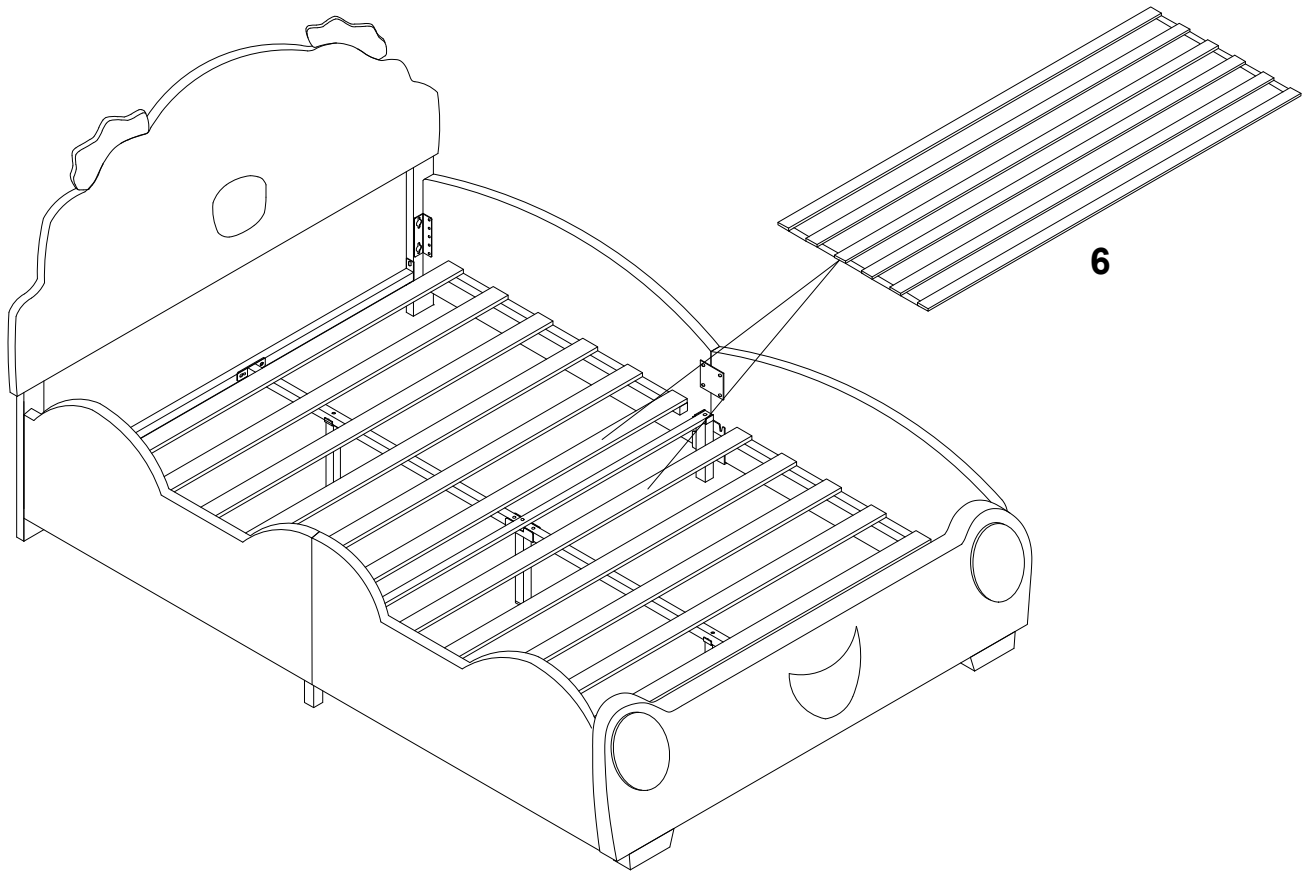

Step:12

B x2pcs

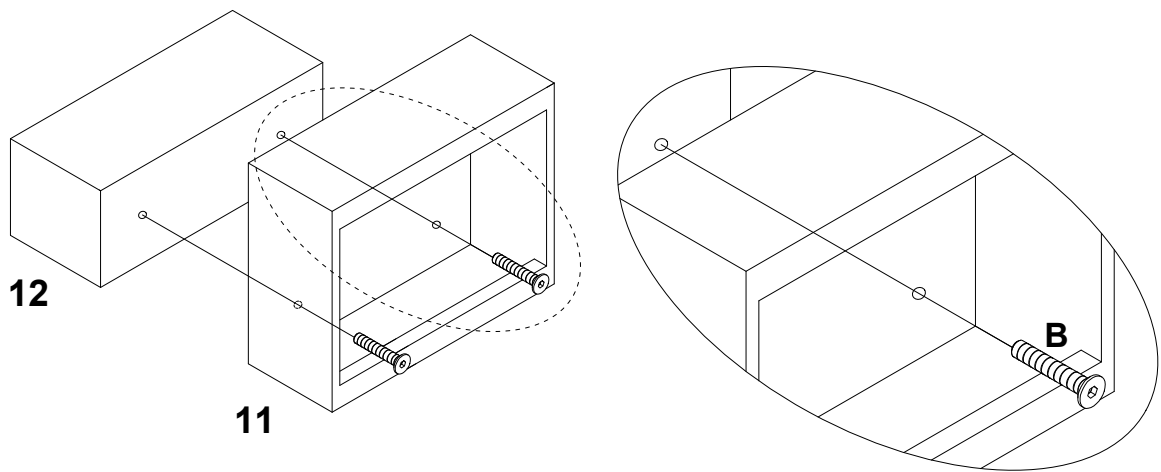

Assembly Instruction

Step:13

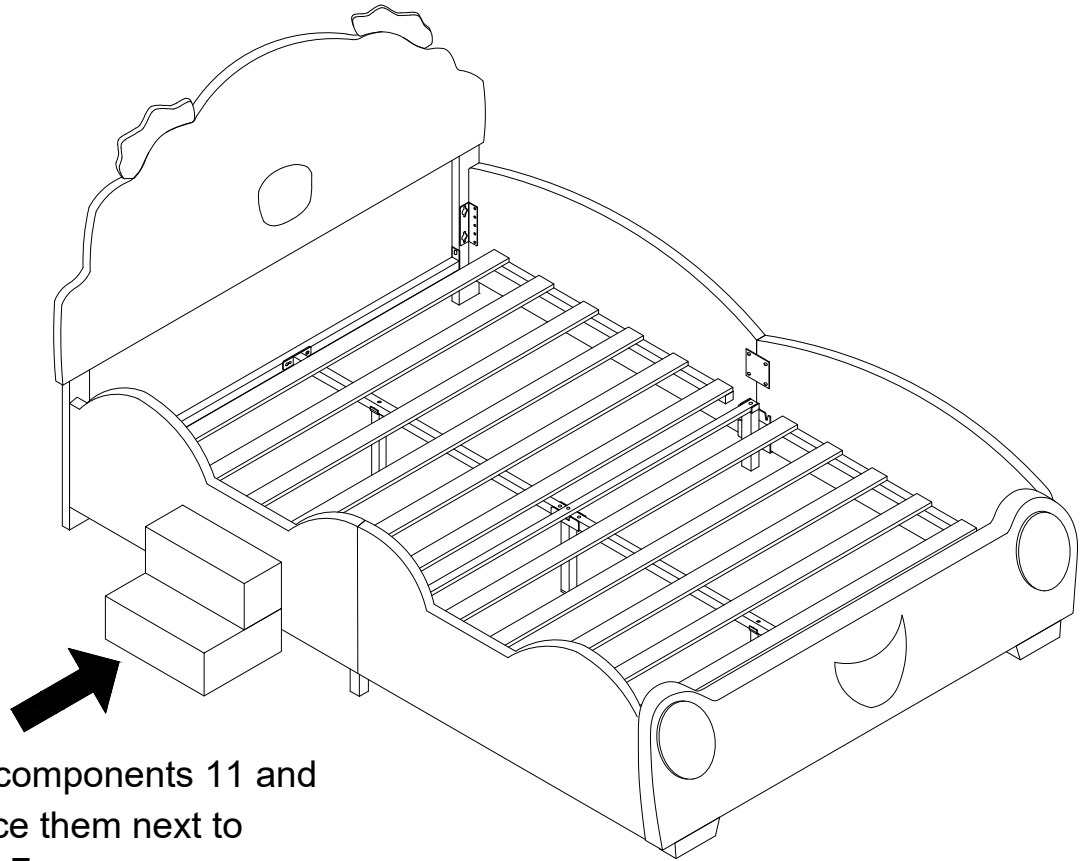

Assemble components 11 and 12 and place them next to component 7

Step:14

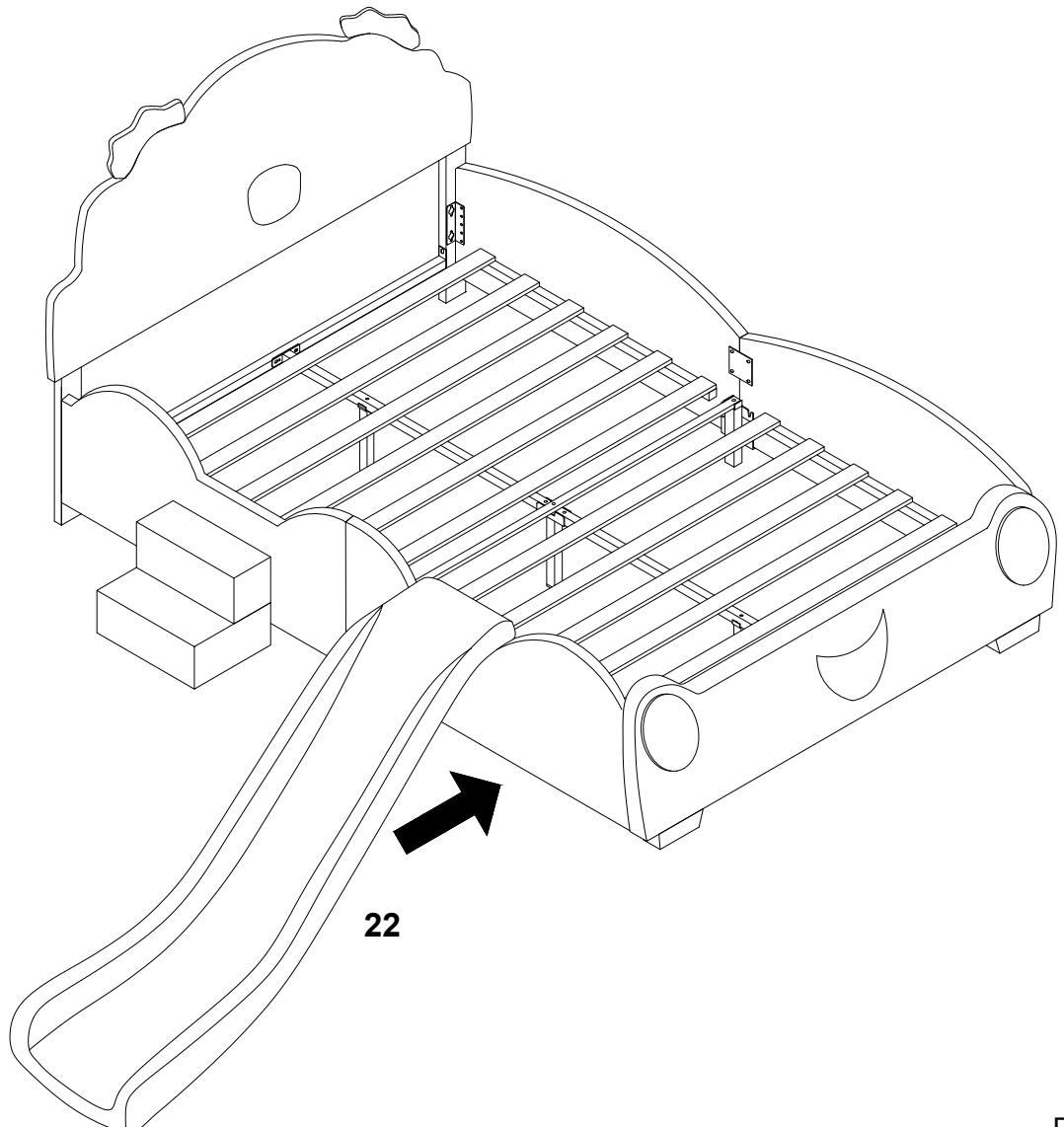

22