

# ASSEMBLY INSTRUCTION

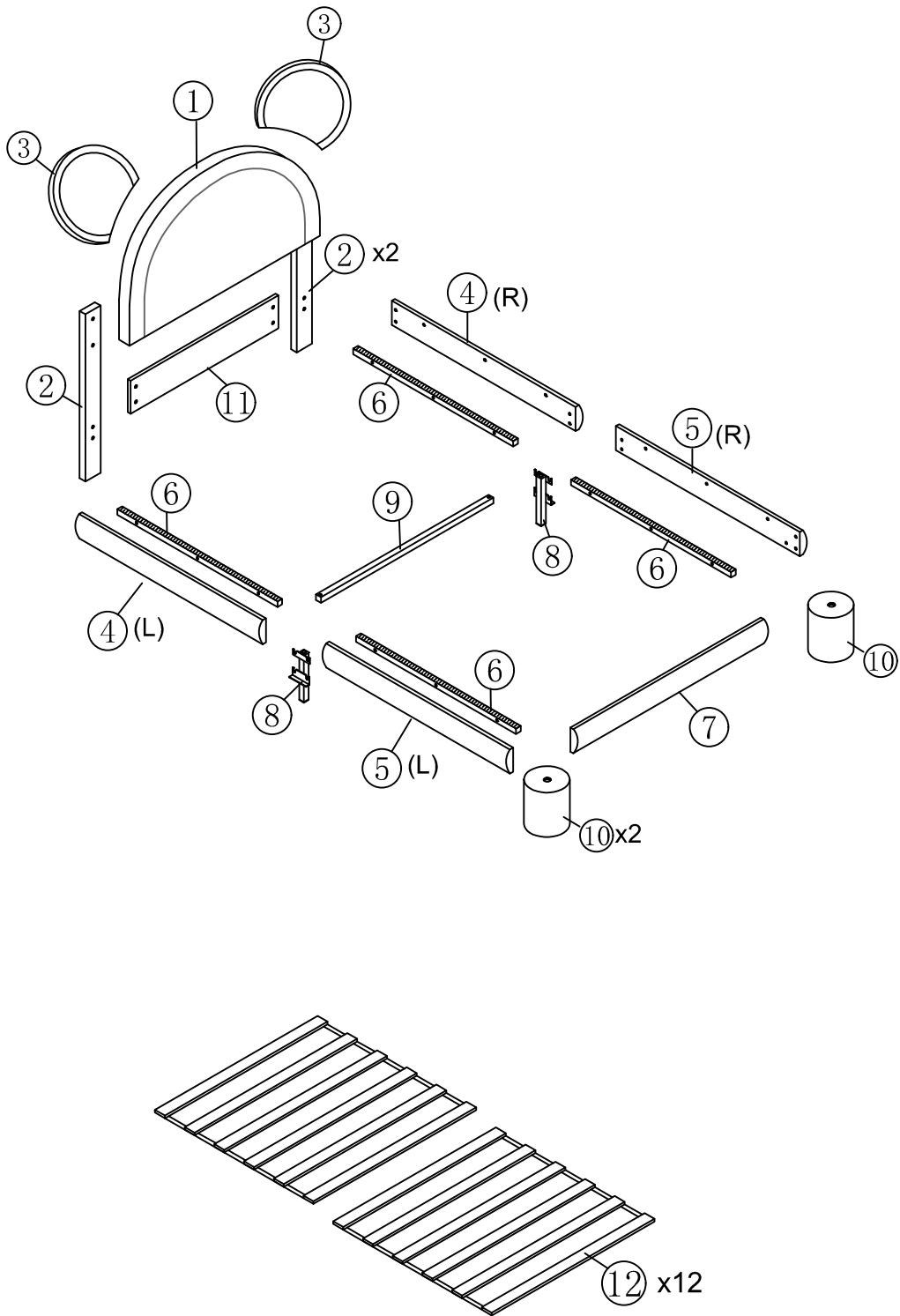







WF530084AAK

# Detail View

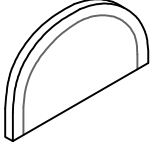

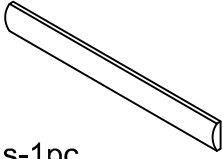
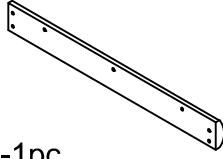
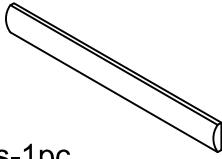
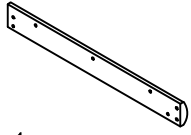
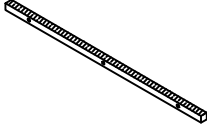
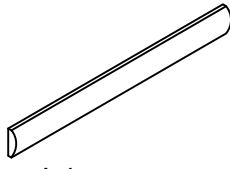

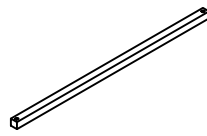

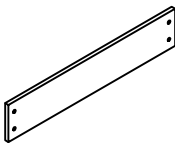
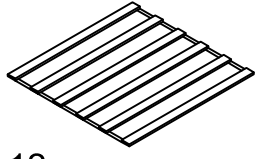







# Part List

WF530084AAK

<b>1</b>  Head board-1pc	<b>2</b>  Head board legs-2pcs	<b>3</b>  Ear of the Headboard-2pcs
<b>4L</b>  Siderails-1pc	<b>4R</b>  Siderails-1pc	<b>5L</b>  Siderails-1pc
<b>5R</b>  Siderails-1pc	<b>6</b>  Side rails support bar-4pcs	<b>7</b>  Foot board-1pc
<b>8</b>  Side rails support legs-2pcs	<b>9</b>  Cross bar-1pc	<b>10</b>  Bed legs-2pcs
<b>11</b>  Cross board-1pc	<b>12</b>  Slats-12pcs	

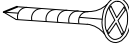

# Hardware List

## WF530084AAK

<b>A</b>  20*70mm	<b>B</b>  Ø8*45mm	<b>C</b>  Ø8*18mm
Allen Key(1pc)	Bolts(4pcs)	Bolts(54pcs)
<b>D</b>  Ø8*40mm	<b>E</b> 	<b>F</b>  77*33**33*3mm
Bolts(14pcs)	Four hole iron(6pcs)	"7" Connector(2pcs)
<b>G</b> 	<b>H</b> 	<b>I</b> 
Metal Corner(2pcs)	Little "7" Connector(2pcs)	Buckle(14pcs)
<b>J</b>  Ø3*16mm	<b>K</b> 	<b>L</b> 
Nails(28pcs)	Color controller(1pc)	Power adapter(1pc)
<b>M</b> 		
LED(1pc)		



Remark: We recommend you assemble your bed in the flat ground.

### Step 1

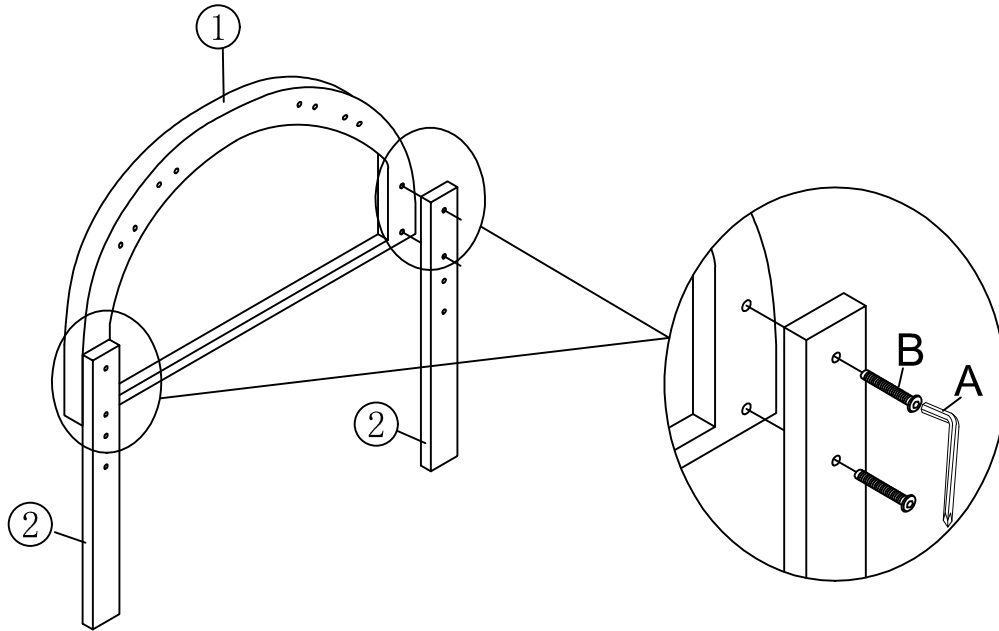
A		B	 M8X45mm
		4PCS	



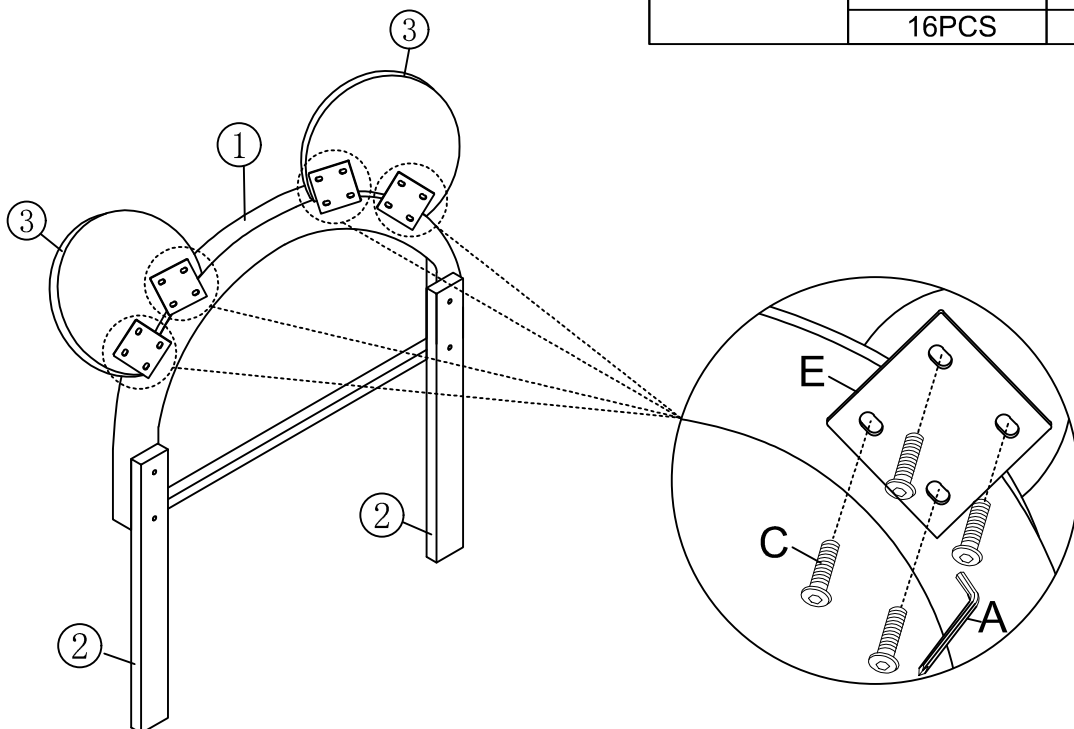

### Step 2

A		C	 M8X18mm	E	
		16PCS		4PCS	



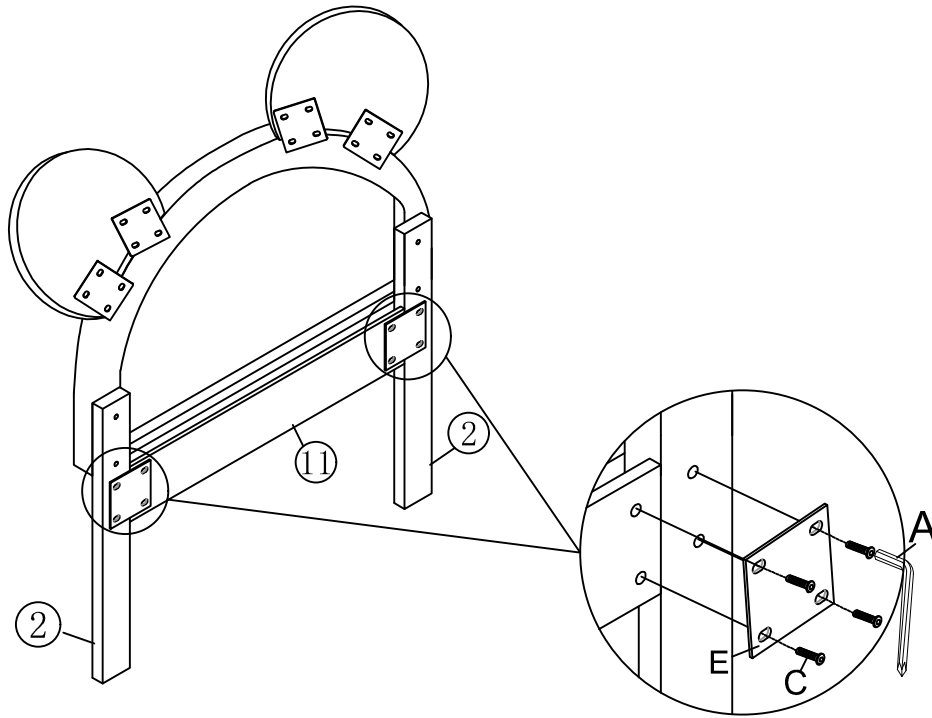

# Step 3

<p>A</p> 	<p>C</p>  <p>M8X18mm</p> <p>8PCS</p>	<p>E</p>  <p>2PCS</p>
---	---	--



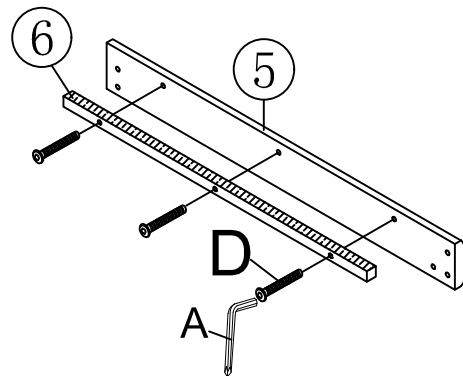
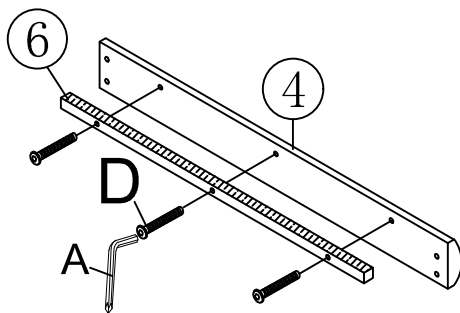

# Step 4 x2

<p>A</p> 	<p>D</p>  <p>12PCS</p>
--	---



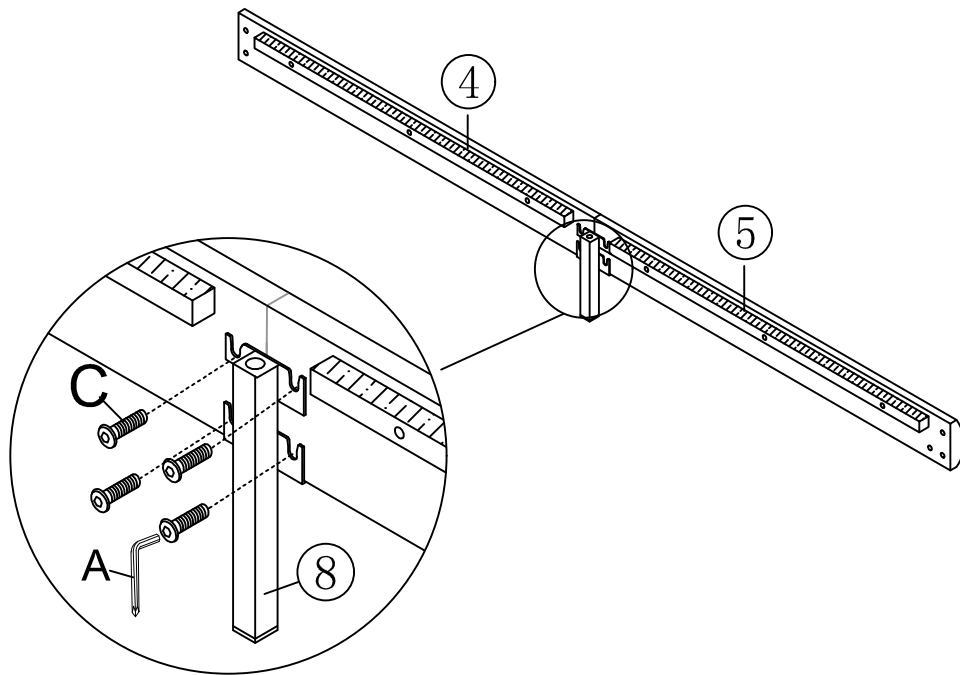

# Step 5 x2

<p>A</p> 	<p>C</p>  <p>M8X18mm</p> <hr/> <p>8PCS</p>
--	---





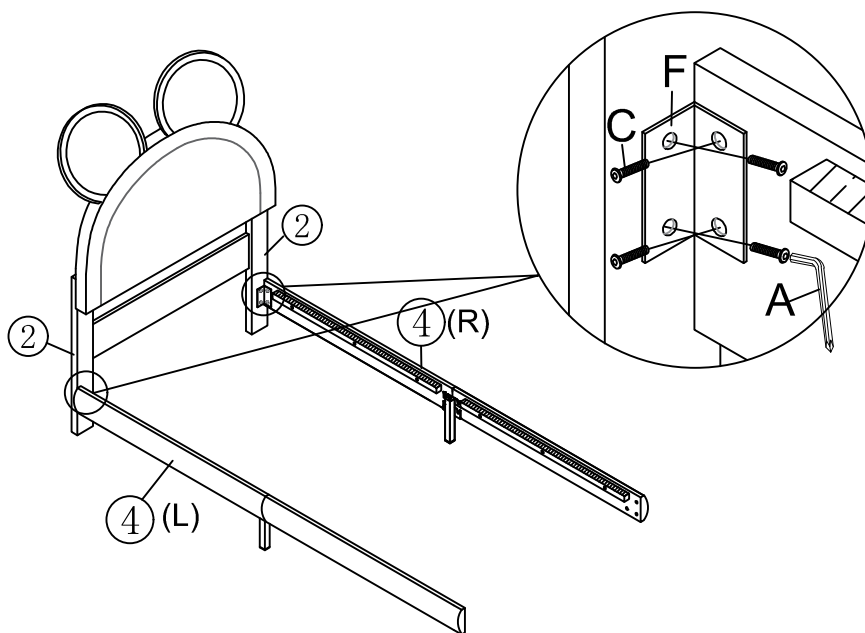

# Step 6

<p>A</p> 	<p>C</p>  <p>M8X18mm</p> <hr/> <p>8PCS</p>	<p>F</p>  <hr/> <p>2PCS</p>
---	---	--



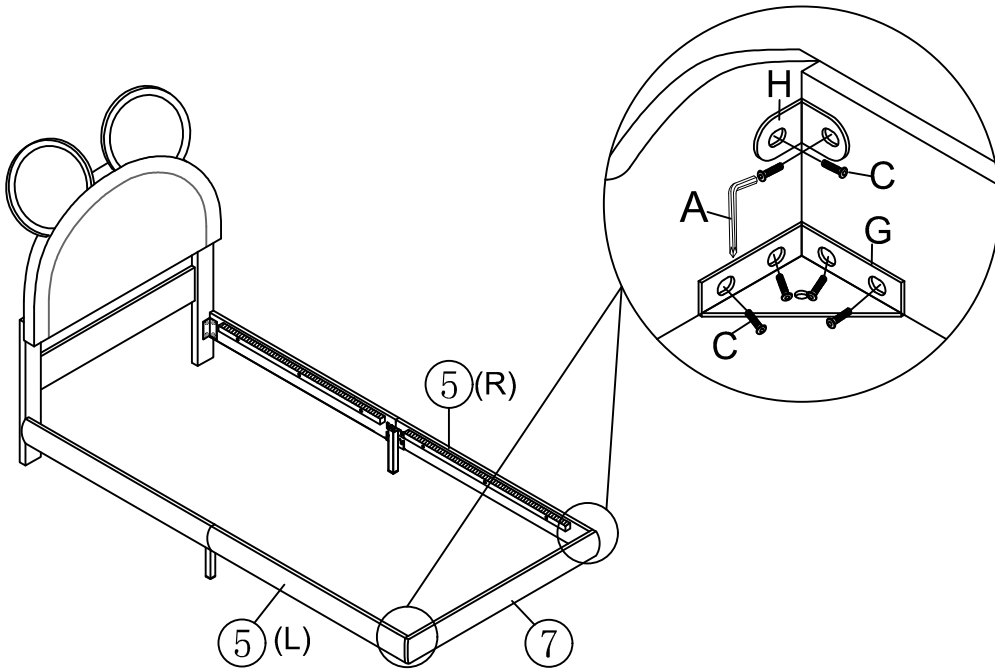

# Step 7

<p>A</p> 	<p>C</p>  <p>M8X18mm</p> <p>12PCS</p>	<p>G</p>  <p>2PCS</p>	<p>H</p>  <p>2PCS</p>
--	---	--	--



# Step 8

<p>A</p> 	<p>C</p>  <p>M8X18mm</p> <p>2PCS</p>
--	---

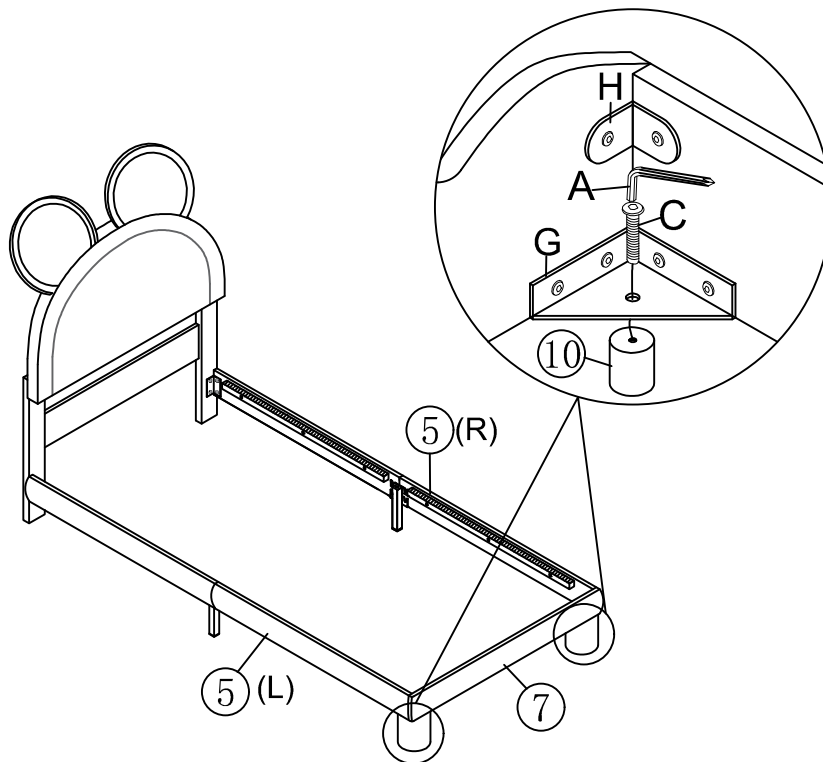



# Step 9

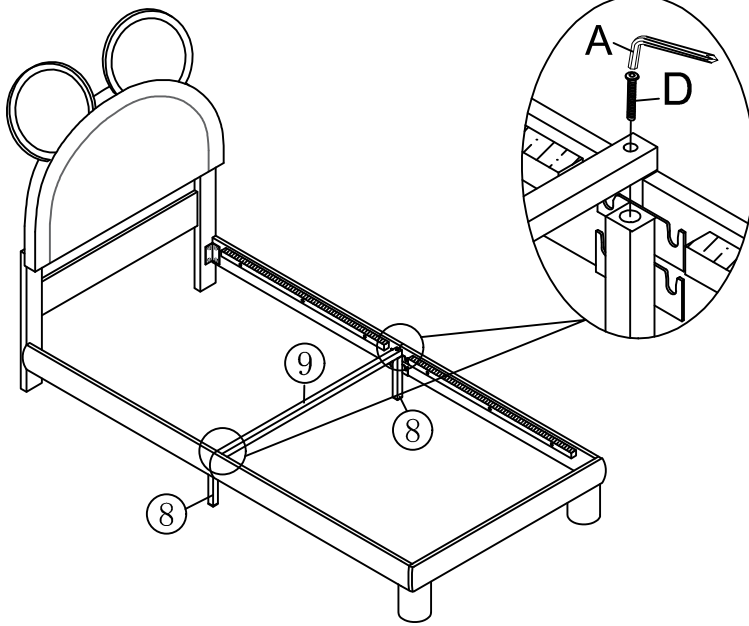

A		D	 M8X40mm
		2PCS	

# Step 10

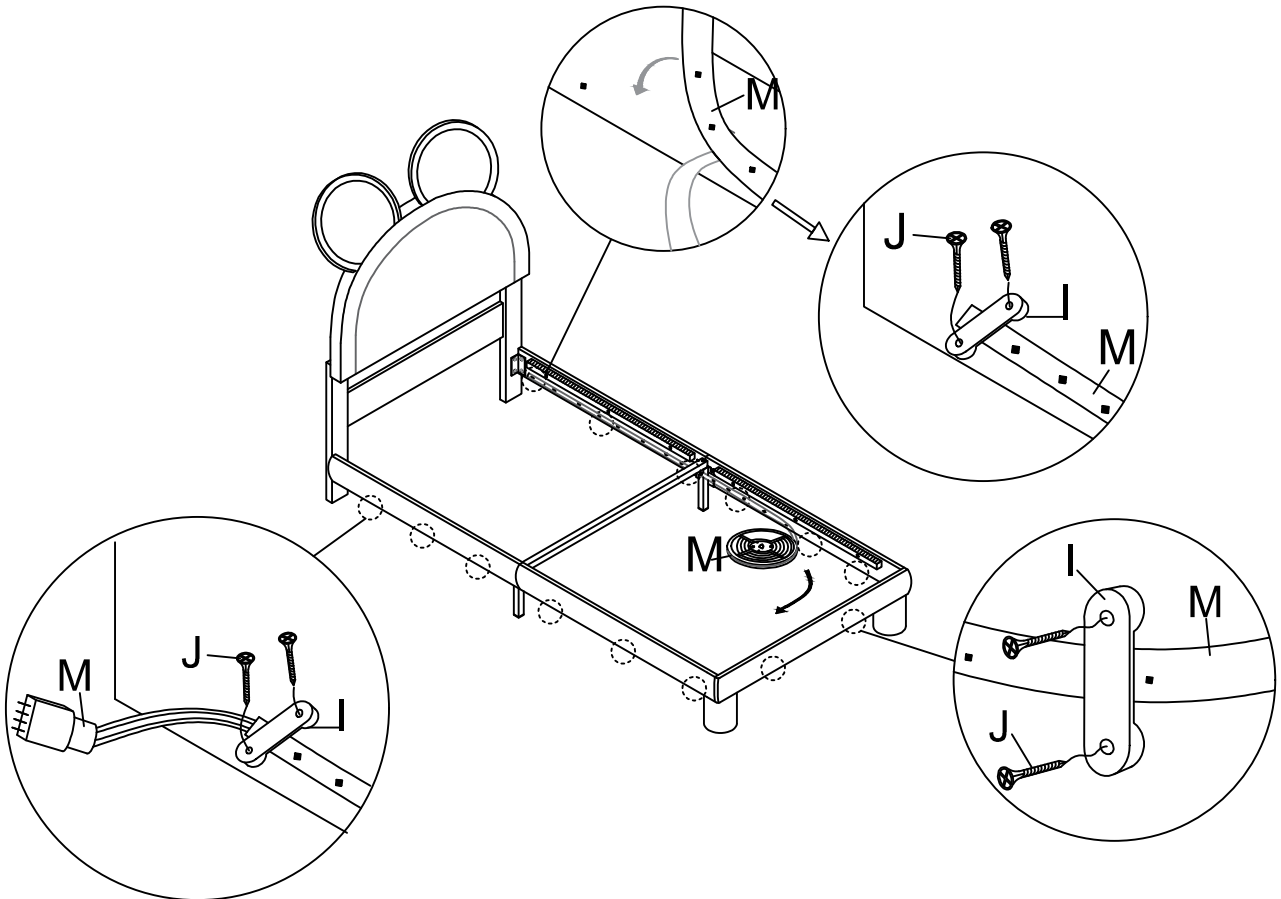

A		I		J	 M3X16mm	M	
		14PCS		28PCS		1PC	

# Step 11

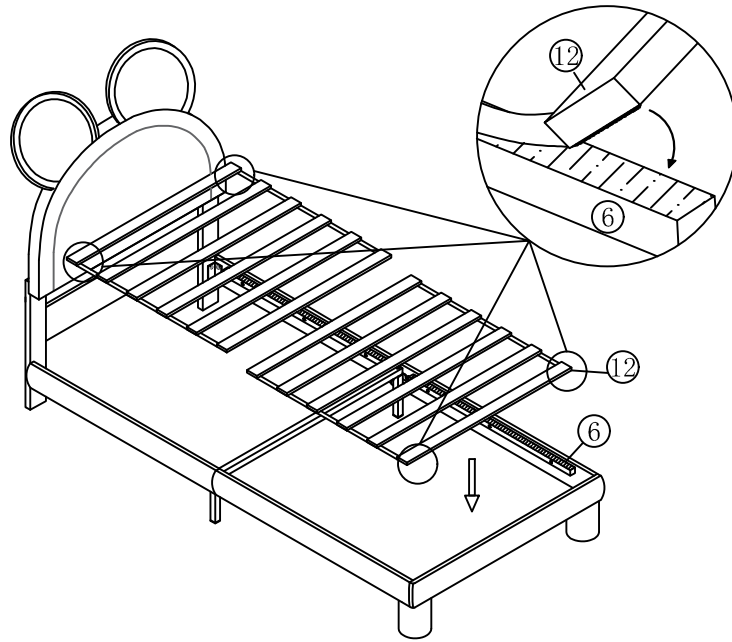

# Step 12

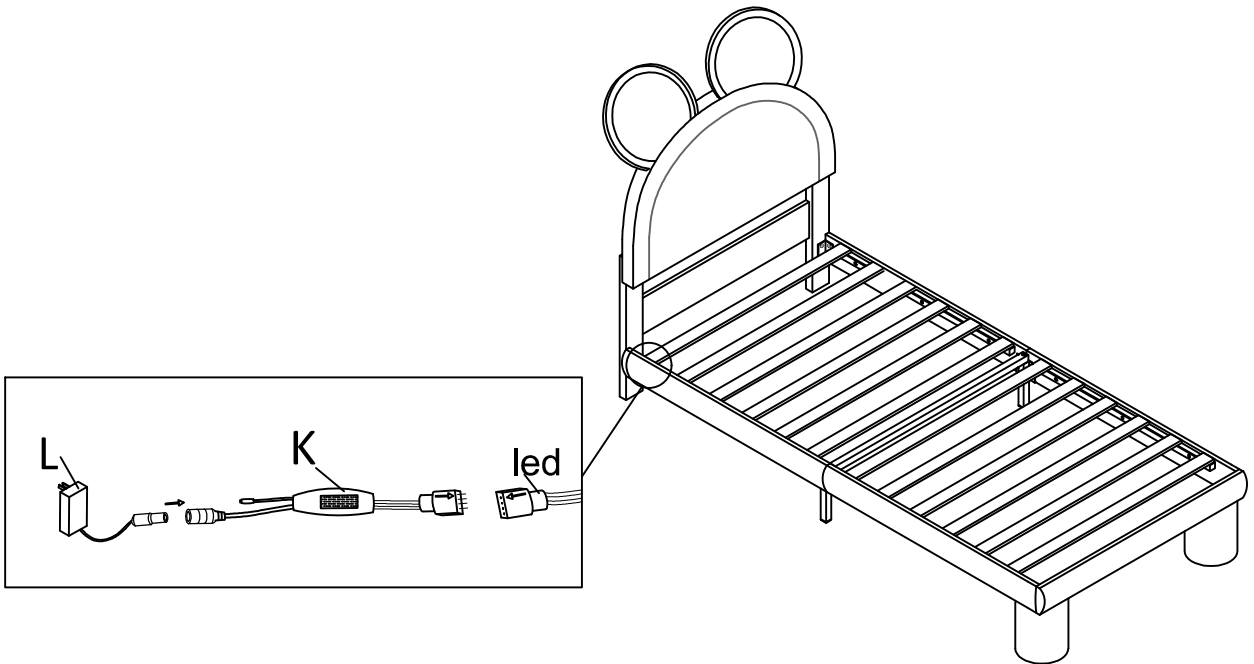
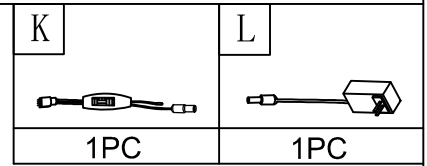

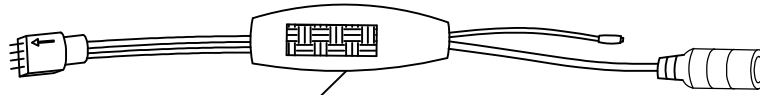

**NOTICE:**

You can scan the QR code here and download an app that can control the color of the light strip like a remote control. When your phone plays music through the app, the color of the light strip will also change according to the strength of the music.

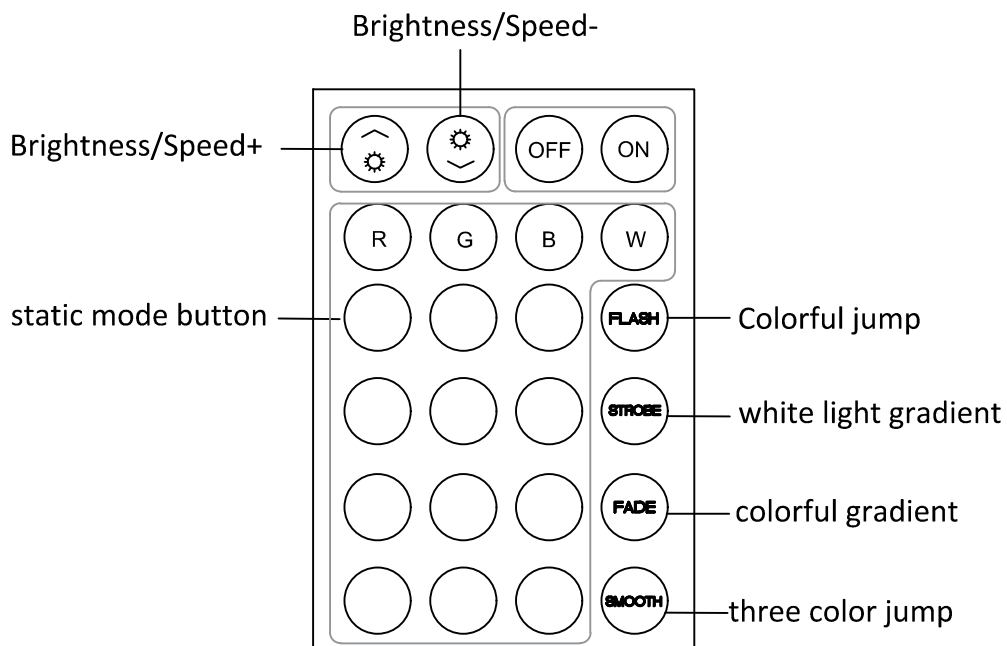

**NOTICE:**

When you use the remote control board to control the color of the light, Please remove the clear plastic card first, then please be sure to point the remote control at the color controller K.