

# ASSEMBLY INSTRUCTION

SKU CODE: (WF323634/WF323635)

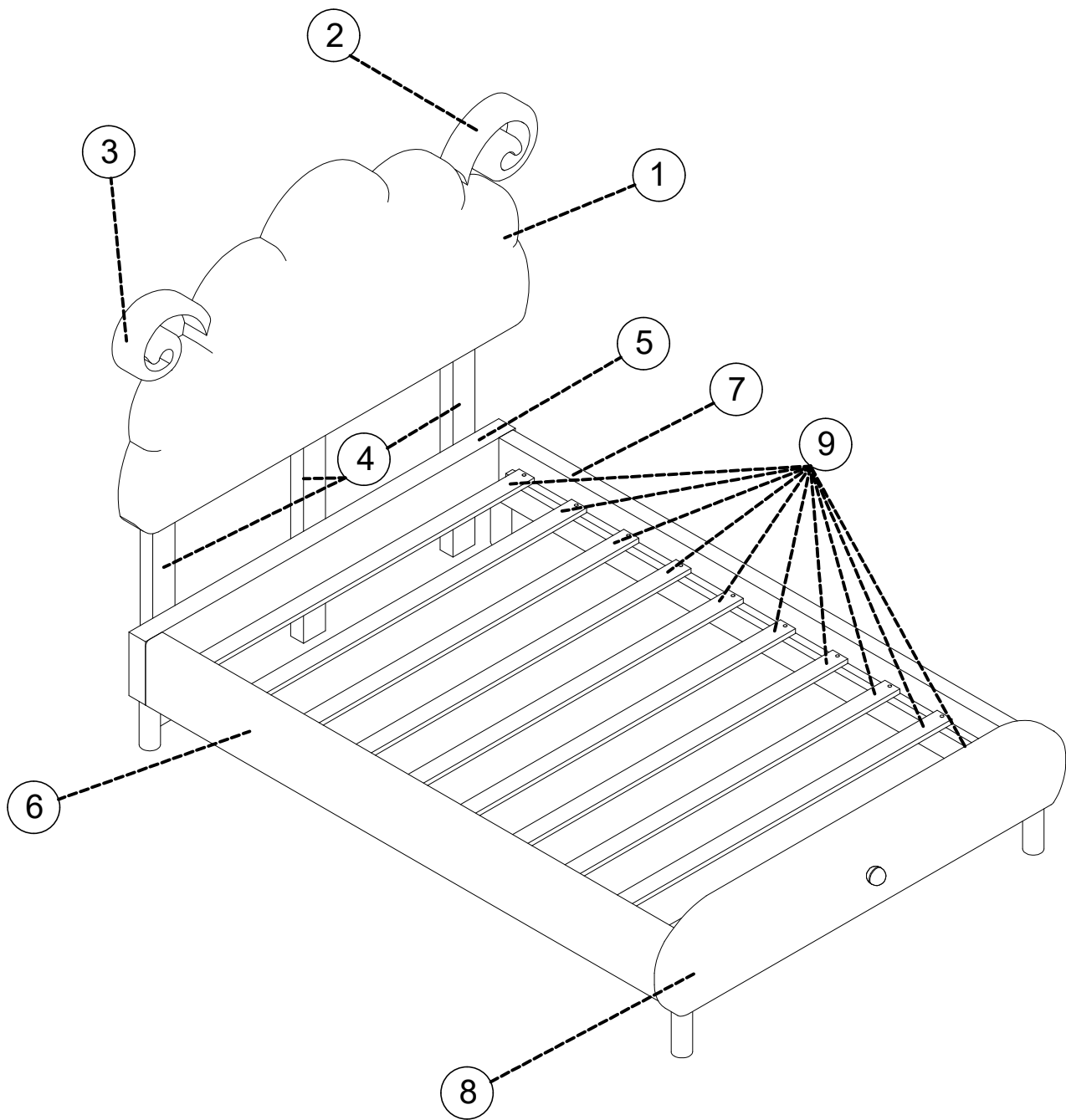



This set included 2 boxex if do not receive full 2 boxex. Please contact our customer service team



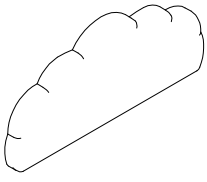
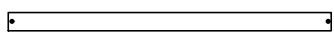

# Part List

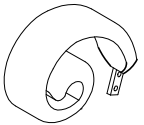
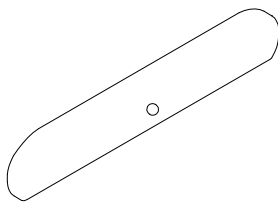
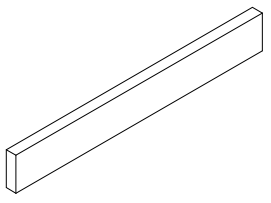
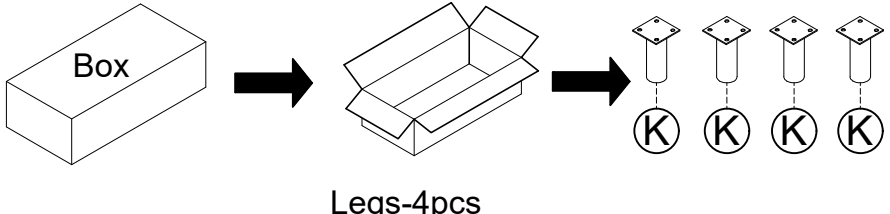
BOX 1/2: **WF323634**

1  Head board -1pc	9  Slates-10pcs	2  Wing board Right-1pc
3  Wing board Left-1pc	8  Footboard-1pc	5  Head board below-1pc
K  Box → Legs-4pcs → Hardware		Hardware 



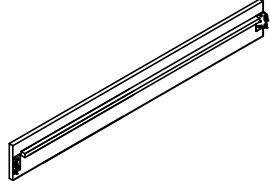
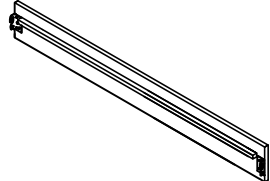
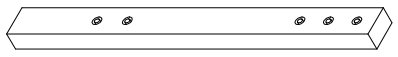





BOX 2/2: **WF323635**

6  Side rail Left - 1pc	7  Side rail Right - 1pc	4  Head board legs -3pcs
--	---	---



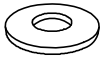

# HARDWARE

Check that you've received  
all hardware listed below.

## Hardware List



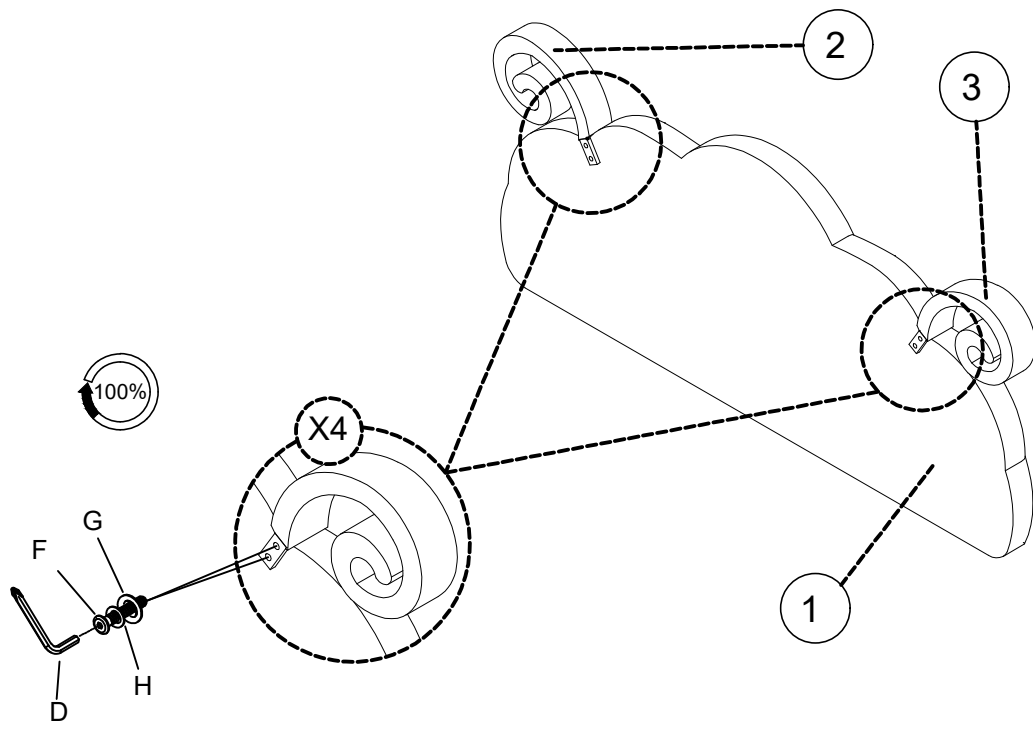

No.	OUTLOOK	DESC	QTY
(A)		Bolts 5/16"x30 mm	8
(B)		Plain washer Ø5/16"x19x1.5 mm	23
(C)		Spring washer Ø5/16"x12 mm	23
(D)		Allen key 80x30x4 mm	1
(E)		Bolts 5/16"x45 mm	15
(F)		Bolts 1/4"x30 mm	12
(G)		Plain washer Ø1/4"x19x1.5 mm	16
(H)		Spring washer Ø1/4"x10 mm	12
(I)		Screws Ø4x30 mm	24

# STEP 1

F x 4	G x 4	H x 4	D x 1
			





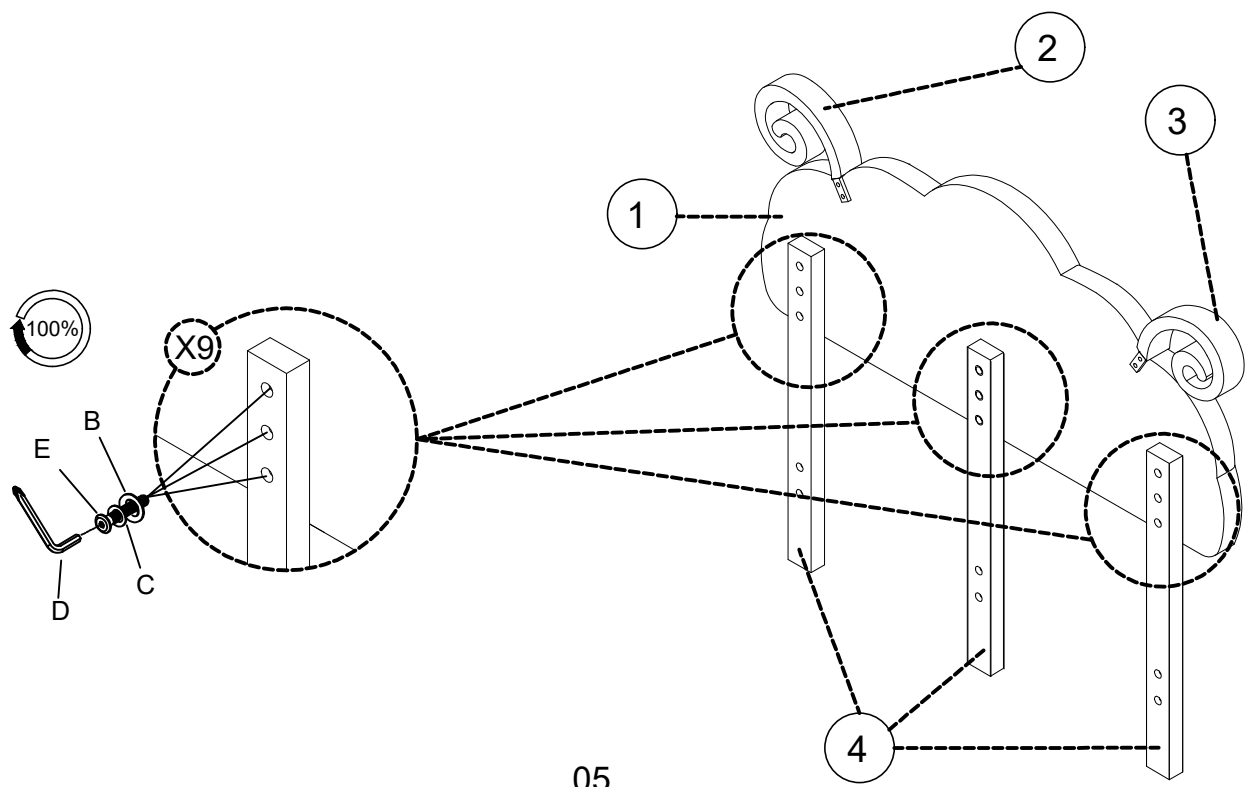

# STEP 2

E x 9	B x 9	C x 9	D x 1
			





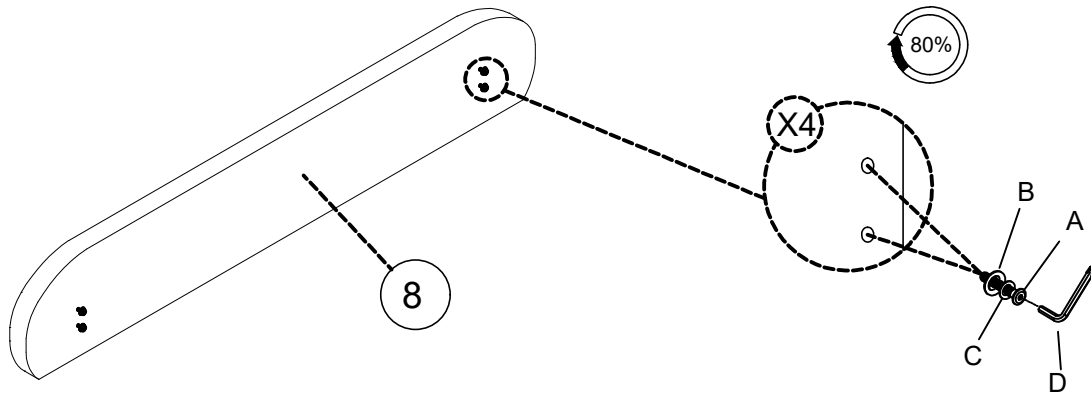

# STEP 3

A x 4	B x 4	C x 4	D x 1
			



# STEP 4

A x 4	B x 4	C x 4	D x 1
			

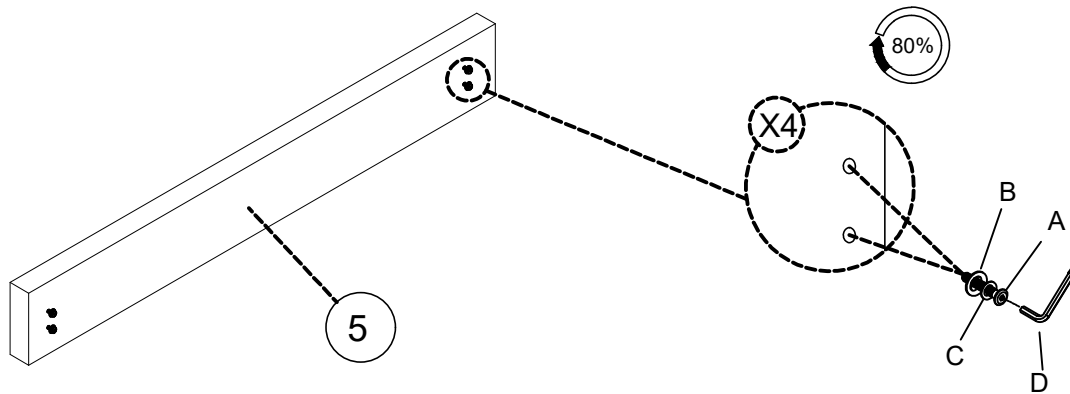



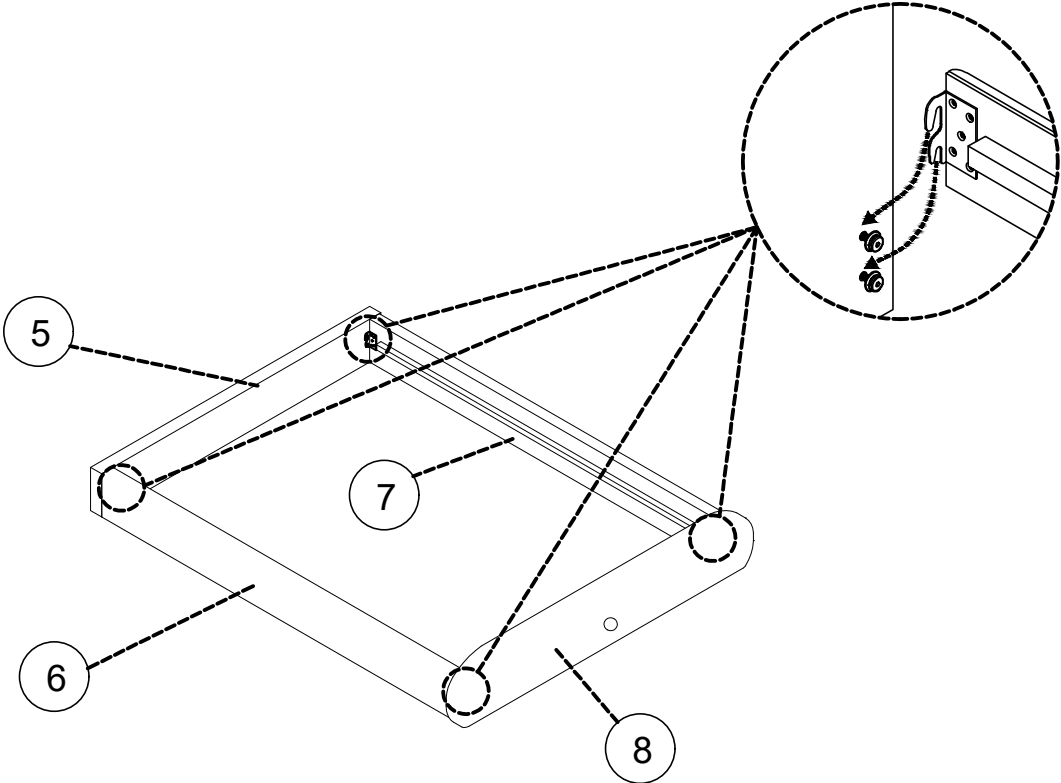

# STEP 5

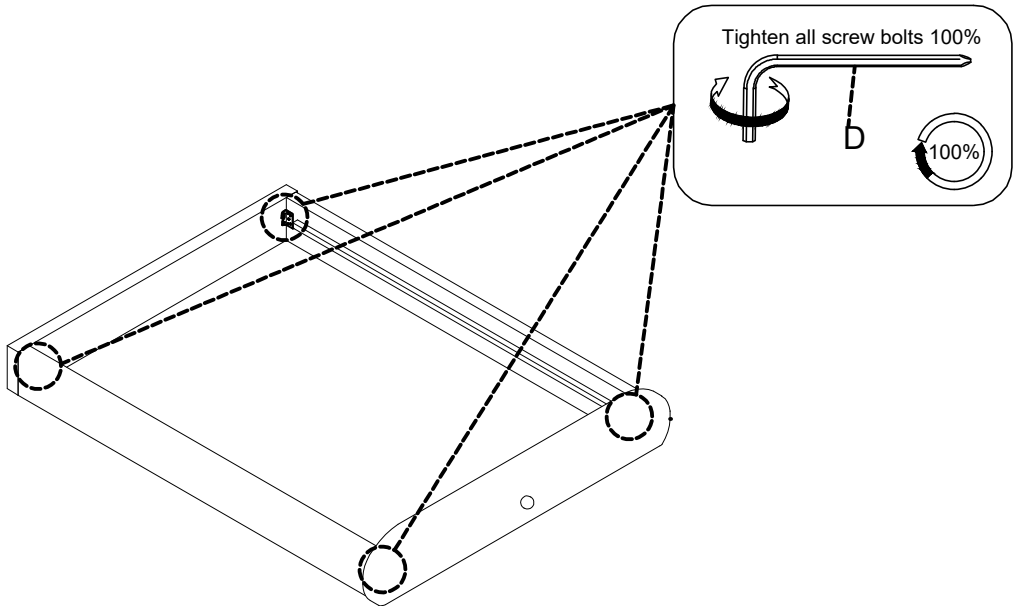

# STEP 6





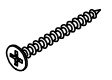

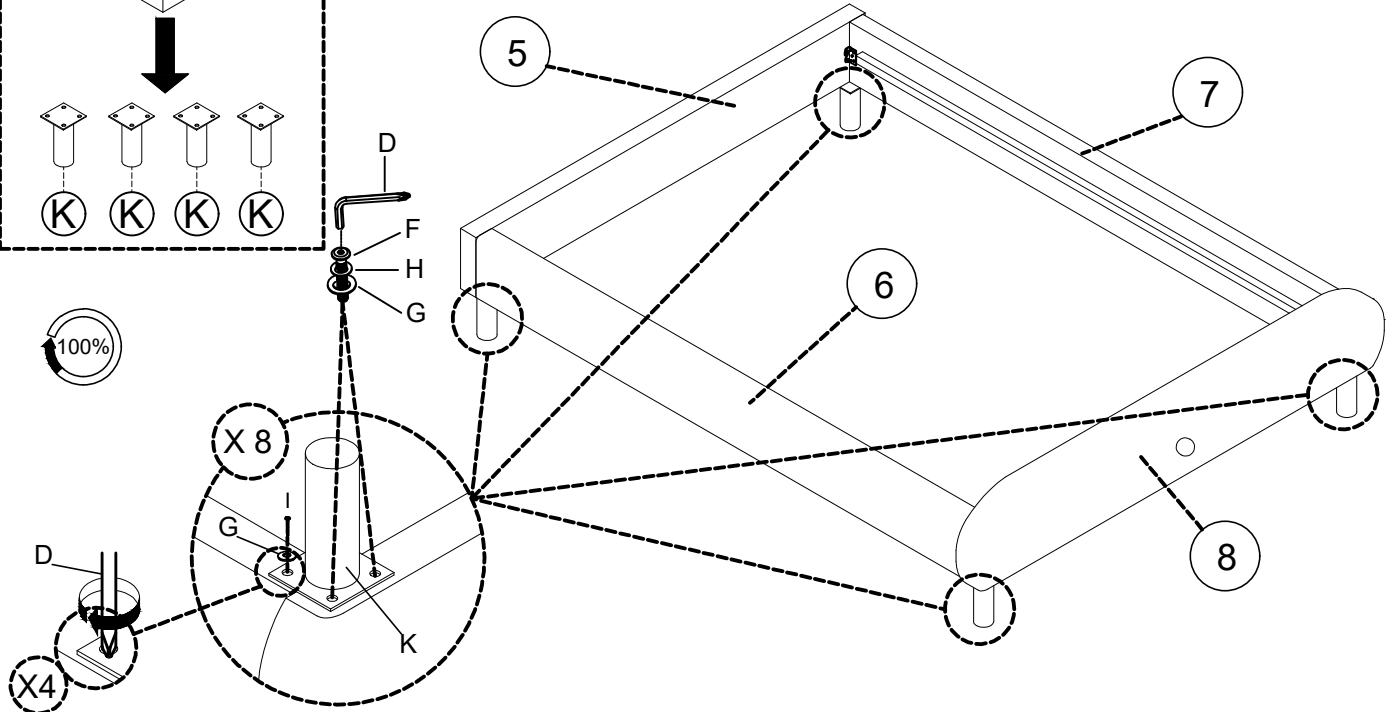
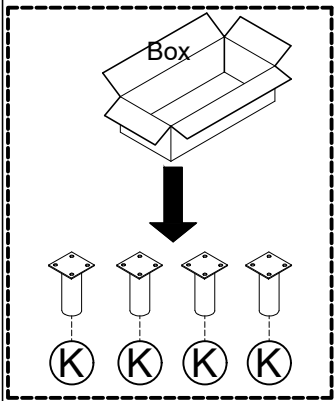
# STEP 7

F x 8 	G x 12 	H x 8 	D x 1 	K x 4 	I x 4 
--	---	--	---	--	--



# STEP 8

E x 6 	B x 6 	C x 6 	D x 1 
--	--	--	---

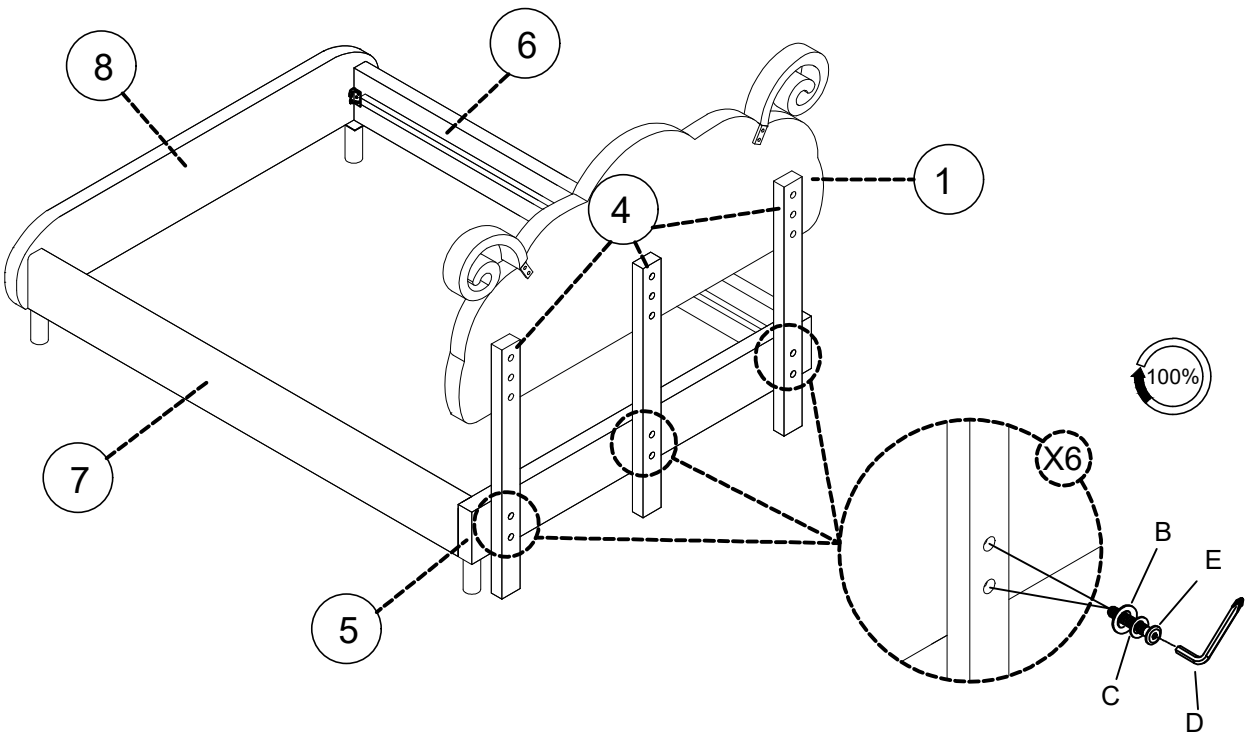



# STEP 9

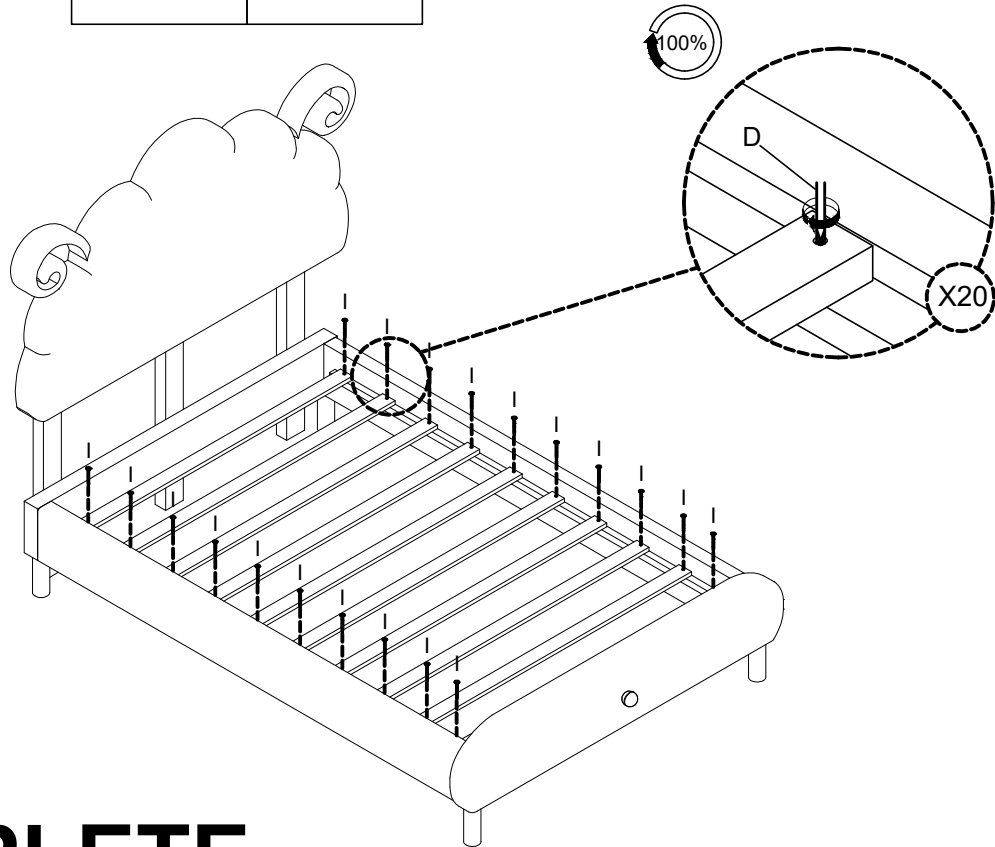
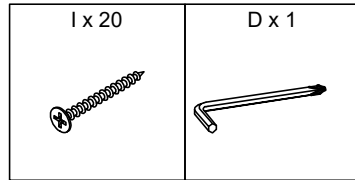

**COMPLETE**

