

WF322320
WF322321

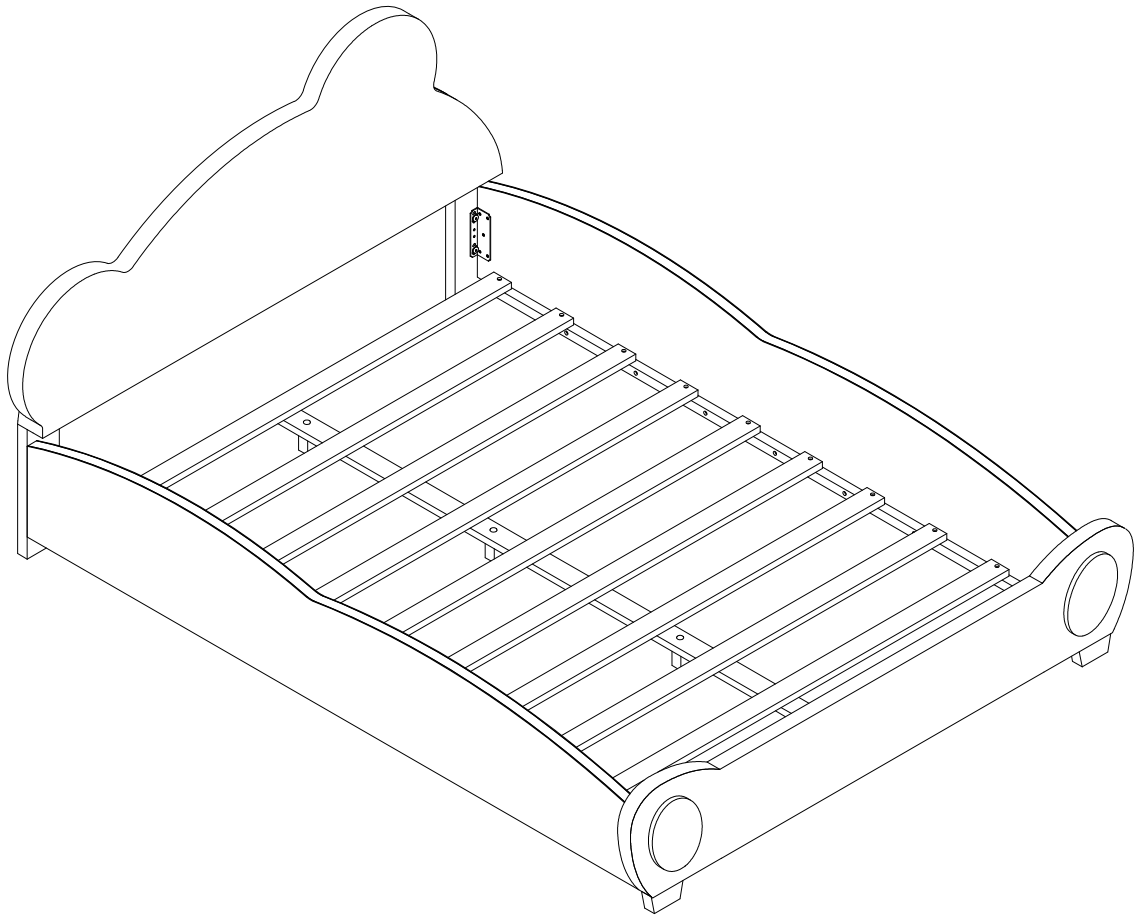

ASSEMBLY INSTRUCTIONS

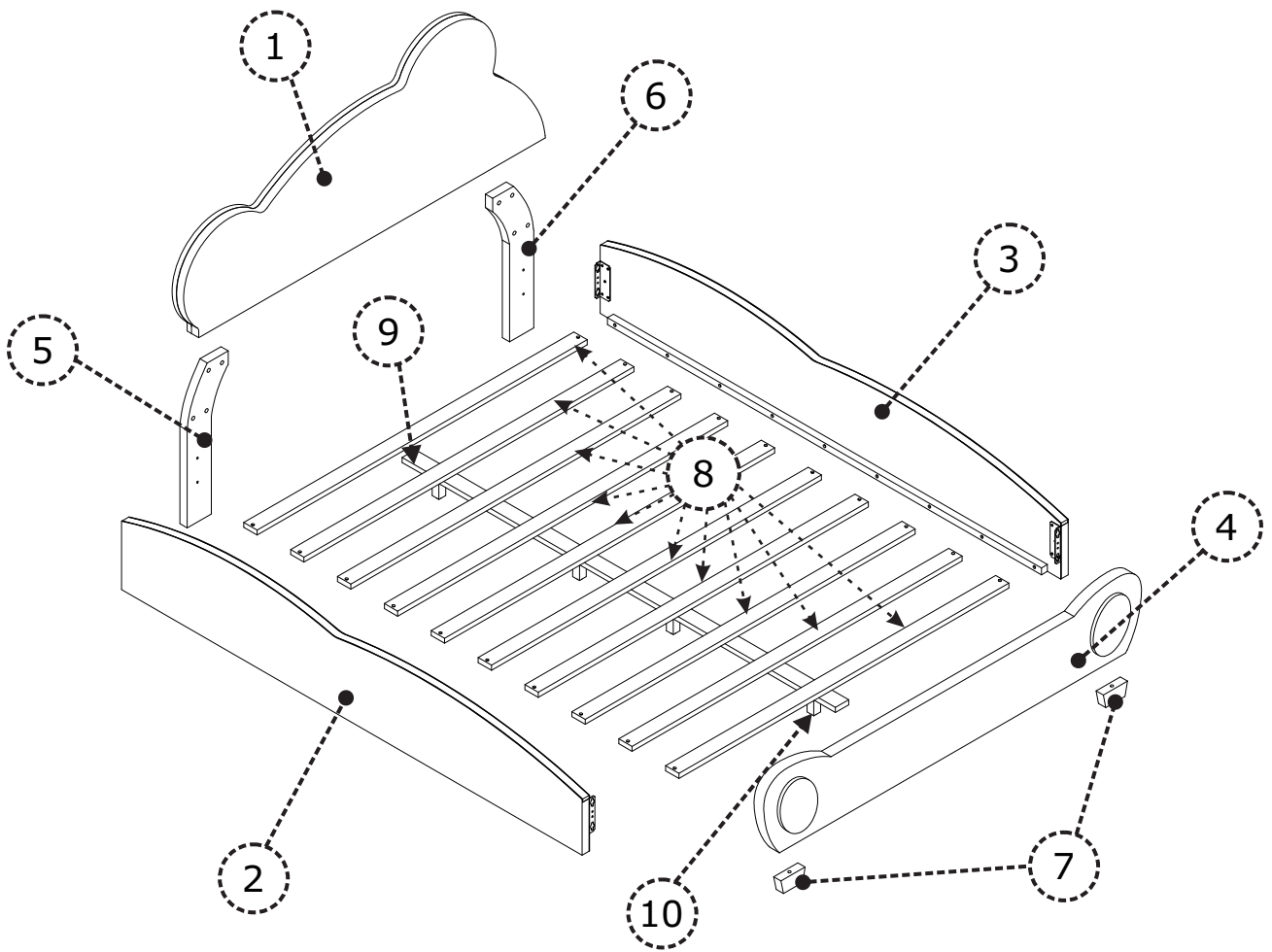

PARTS

Check that you've received
all parts listed below.

BOX: 1/2
WF322320

1 x 1

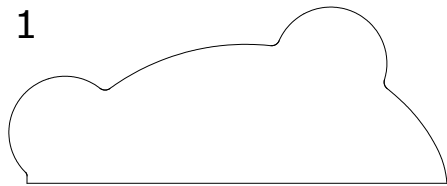

Head Board

5 x 1

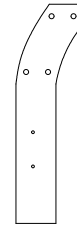

Leg Board Left

6 x 1

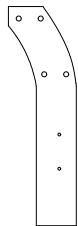

Leg Board Right

7 x 2



Legs

8 x 10

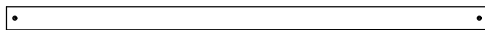

Slats

10 x 4



Support Legs

Hardware



PARTS

Check that you've received
all parts listed below.

BOX: 2/2
WF322321

2 x 1



Side Board Left

3 x 1

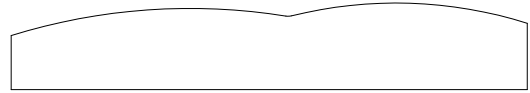

Side Board Left

4 x 1

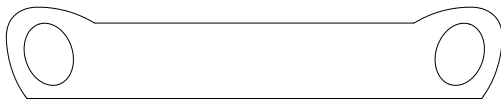

Foot Board

9 x 1

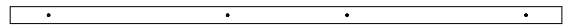







Support Slat



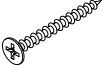

HARDWARE

Check that you've received
all hardware listed below.

Hardware List



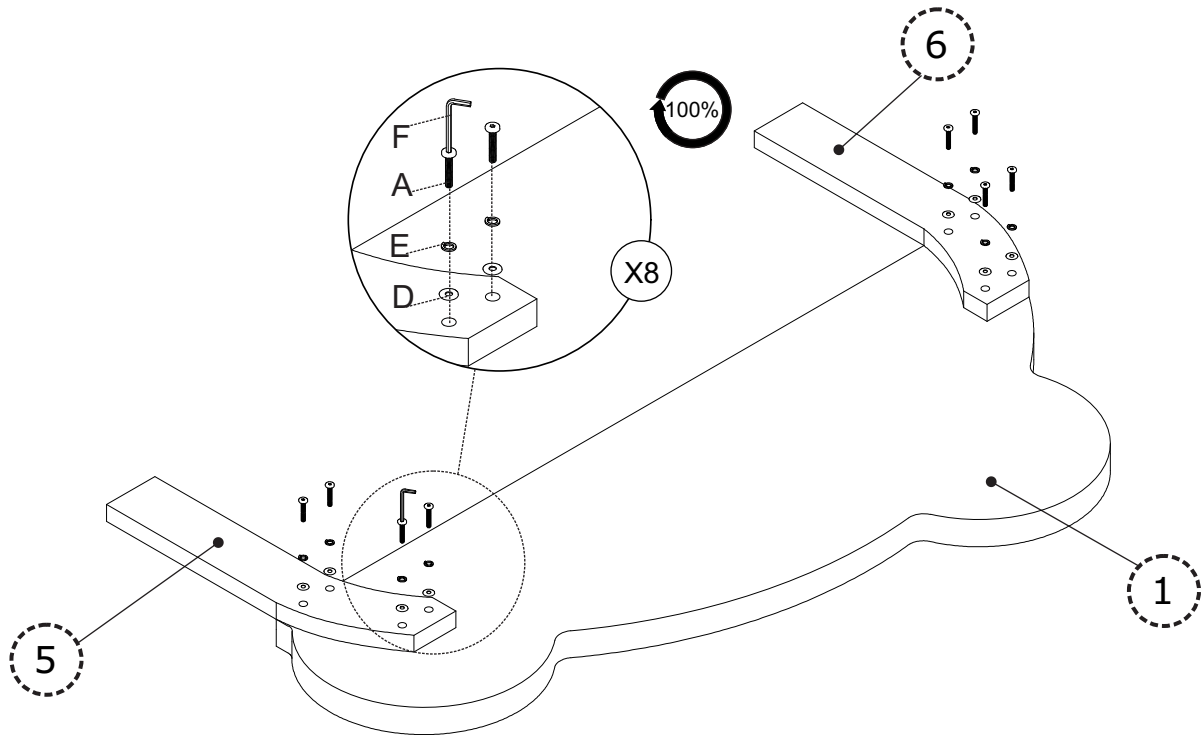

No.	OUTLOOK	DESC	QTY
(A)		Bolts 5/16"x50 mm	8
(B)		Bolts 5/16"x40 mm	2
(C)		Bolts 5/16"x30 mm	8
(D)		Plain washer Ø19x1.5 mm	18
(E)		Spring washer Ø13x1 mm	18
(F)		Allen key 80x30x4 mm	1
(G)		Screws Ø4x30 mm	20

STEP 1

A x 8 	D x 8 	E x 8 	F x 1 	
--	--	--	--	--





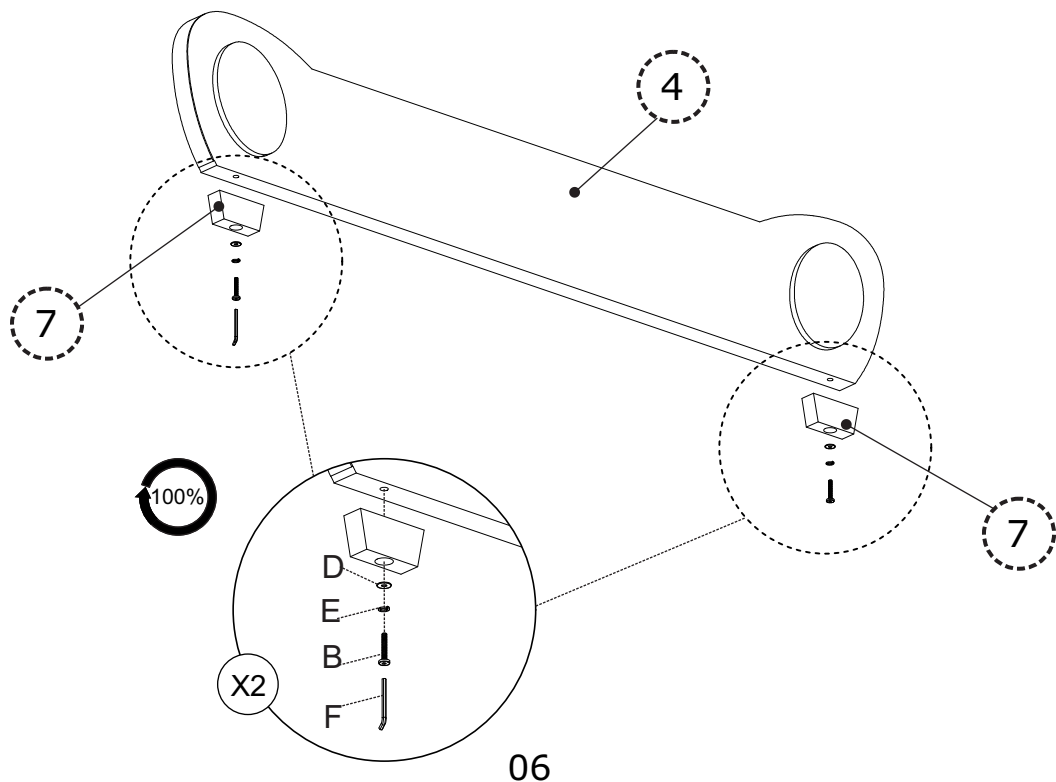

STEP 2

B x 2 	D x 2 	E x 2 	F x 1 	
--	--	--	--	--





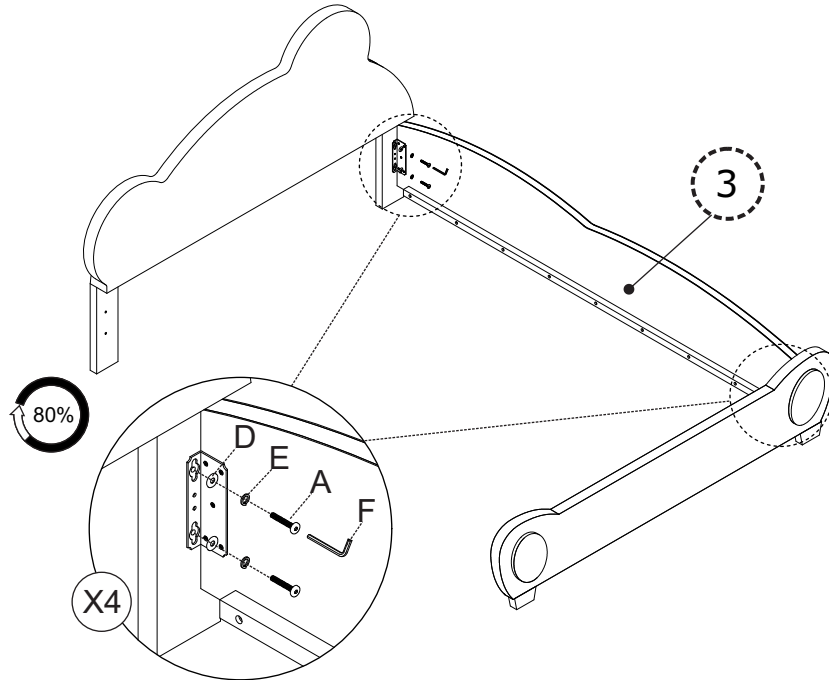

STEP 3

C x 4 	D x 4 	E x 4 	F x 1 	
--	--	--	--	--



STEP 4

C x 4 	D x 4 	E x 4 	F x 1 	
--	--	--	--	--

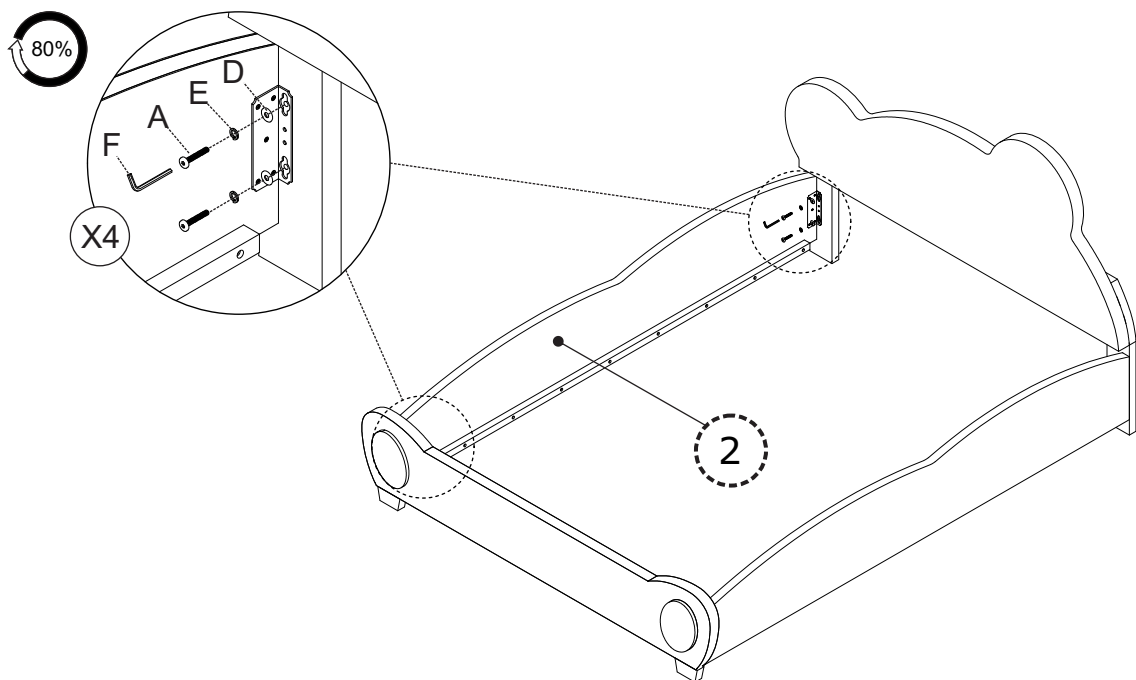

STEP 5

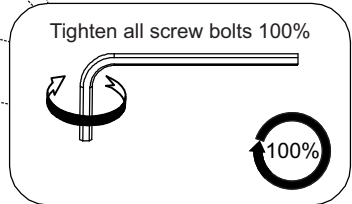
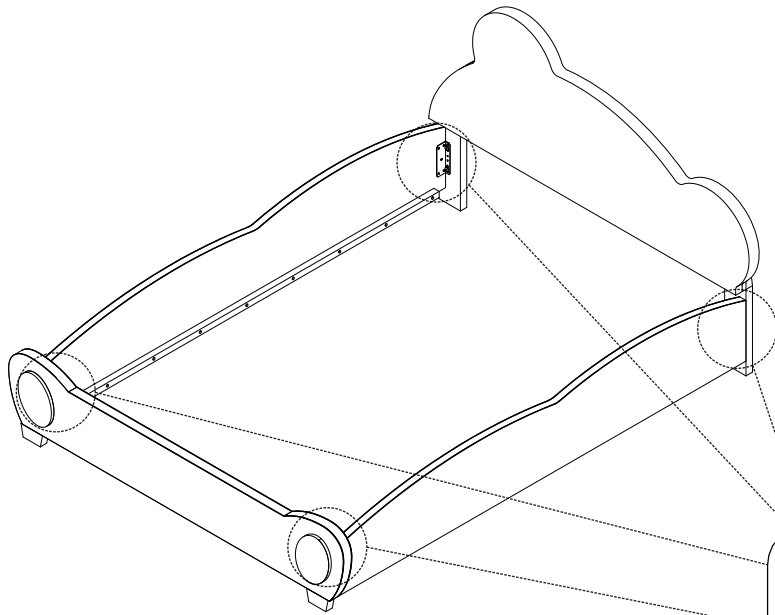
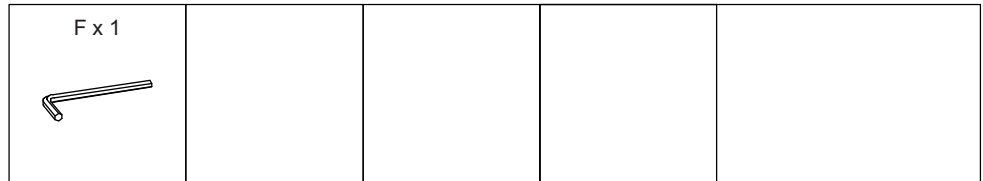

STEP 6

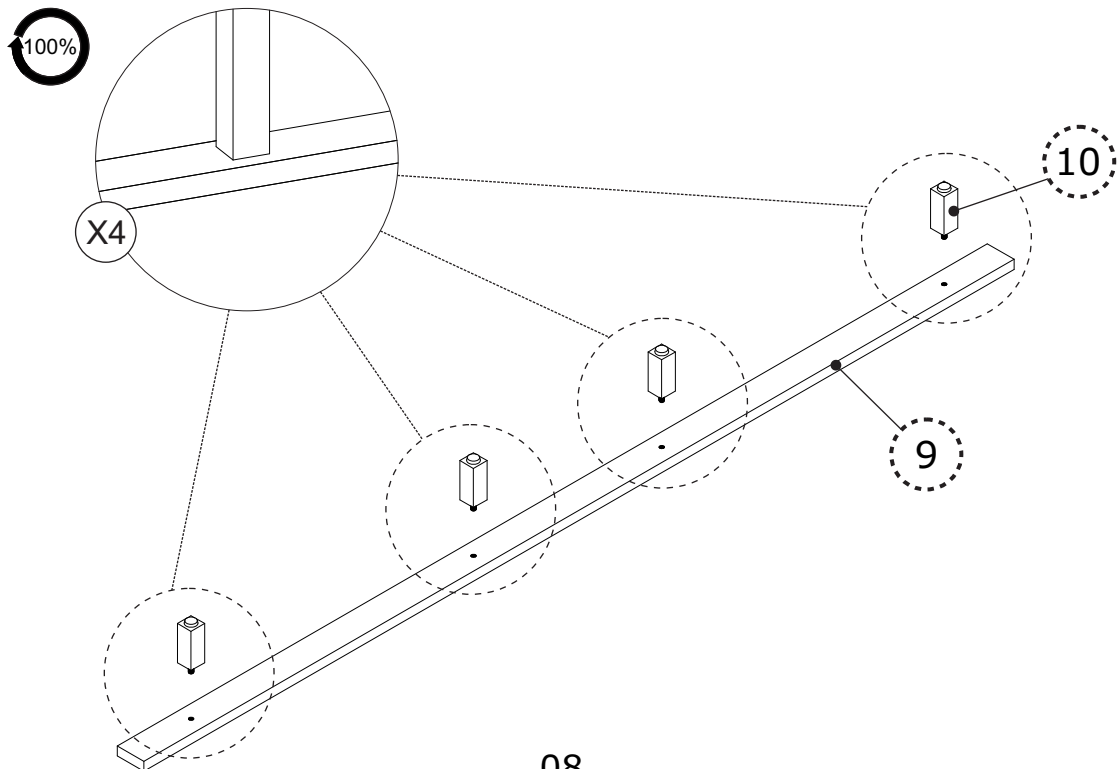
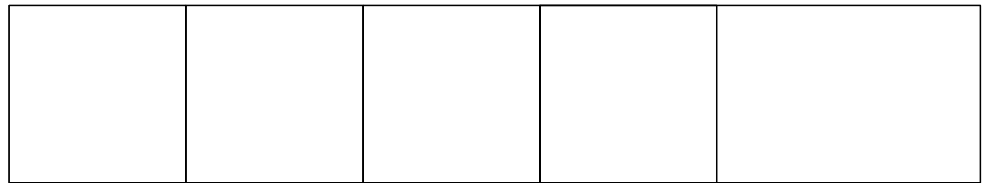

STEP 7

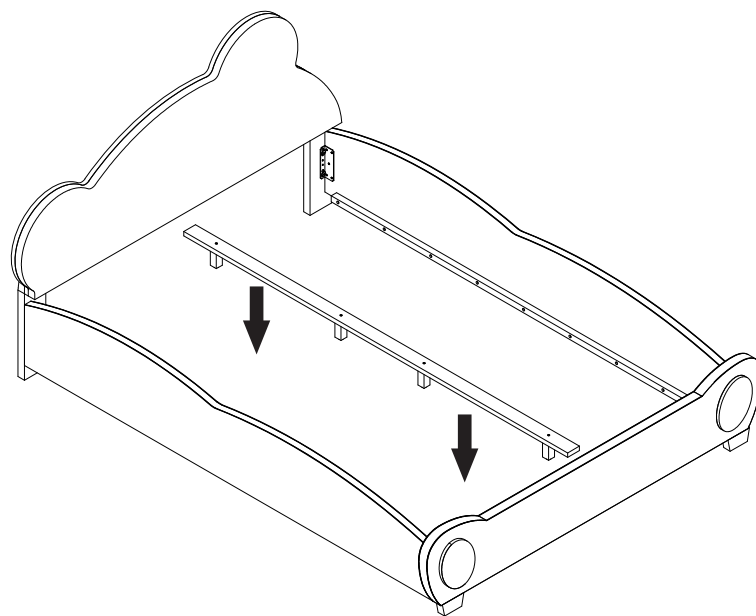
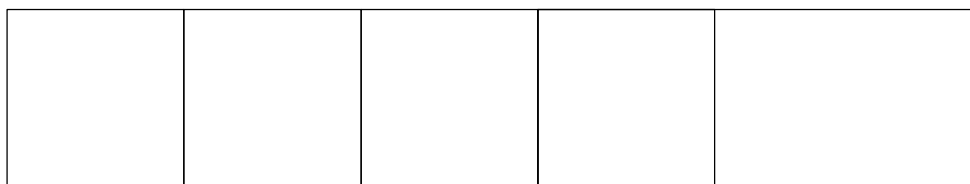

STEP 8

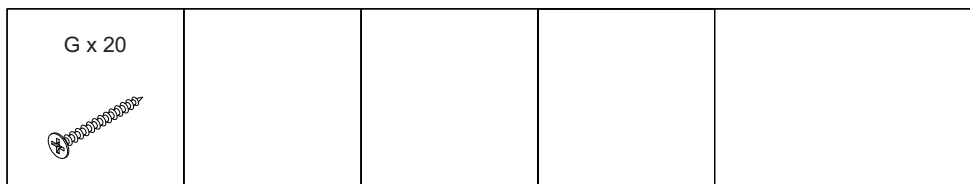

100%

