

WF322139
WF322140

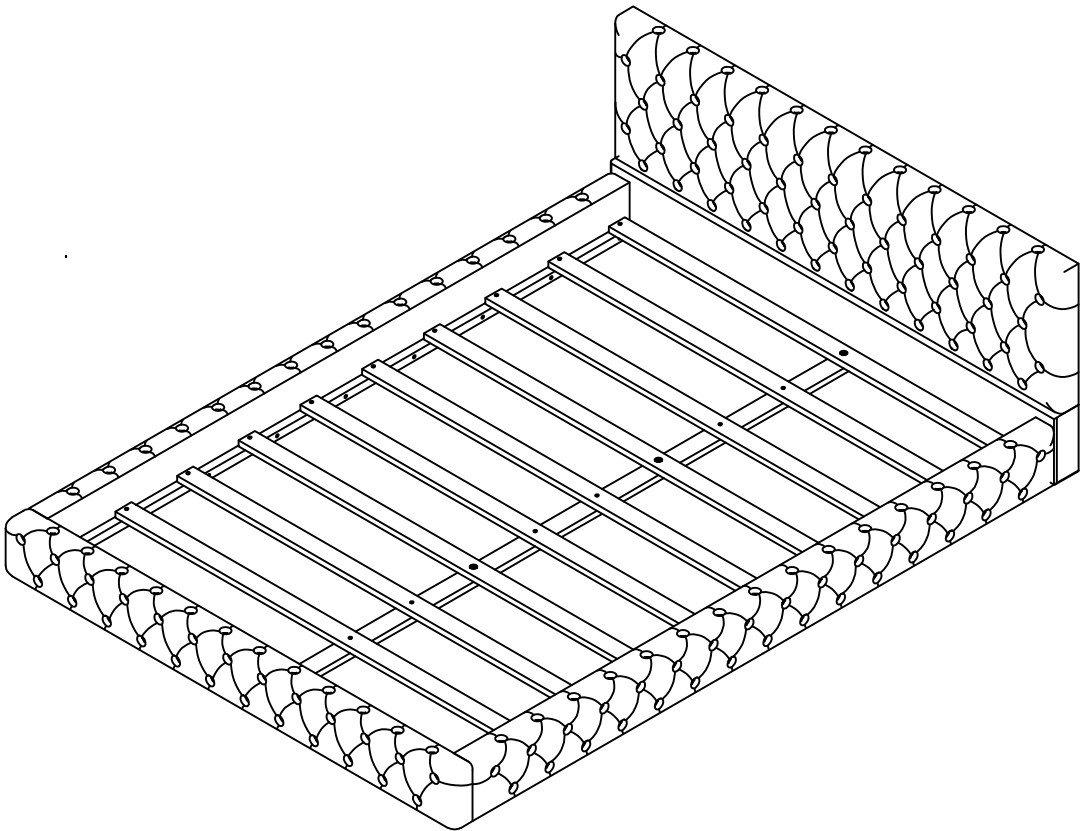

ASSEMBLY INSTRUCTIONS

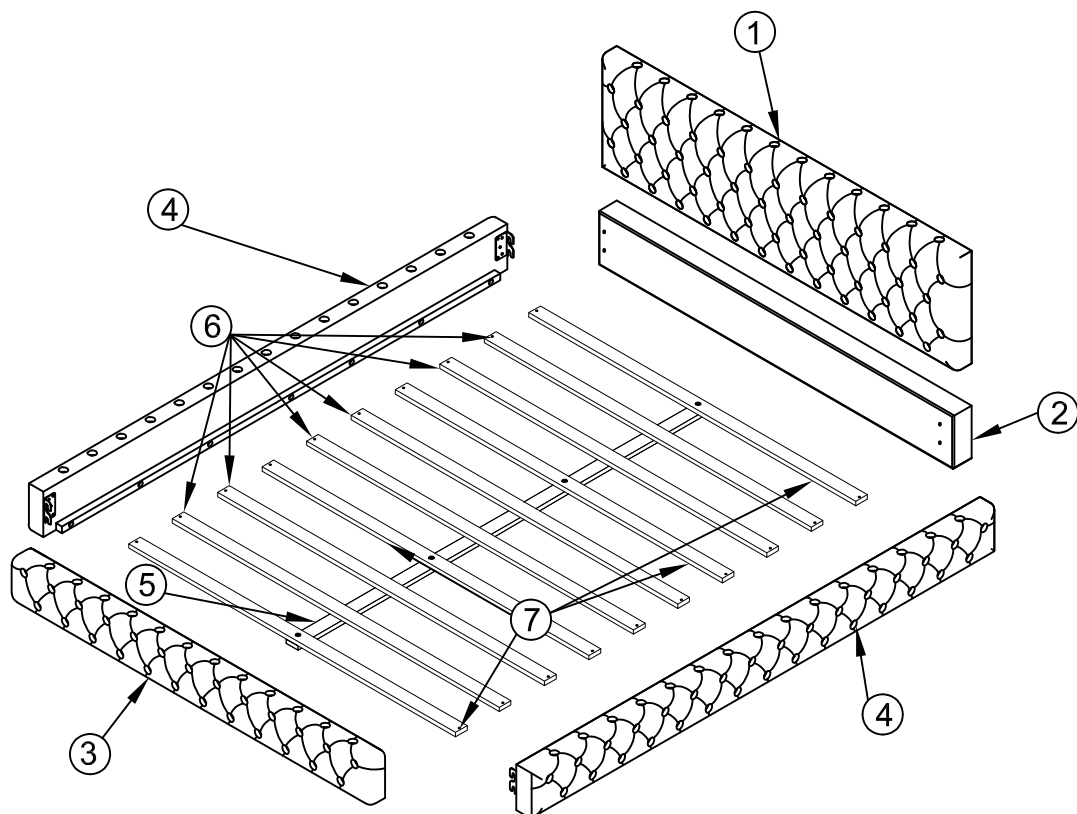

PARTS | check that you've received all parts listed below

BOX:1/2
WF322139

① (1PC)

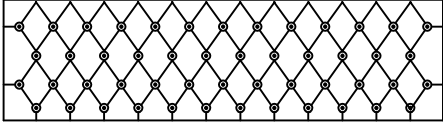

② (1PC)



③ (1PCS)

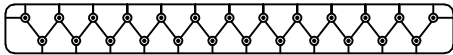

⑤ (2PCS)

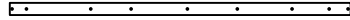

⑥ (6PCS)

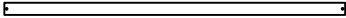

⑦ (4PCS)



HARDWARE



PARTS | check that you've received all parts listed below

BOX:2/2
WF322140



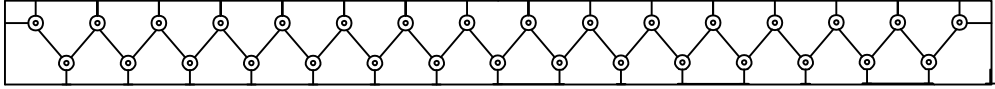



④ (2PCS)

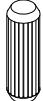

HARDWARE

check that you've received
all parts listed below

Hardware List

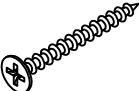
NO	OUTLOOK	DESC	QTY
A		Bolts $\varnothing \frac{5}{16}$ " x 35 mm	12 pcs
B		Bolts $\varnothing \frac{5}{16}$ " x 40 mm	4pcs
C		Wooden Pegs $\varnothing 10 \times 30$ mm	2 pcs
D		Plain washer $\varnothing 19 \times 1.5$ mm	16 pcs
E		Spring washer $\varnothing 13 \times 1$ mm	16 pcs
F		Allen key 80x30x4 mm	1 pc
G		Screws $\varnothing 4 \times 30$ mm	24 pcs

STEP 1

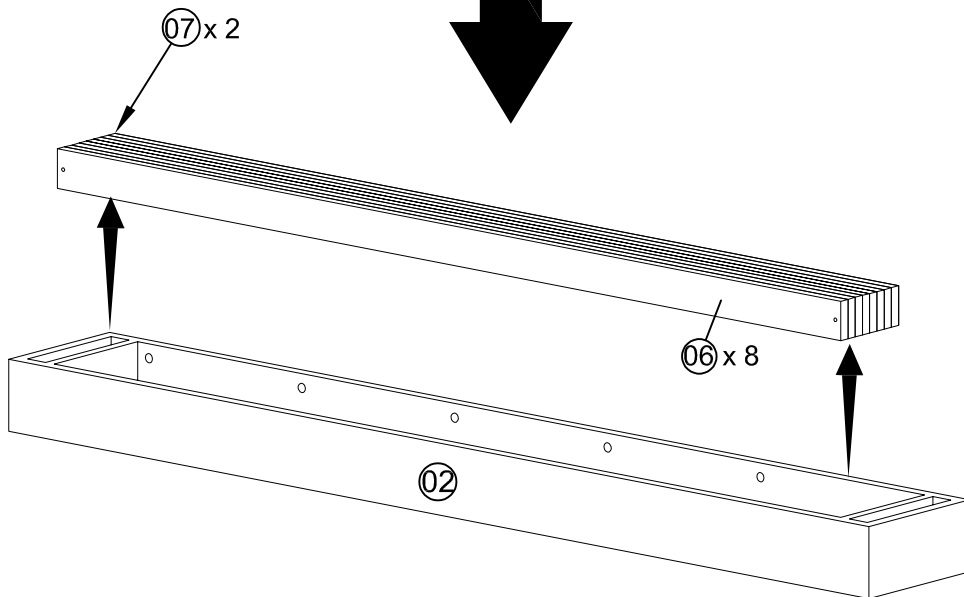
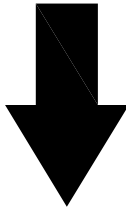
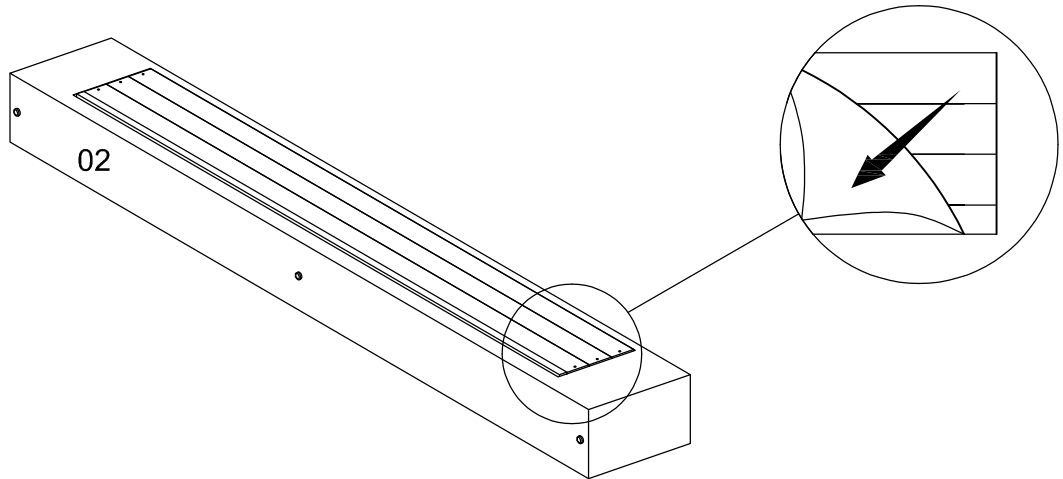

STEP 2

Bx4	Cx2	Dx4	Ex4	Fx4	
-----	-----	-----	-----	-----	--

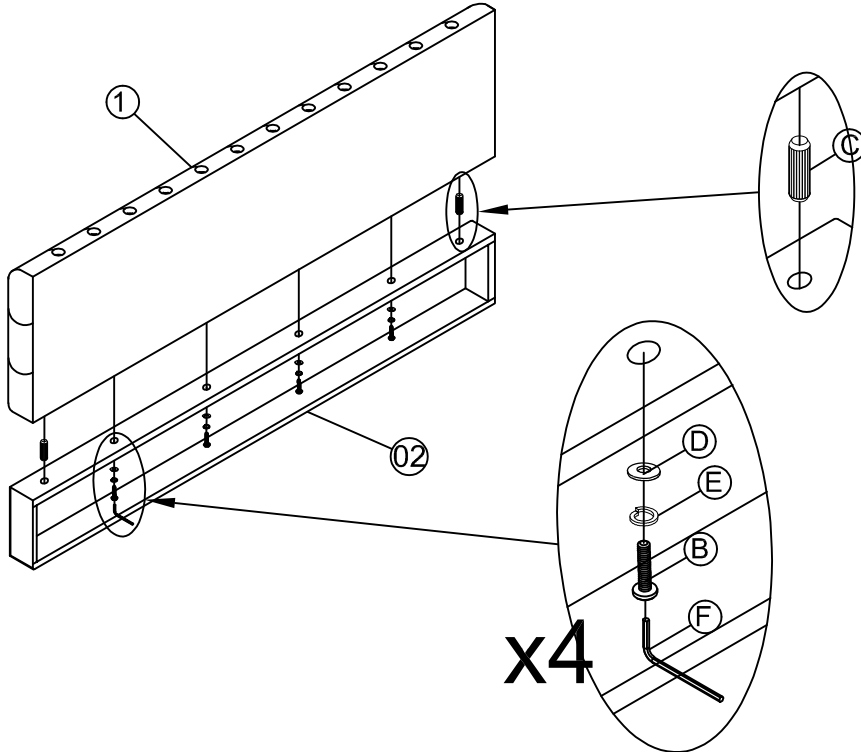

STEP 3

Ax2	Dx4	Ex4	Fx4	
-----	-----	-----	-----	--

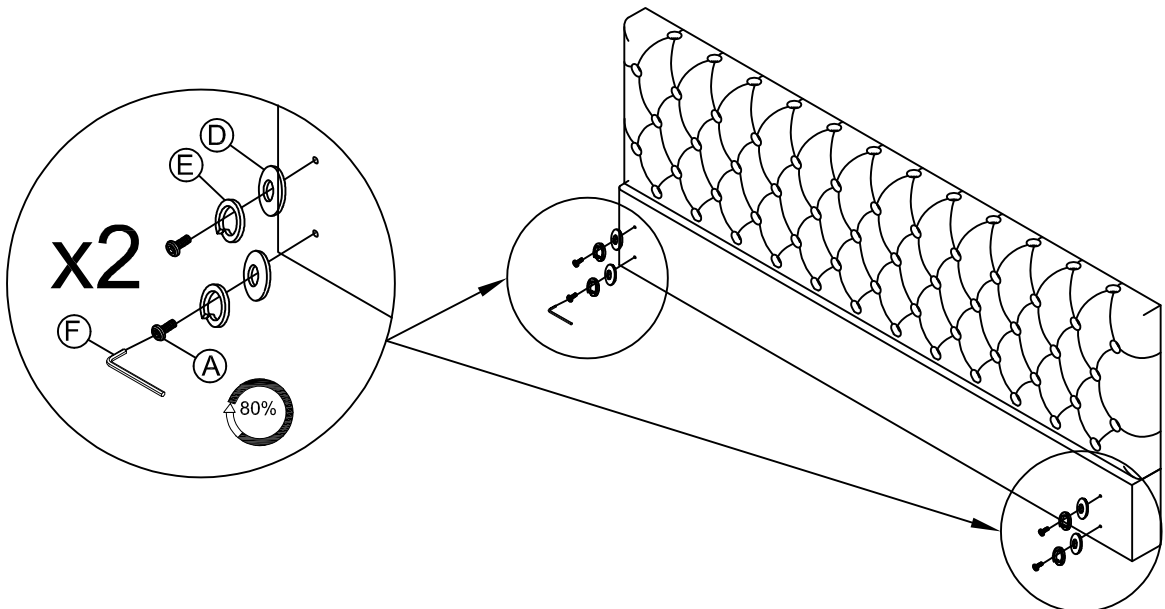



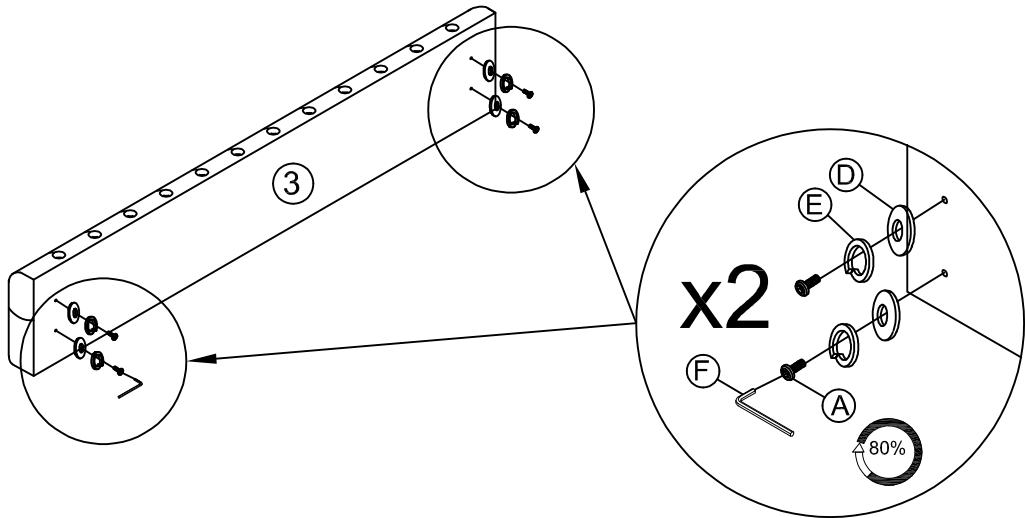
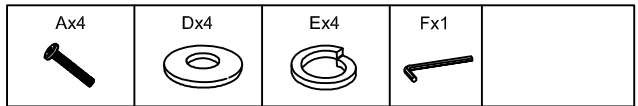

STEP 4

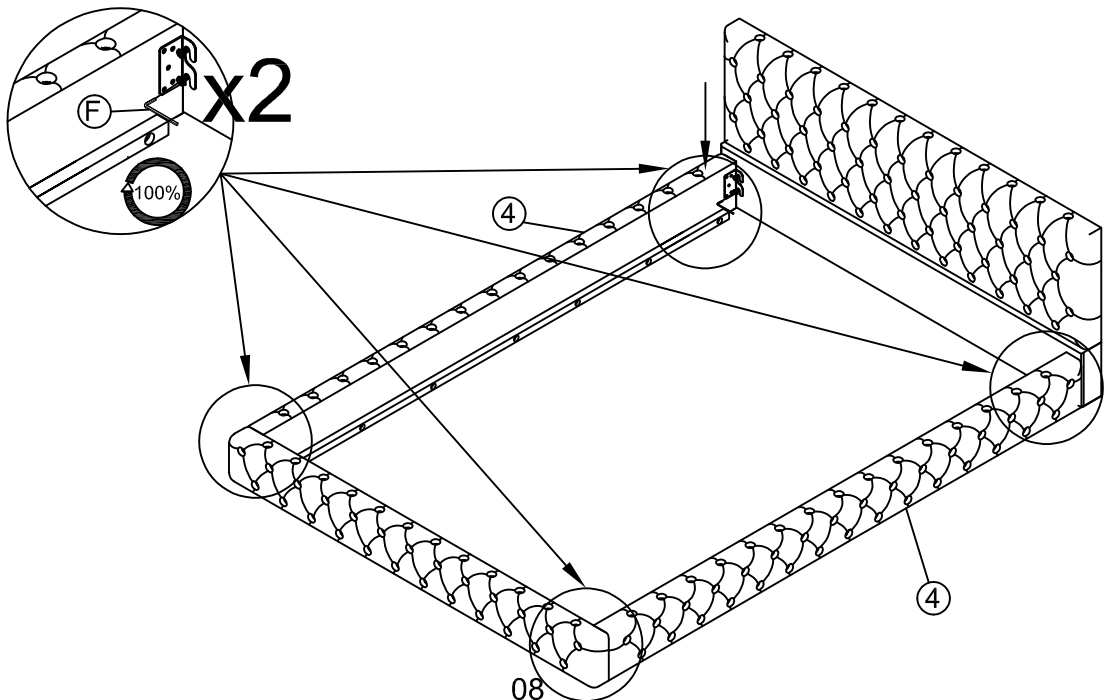

STEP 5



STEP 6

Gx20	Ax4	Dx4	Ex4	Fx1
				

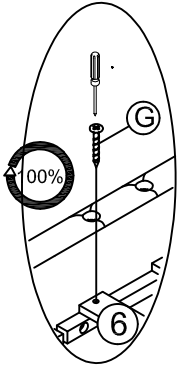

x20

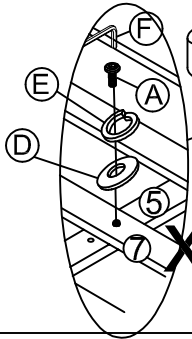

x4

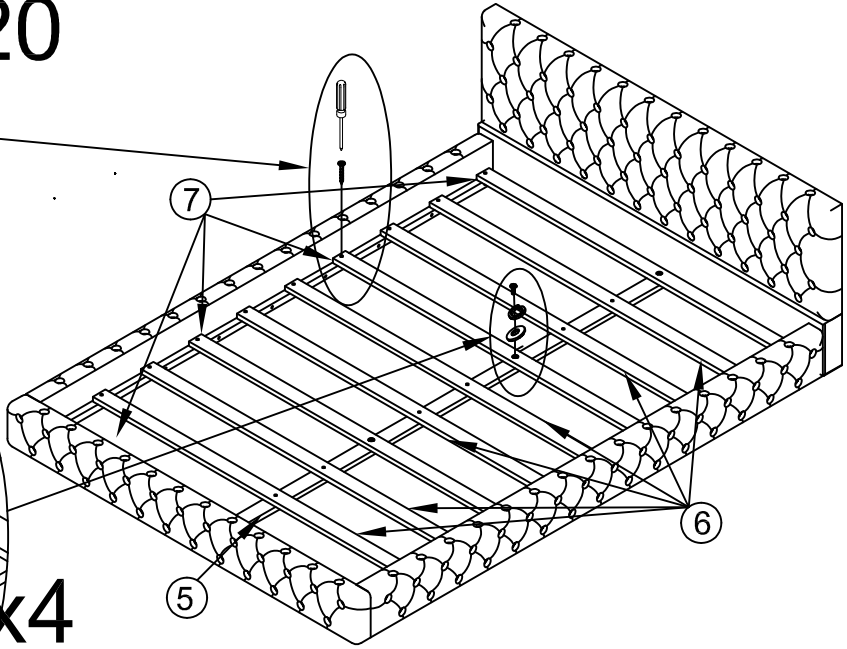

finish

