

ASSEMBLY INSTRUCTION

WAVE BED (USA) QUEEN/FULL

WF313806/WF313807

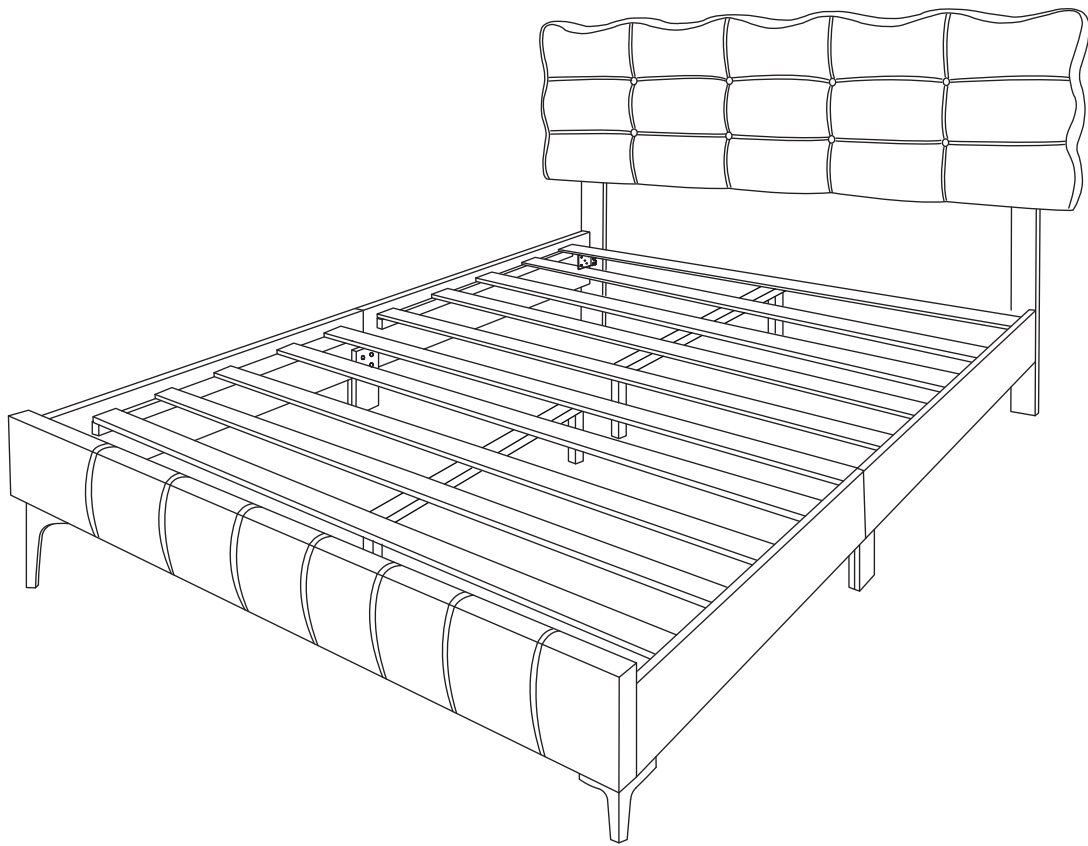



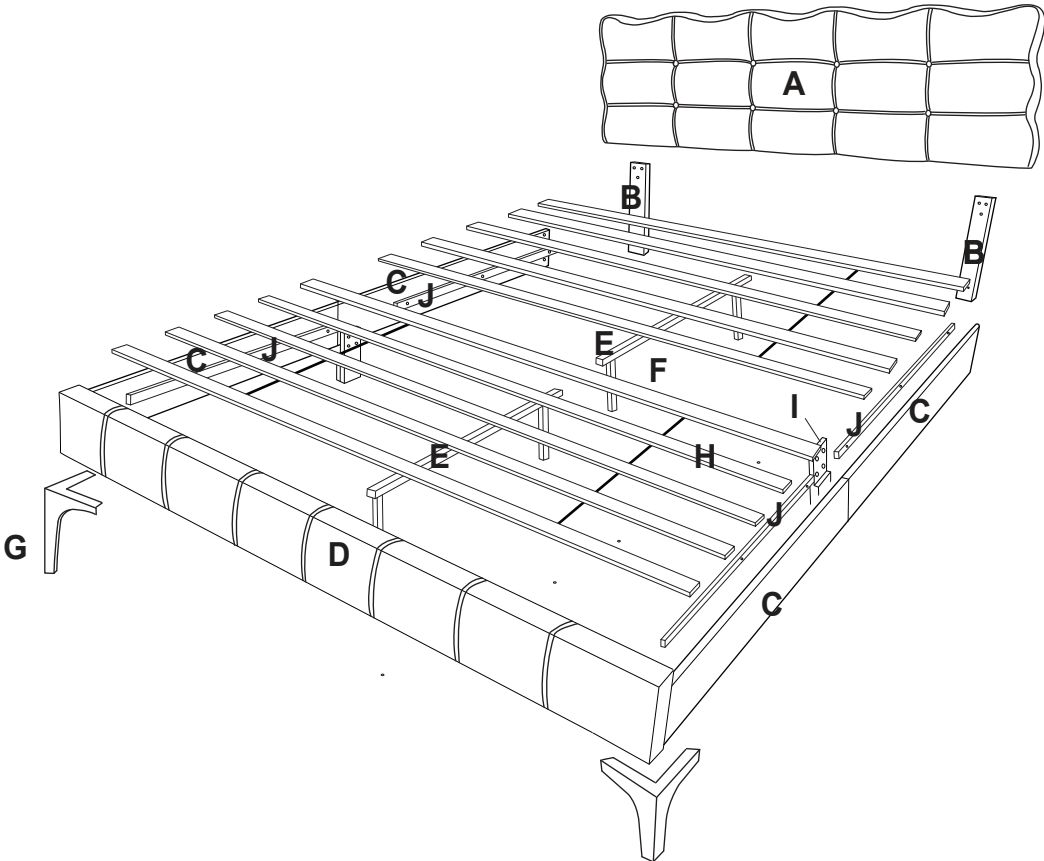



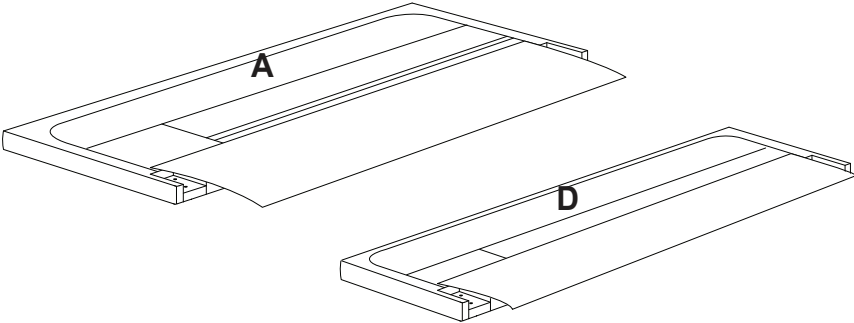

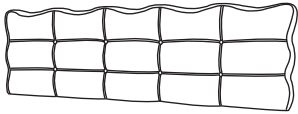
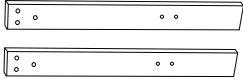
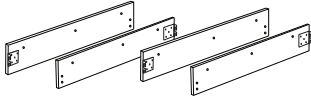
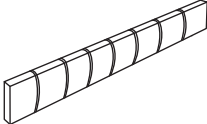
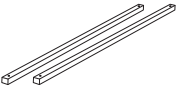
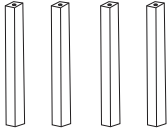
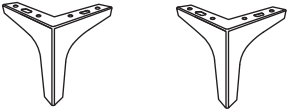
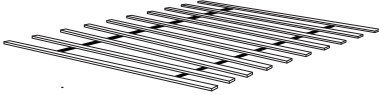
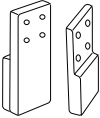
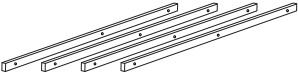
Detail View - WAVE BED



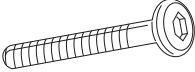
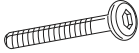
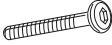

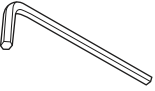
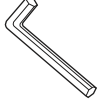
Bed Parts are shipped inside a compartment in the back of the headboard & footboard.

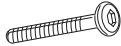

NO	PARTLIST	QTY
A	Headboard 	1 pc
B	Headboard Leg 	2 pcs
C	Side Rail 	4 pcs
D	Footboard 	1 pc
E	Center Support Rail 	2 pcs
F	Center Support Leg 	4 pcs
G	Bed Leg 	2 pcs
H	Bed Slat 	10 pcs
I	Side Rail Support 	2 pcs
J	Slat Support 	4 pcs

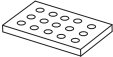
NO	HARDWARE LIST	QTY
1	JCBB M8 x 20mm 	8 pcs
2	JCBC M6 x 60mm 	4 pcs
3	JCBC M6 x 40mm 	6 pcs
4	JCBC M6 x 25mm 	8 pcs
5	Spring Washer M6 	6 pcs
6	Flat Washer M6 	14 pcs
7	Allen Key M4 	1 pcs
8	Allen Key M5 	1 pcs
9	Adjuster M6 	4 pcs
10	CSK M4 x 20mm 	6 pcs
11	CSK M4 x 30mm 	20 pc
12	JCBB M6 x 30mm 	12 pcs

NO	HARDWARE LIST	QTY
13	Adapter 	1 pc
14	Remote 	1 pc
15	LED light 	1 pc
16	Controller box 	1 pc



Read this instruction carefully. Remove all wrapping material, staples and straps from the carton. See hardware and furniture part list for guidance. Be sure you have all wooden furniture parts on a clean and flat surface, such as carpet or rug, to prevent from being scratched.

CAUTION :

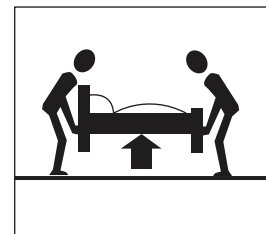
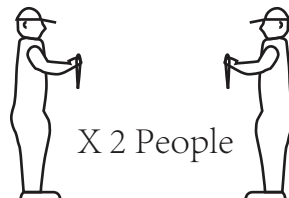
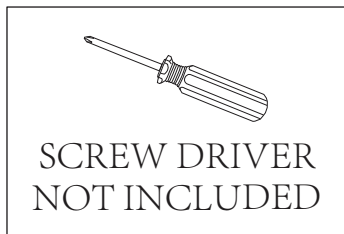
1. Do not Full Tighten the nut or screw until all ready to assemble.
2. Do not Over Tighten the nut or screw to avoid causing damages to the thread.
3. Keep all hardware part out reach of children.



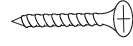

STEP 1

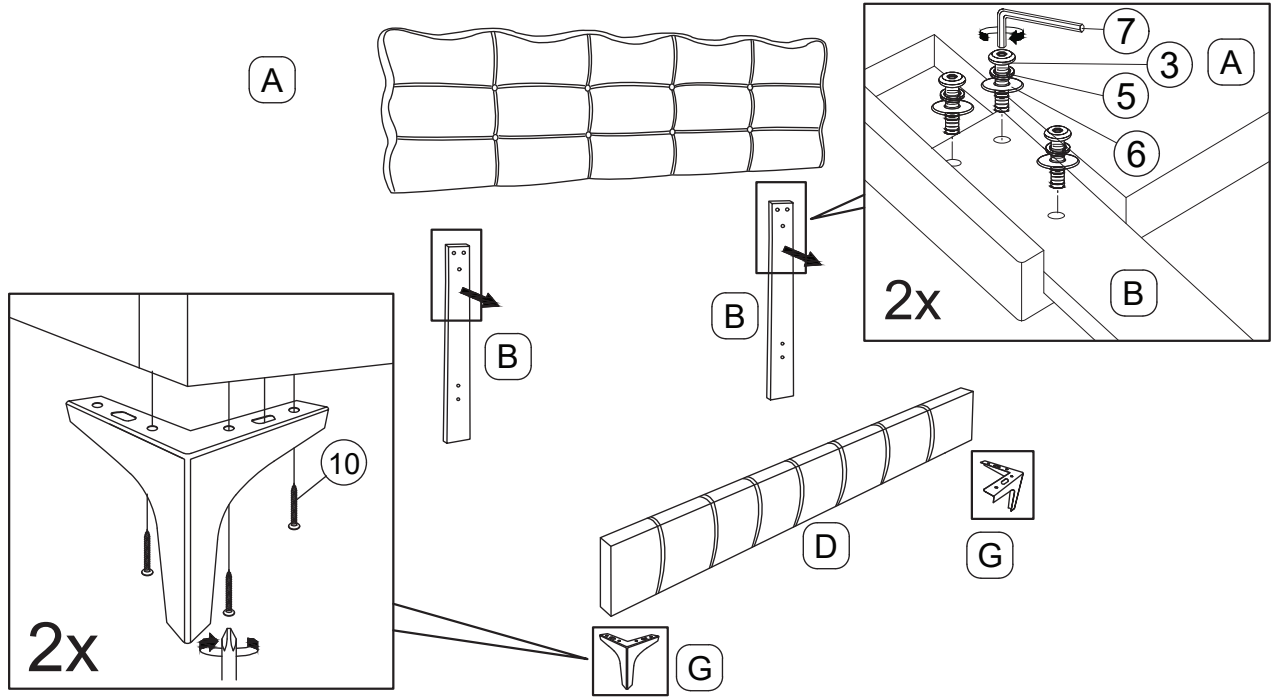
3	10	6	5
			
6 pcs	20 pcs	6 pcs	6 pcs

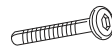

STEP 2

12	4	6
		
12 pcs	8 pcs	8 pcs

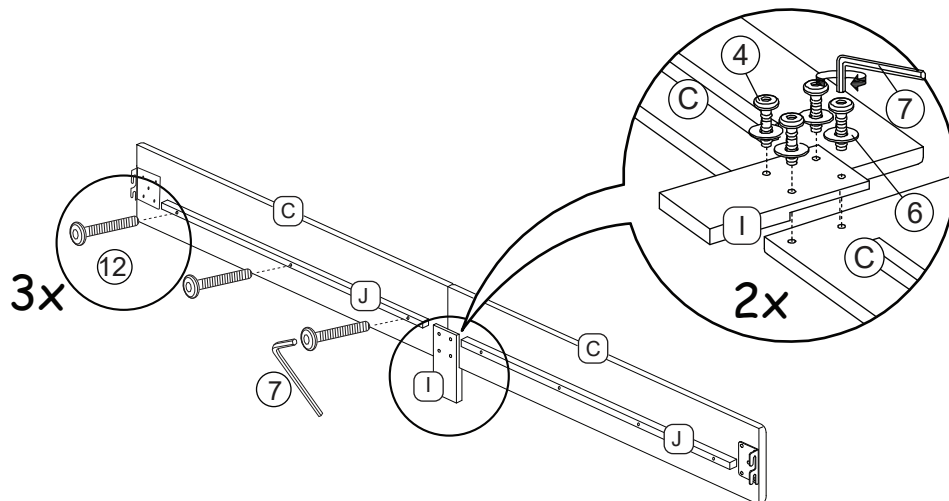



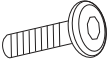

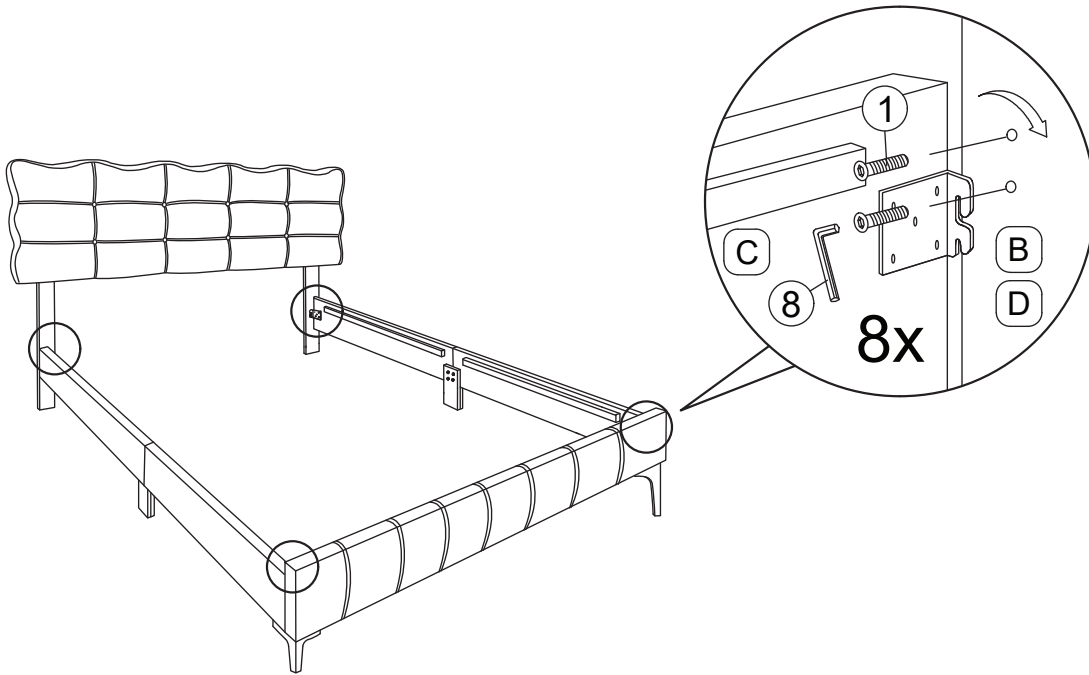
STEP 3

1

8 pcs

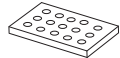

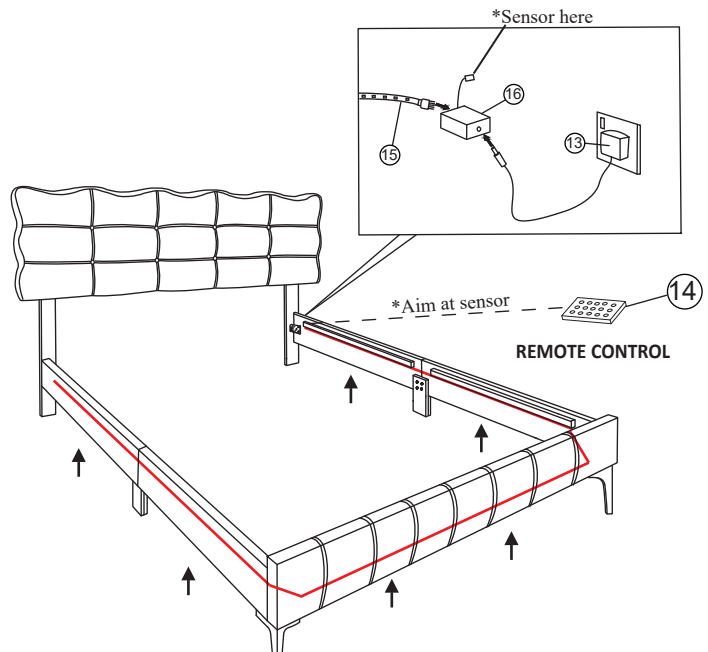

STEP 4

16	13	14	15
			
1 pc	1 pc	1 pc	1 pc

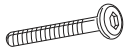

*Attach the velcro side of the LED light to the corresponding velcro tape under the slat support and footboard.

STEP 5

2	9
	
4 pcs	9 pcs

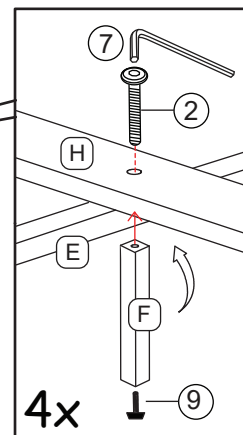
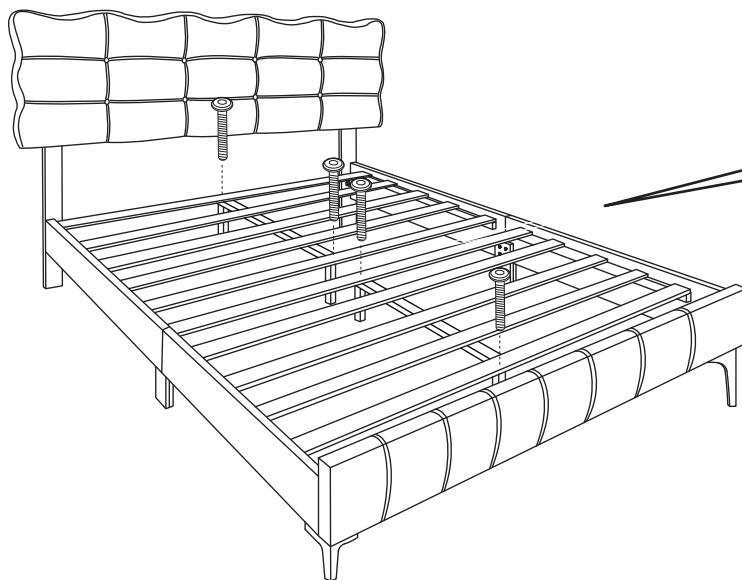

STEP 6

11

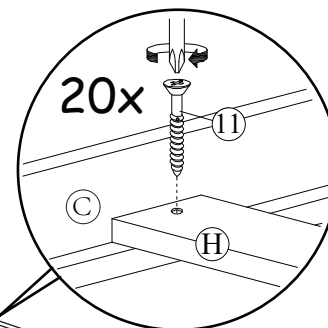
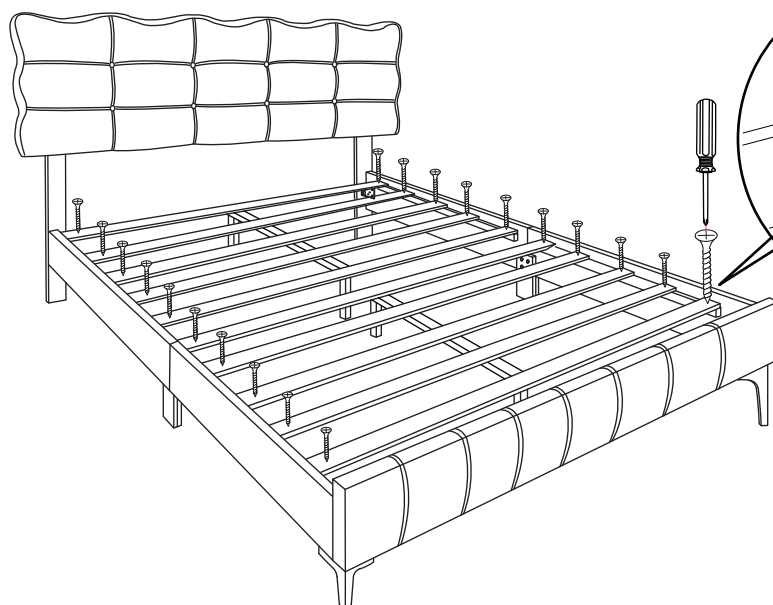
20 pcs

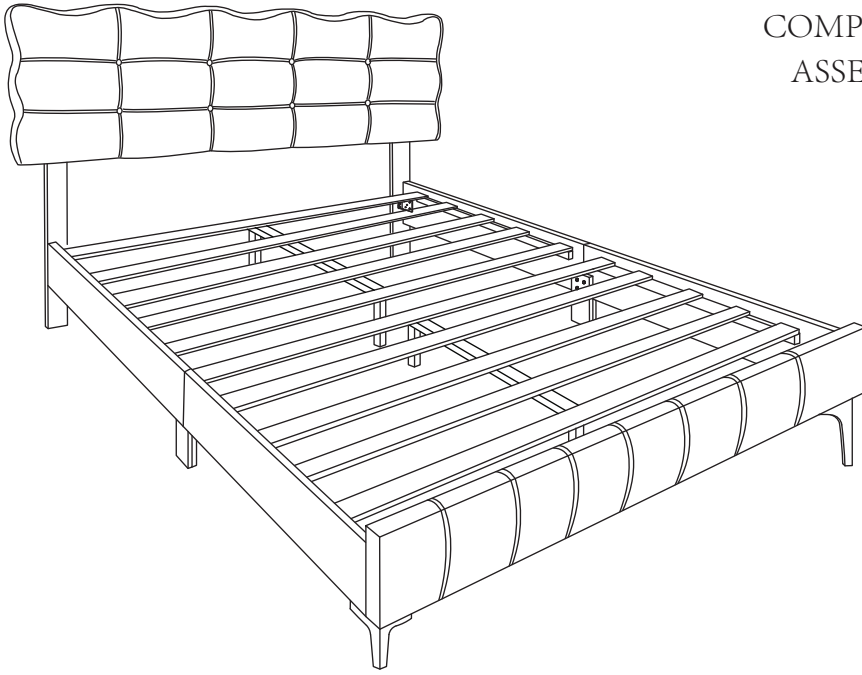



COMPLETED
ASSEMBLY