

ASSEMBLY INSTRUCTION

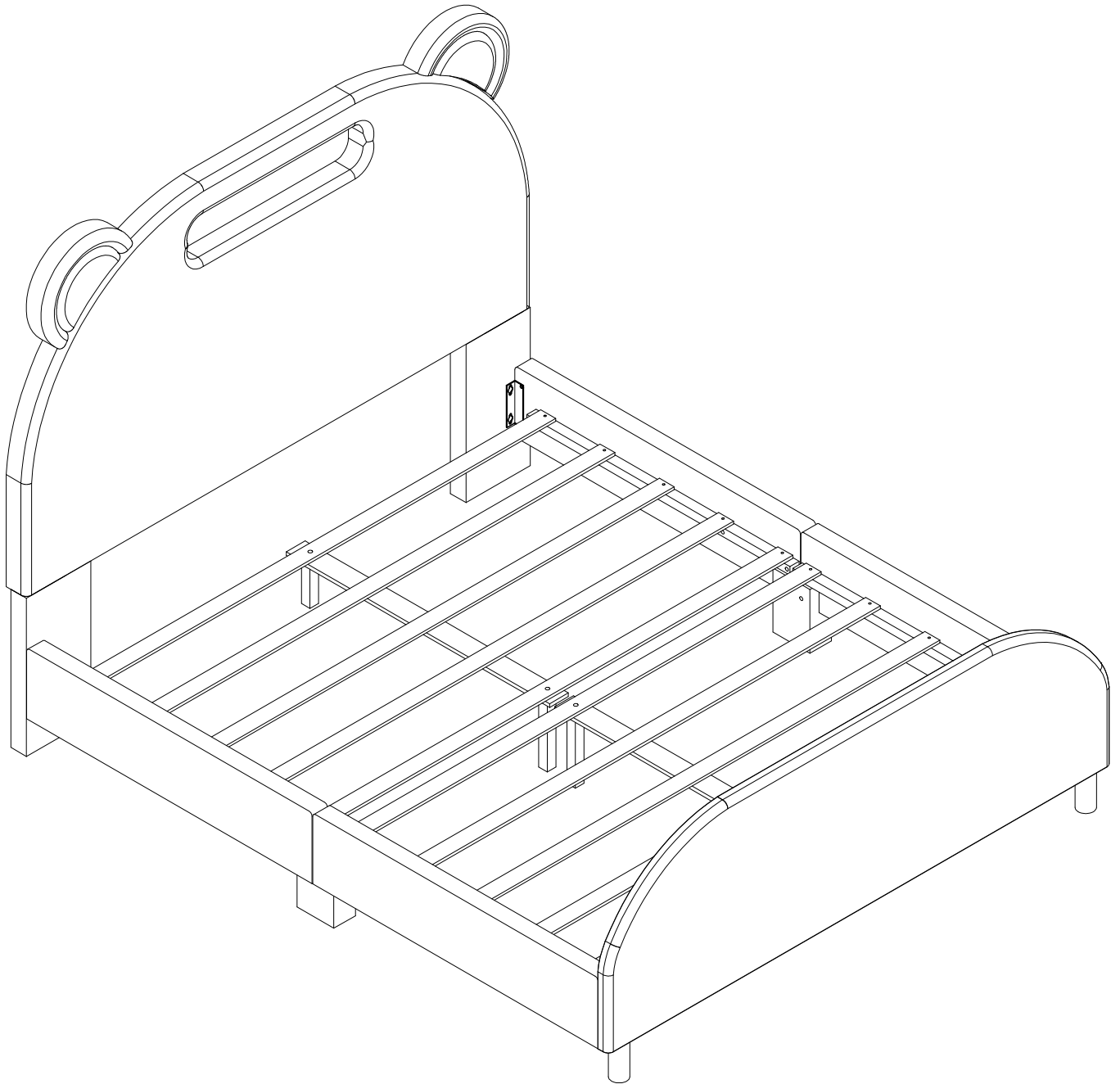

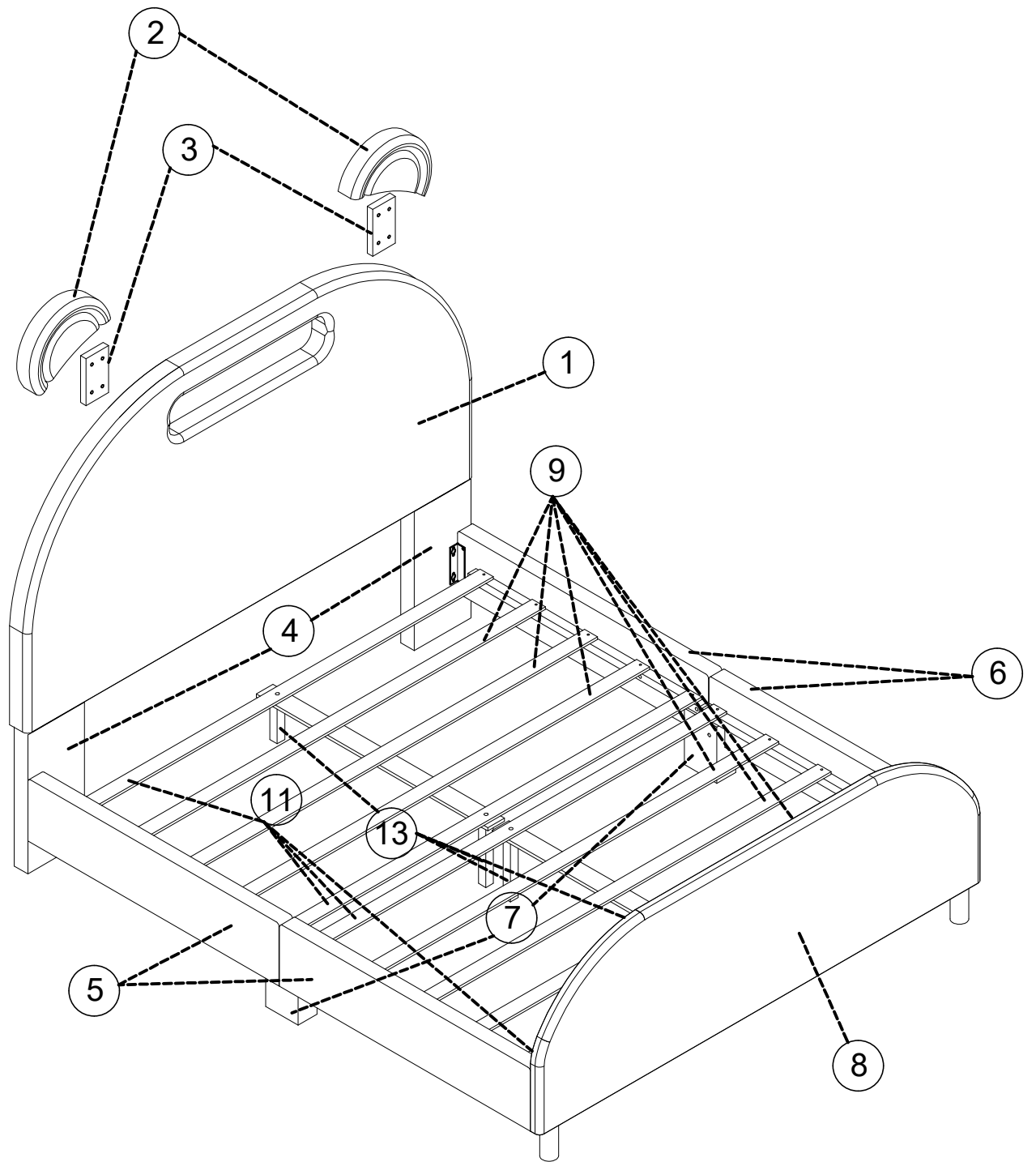





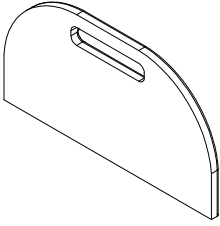

SKU CODE: (WF316215AAA/WF316215AAH)

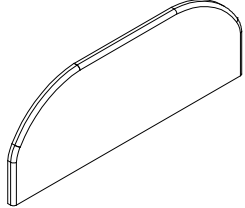
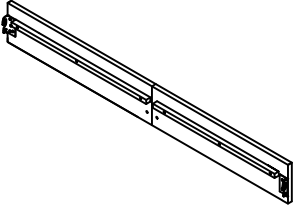
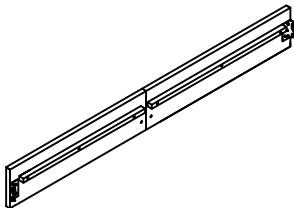
This set included 1 boxex if do not receive full 1 boxex. Please contact our customer service team

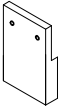
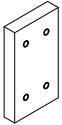

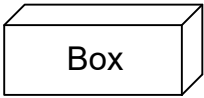

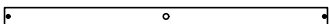











Part List

<p>1</p>  <p>Head board Left-1pc</p>	<p>2</p>  <p>Wing board Right-2pcs</p>	<p>8</p>  <p>Footboard-1pc</p>
<p>5</p>  <p>Side rail Left-2pcs</p>	<p>6</p>  <p>Side rail Left-2pcs</p>	<p>4</p>  <p>Head board legs-2pcs</p>
<p>7</p>  <p>Side legs-2pcs</p>	<p>3</p>  <p>Connect Wing & Headboard-2pcs</p>	<p>9</p>  <p>Slates-6pcs</p>
<p>10</p>  <p>Box-Charging and controller-1pc</p>	<p>12</p>  <p>Bed support Slates-2pcs</p>	<p>11</p>  <p>Slates-4pcs</p>
<p>13</p>  <p>Legs middle-4pcs</p>	<p>Hardware</p>  <p>03</p>	





HARDWARE

Check that you've received
all hardware listed below.

Hardware List



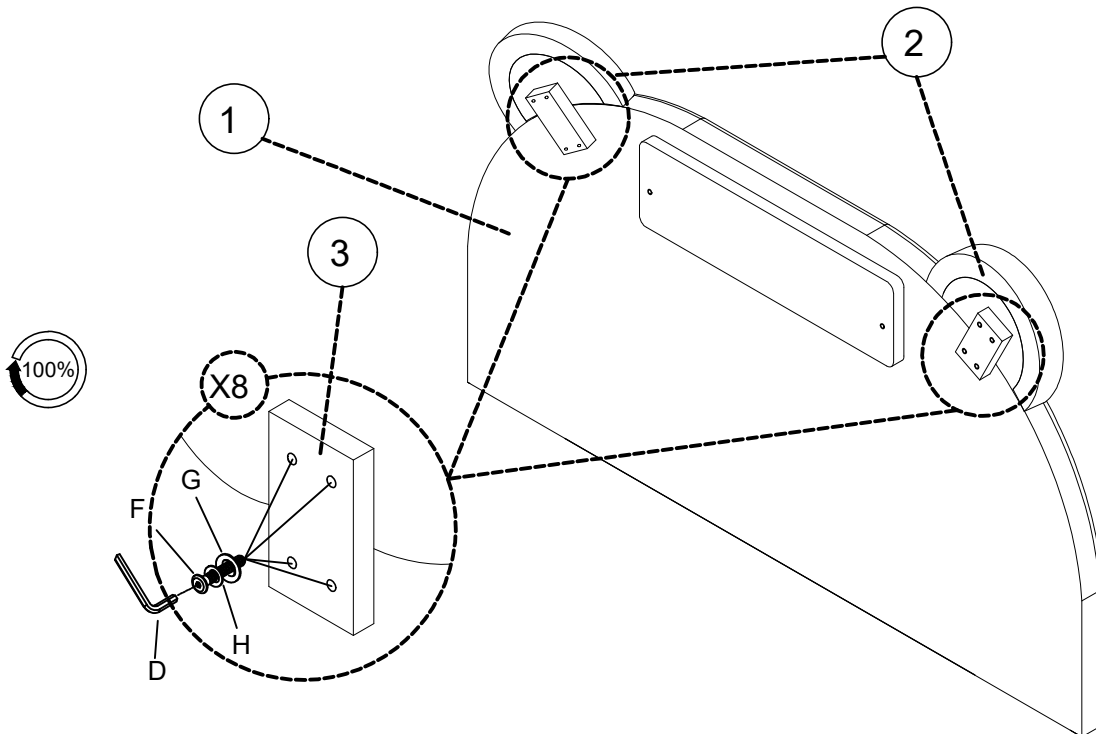

No.	OUTLOOK	DESC	QTY
(A)		Bolts 5/16"x30 mm	8
(B)		Plain washer Ø5/16"x19x1.5 mm	24
(C)		Spring washer Ø5/16"x12 mm	24
(D)		Allen key 80x30x4 mm	1
(E)		Bolts 5/16"x38 mm	12
(F)		Bolts 1/4"x30 mm	8
(G)		Plain washer Ø1/4"x19x1.5 mm	8
(H)		Spring washer Ø1/4"x10 mm	8
(I)		Screws Ø4x30 mm	20
(K)		Screws Ø4x15 mm	4
(L)		Metal bas	2
(M)		Legs Ø50	2
(N)		Bolts 5/16"x45 mm	4

STEP 1

F x 8	G x 8	H x 8	D x 1
			





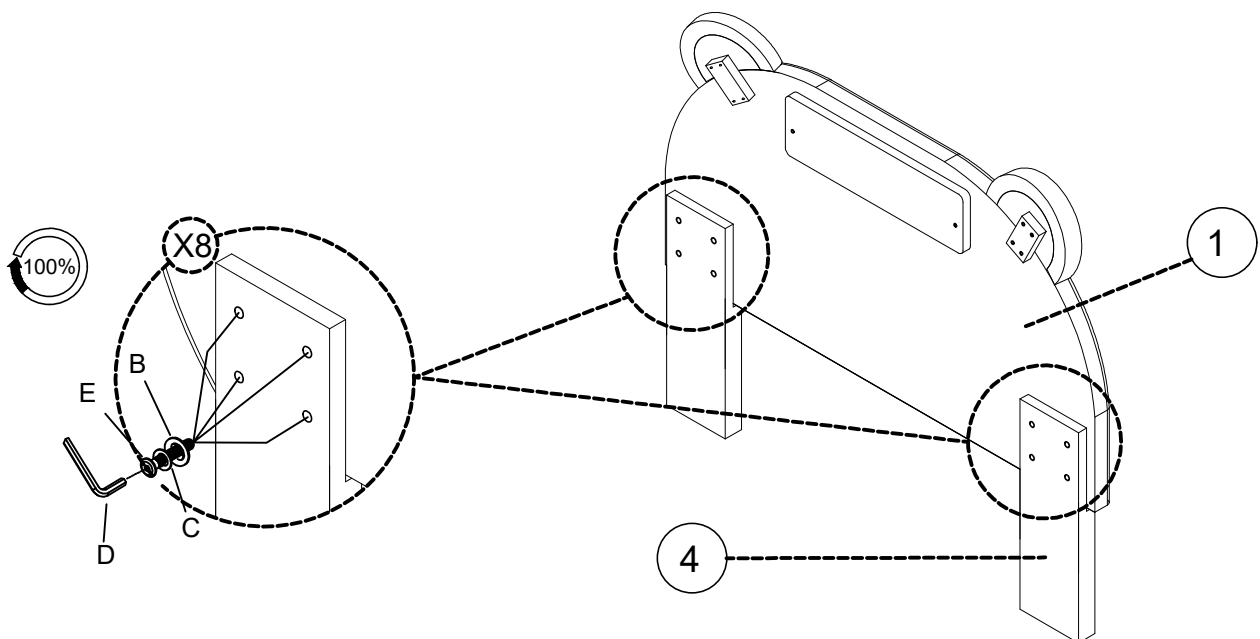

STEP 2

E x 8	B x 8	C x 8	D x 1
			



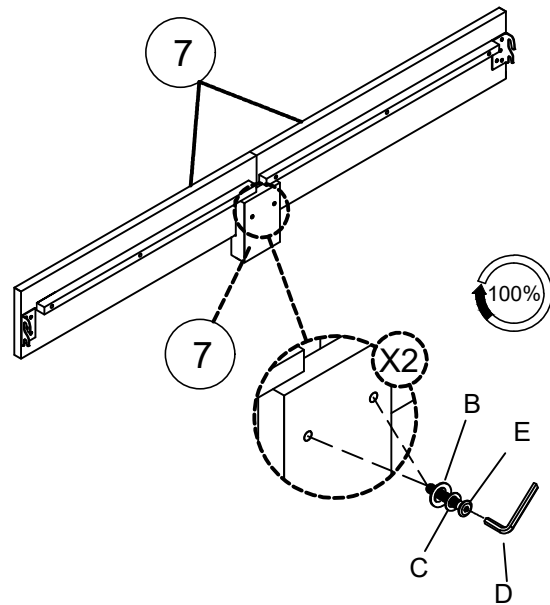
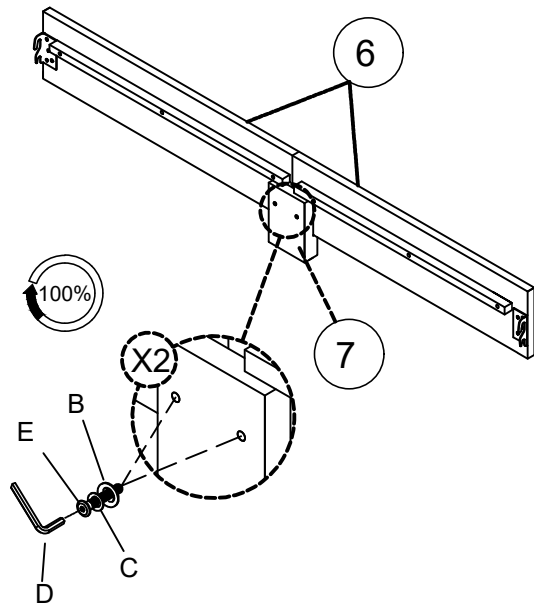

STEP 3

E x 4 	B x 4 	C x 4 	D x 1 
--	--	--	--



STEP 4

K x 4 	L x 2 
--	--

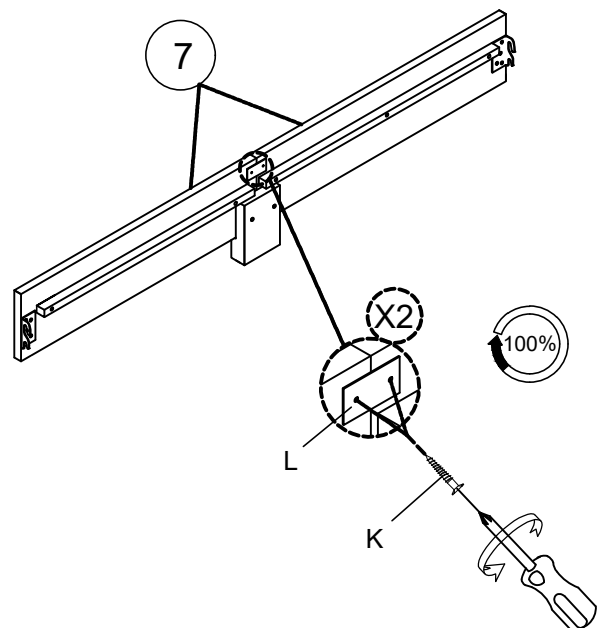
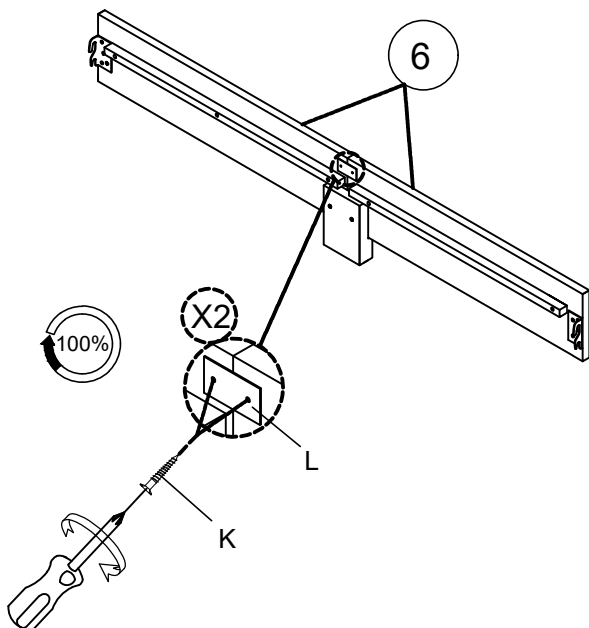

STEP 5

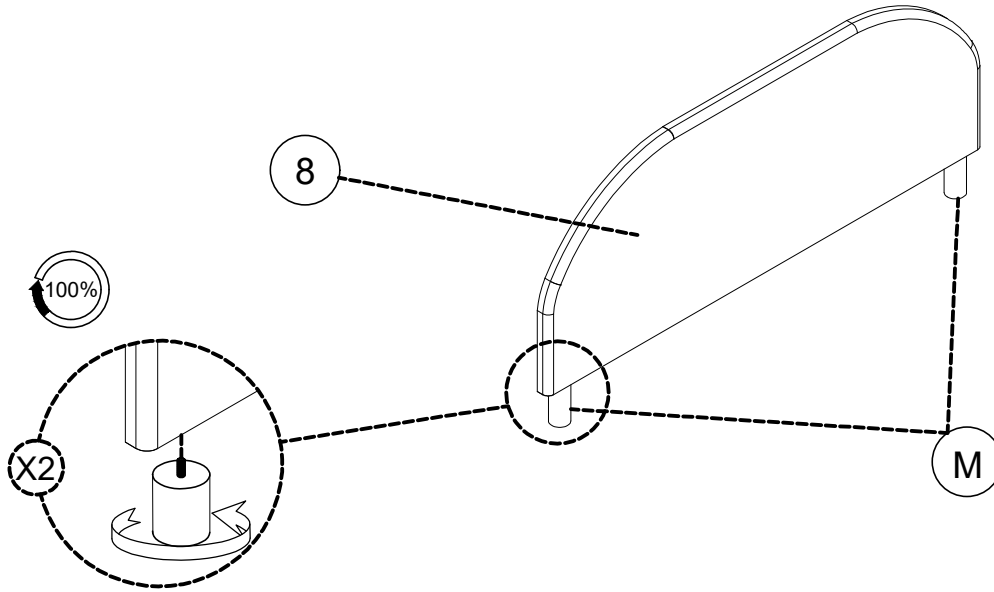
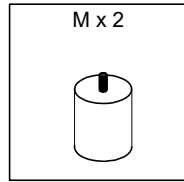

STEP 6

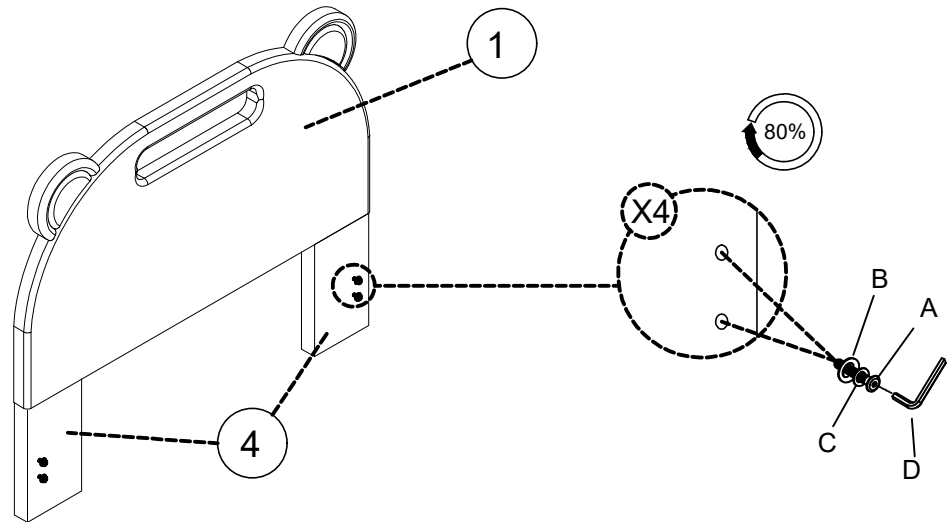
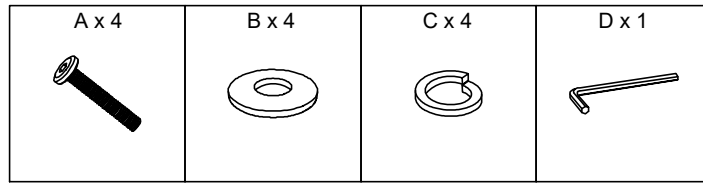

STEP 7

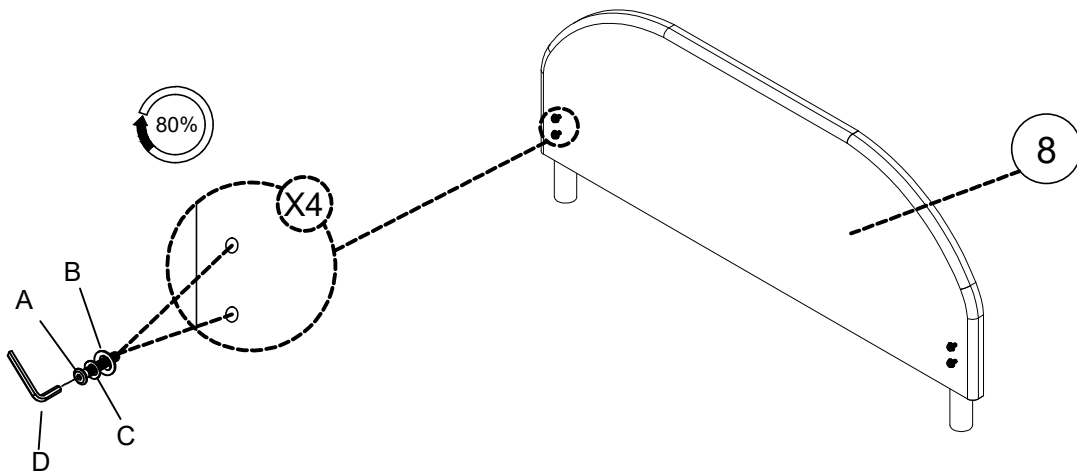
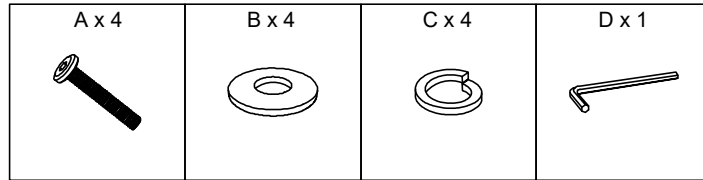

STEP 8

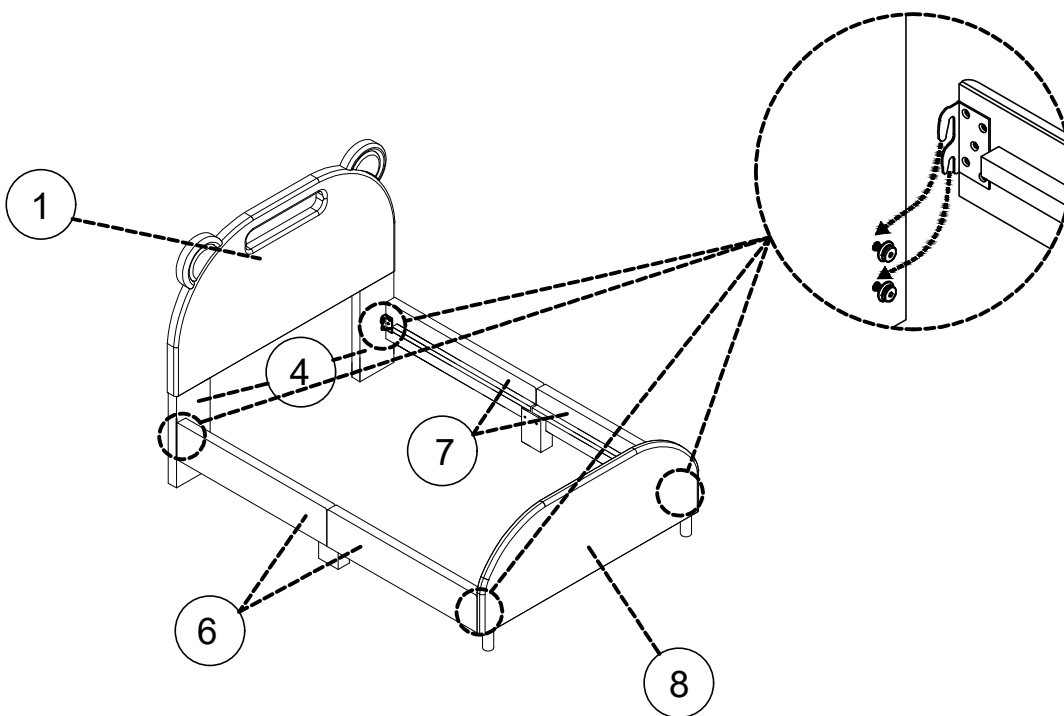

STEP 9

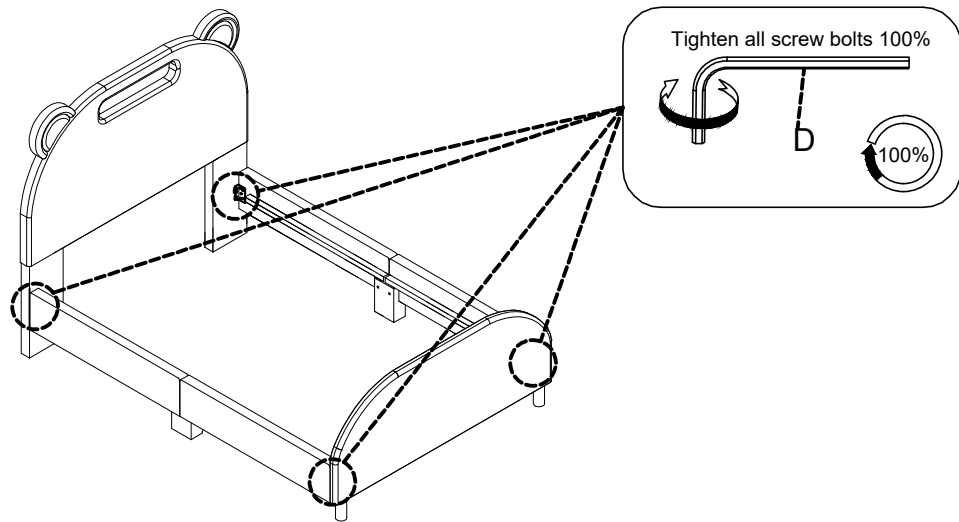

STEP 10

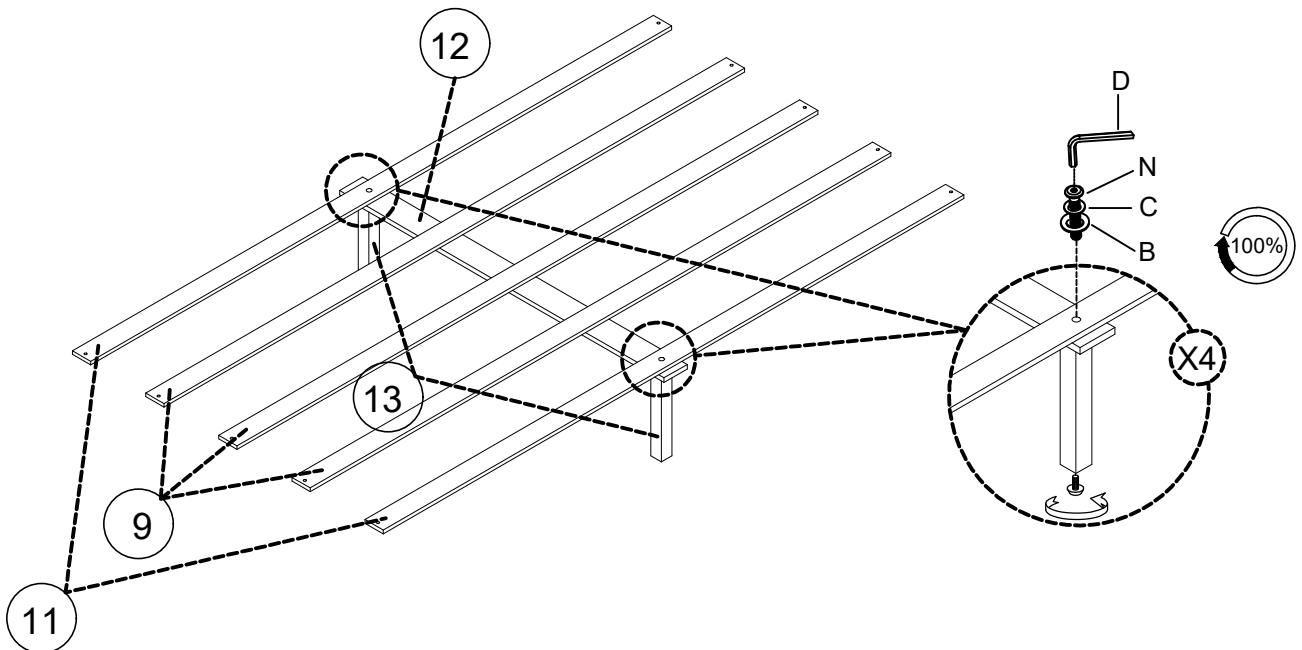
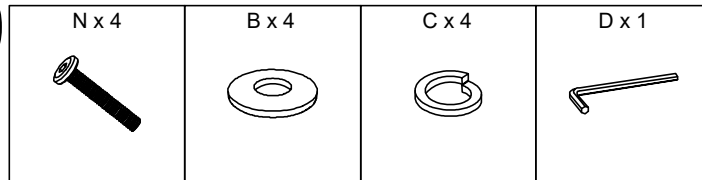

STEP 11

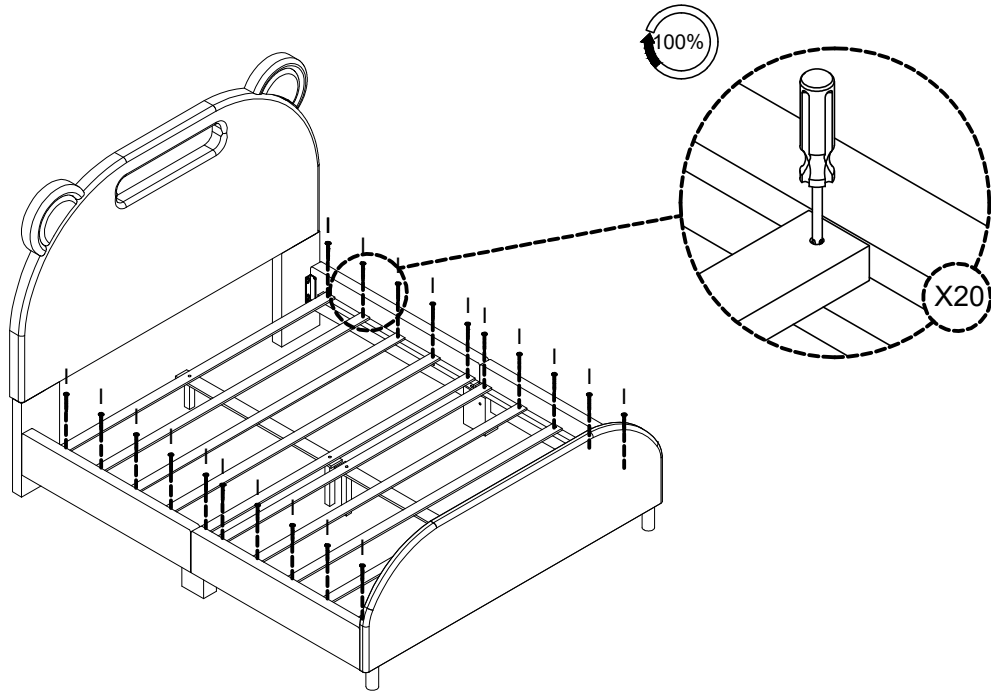
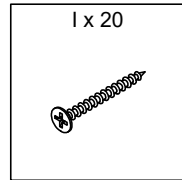

STEP 12

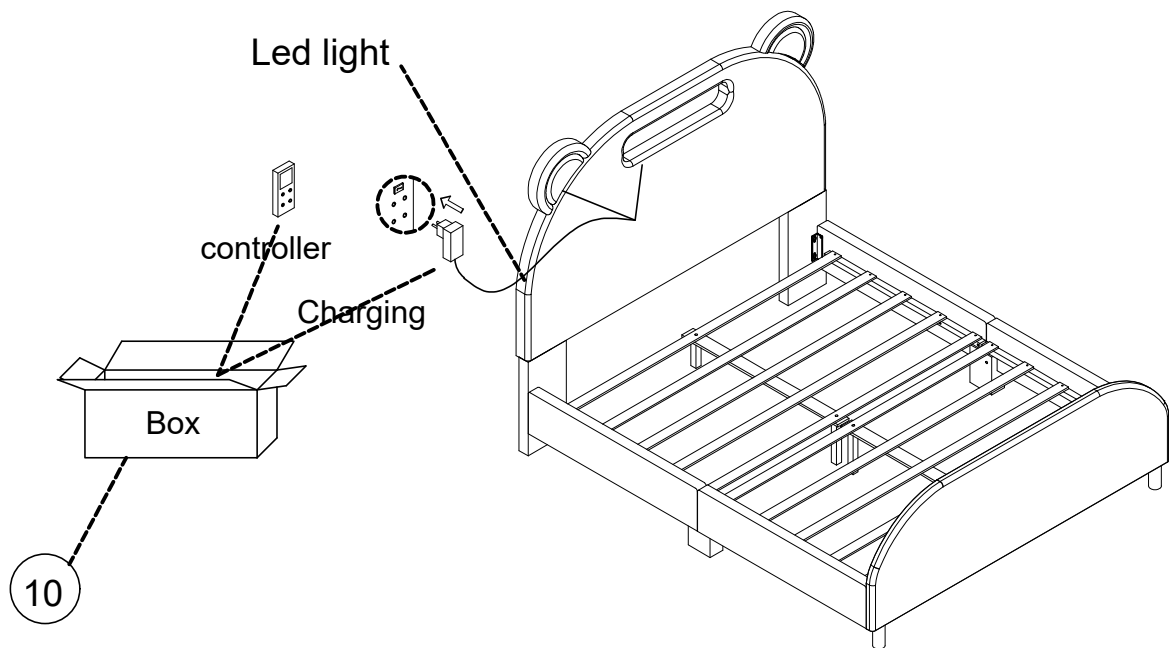
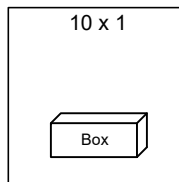

COMPLETE

