

ASSEMBLY INSTRUCTION

SKU CODE: (WF313259/WF313260)

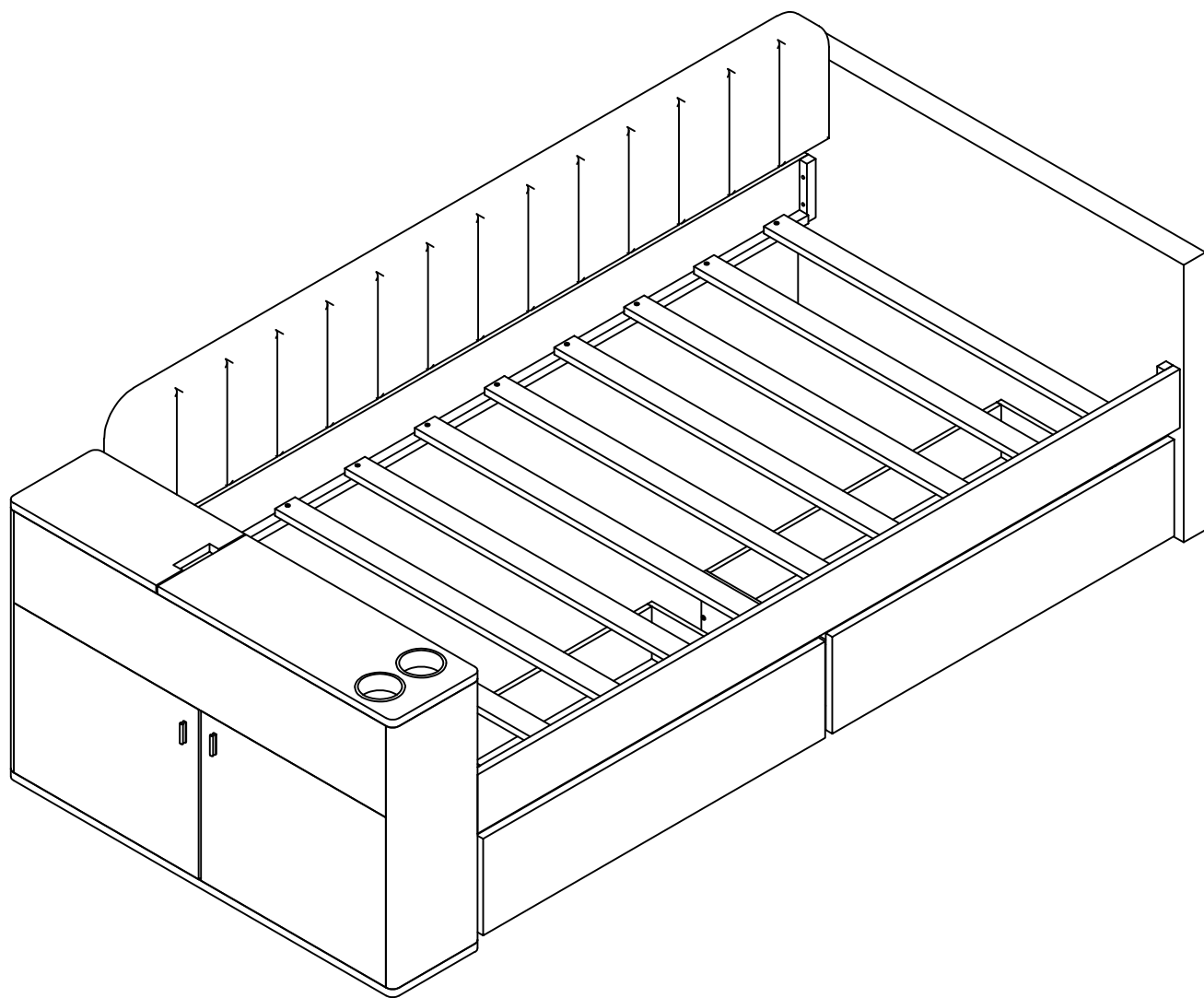

ASSEMBLY INSTRUCTION

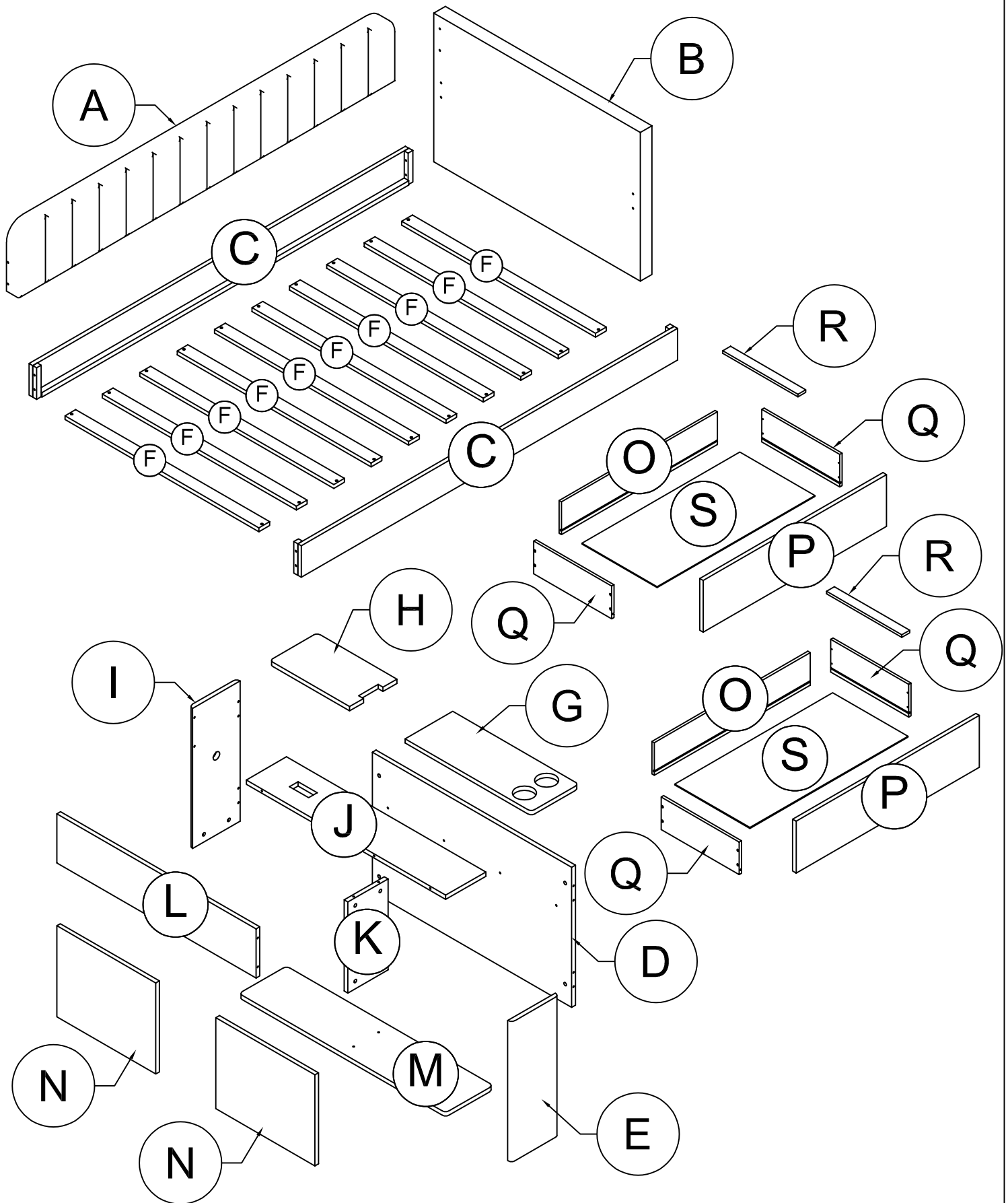



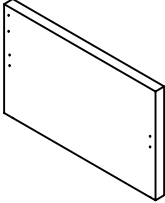
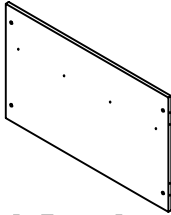
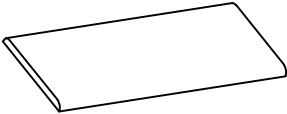
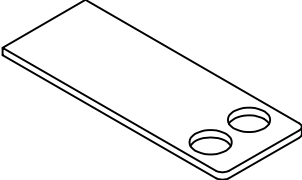
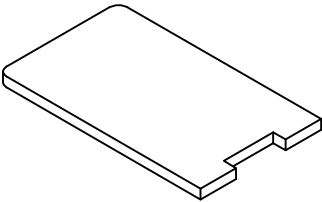
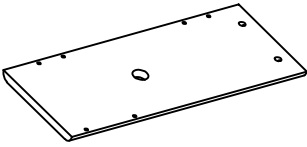
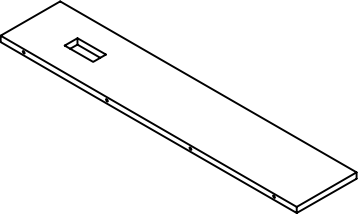
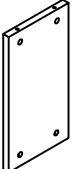
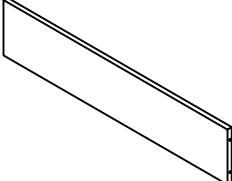
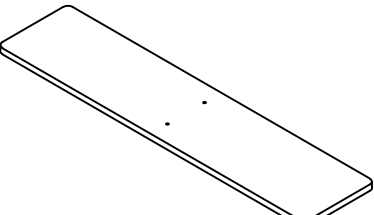
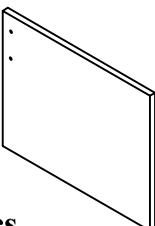



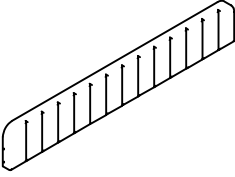
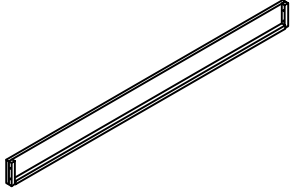
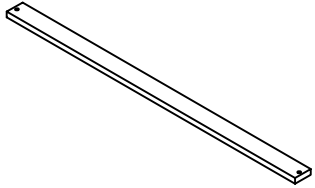
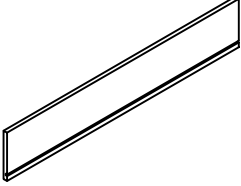
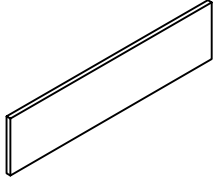
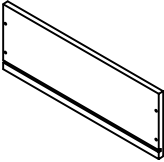
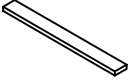
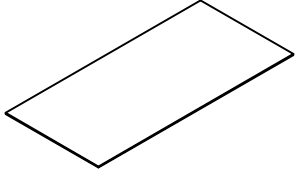

Part List (WF313259)

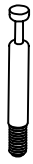
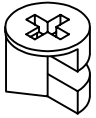
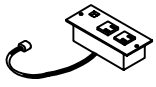
B  Right Arm - 1pc	D  Shelf - Back Panels - 1pc	E  Shelf - Right Side - 1pc
G  Shelf - Top Panels - 1pc	H  Shelf - Top Panels - 1pc	I  Shelf - Left Side - 1pc
J  Shelf - Large Surface - 1pc	K  Shelf - Back Panels - 1pc	L  Shelf - Front Panels - 1pc
M  Shelf - Middel Panels - 1pc	N  Doors - 2pcs	

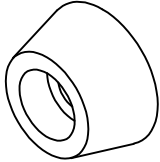
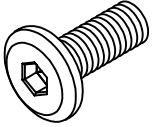
Part List (WF313260)

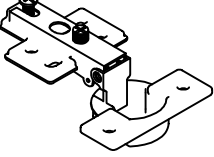
A  Back Panels- 1pcs	C  Side Rails - 2 pcs	F  Slats - 10 pcs
O  Drawers - Back Panel - 2pcs	P  Drawers - Front Panel - 2 pcs	Q  Drawers - Side Panel - 4 pcs
R  Trundle front - 2 pcs	S  Drawer - Bottom Panel- 2 pcs	

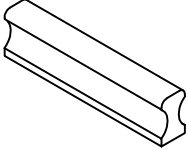
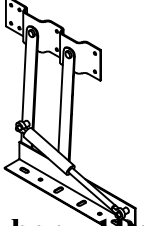
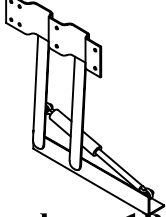
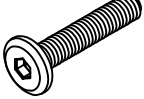
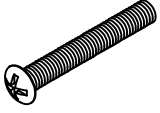
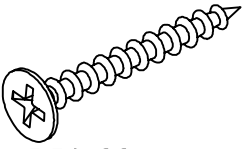
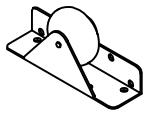
Hardware List (WF313260)

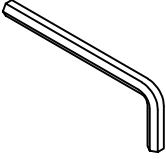
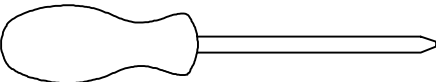
<p>1</p>  <p>Link 1 -24Pcs</p>	<p>2</p>  <p>Link 2 -24Pcs</p>	<p>3</p>  <p>power outlet-1Pcs</p>
<p>4</p>  <p>M4x15 Wood Screw - 46 Pcs</p>	<p>5</p>  <p>plastic foot sole-7Pcs</p>	<p>6</p>  <p>Ø1/4x15mm Hex head bolt - 7 Pcs</p>
<p>7</p>  <p>hinge screw - 12Pcs</p>	<p>8</p>  <p>Hinge - 6Pcs</p>	<p>9</p>  <p>Ø8x30 wooden pegs-4Pcs</p>
<p>10</p>  <p>Glass - 2Pcs</p>	<p>11</p>  <p>Holder - 2Pcs</p>	<p>12</p>  <p>Right lifting ben - 1Pcs</p>
<p>13</p>  <p>Left lifting ben - 1Pcs</p>	<p>14</p>  <p>Ø1/4x35mm Hex head bolt - 12 Pcs</p>	<p>15</p>  <p>Ø5/32 x 30mm bolt - 4 Pcs</p>
<p>16</p>  <p>M4x30 Wood Screw - 36 Pcs</p>	<p>17</p>  <p>wheels - 8 Pcs</p>	<p>18</p>  <p>plastic drawer stopper - 4 Pcs</p>
<p>19</p>  <p>Allen key - 1 Pcs</p>		

Assembly Tools Required (Not Included)

STEP 1: Following below illustration:

1	
24 Pcs	

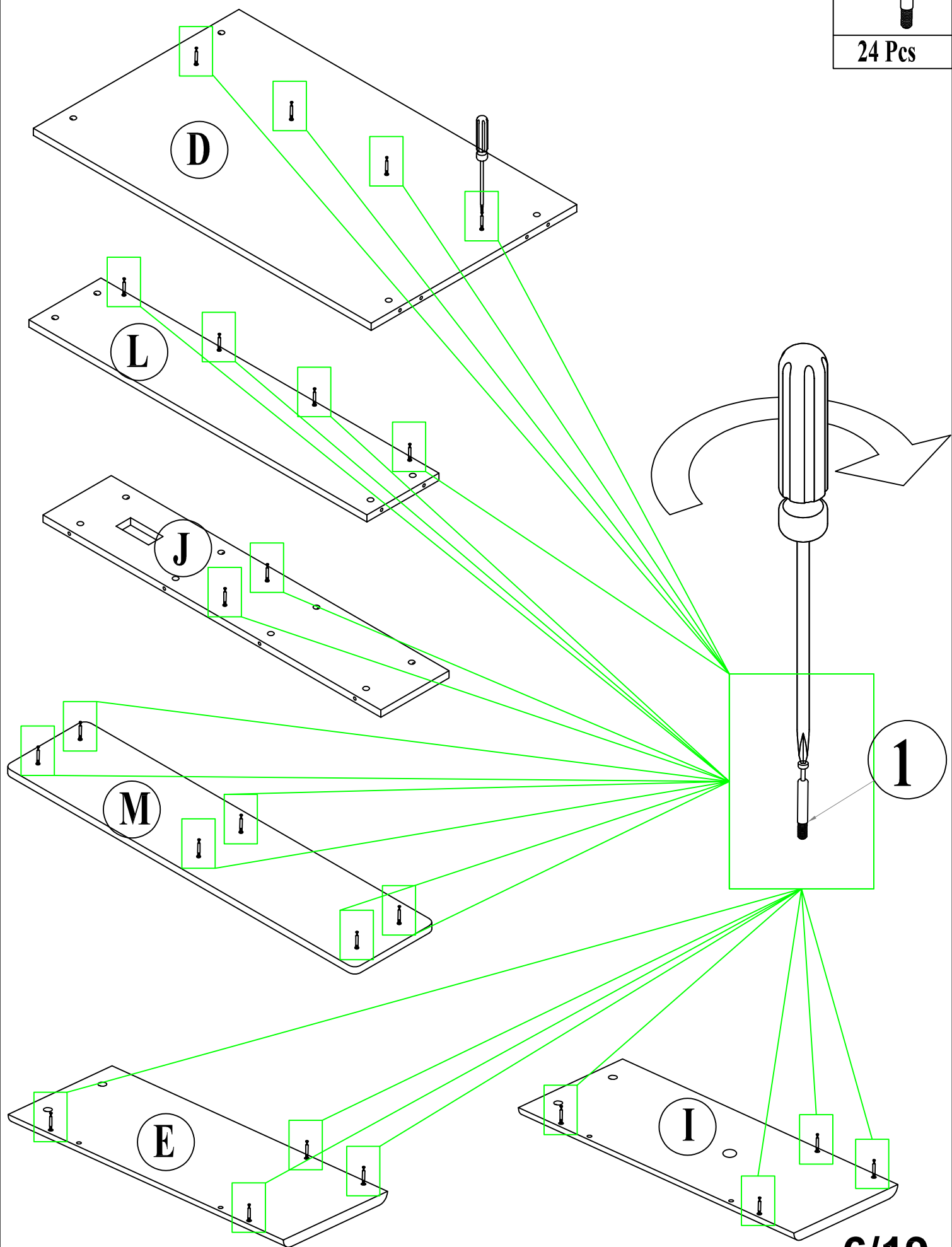

STEP 2-1: Following below illustration:

2

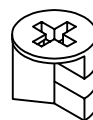

2 Pcs

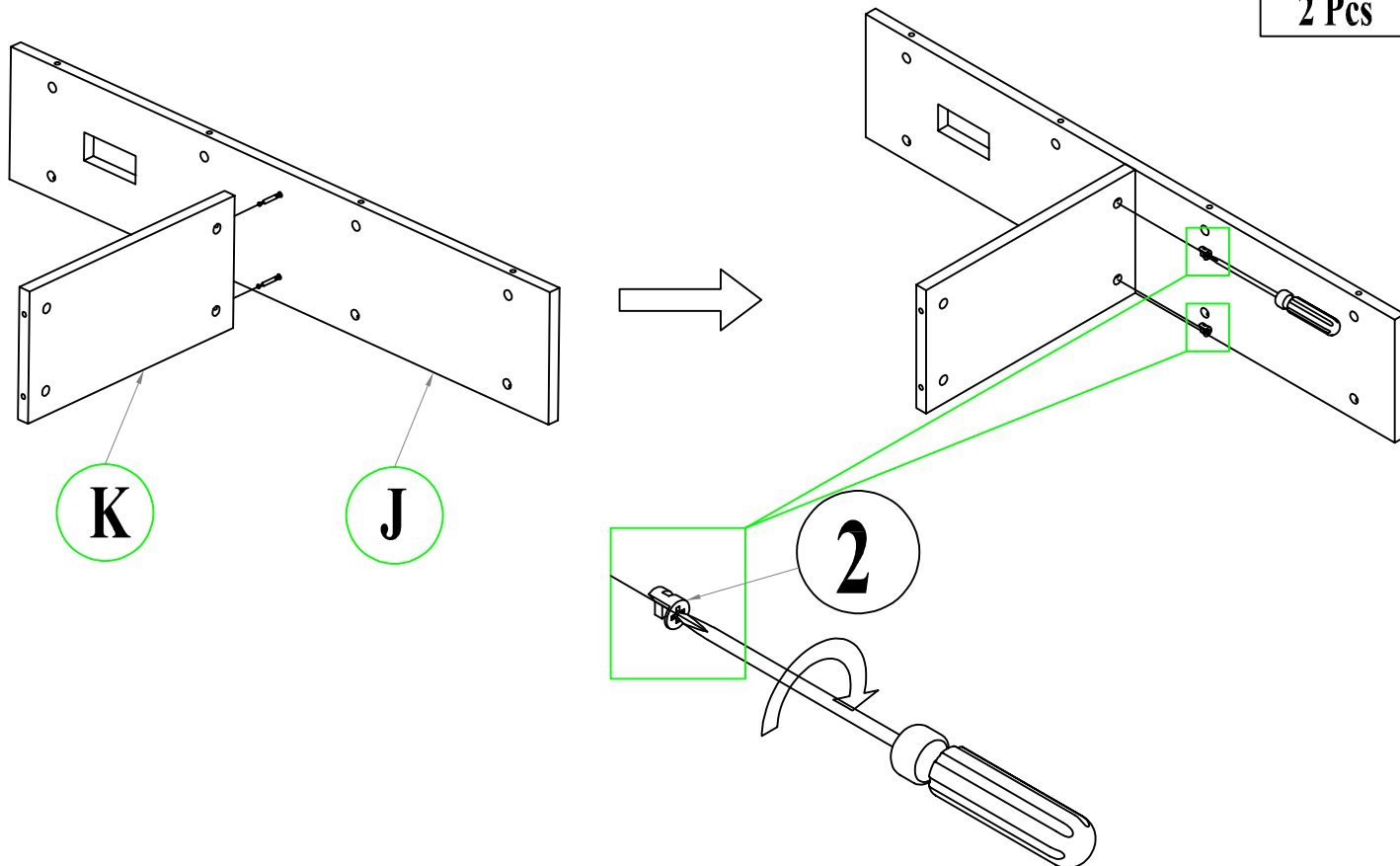

STEP 2-2: Following below illustration:

2

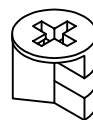

4 Pcs

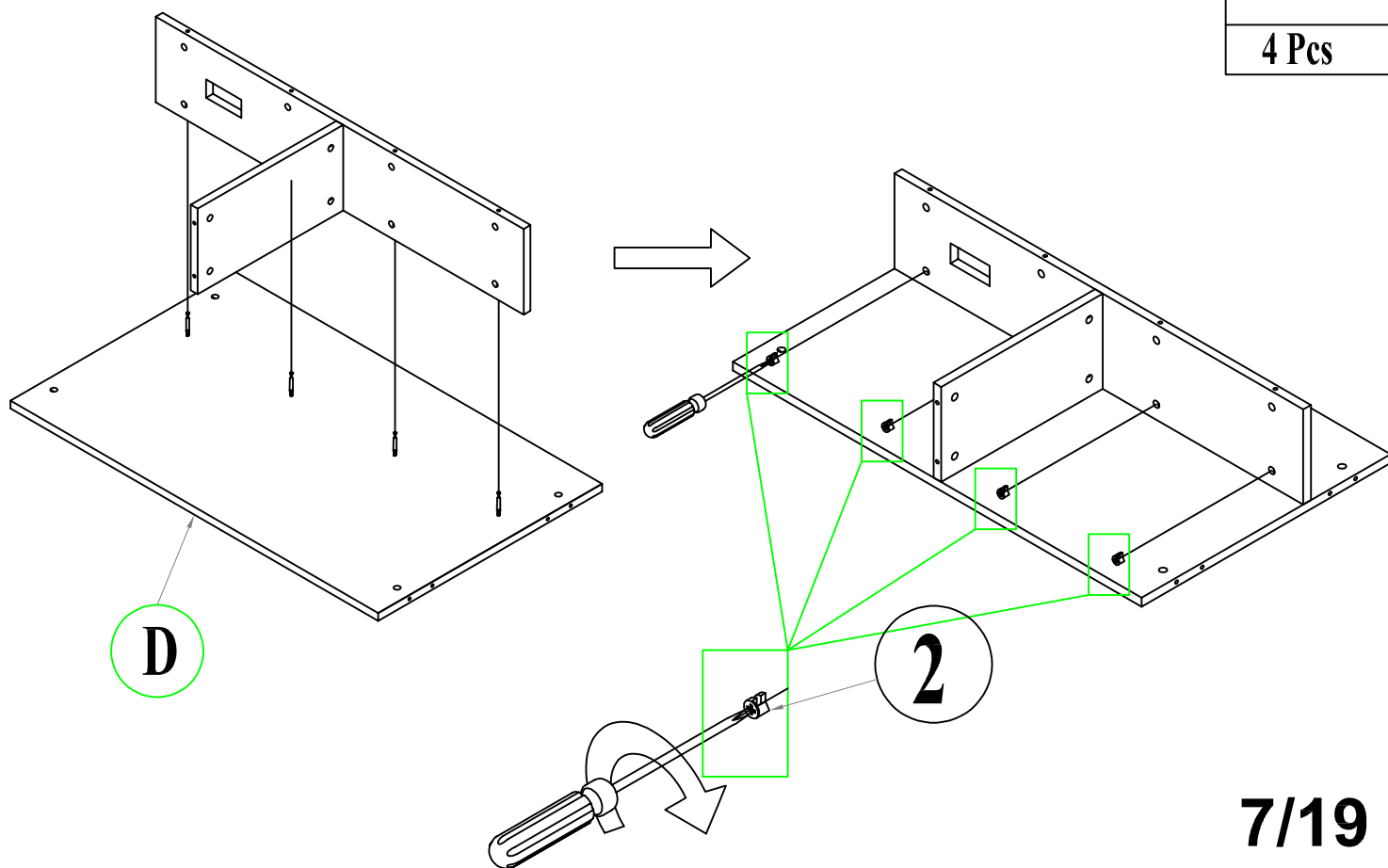

STEP 2-3: Following below illustration:

2



4 Pcs

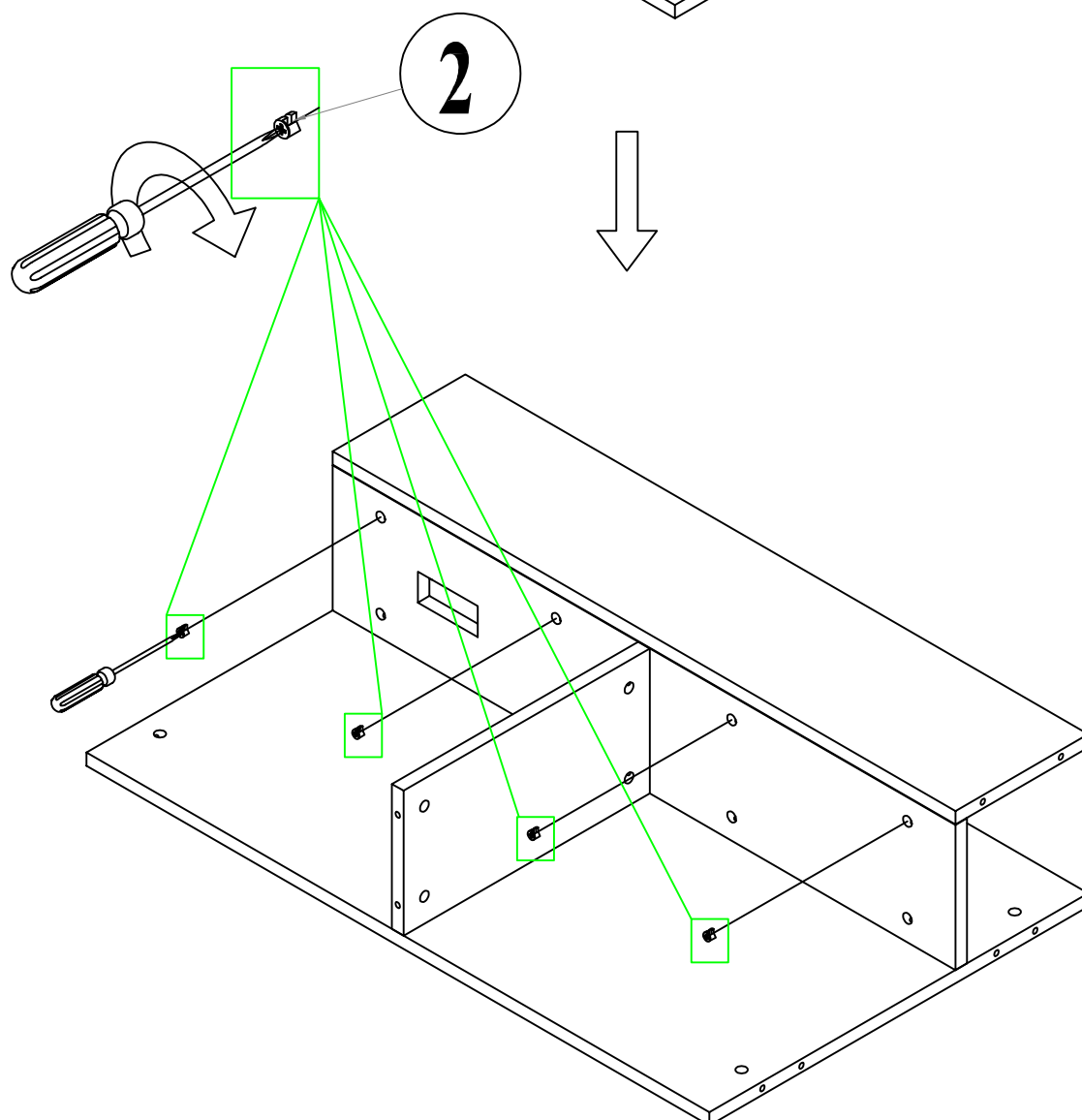
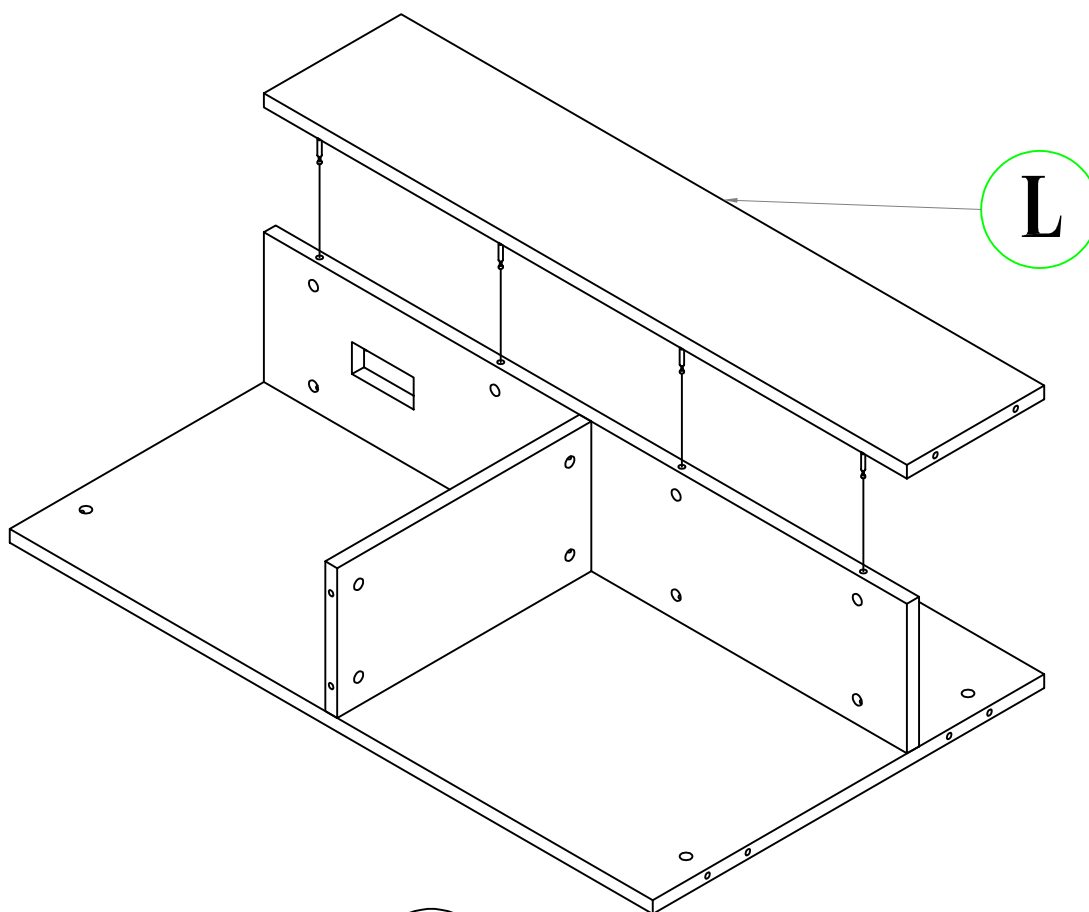

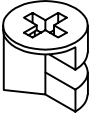

STEP 2-4: Following below illustration:

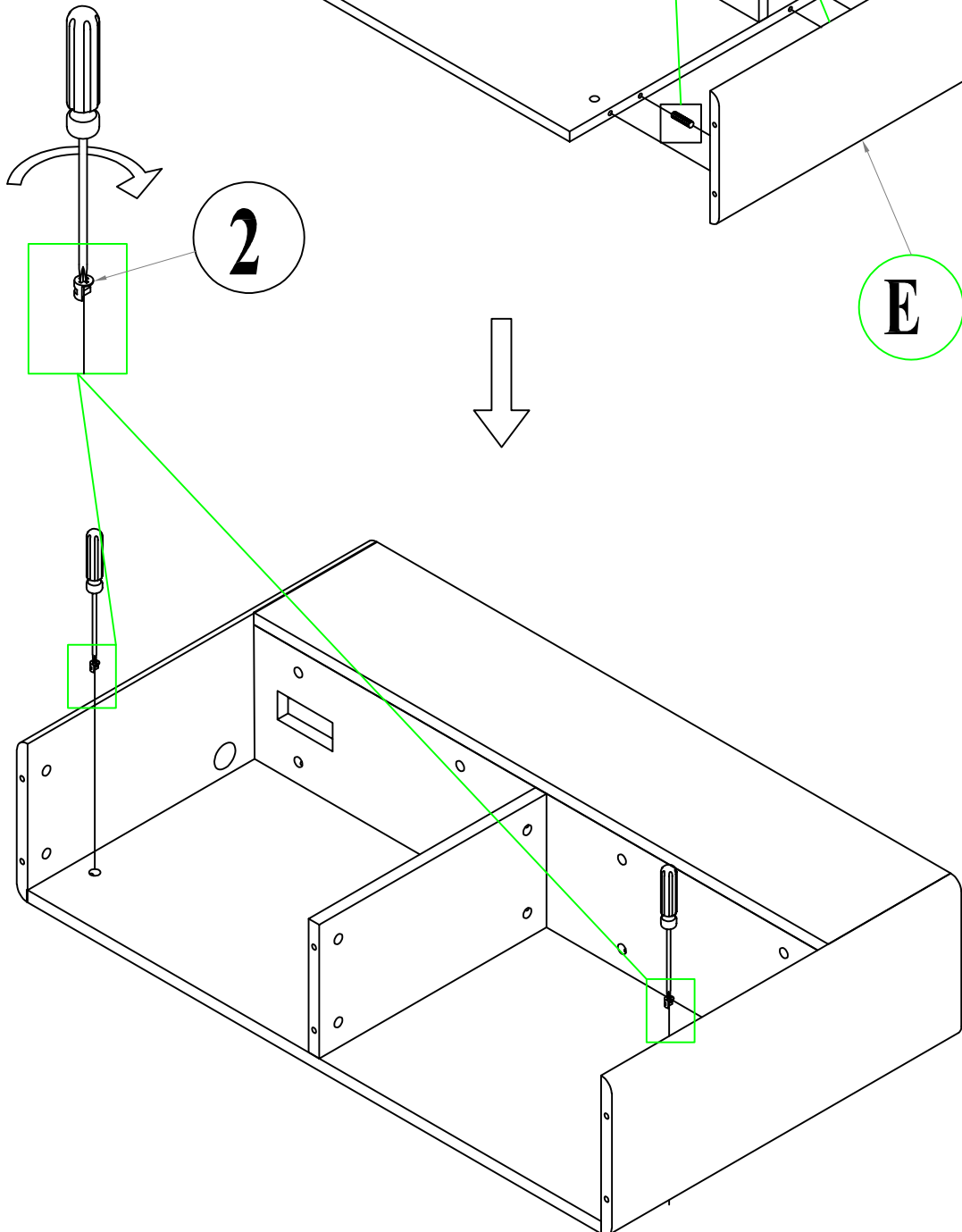
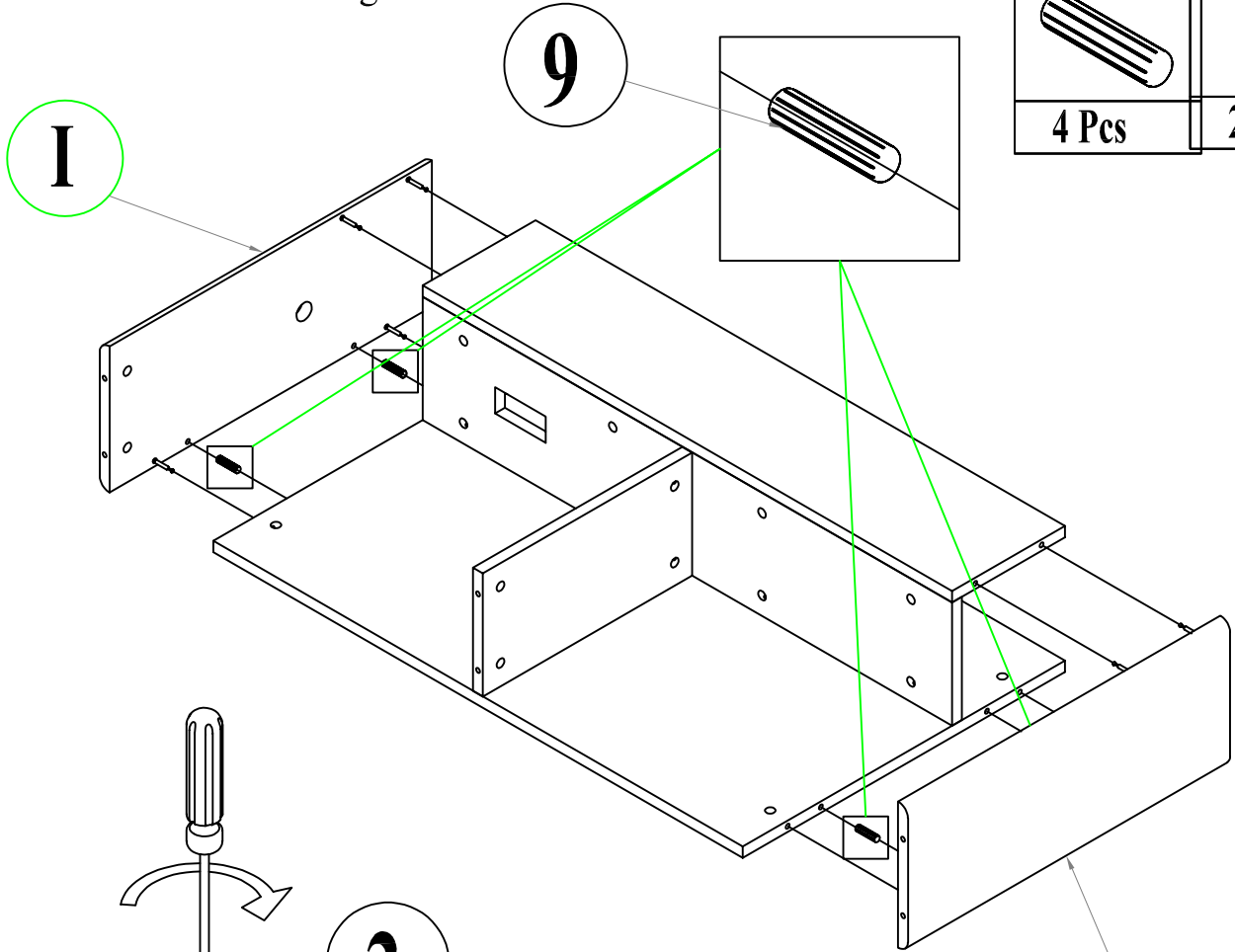
9 	2 
4 Pcs	2 Pcs

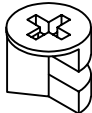

STEP 2-5: Following below illustration:

2		3		4	
6 Pcs		1 Pcs		2 Pcs	

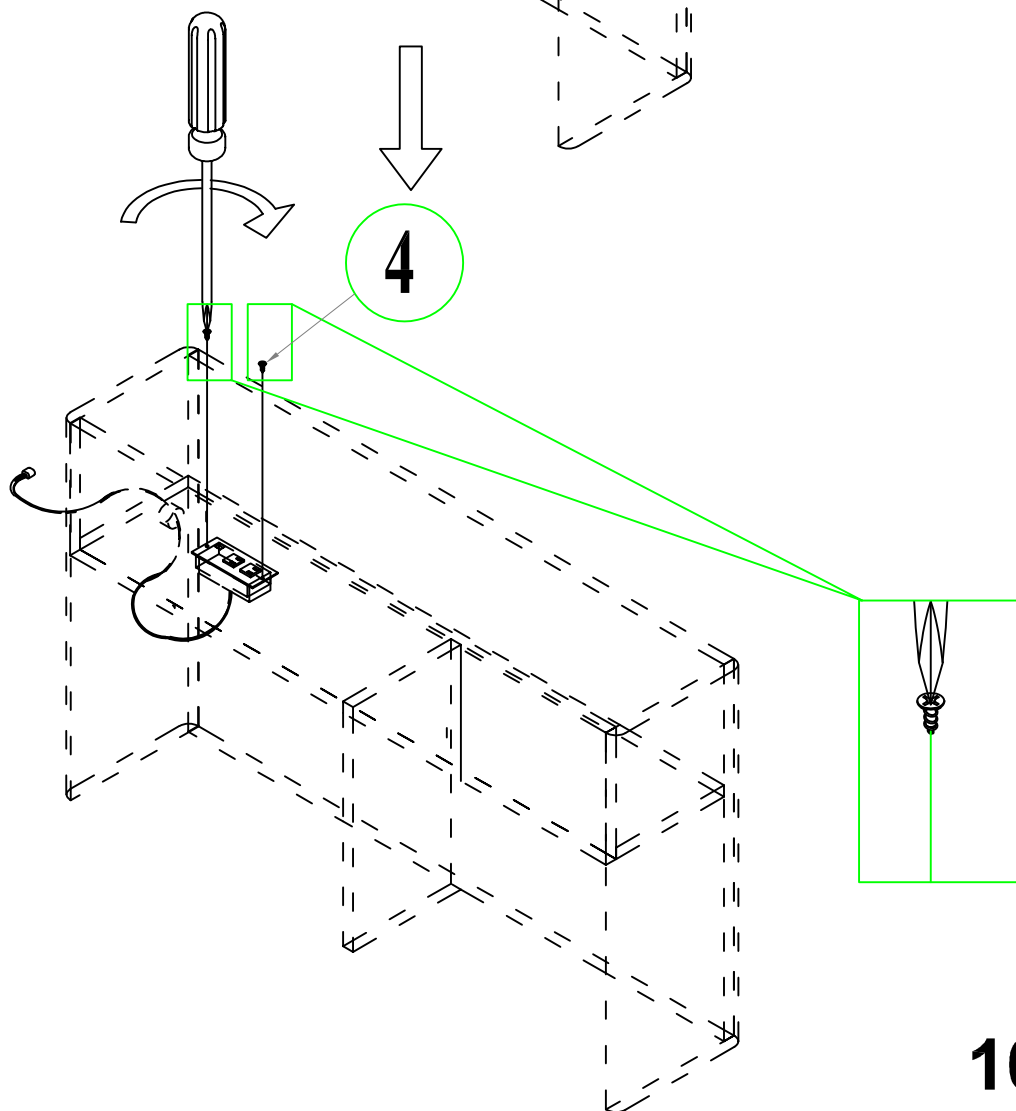
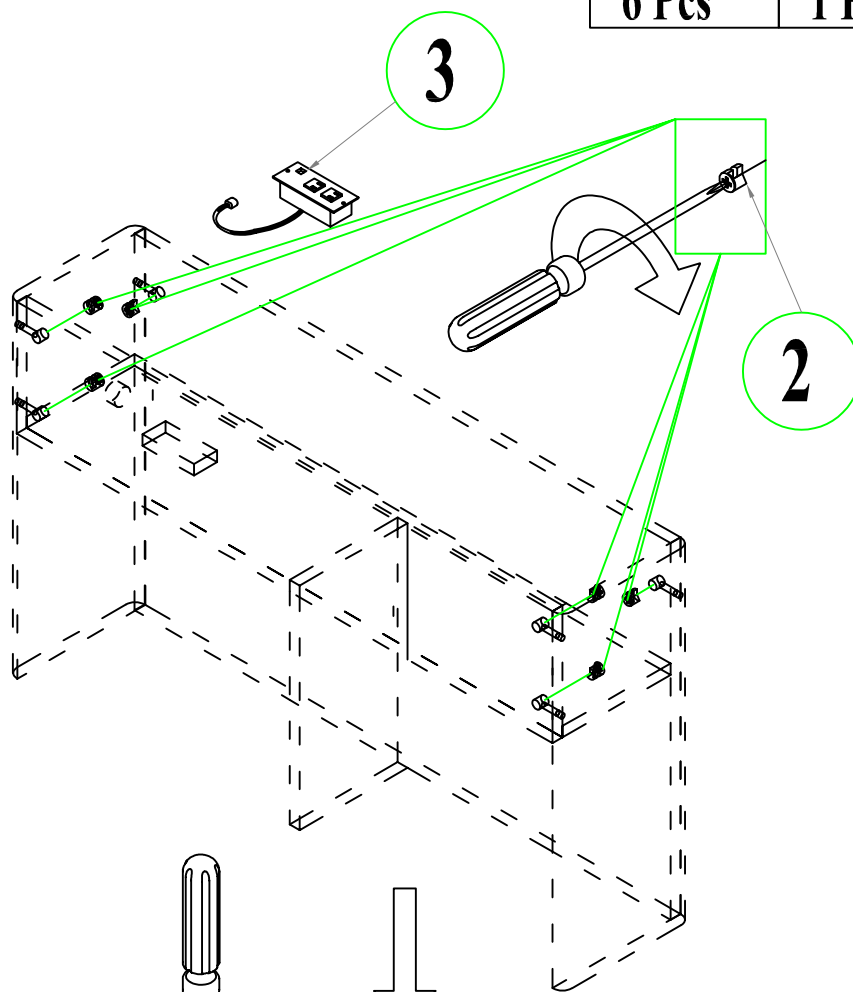



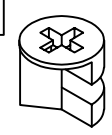
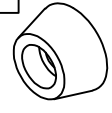
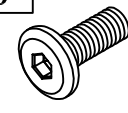

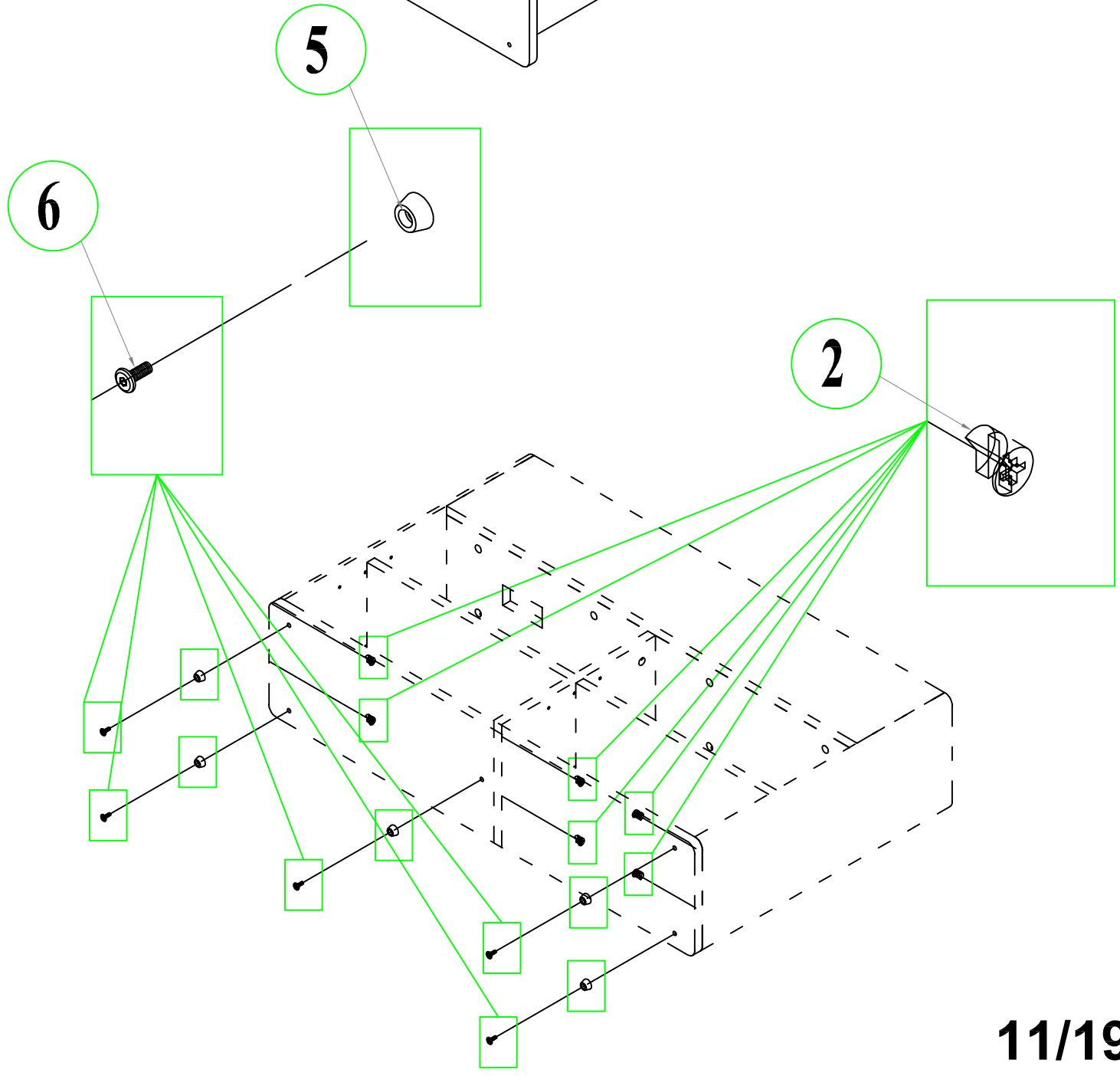
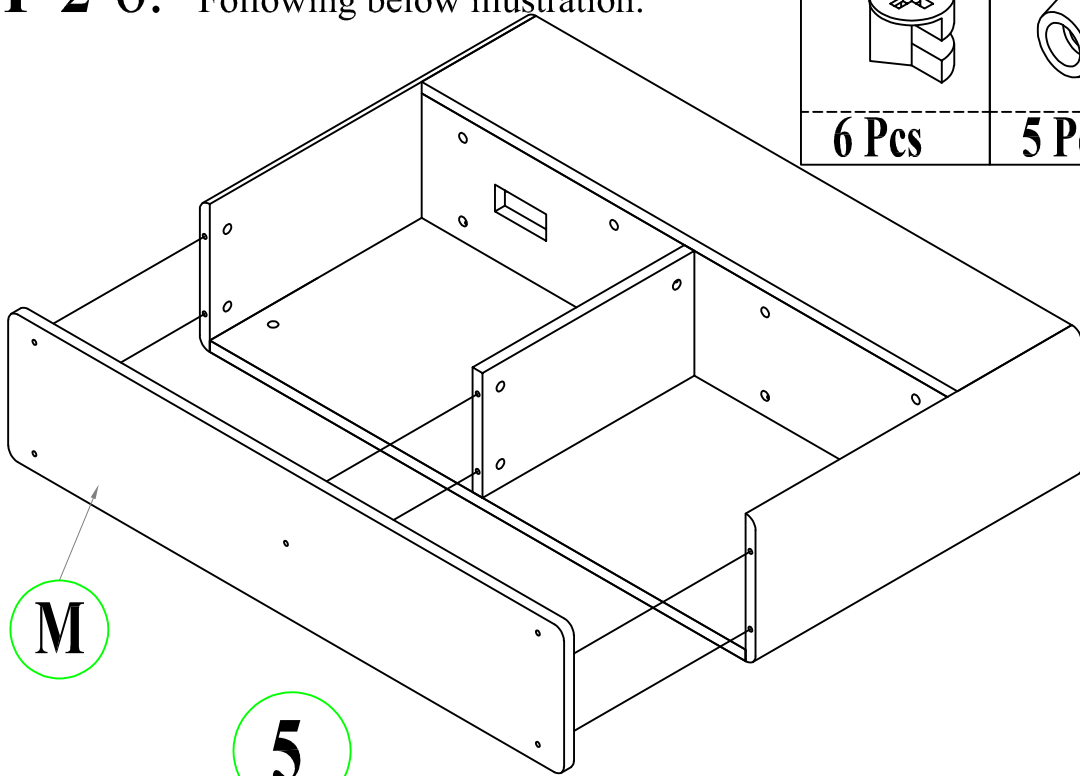
STEP 2-6: Following below illustration:

2		5		6	
6 Pcs		5 Pcs		5 Pcs	

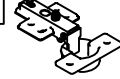
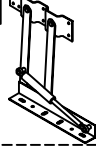

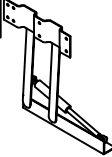

STEP 2-7: Following below illustration:

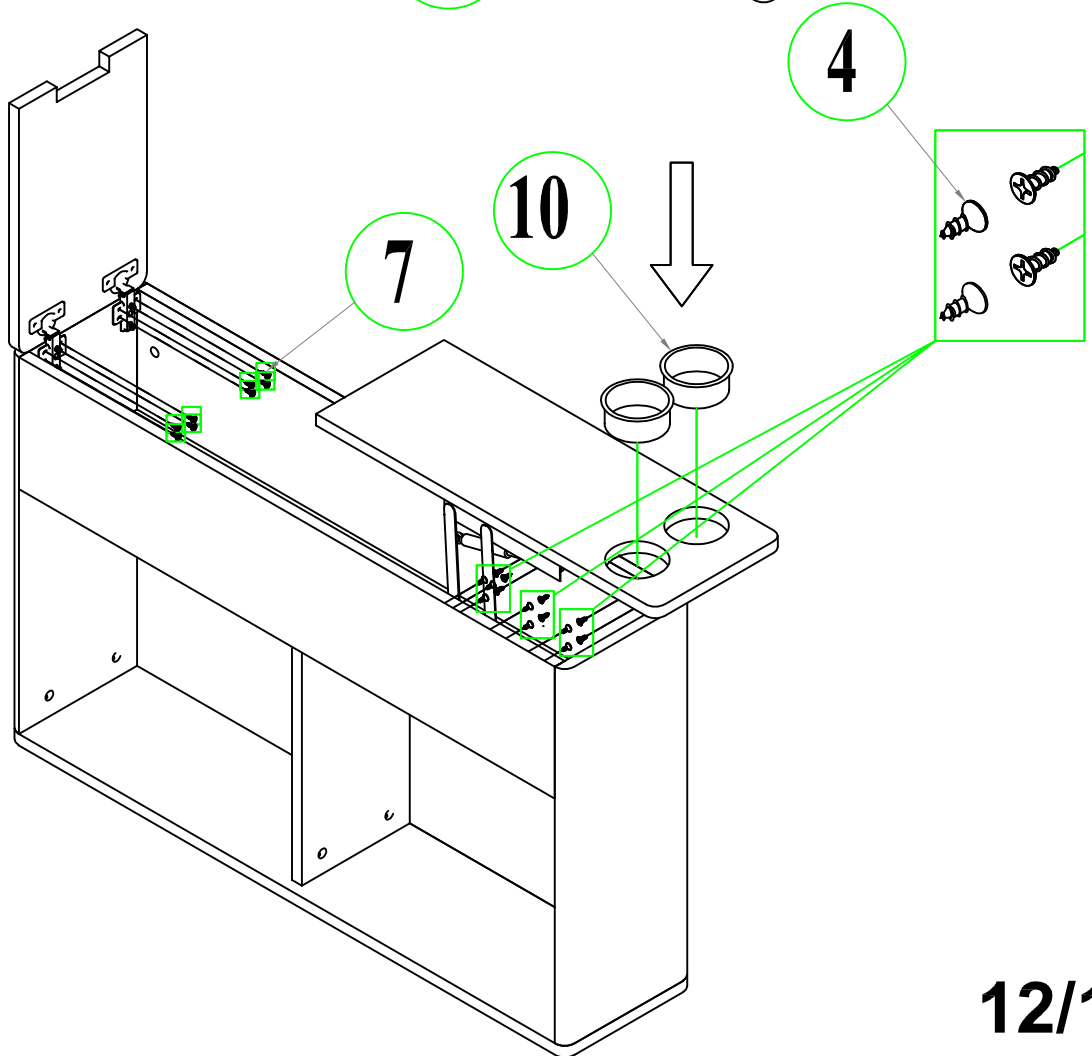
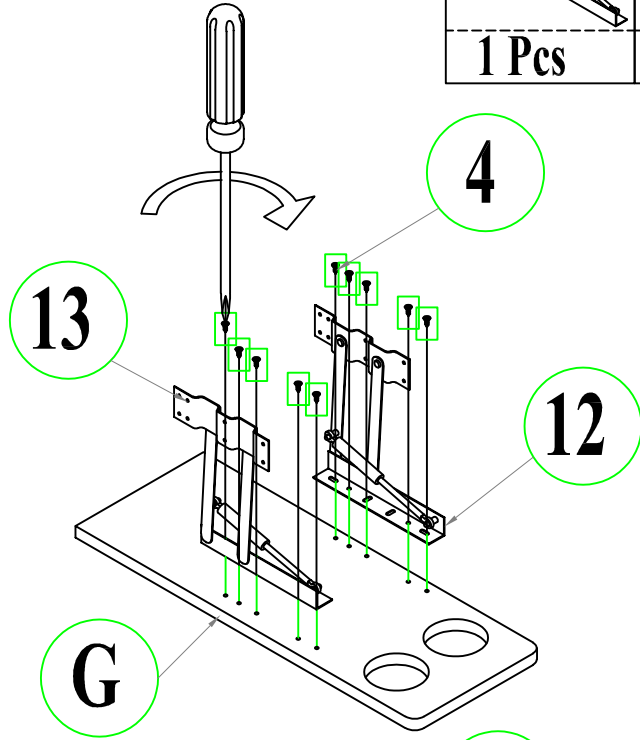
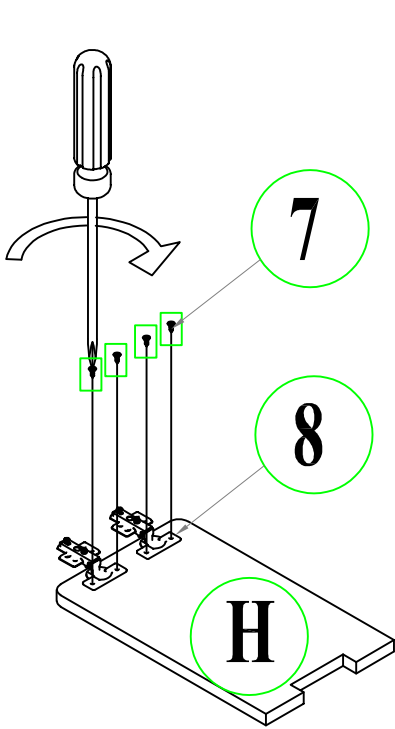
7 	8 	12 	10 
12 Pcs	2 Pcs	1 Pcs	2 Pcs
13 			4 
1 Pcs			24 Pcs

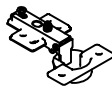

STEP 2-8: Following below illustration:

7		8		11		15	
24 Pcs		4 Pcs		24 Pcs		4 Pcs	

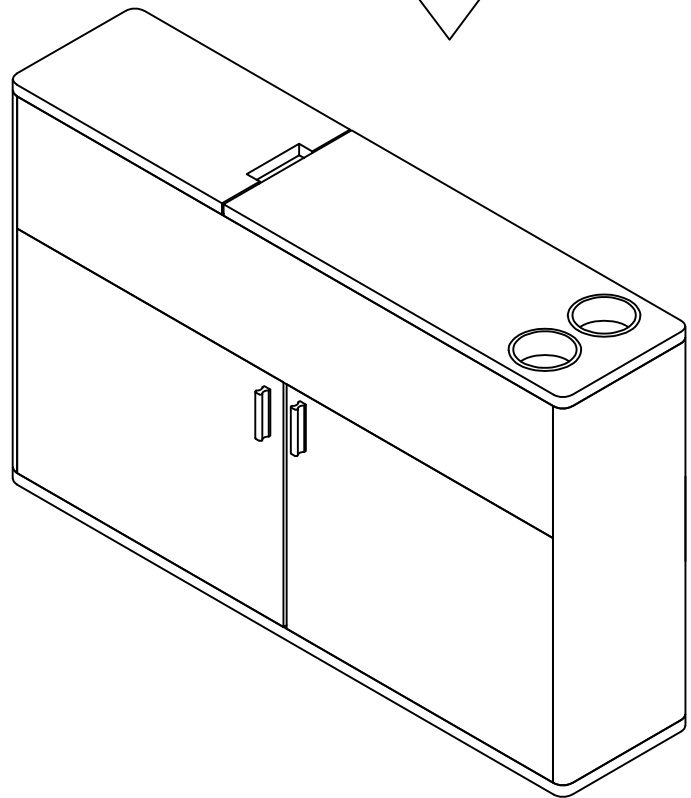
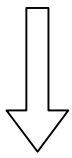
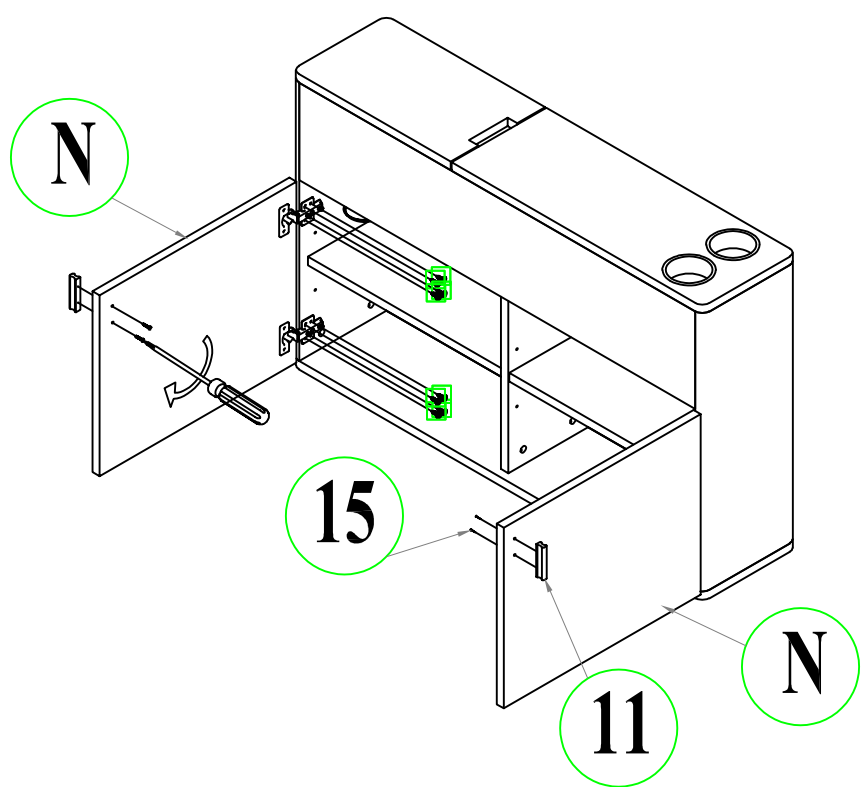
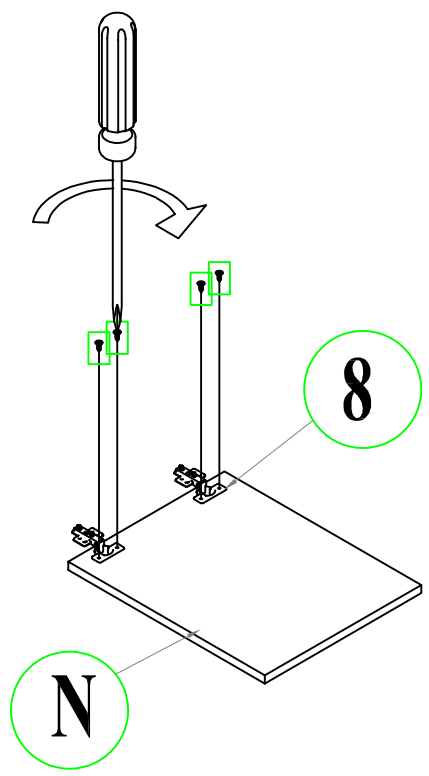

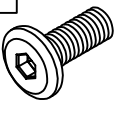

STEP 3: Following below illustration:

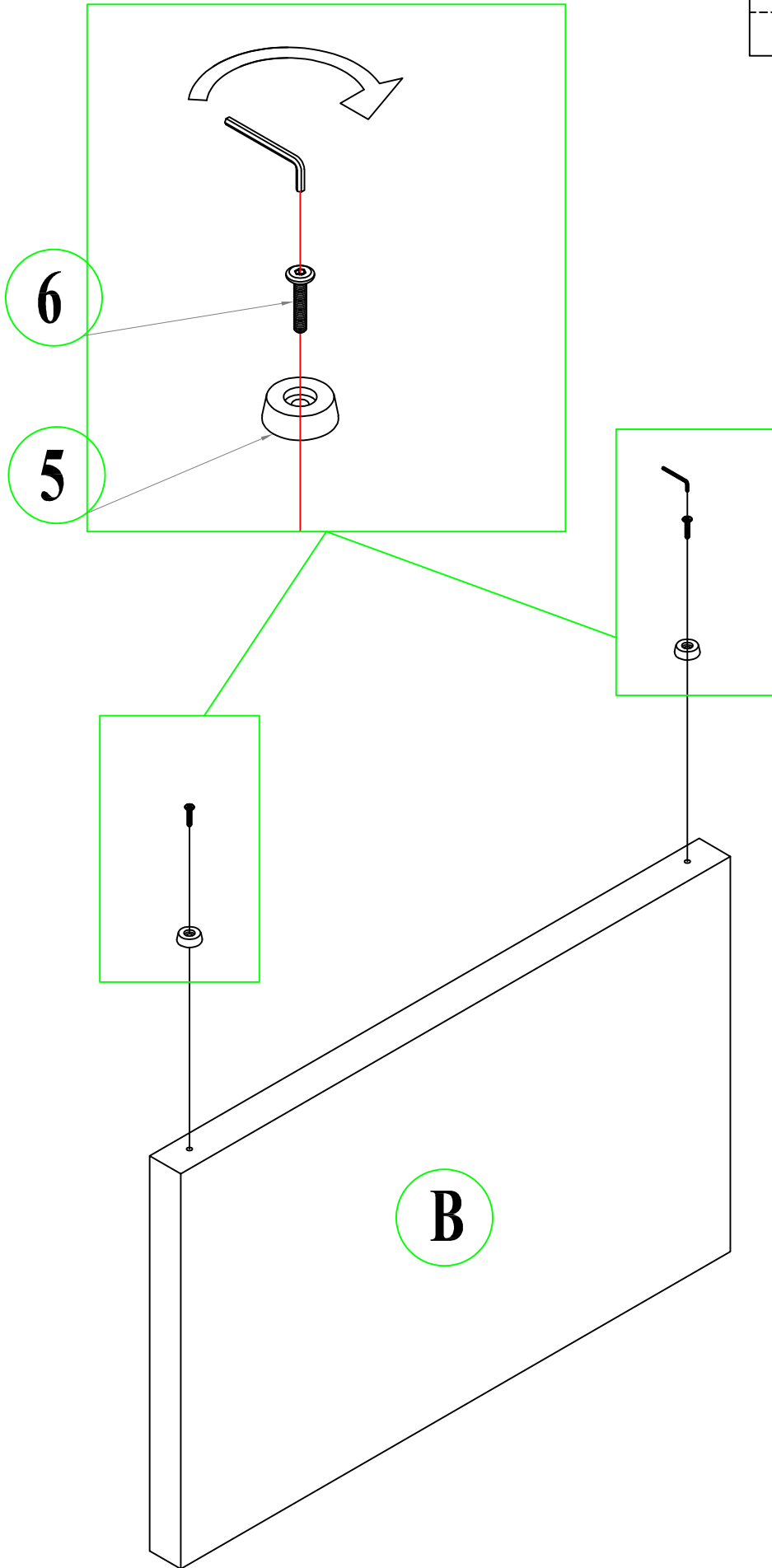
5	6
	
2 Pcs	2 Pcs

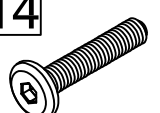

STEP 4: Following below illustration:

3		4		14	
4 Pcs		4 Pcs		8 Pcs	

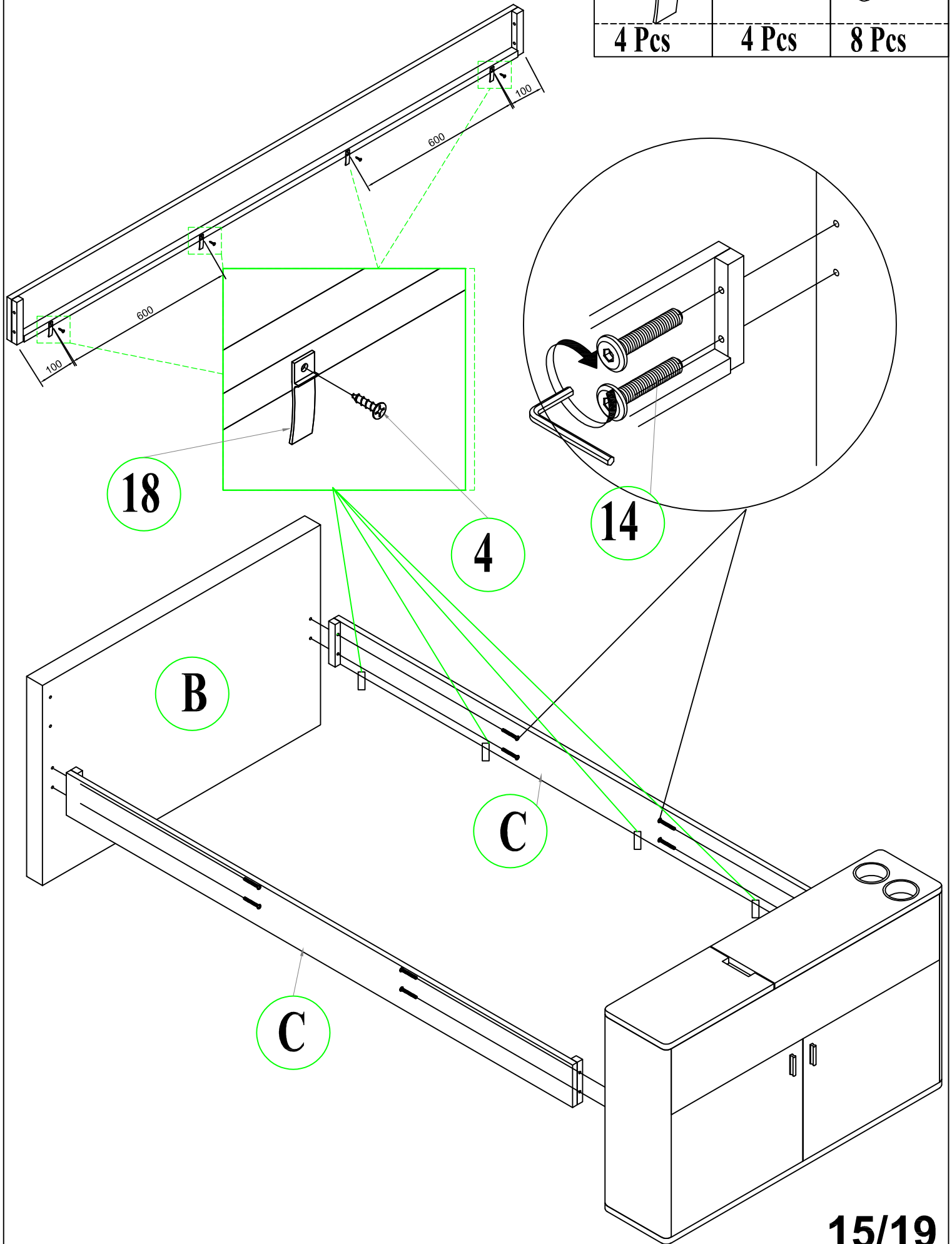

STEP 5: Following below illustration:

16



20 Pcs

14

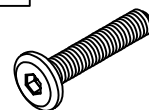

4 Pcs

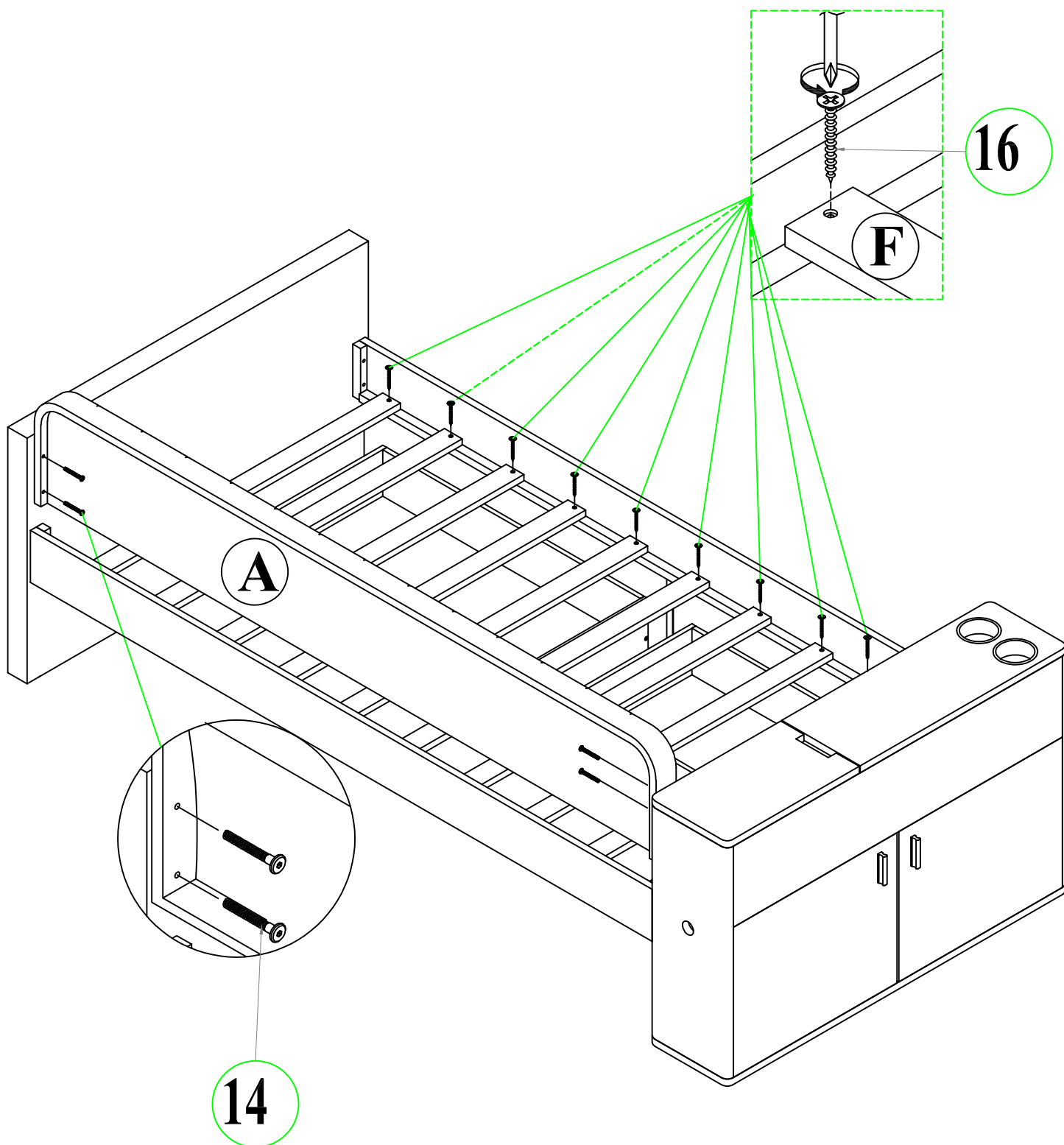

STEP 6: Following below illustration:

16



8 Pcs

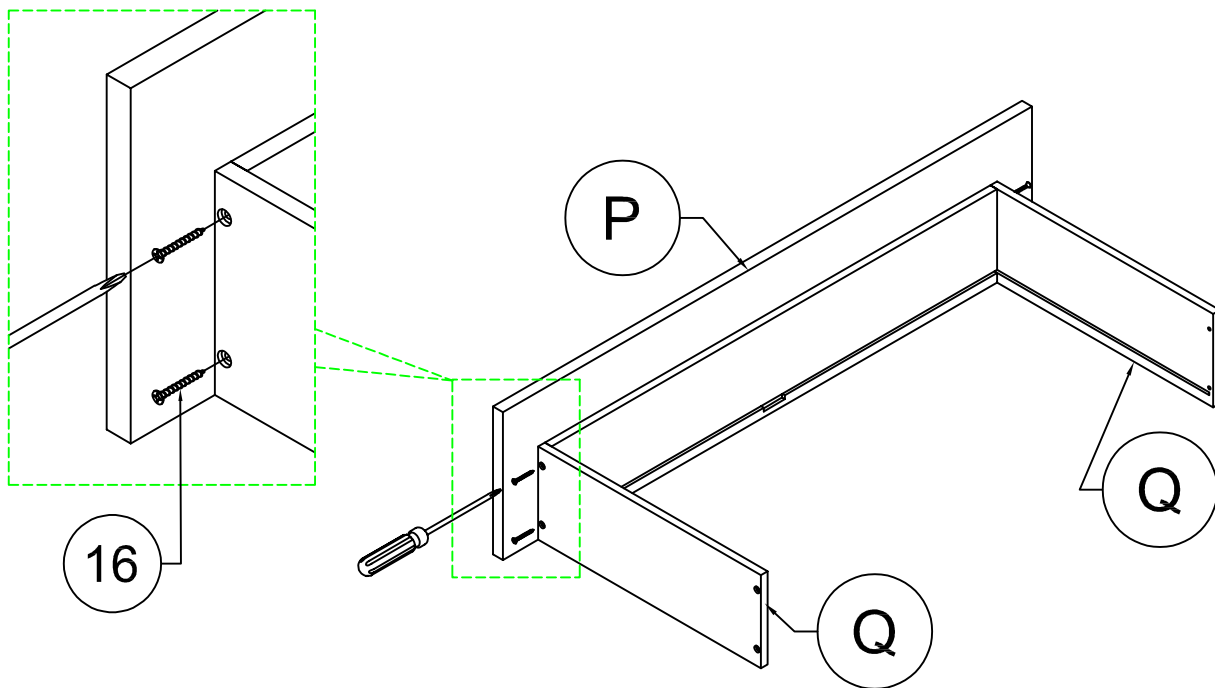

X2

STEP 6-1: Following below illustration:

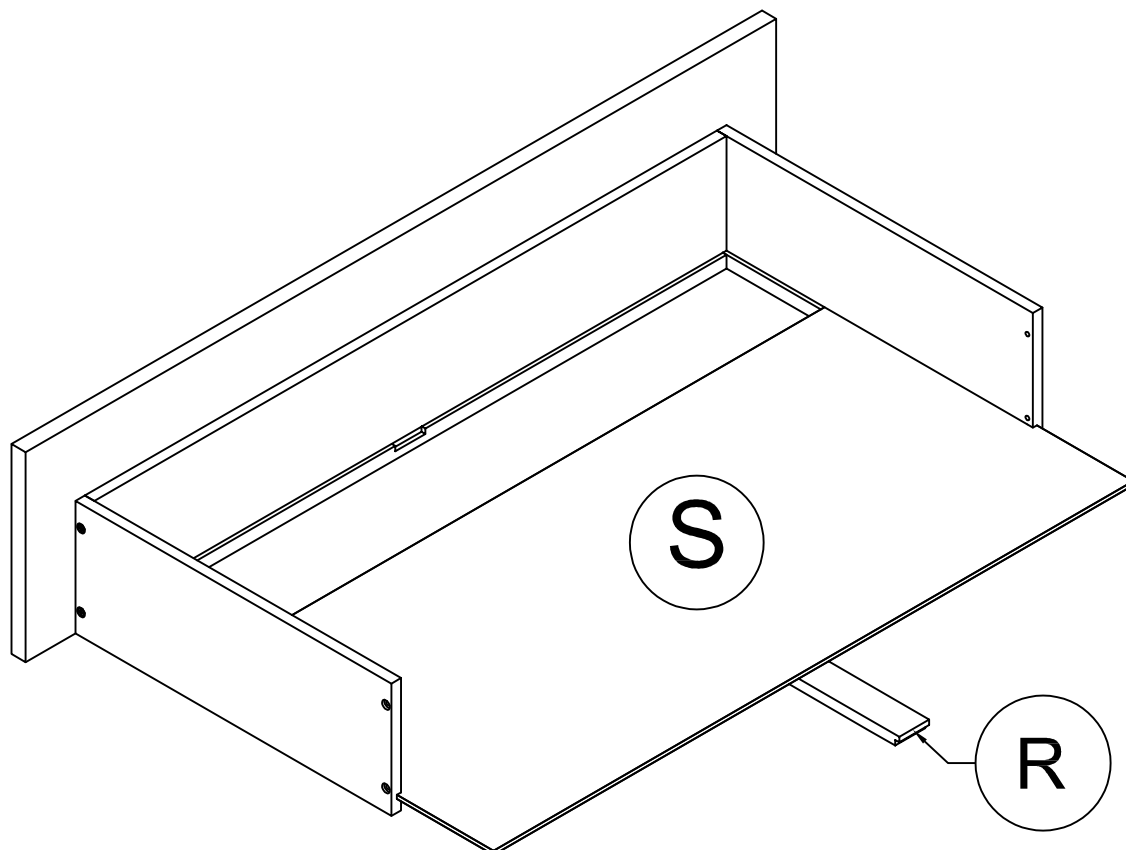

X2

17/19

STEP 7: Following below illustration:

16



8 Pcs

X2

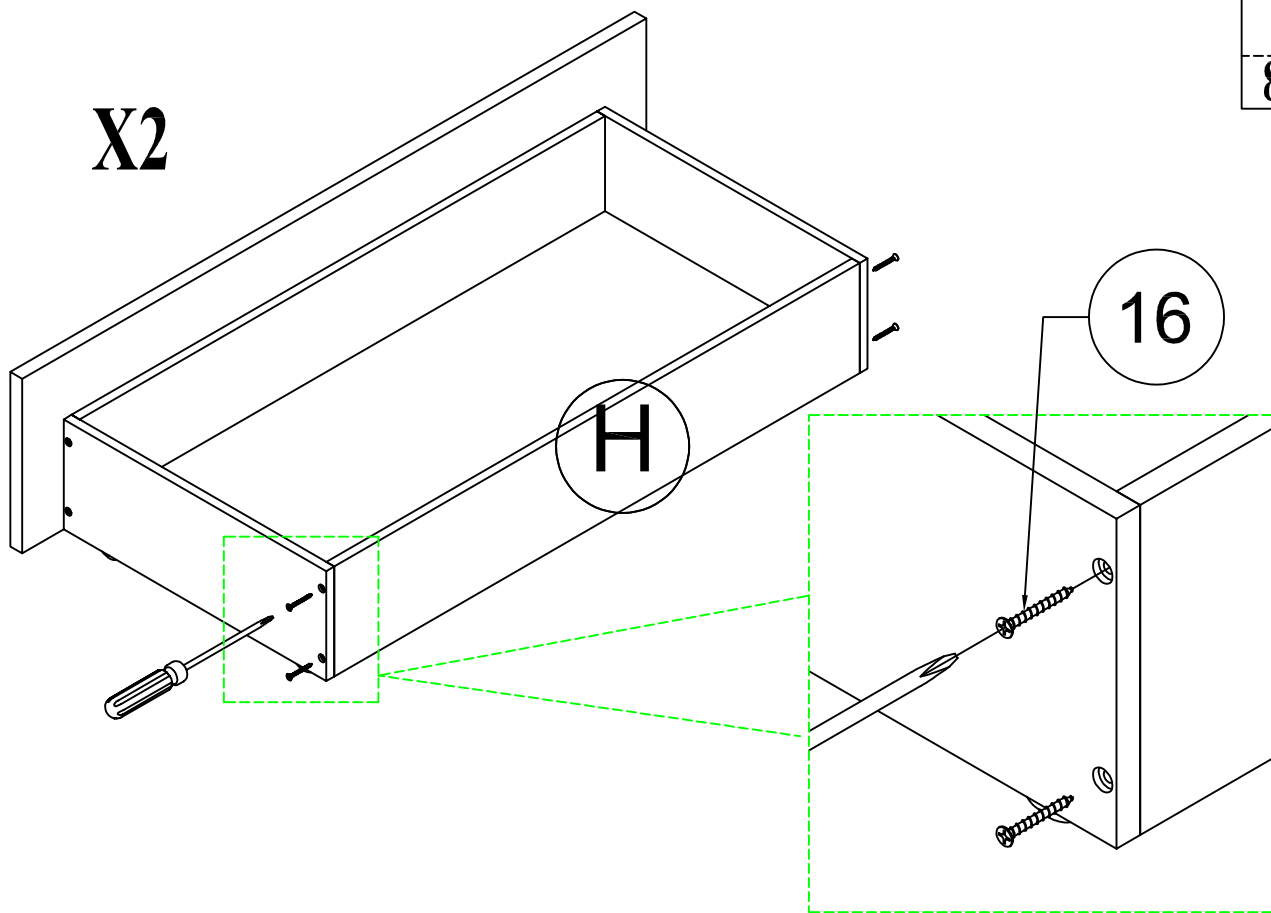

STEP 7-1: Following below illustration:

4



16pcs

17

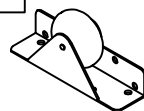

8pcs

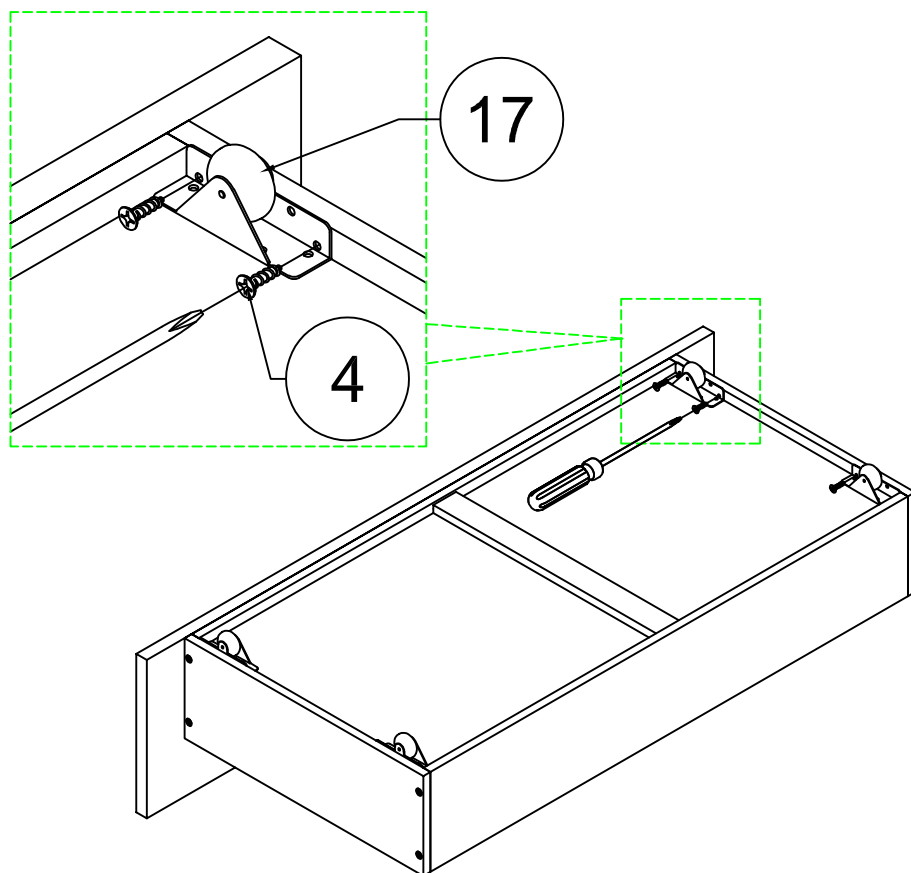

X2

FINISH

