

WF313500
WF313501

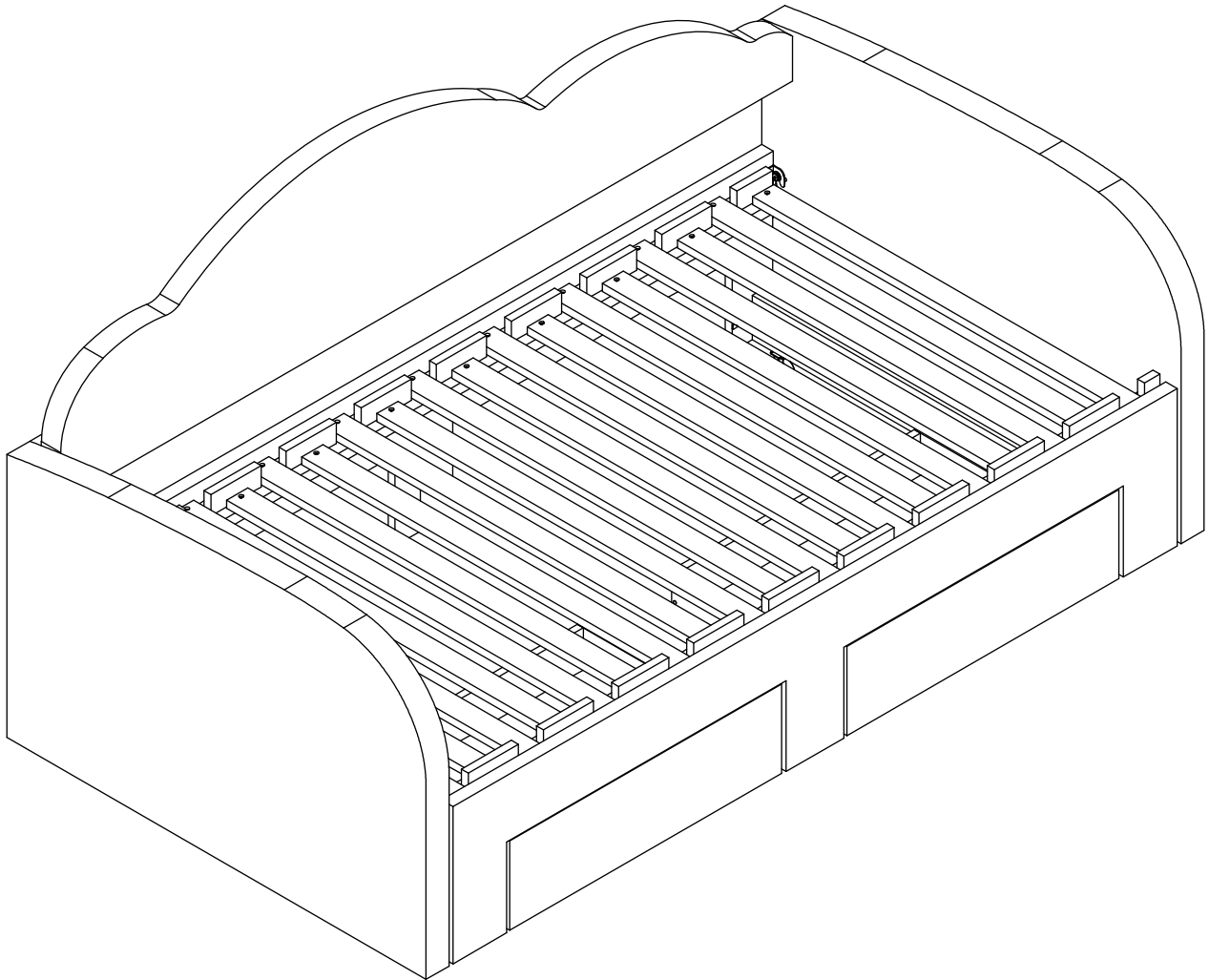

ASSEMBLY INSTRUCTIONS

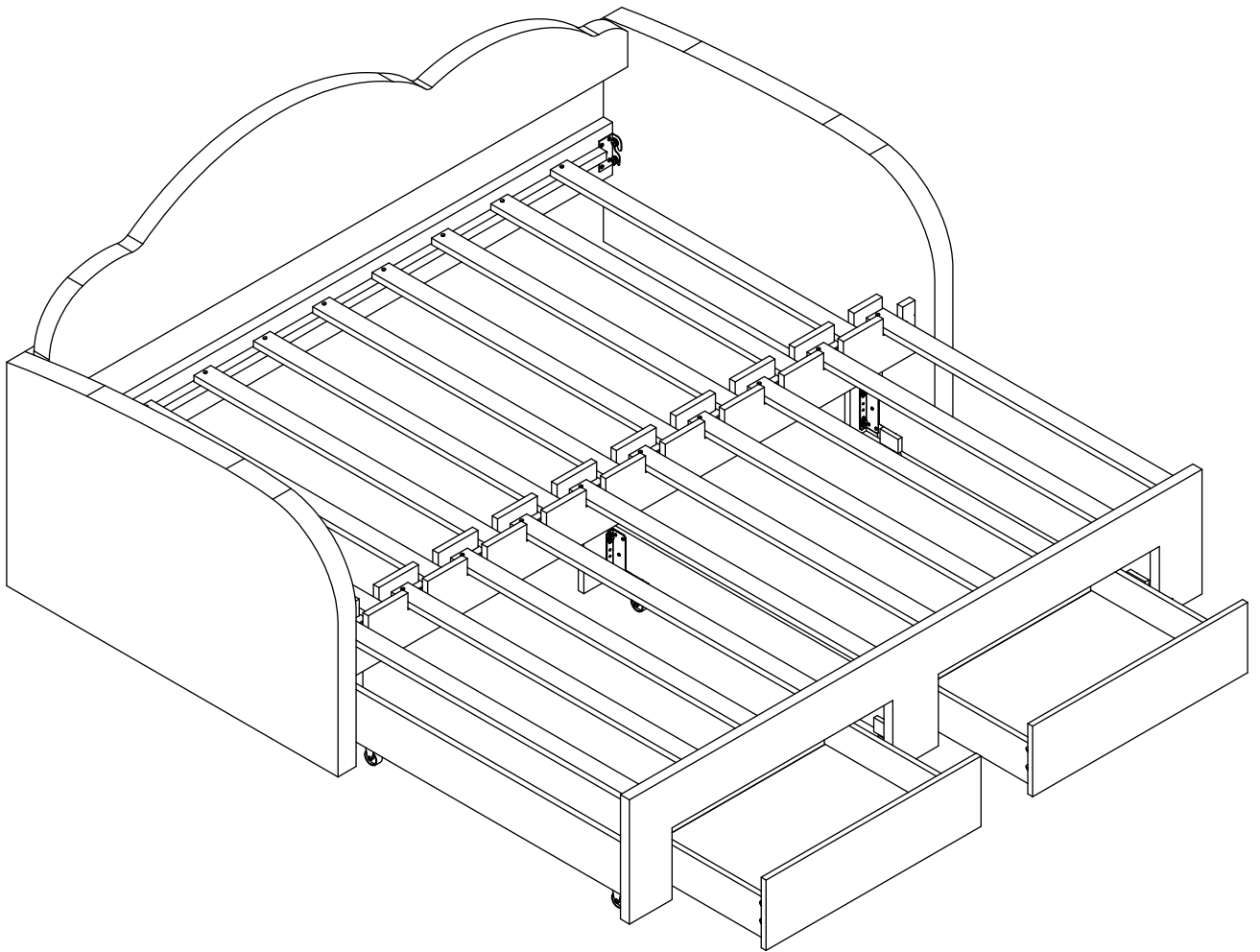

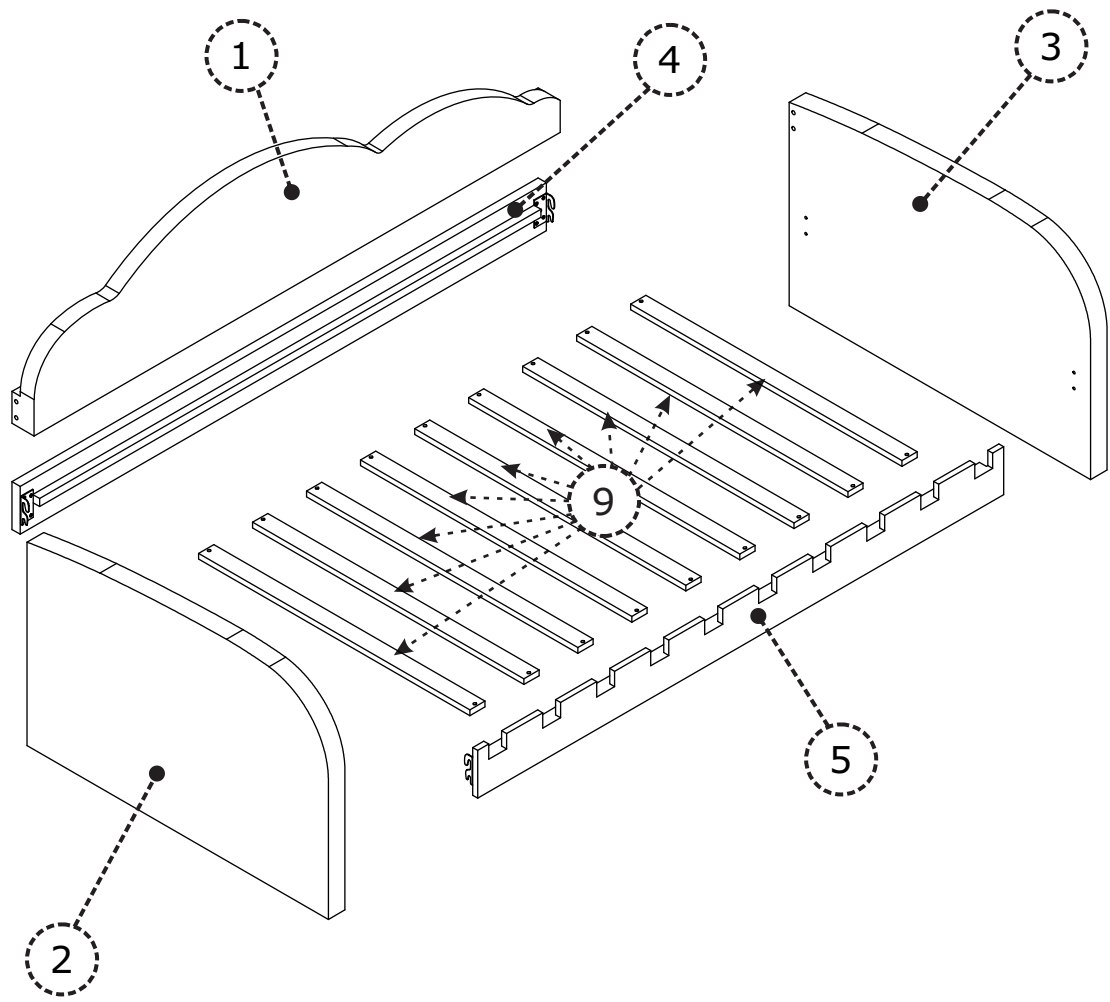

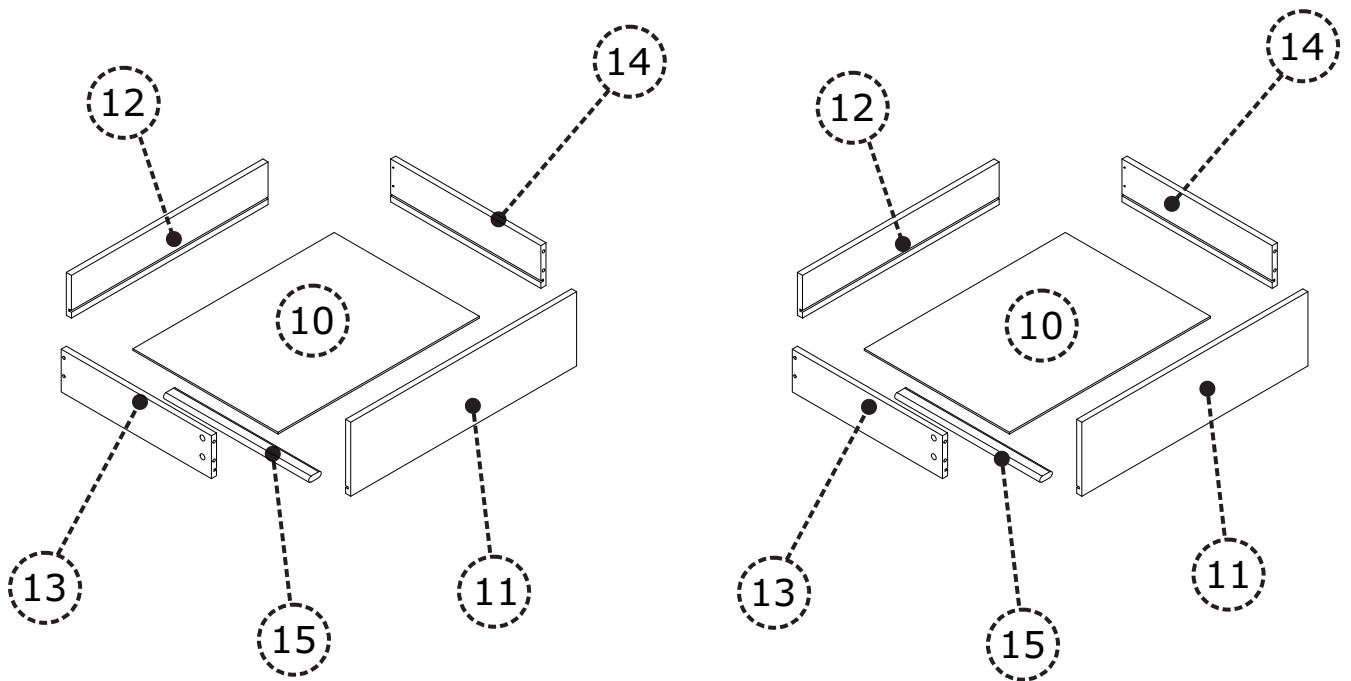
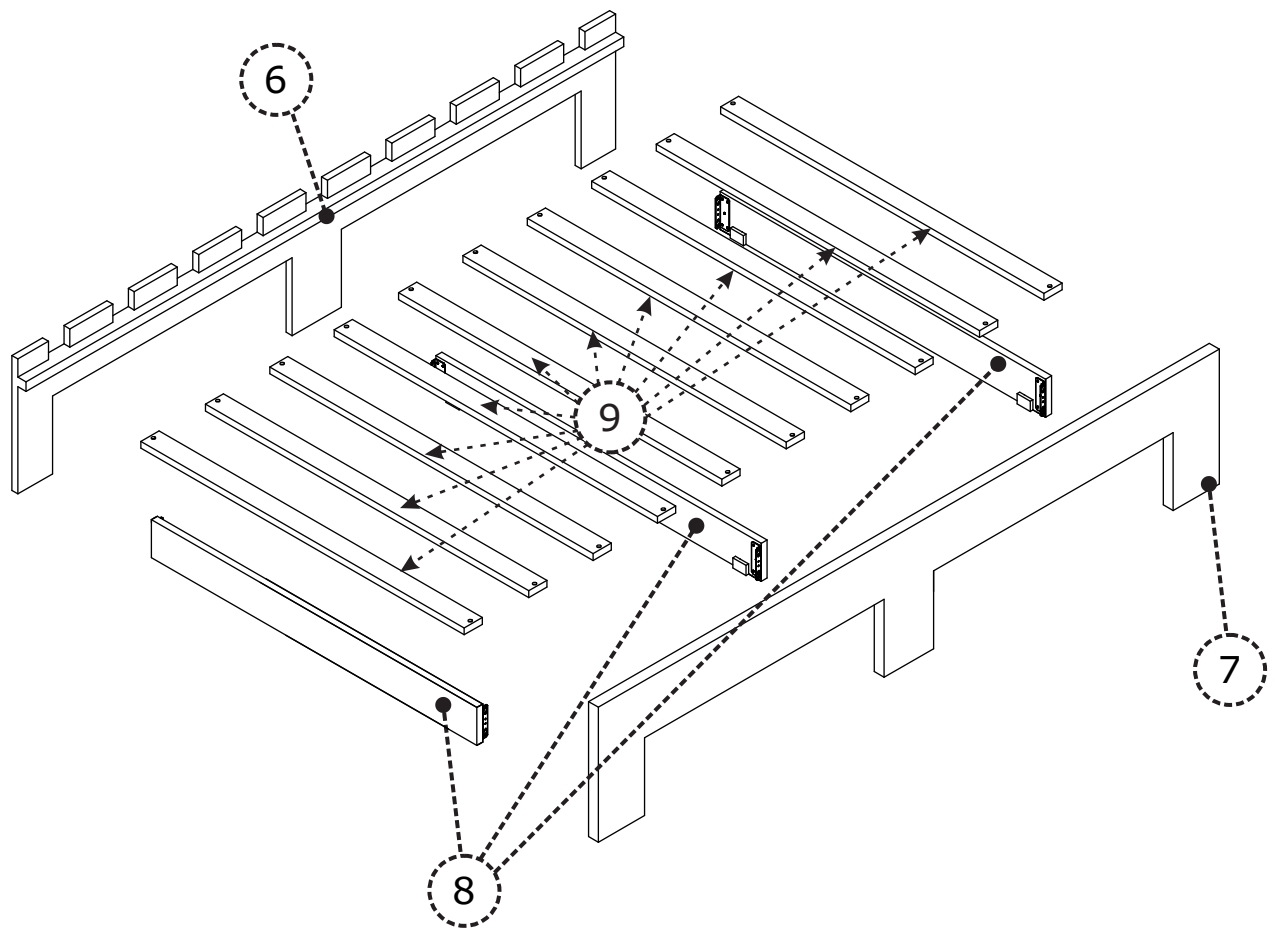

PARTS

Check that you've received
all parts listed below.

BOX: 1/2
WF313500

1 x 1

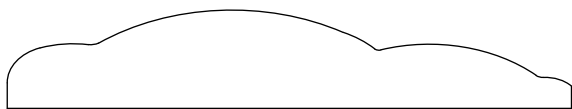

Head Board

4 x 1



Back Rails

5 x 1

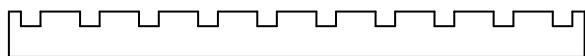

Front Rails

6 x 1

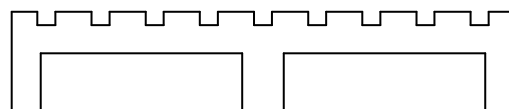

Back Rails (Trundle)

7 x 1

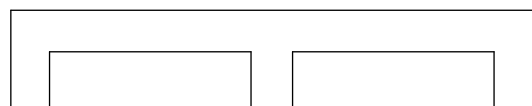

Front Rails (Trundle)

8 x 3



Lower Stretcher (Trundle)

11 x 2



Front Drawers

12 x 2



Back Drawer

13 x 2



Left Drawer

14 x 2

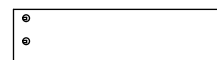

Right Drawer

PARTS

Check that you've received
all parts listed below.

BOX: 2/2
WF313501

2 x 1

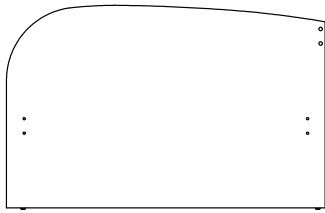

Side Board Left

3 x 1

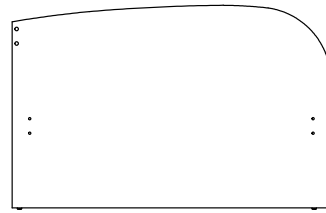

Side Board Right

9 x 19

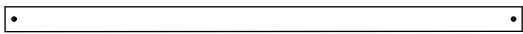

Slats

10 x 2



Bottom Drawer

15 x 2

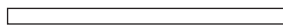

Support Drawer



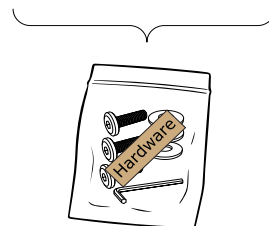













Hardware



HARDWARE

Check that you've received all hardware listed below.

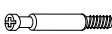
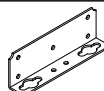
Hardware List

No.	OUTLOOK	DESC	QTY
(A)		Bolts 5/16"x15 mm	12
(B)		Bolts 5/16"x30 mm	8
(C)		Bolts 5/16"x60 mm	4
(D)		Plain washer Ø19x1.5 mm	24
(E)		Spring washer Ø13x1 mm	24
(F)		Allen key 80x30x4 mm	1
(G)		Screws Ø4x30 mm	38
(H)		Screws Ø4x25 mm	10
(I)		Screws Ø3x10 mm	44
(K)		Wheel 45x25x50 mm	6
(L)		Wheel 50x35x38 mm	8
(M)		Steel Pat 50x35x38 mm	2
(N)		Cam lock Ø15x13 mm	8
(O)		Cam lock Ø10x11 mm	8
(P)		Cam lock Ø6x35 mm	8
(Q)		Steel Pat 126x42x27 mm	6
(T)		Screws Ø4x15 mm	30

STEP 1

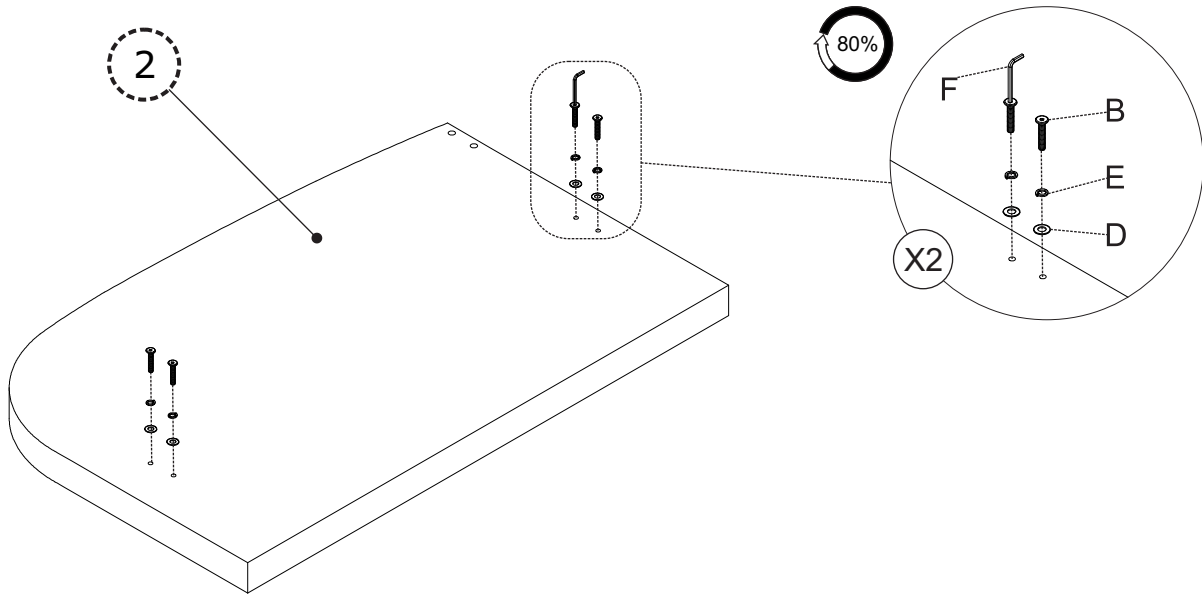
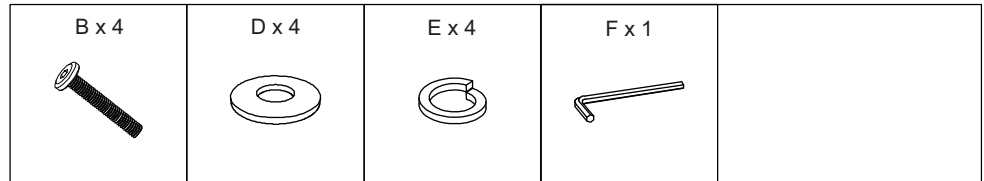

STEP 2

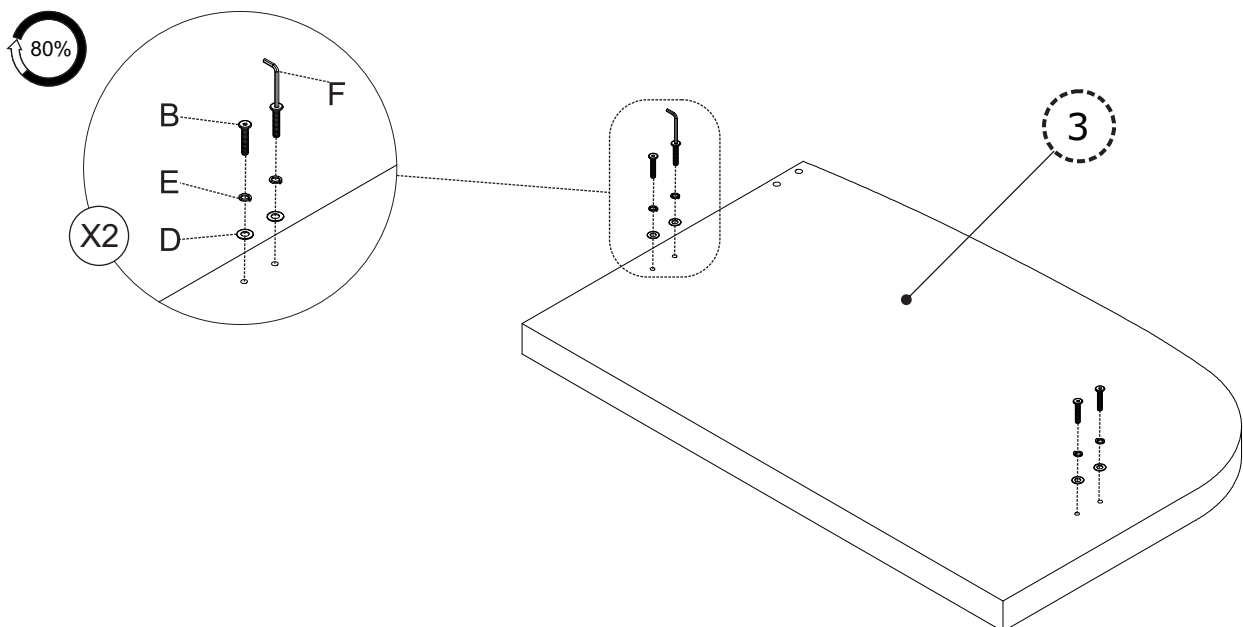
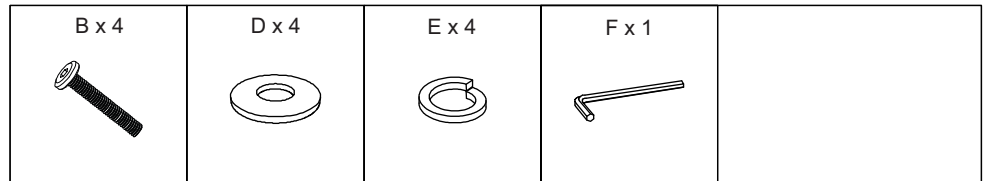

STEP 3

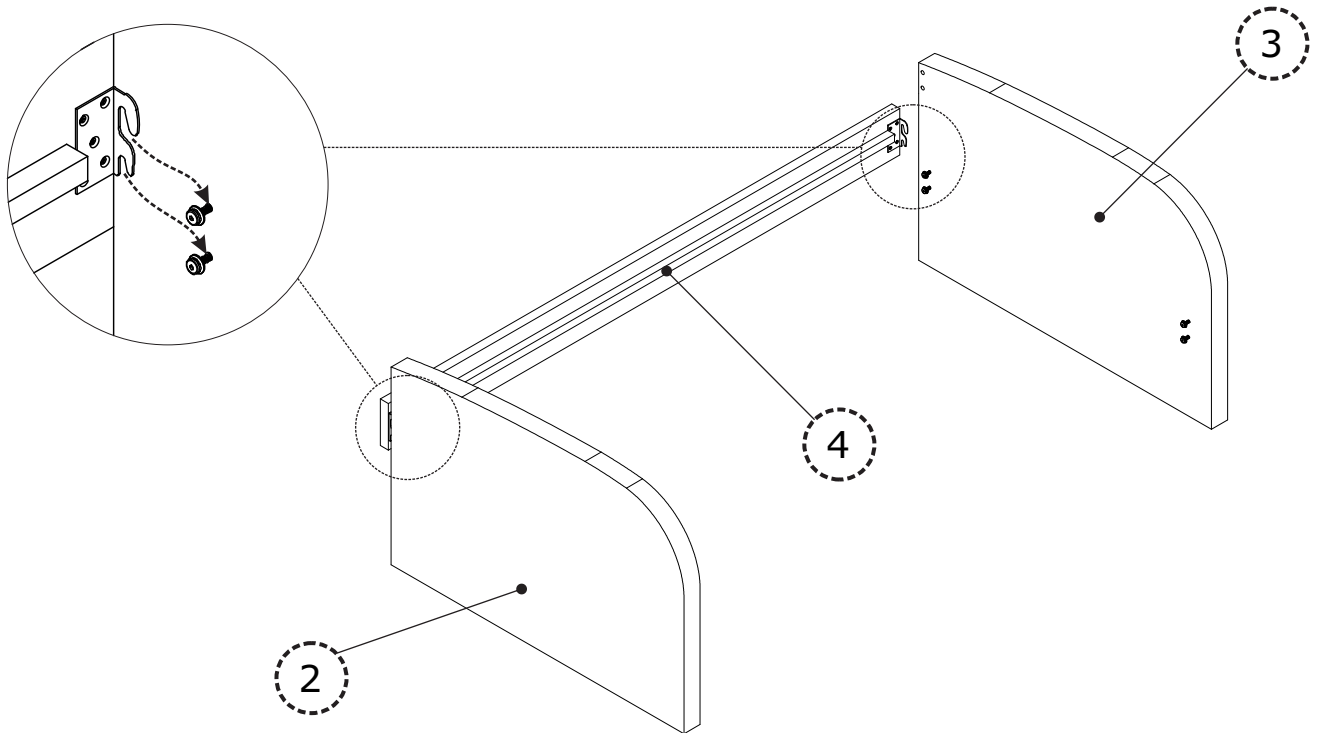
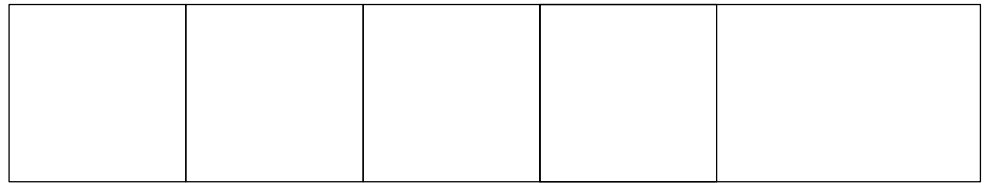

STEP 4

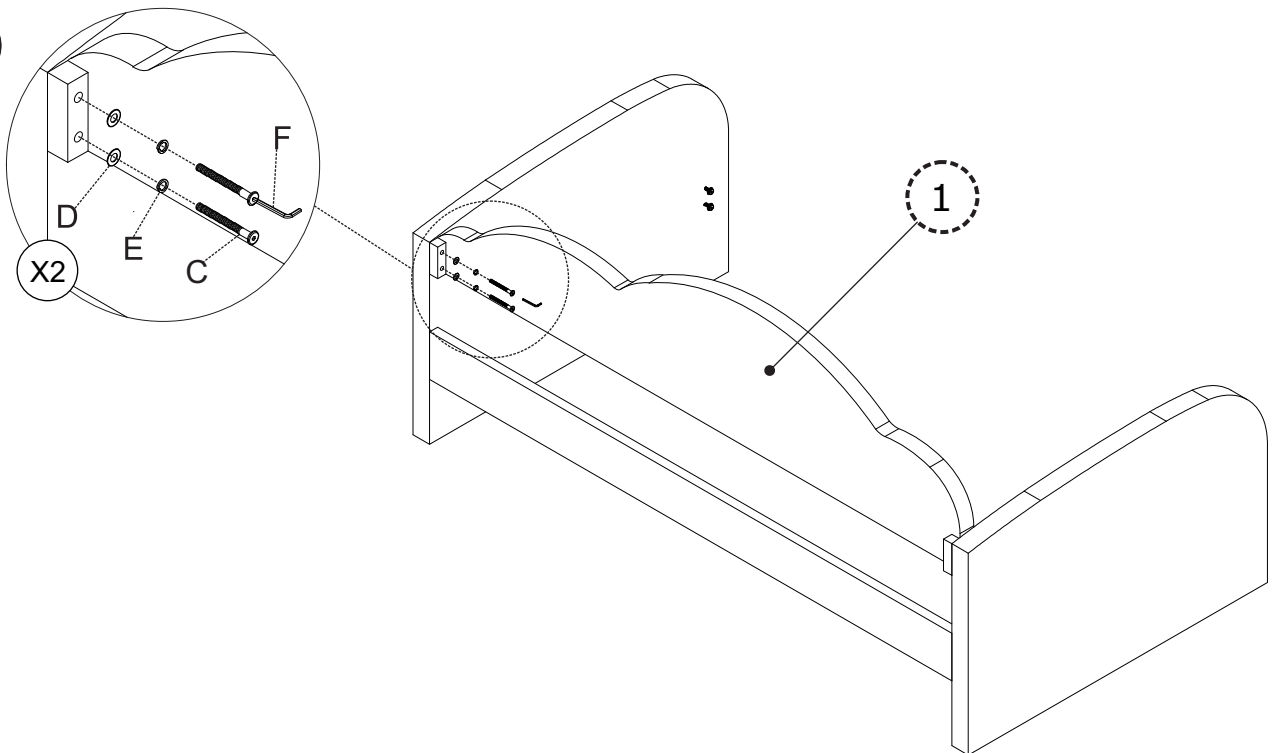
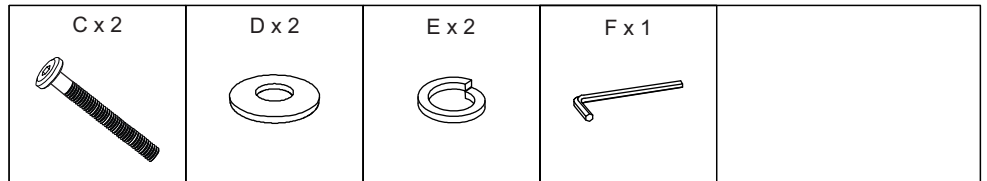



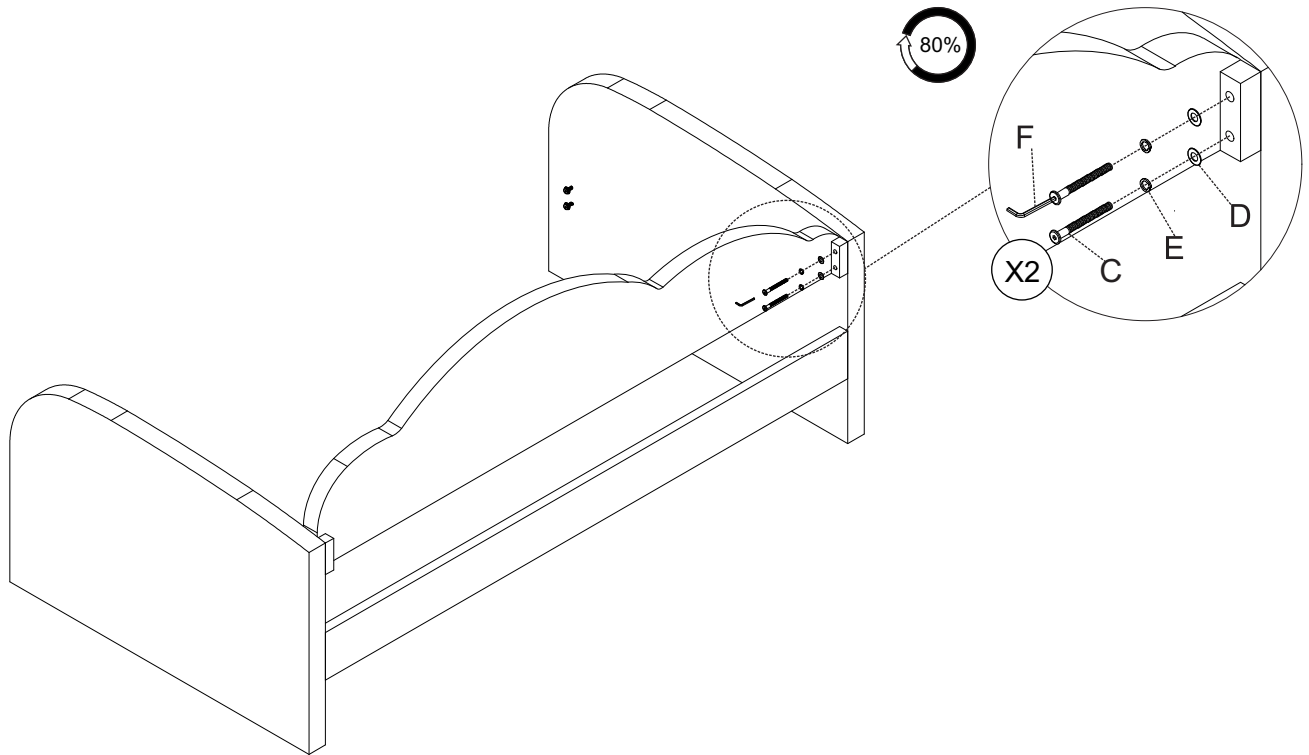
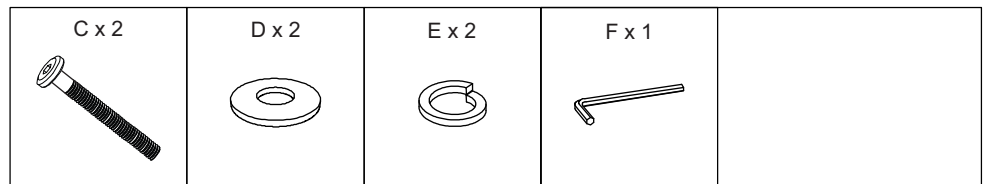

STEP 5

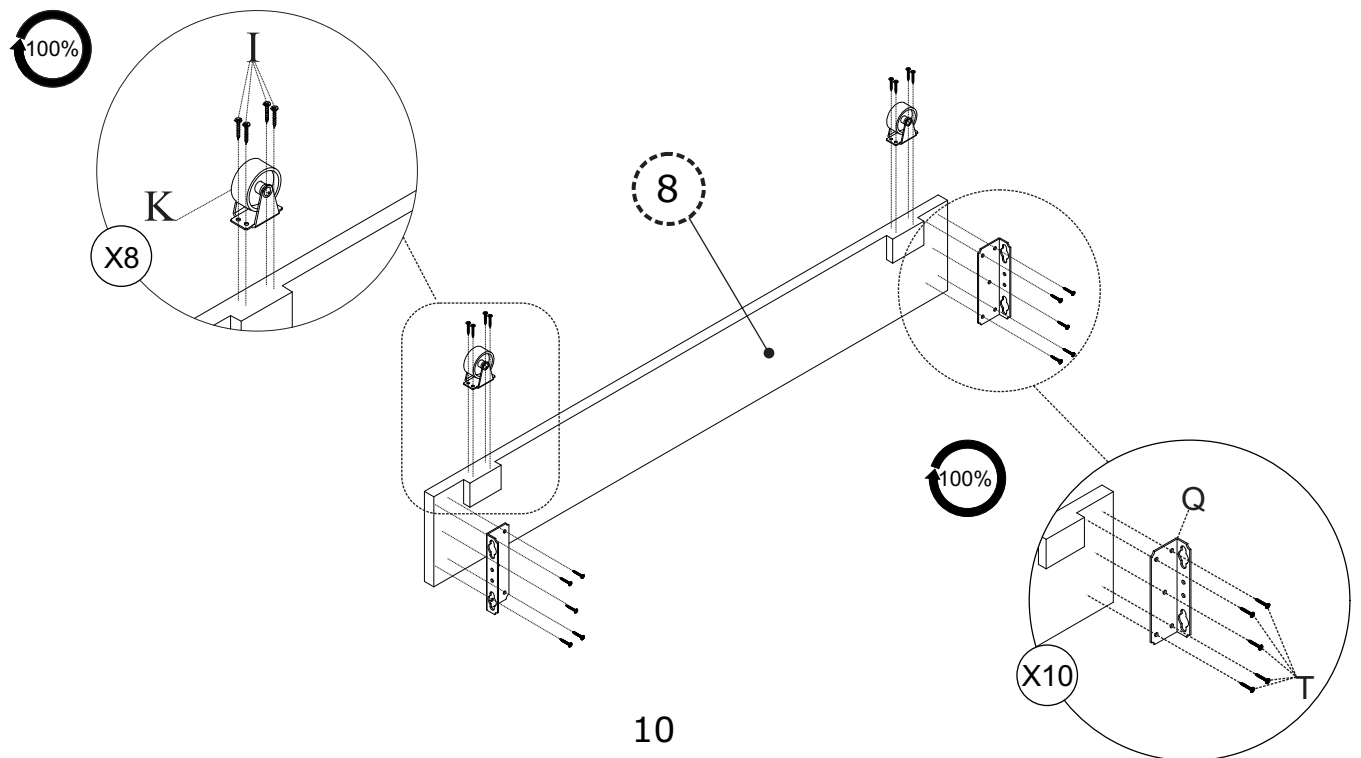
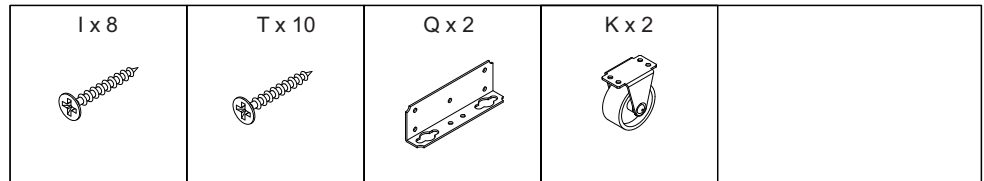

STEP 6





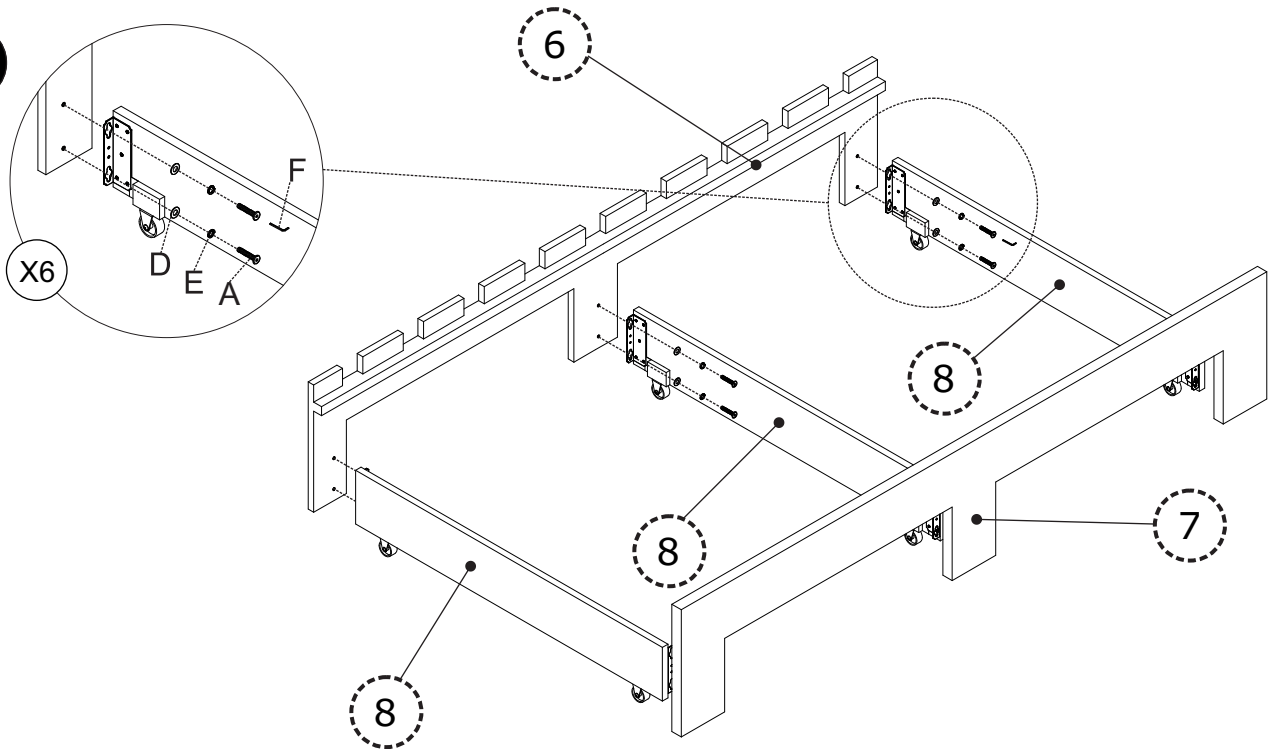

STEP 7

A x 6 	D x 6 	E x 6 	F x 1 	
--	--	--	--	--

100%



STEP 8

A x 6 	D x 6 	E x 6 	F x 1 	
--	--	--	--	--

100%

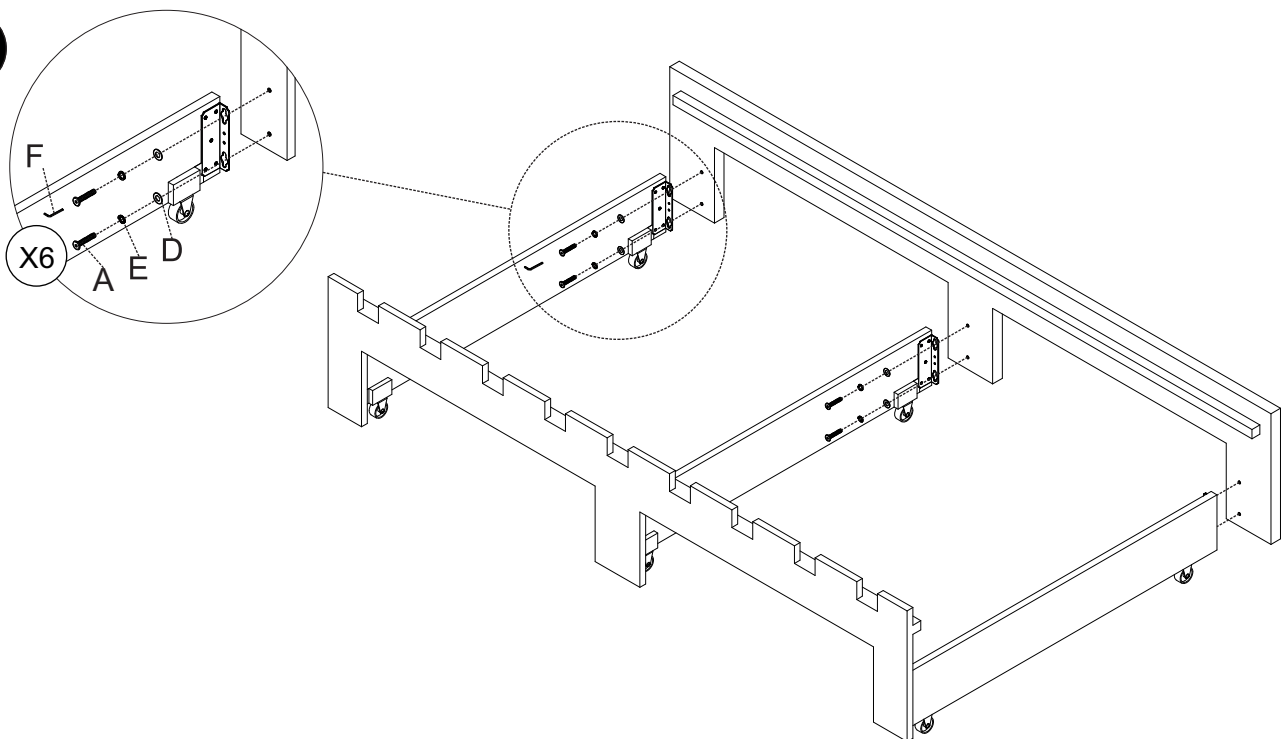

STEP 9

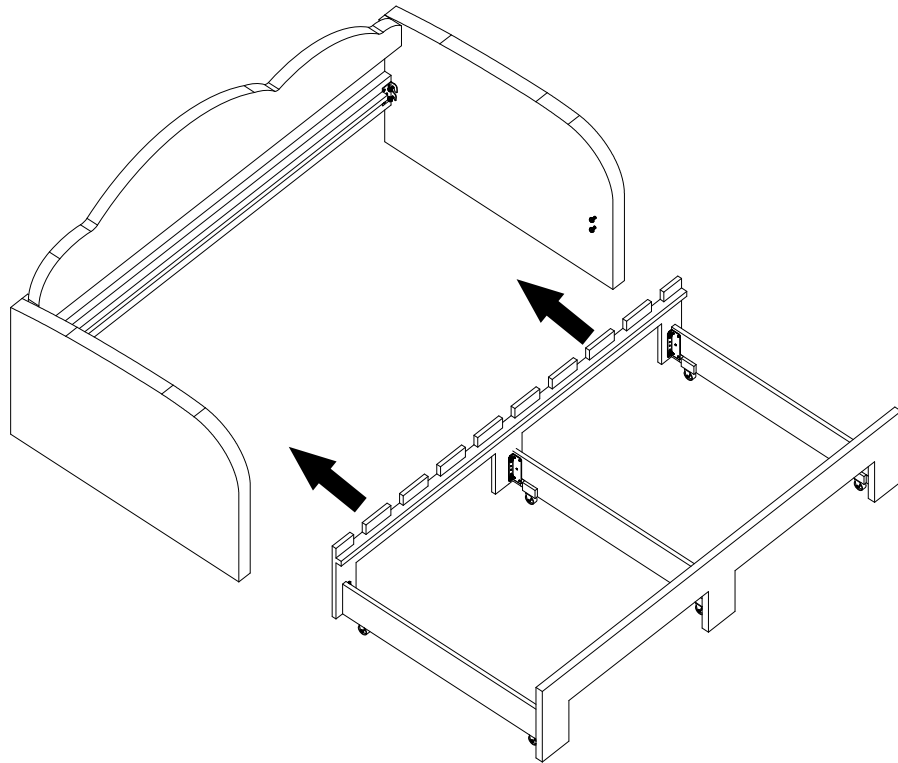
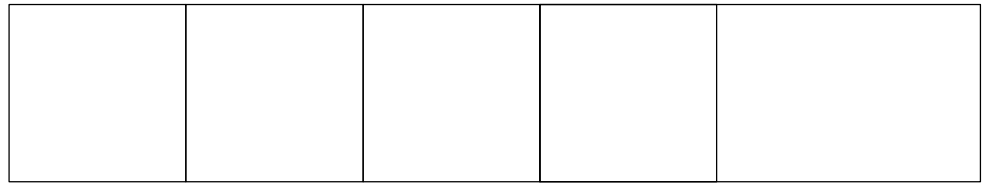

STEP 10

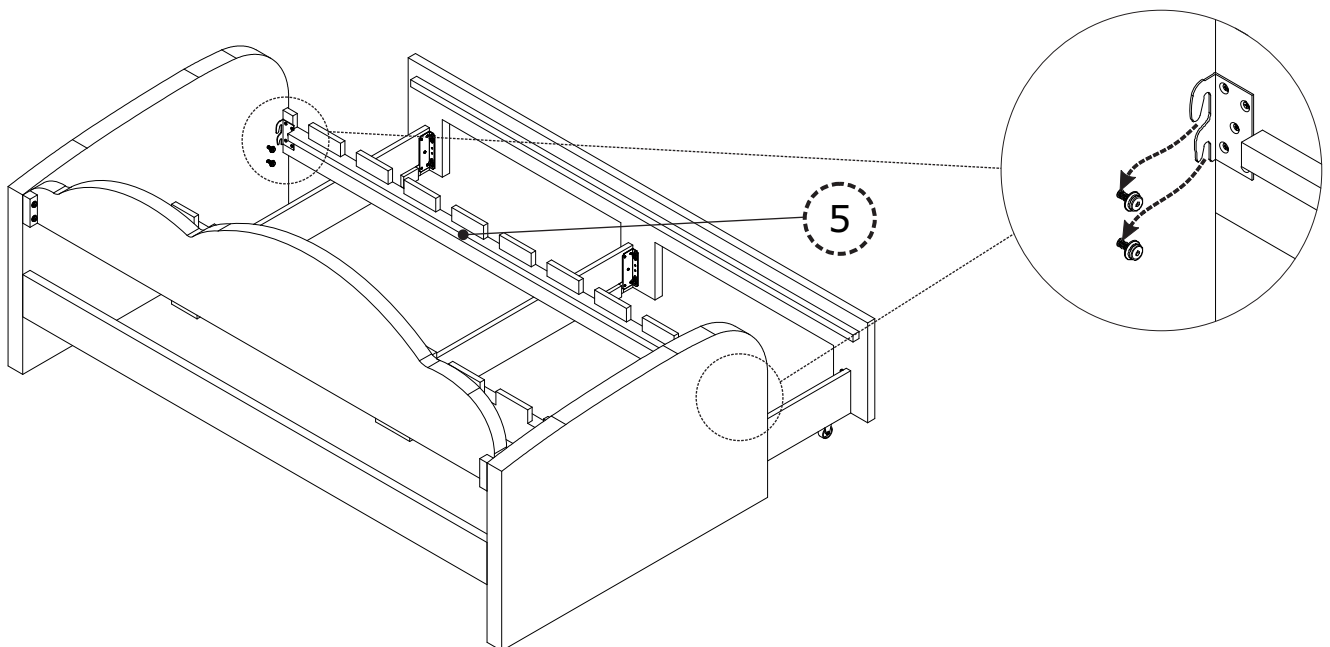
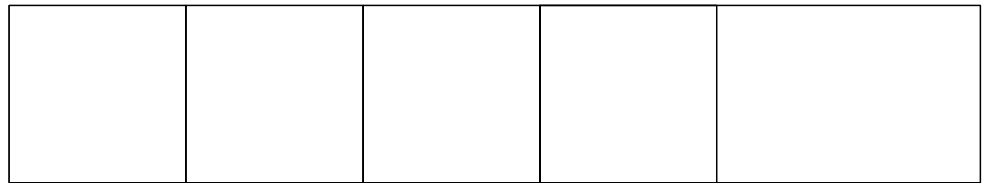

STEP 11

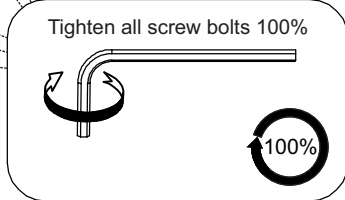
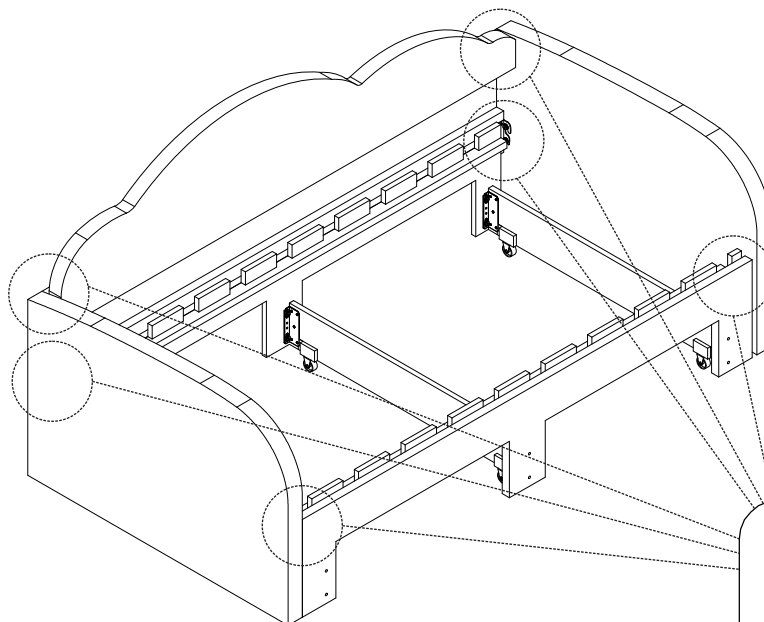
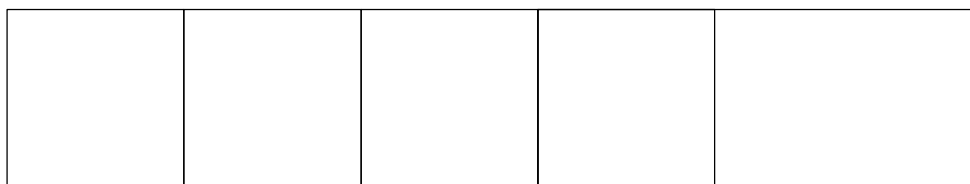

STEP 12

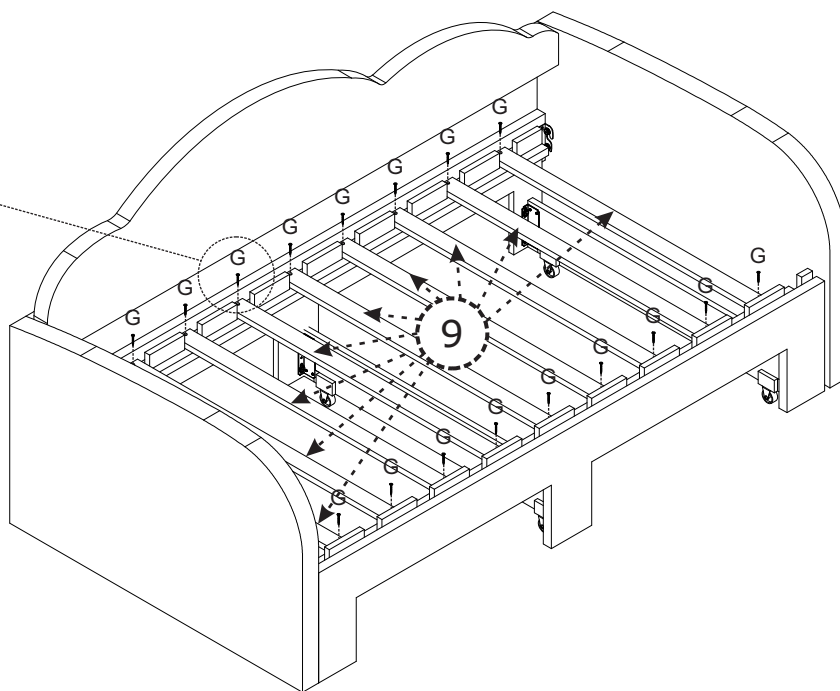
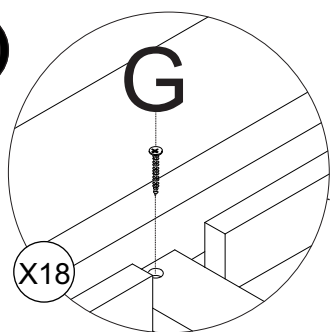
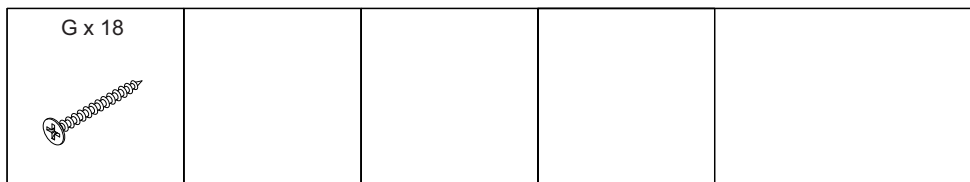

STEP 13

G x 20

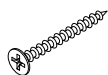

100%

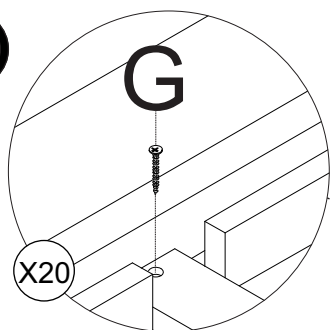

X20

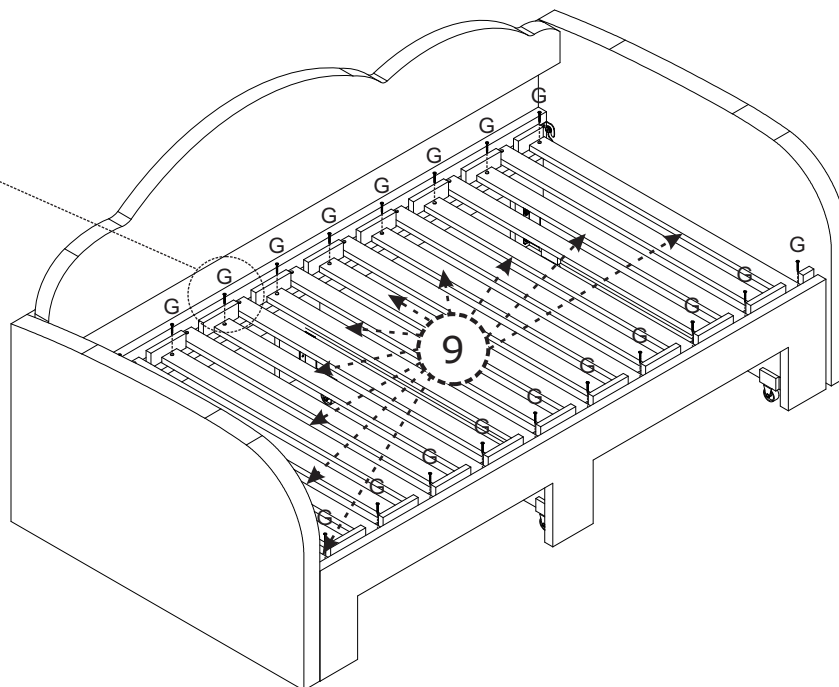

STEP 14

O x 4

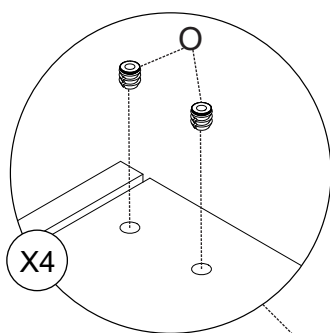

X4

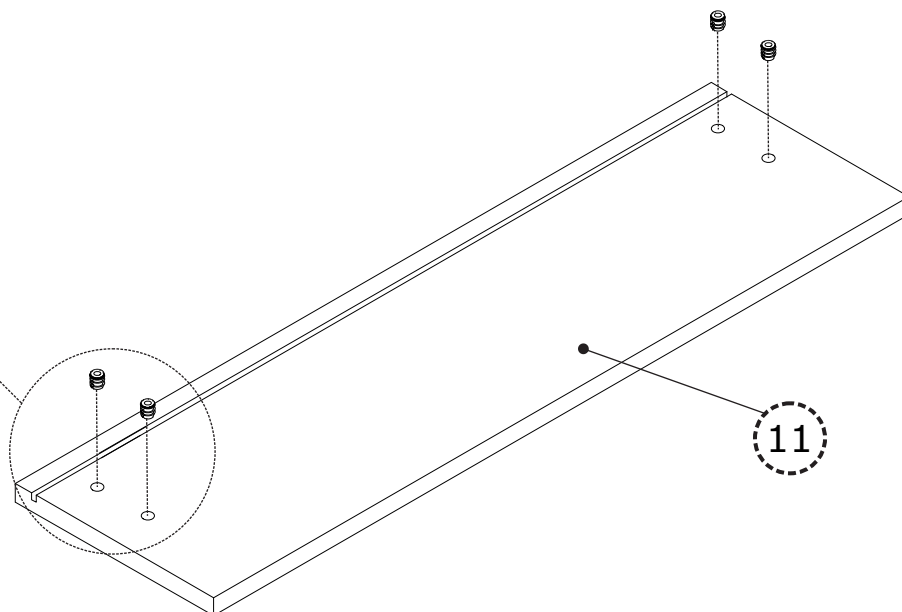

11

STEP 15

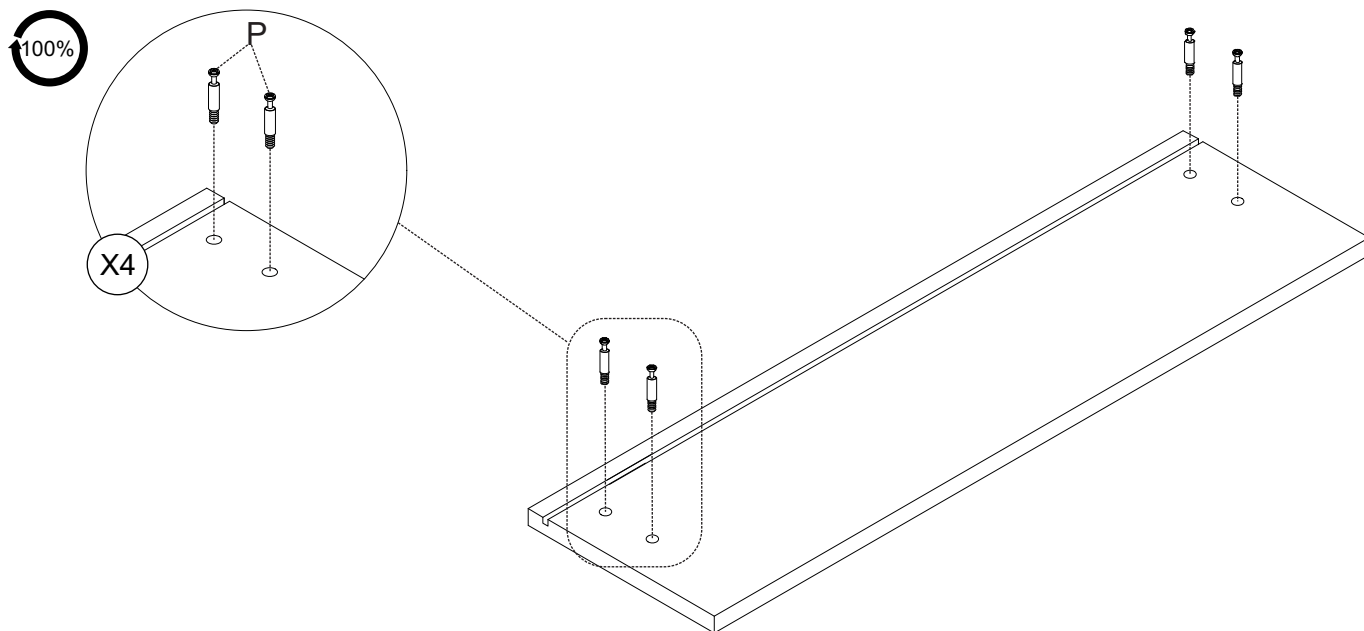
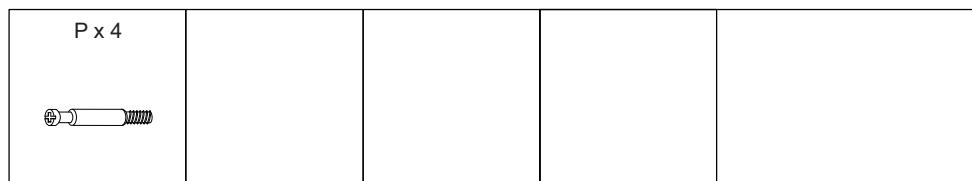

STEP 16

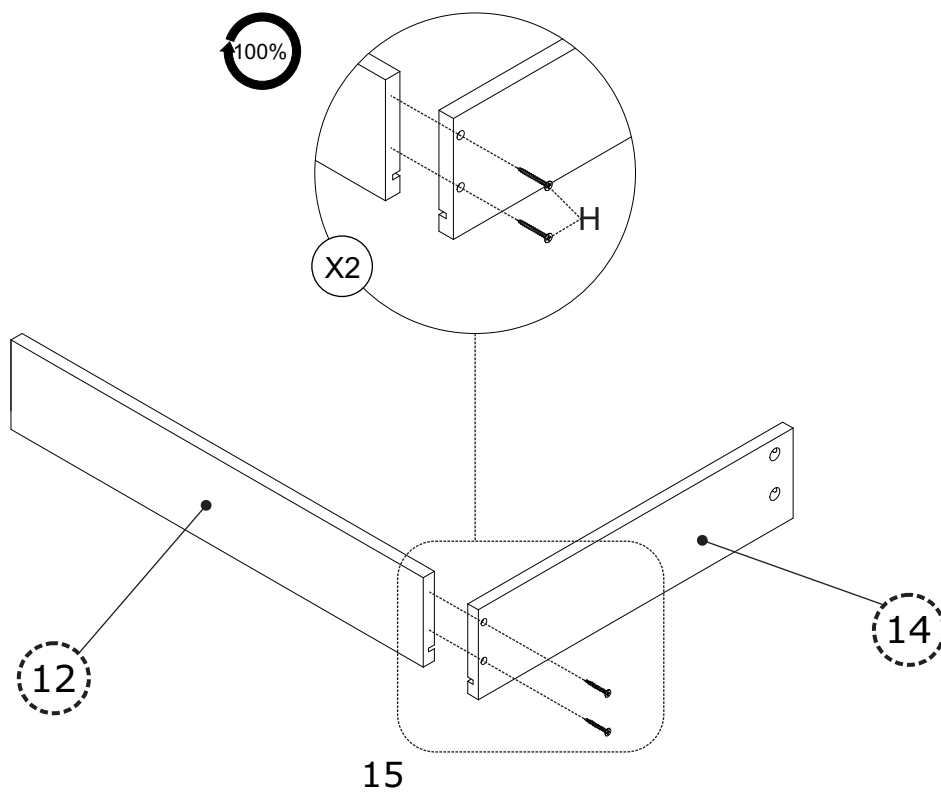
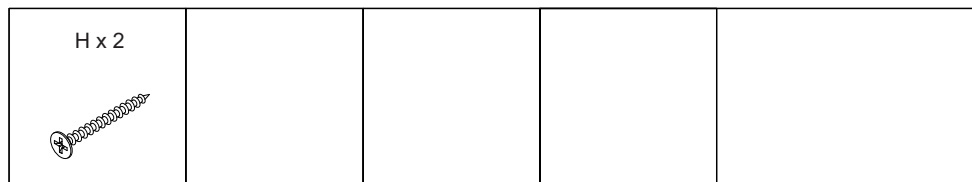

STEP 17

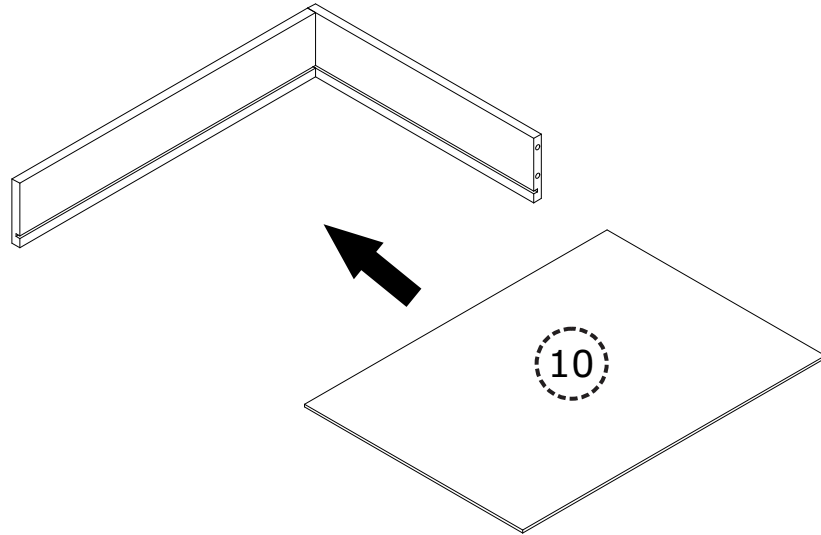
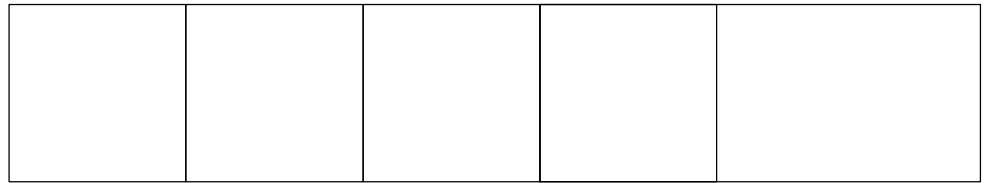

STEP 18

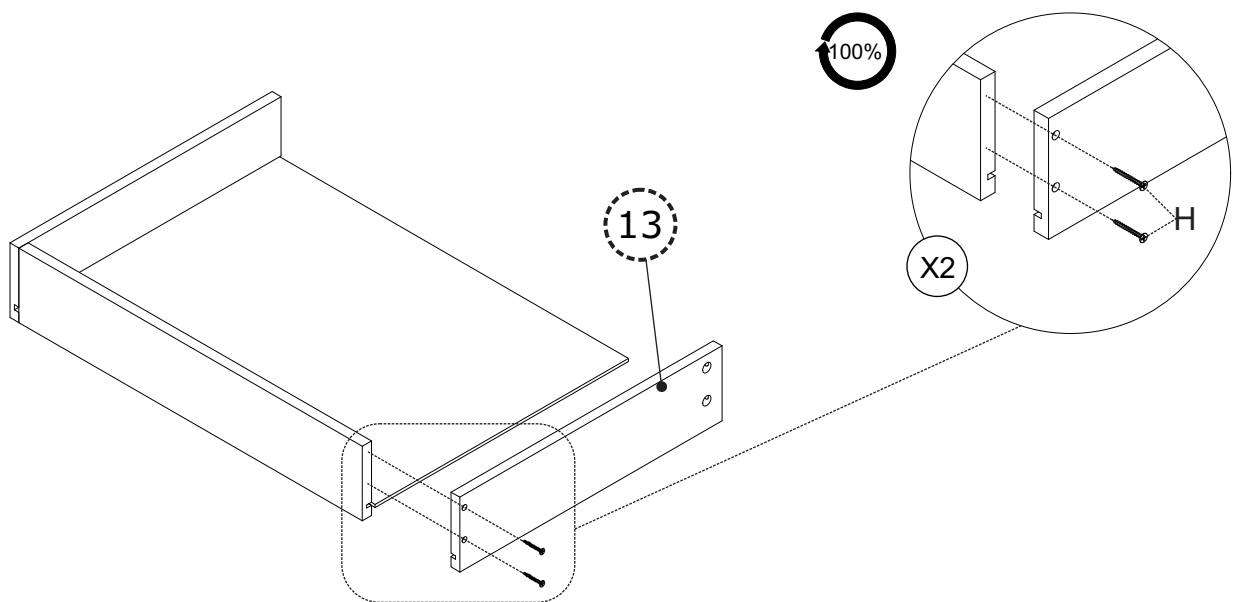
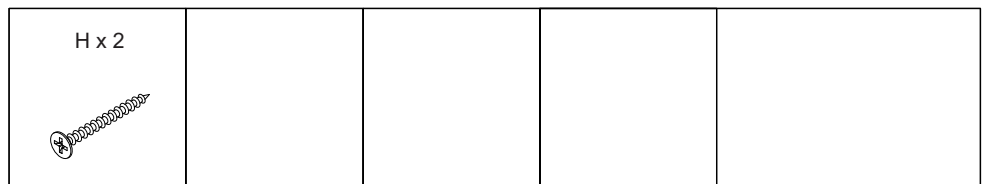

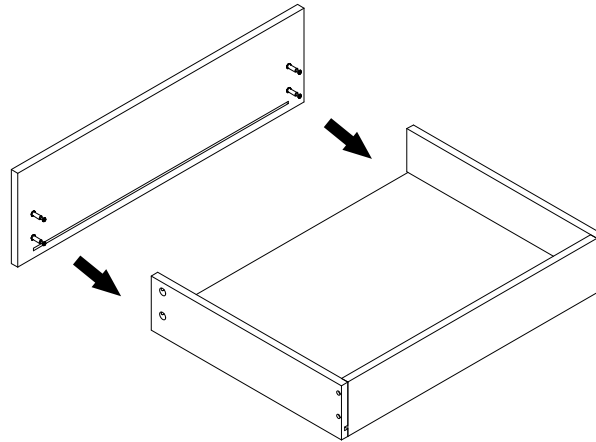
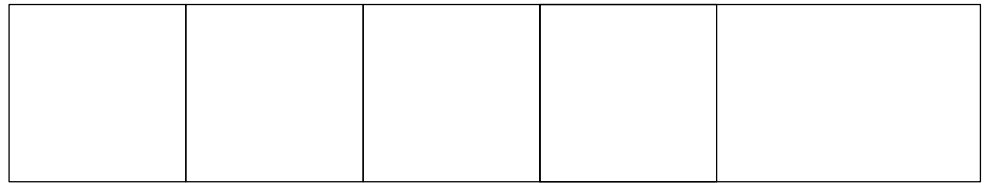

STEP 19

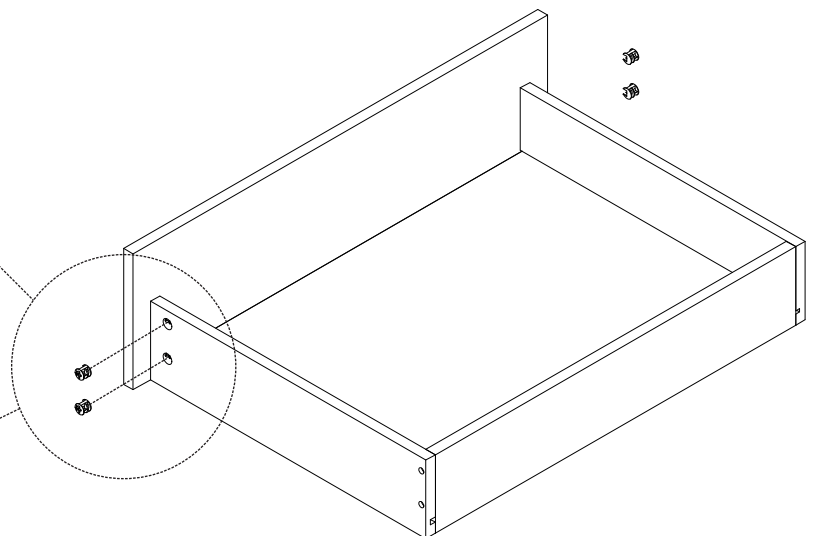
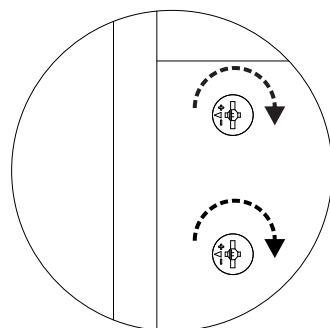
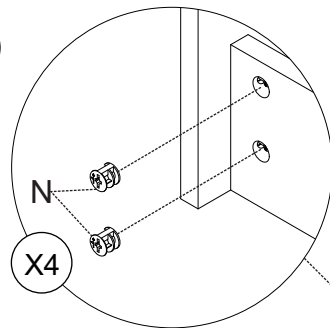
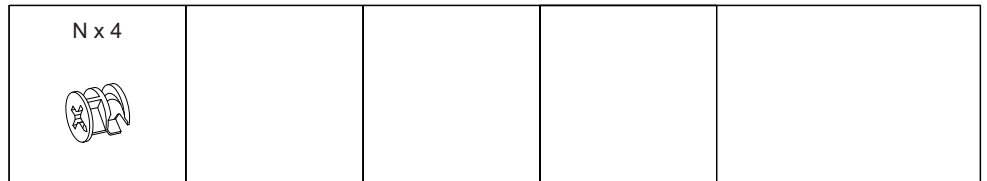

STEP 20

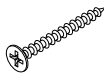

STEP 19

H x 1	I x 2	M x 1		
				

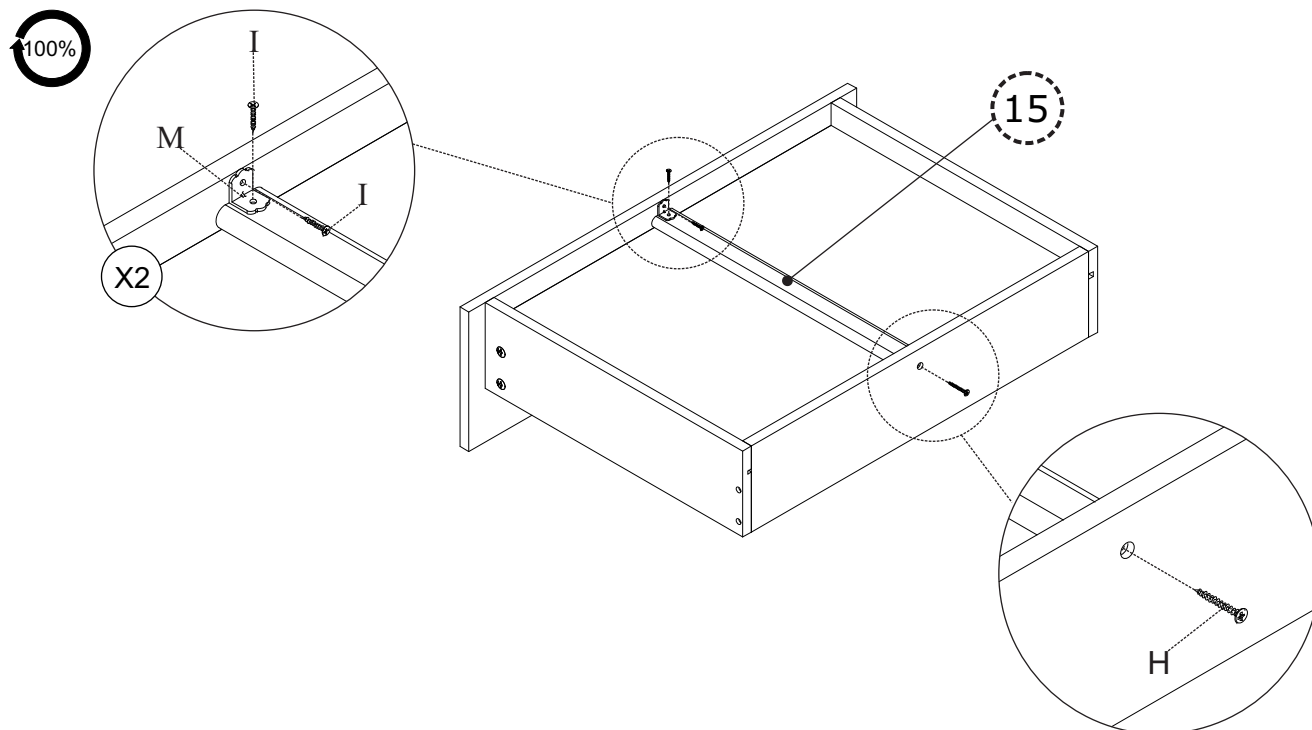

STEP 20

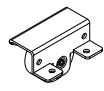
I x 8	L x 8			
				

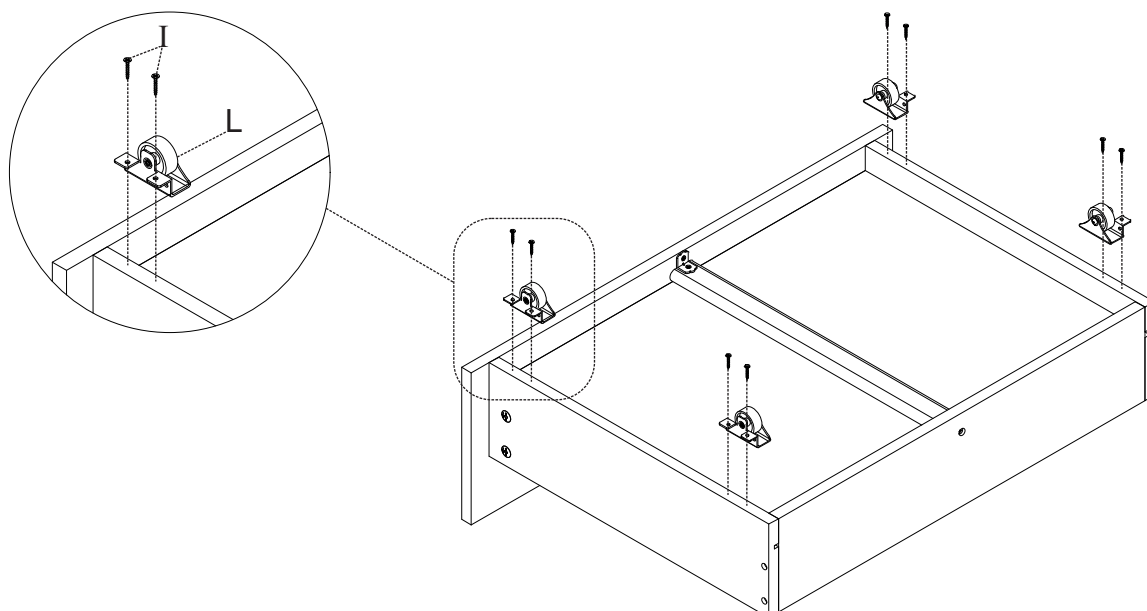

STEP 21

