

ASSEMBLY INSTRUCTION

SKU CODE : WF311381 / WF311382

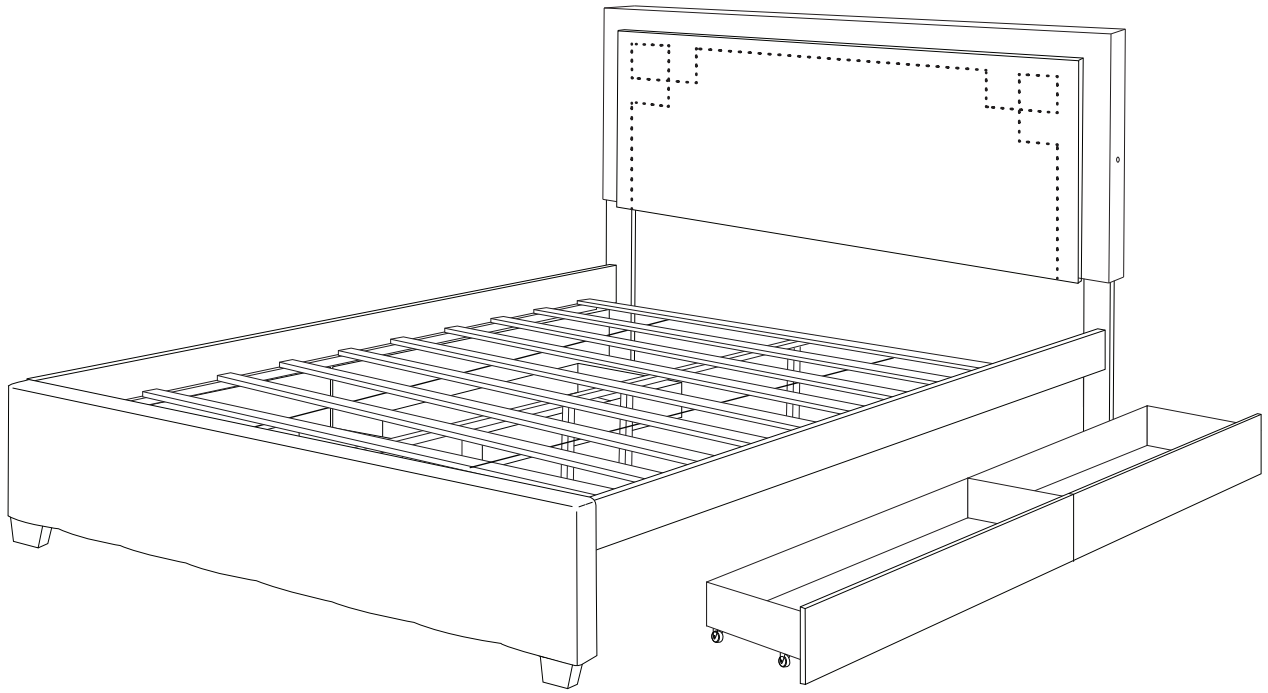

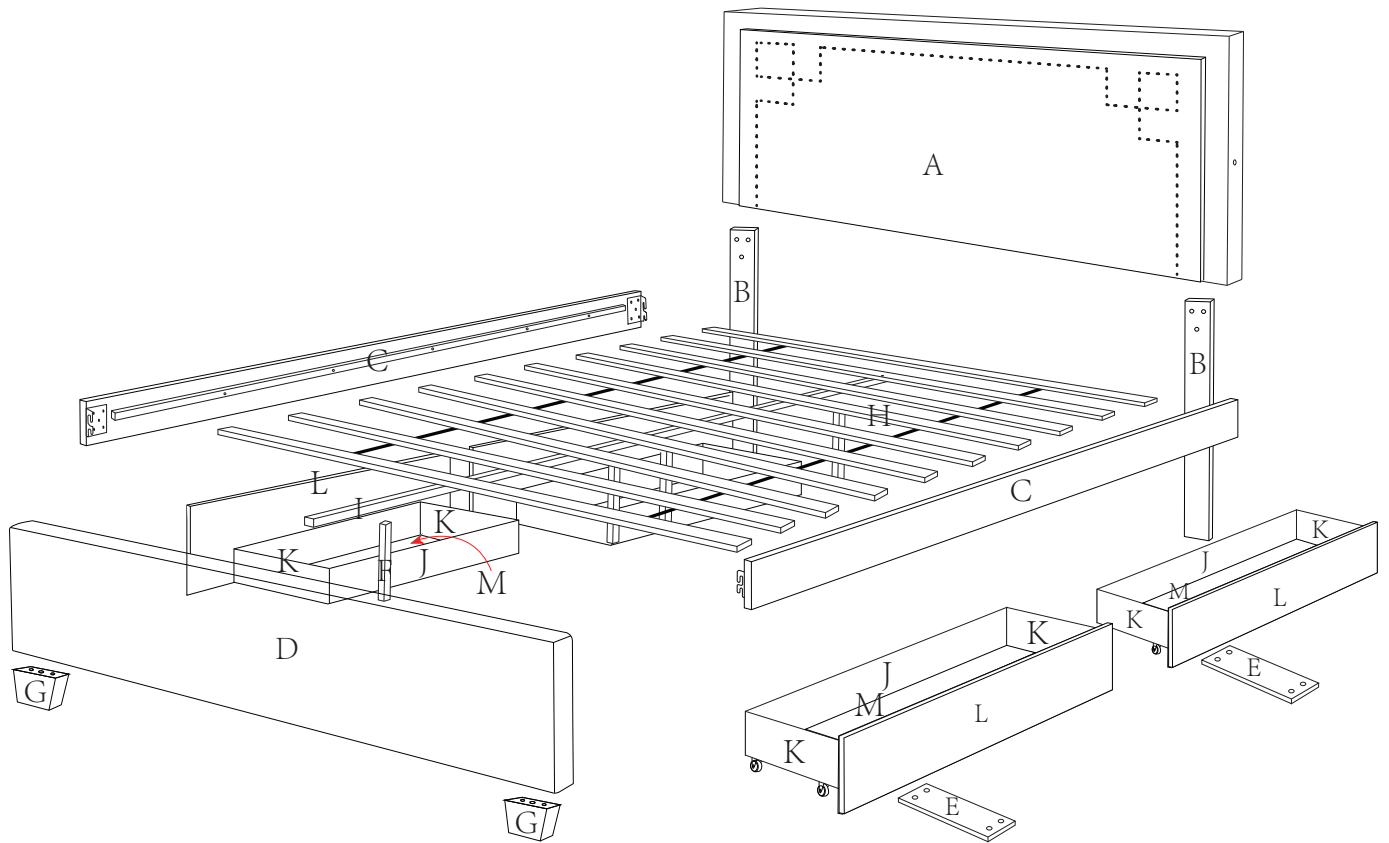



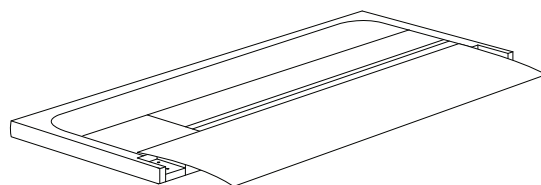

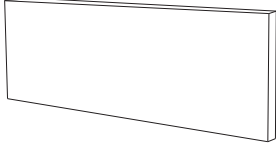
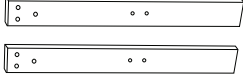
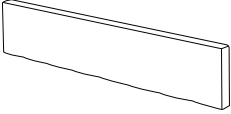
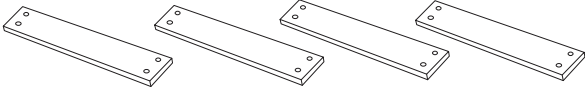
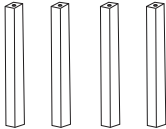
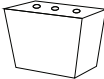
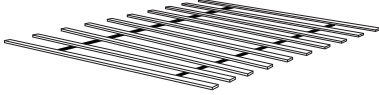
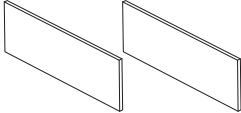
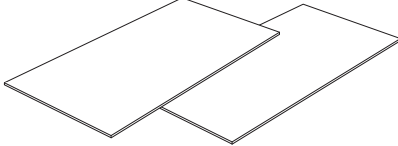

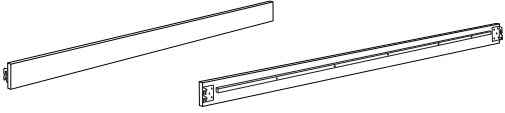
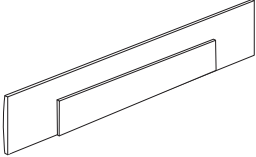
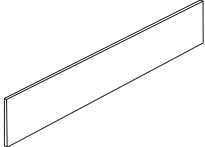
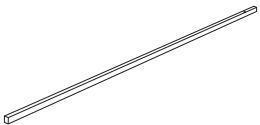

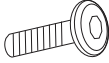

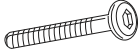

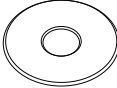

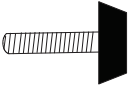
Bed Parts are shipped inside a compartment
in the back of the headboard.

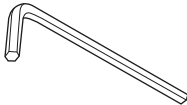

NO	PARTLIST (BOX 1 OF 2) WF311381	QTY
A	Headboard 	1 pc
B	Headboard Leg 	2 pcs
D	Footboard 	1 pcs
E	Drawer Support 	4 pcs
F	Center Support Leg 	4 pcs
G	Bed Leg 	2 pcs
H	Bed Slat Queen 	10 pcs
K	Drawer Side Panel 	8 pcs
M	Drawer Bottom Panel 	4 pcs

	PART LIST (BOX 2 OF 2) WF311382	
C	Side Rail 	2 pcs
L	Drawer Front Panel 	4 pcs
J	Drawer Back Panel 	4 pcs
I	Center Support Rail 	1 pc

NO	HARDWARE LIST (BOX 1 OF 2) WF311381	QTY
1	JCBB M8 x 20mm 	8 pcs
2	JCBC M6 x 70mm 	2 pcs
3	JCBC M6 x 60mm 	4 pcs
4	JCBC M6 x 45mm 	6 pcs
5	Adapter 	1 pcs
6	Flat Washer M6 	6 pcs
7	Dowel M8 	4 pcs
8	Adjuster M6 	4 pcs
9	CSK M4 x 16mm 	8 pcs
10	CSK M4 X 25MM 	16 pc
11	CSK M3.5 x 16mm 	48 pcs
12	CSK M4 x 30mm 	20 pcs
13	Allen Key M4(100mm) 	1 pc

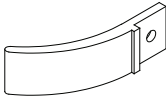
NO	HARDWARE LIST (BOX 1 OF 2)	QTY
14	Allen Key M5 	1 pc
15	CSK M4 x 38mm 	32 pcs
16	Wheel 	16 pcs
17	Stopper 	8 pcs

Read this instruction carefully. Remove all wrapping material, staples and straps from the carton. See hardware and furniture part list for guidance. Be sure you have all wooden furniture parts on a clean and flat surface, such as carpet or rug, to prevent from being scratched.



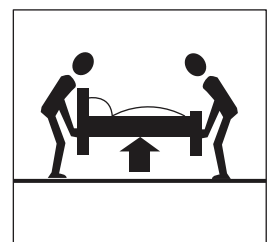

CAUTION :

1. Do not Full Tighten the nut or screw until all ready to assemble.
2. Do not Over Tighten the nut or screw to avoid causing damages to the thread.
3. Keep all hardware part out reach of children.



STEP 1

Drawer x 4 pcs

11	15	16	10
			
48 pcs	32 pcs	16 pcs	16 pcs

Step 1

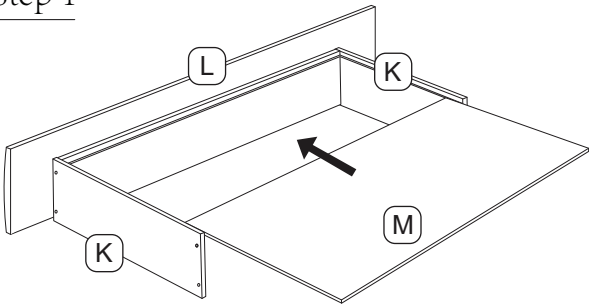

Step 2

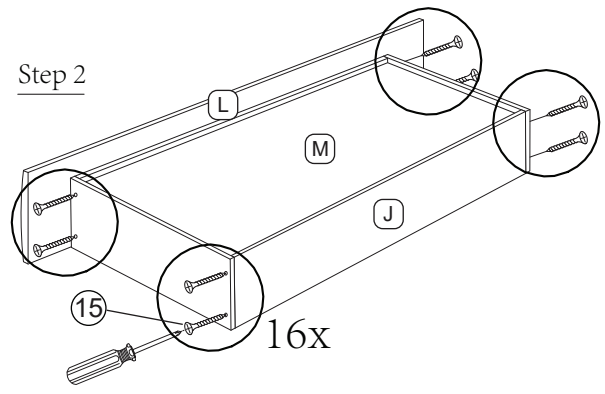

Step 3

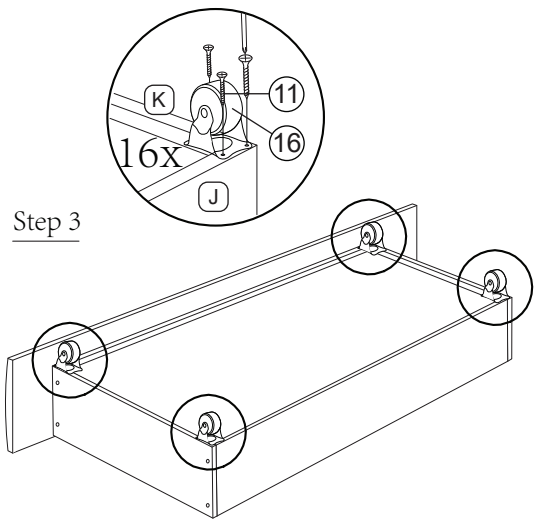

Step 4

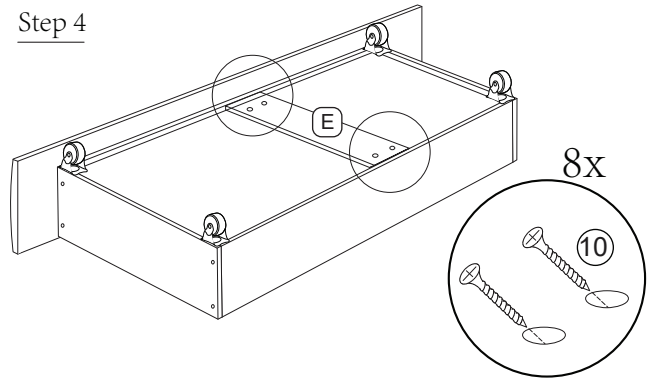

ASSEMBLY

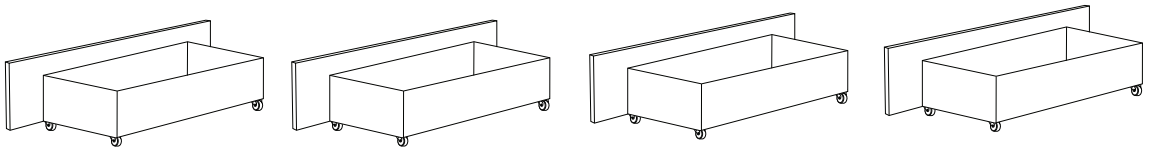

STEP 2

2	4	6	7
2 pcs	6 pcs	6 pcs	4 pcs

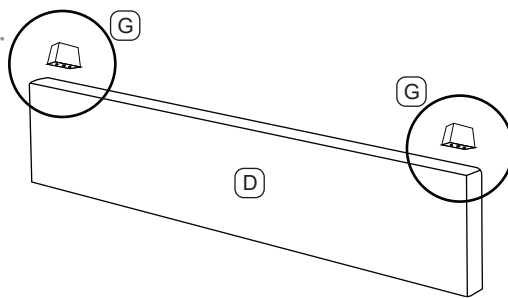
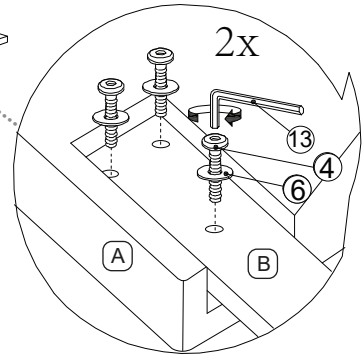
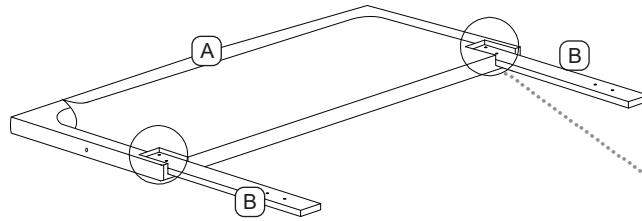
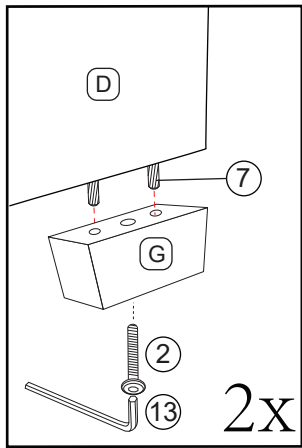

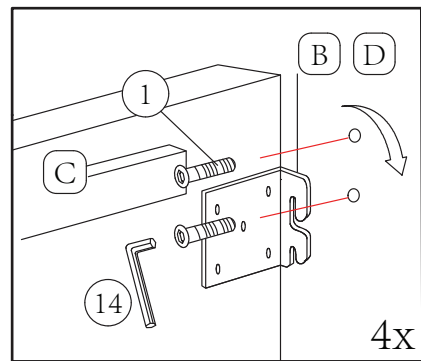
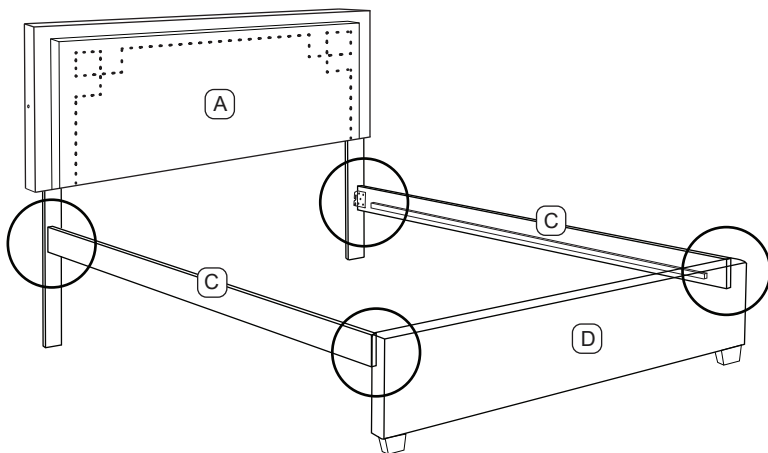

STEP 3

1
8 pcs

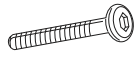

STEP 4

3	8
	
4 pcs	4 pcs

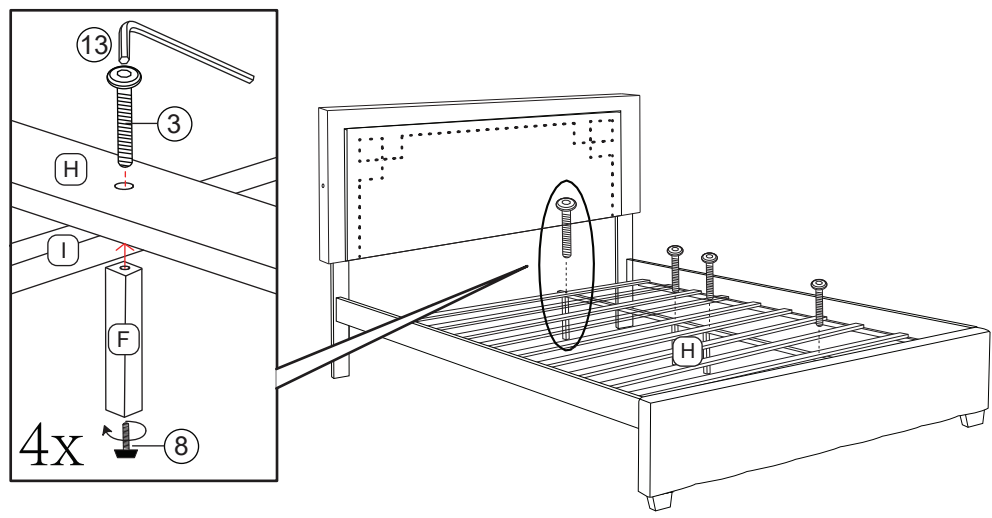

Adjust slat leveling feet to touch floor.

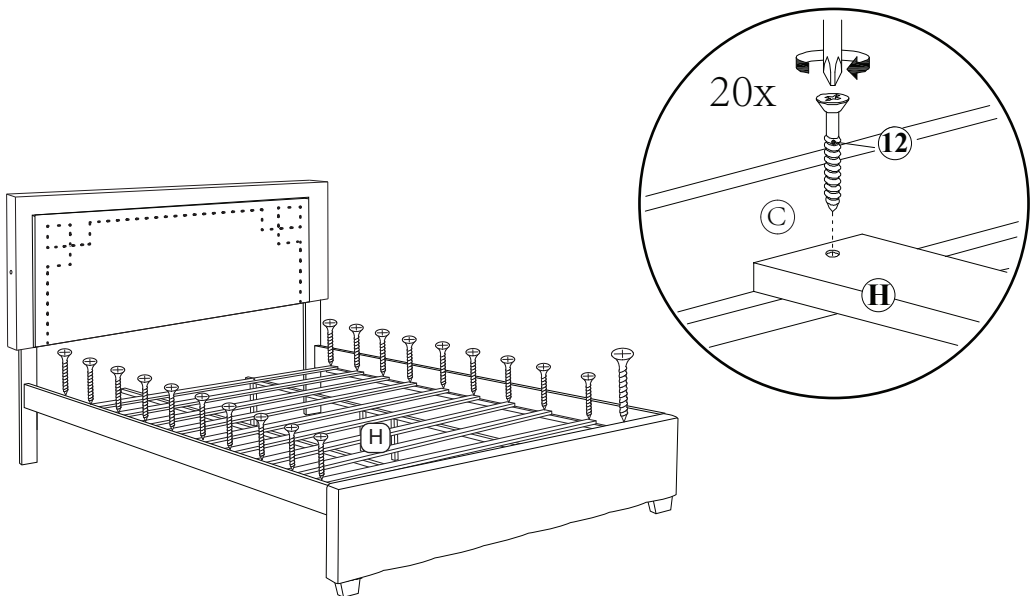

STEP 5

12

20 pcs



STEP 6

Decide the side for drawers

9		17	
8 pcs		8 pcs	

Option 1

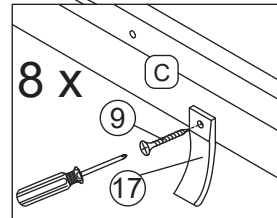
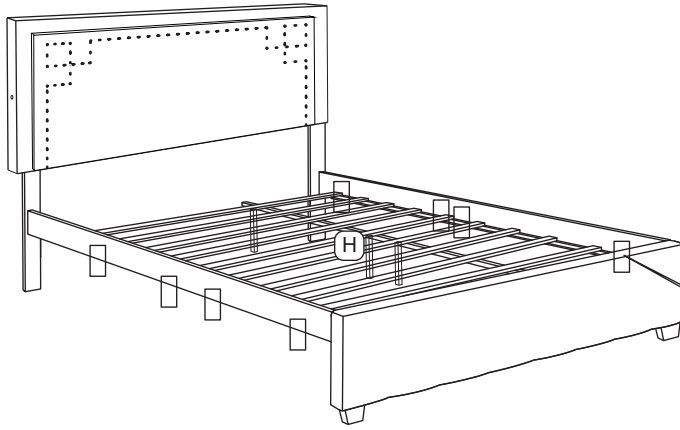

Optional:
Add drawer stopper

STEP 7

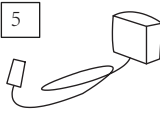
5	
1 pcs	

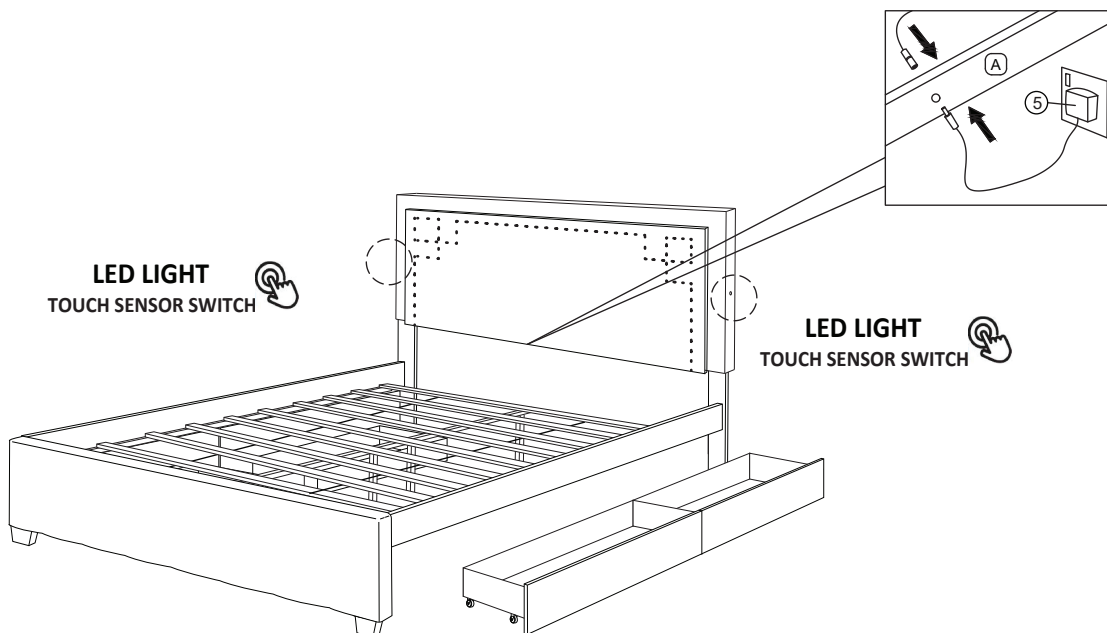

COMPLETED
ASSEMBLY
Lastly, place the drawers inside.

