

# ASSEMBLY INSTRUCTIONS :

ITEM NO : WF308656, WF308657 WF308658

DESCRIPTION : UPHOLSTERED BED

Thank you for purchasing this product & be sure to check all packing material carefully for small part that may have come loose inside the carton during shipment

**Attention :-**

- Bed parts are packed inside the Headboard.
- Before start assembly, please make sure to clean & clear your working area to avoid stain or dirt on product.

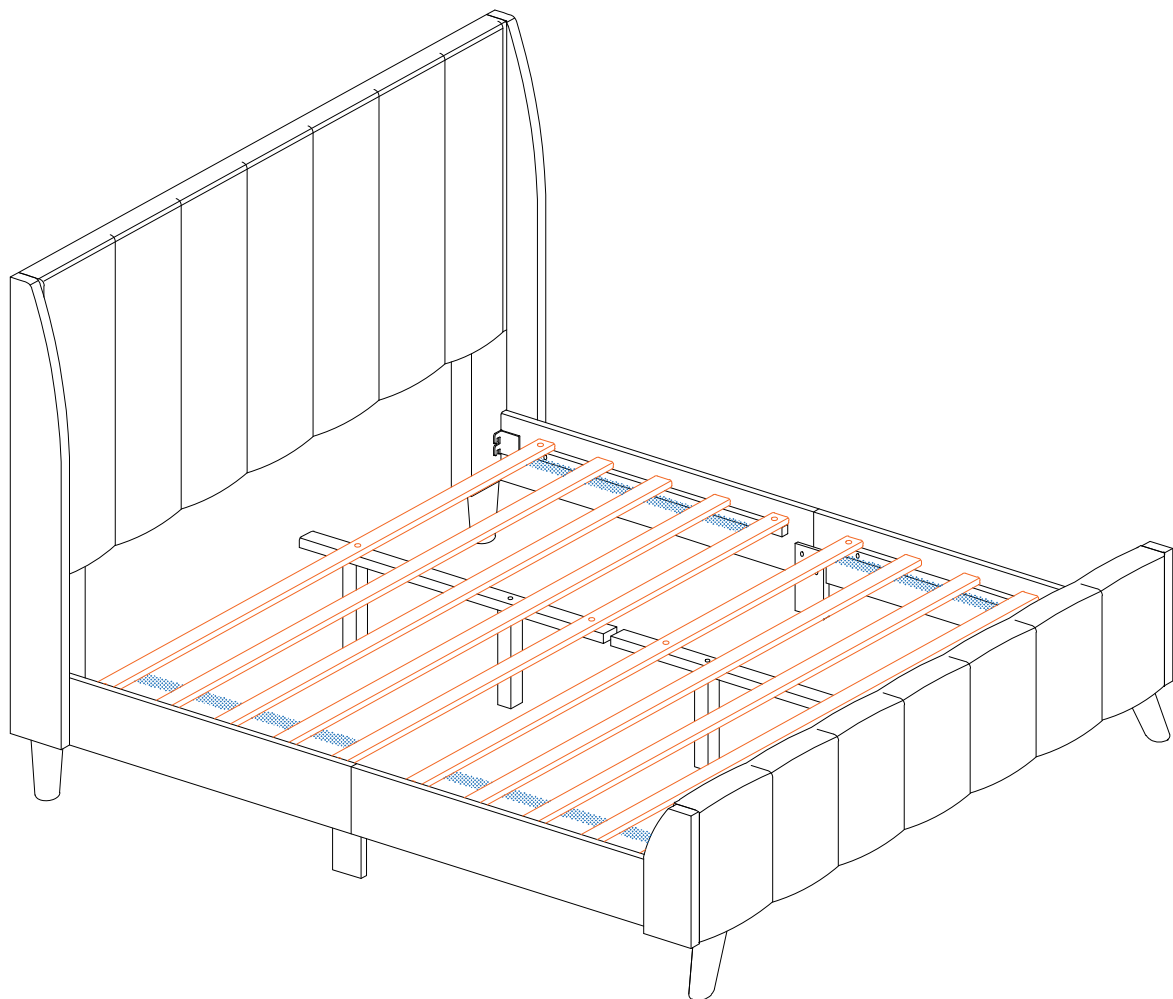

ITEM NO : WF308656 ,WF308657 ,WF308658

# ASSEMBLY INSTRUCTIONS :

## ITEM NO : WF308656, WF308657, WF308658

DESCRIPTION : UPHOLSTERED BED











Thank you for purchasing this product & be sure to check all packing material carefully for small part that may have come loose inside the carton during shipment

MODEL : HARPER BED

### PART LIST :

| NO | DESCRIPTION           | QUANTITY: |
|----|-----------------------|-----------|
| 1  | HEADBOARD             | 1         |
| 2  | FOOTBOARD             | 1         |
| 3  | HEADBOARD LEG         | 2         |
| 4  | FOOTBOARD LEG         | 2         |
| 5  | BED SLATS ( 2 SETS)   | 10        |
| 6  | SIDE RAIL (A)         | 2         |
| 7  | SIDE RAIL (B)         | 2         |
| 8  | SIDE RAIL SUPPORT     | 4         |
| 9  | WINGS HEADBOARD       | 2         |
| 10 | WINGS FOOTBOARD       | 2         |
| 11 | CENTER RAIL           | 2         |
| 12 | CENTER RAIL SUPPORT   | 4         |
| 13 | LEG PILLAR            | 2         |
| 14 | SIDE RAIL SUPPORT LEG | 2         |

### HARDWARE LIST :

| NO | DESCRIPTION  | QUANTITY: |
|----|--|-----------|
| A  | CSK M4 x 16mm     | 8         |
| B  | CSK M4 x 32mm     | 8         |
| C  | JCBB M8 x 20mm    | 8         |
| D  | JCBC M6 x 30mm    | 18        |
| E  | JCBC M6 x 35mm    | 12        |
| F  | JCBC M6 x 50mm    | 8         |
| G  | FLAT WASHER M6    | 34        |
| H  | SPRING WASHER M6  | 34        |
| I  | ALLEN KEY M4      | 1         |
| J  | ALLEN KEY M5      | 1         |
| K  | PLASTIC WASHER   | 4         |

**Important note :**

- Place all wooden part on a clean & smooth surface such as rug or carpet to avoid the part from being scratch.
- Please follow the assembly instruction step by step.
- Do not tighten all screw until the Bed is fully set-up.

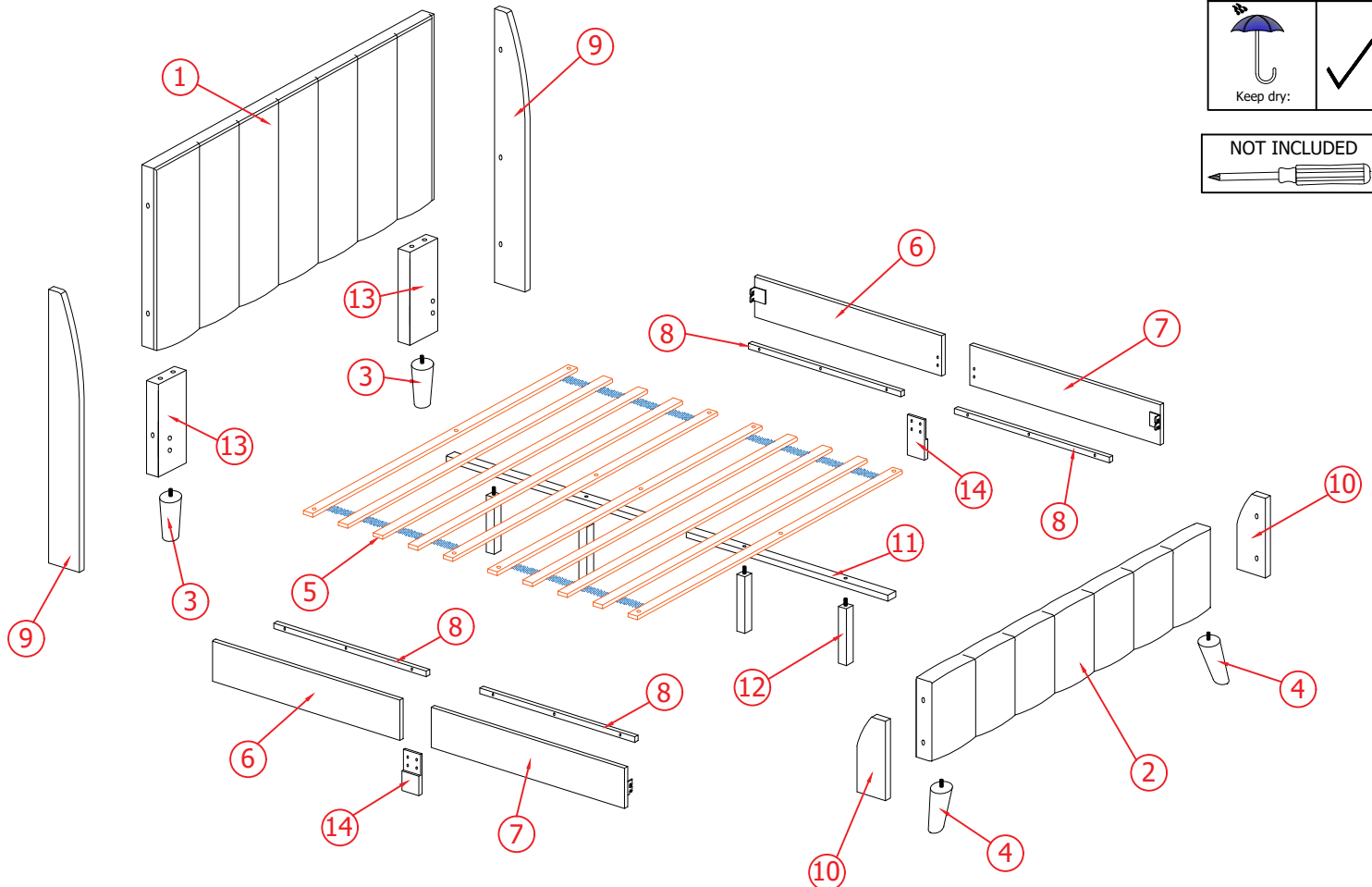
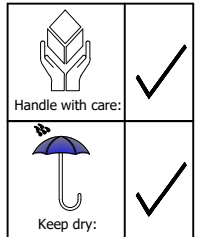

# ASSEMBLY INSTRUCTIONS :

## ITEM NO : WF308656, WF308657, WF308658

### DESCRIPTION : UPHOLSTERED BED

Thank you for purchasing this product & be sure to check all packing material carefully for small part that may have come loose inside the carton during shipment

#### STEP 1 :-

- Attach the FB Leg (4) with Footboard (2) by using Plastic Washer (K)

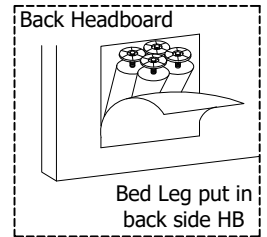
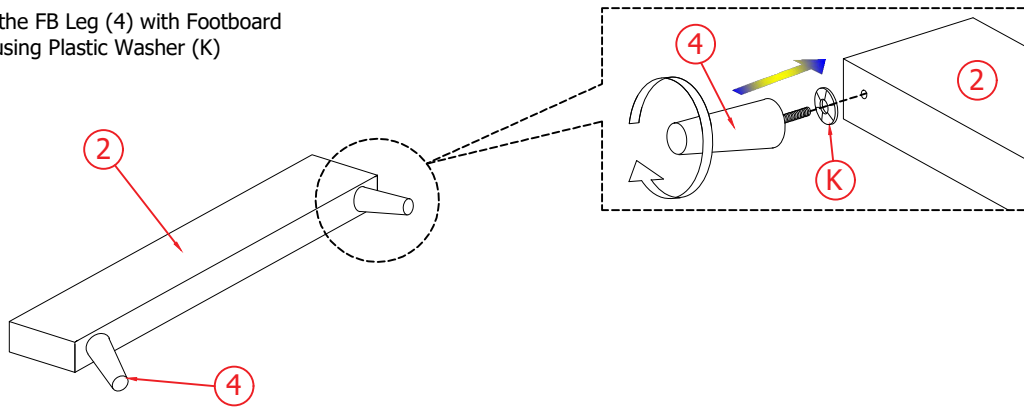

|   |                |  |   |
|---|----------------|--|---|
| K | PLASTIC WASHER |  | 2 |
|---|----------------|--|---|

#### STEP 2 :-

- Attach the Side Rail Support (8) on the side Rail (6)(7). By using the Bolt (E), Spring Washer (H), Flat Washer (G) & Allen key (I).
- Put the Side Rail symmetrical. Then attach the Support side Rail (8) with Side Rail (6)(7) by using the Bolt (D), Spring Washer (H), Flat Washer (G) & Allen key (I).

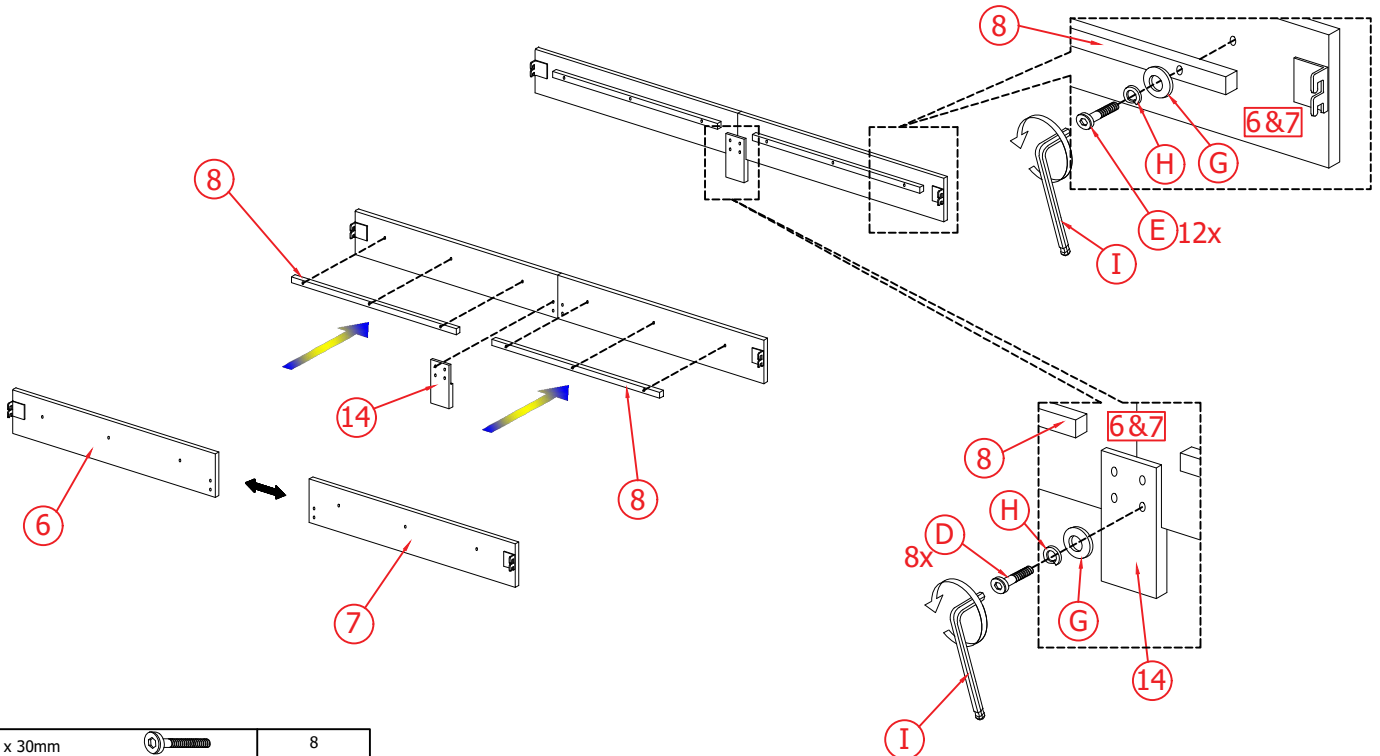

|   |                  |  |    |
|---|------------------|--|----|
| D | JCBC M6 x 30mm   |  | 8  |
| E | JCBC M6 x 35mm   |  | 12 |
| G | FLAT WASHER M6   |  | 20 |
| H | SPRING WASHER M6 |  | 20 |
| I | ALLEN KEY M4     |  | 1  |

# ASSEMBLY INSTRUCTIONS :

ITEM NO : WF308656, WF308657, WF308658

## DESCRIPTION : UPHOLSTERED BED

Thank you for purchasing this product & be sure to check all packing material carefully for small part that may have come loose inside the carton during shipment

### STEP 3 :-

- Attach the HB Leg (3) with Leg Pillar (13) by using Plastic Washer (K)
- Then, Attach the Leg Pillar (13) on Headboard (1) by using the Spring Washer (H), Flat Washer (G), Bolt (F) & tight with Allen key (I).

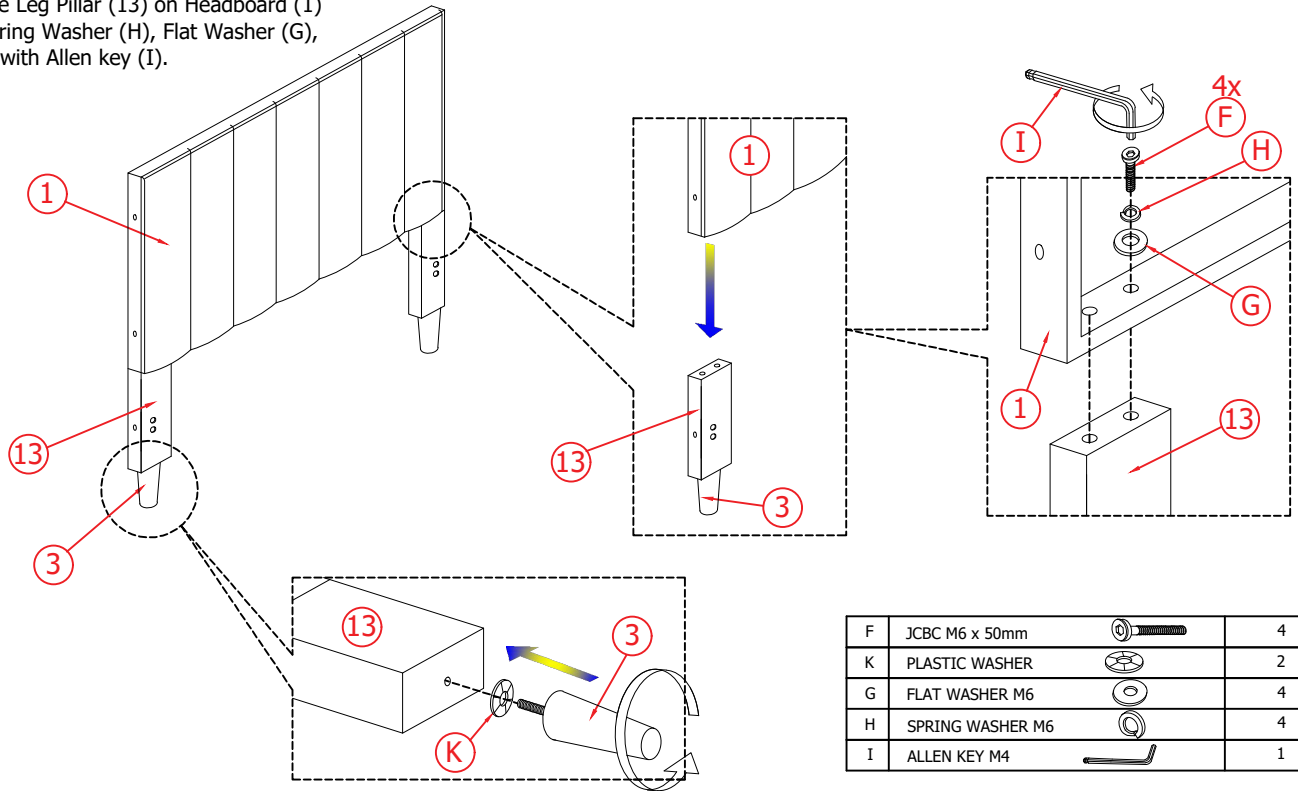

|   |                  |  |   |
|---|------------------|--|---|
| F | JCBC M6 x 50mm   |  | 4 |
| K | PLASTIC WASHER   |  | 2 |
| G | FLAT WASHER M6   |  | 4 |
| H | SPRING WASHER M6 |  | 4 |
| I | ALLEN KEY M4     |  | 1 |

### STEP 4 :-

- Use the Bolts (C) to put on Leg Pillar (13) & Footboard (2) by using hand without tighten it.
- Next, hook the Metal L Bracket on Side Rail (6)(7) on the Bolts (C) & tighten it with Allen key (J).

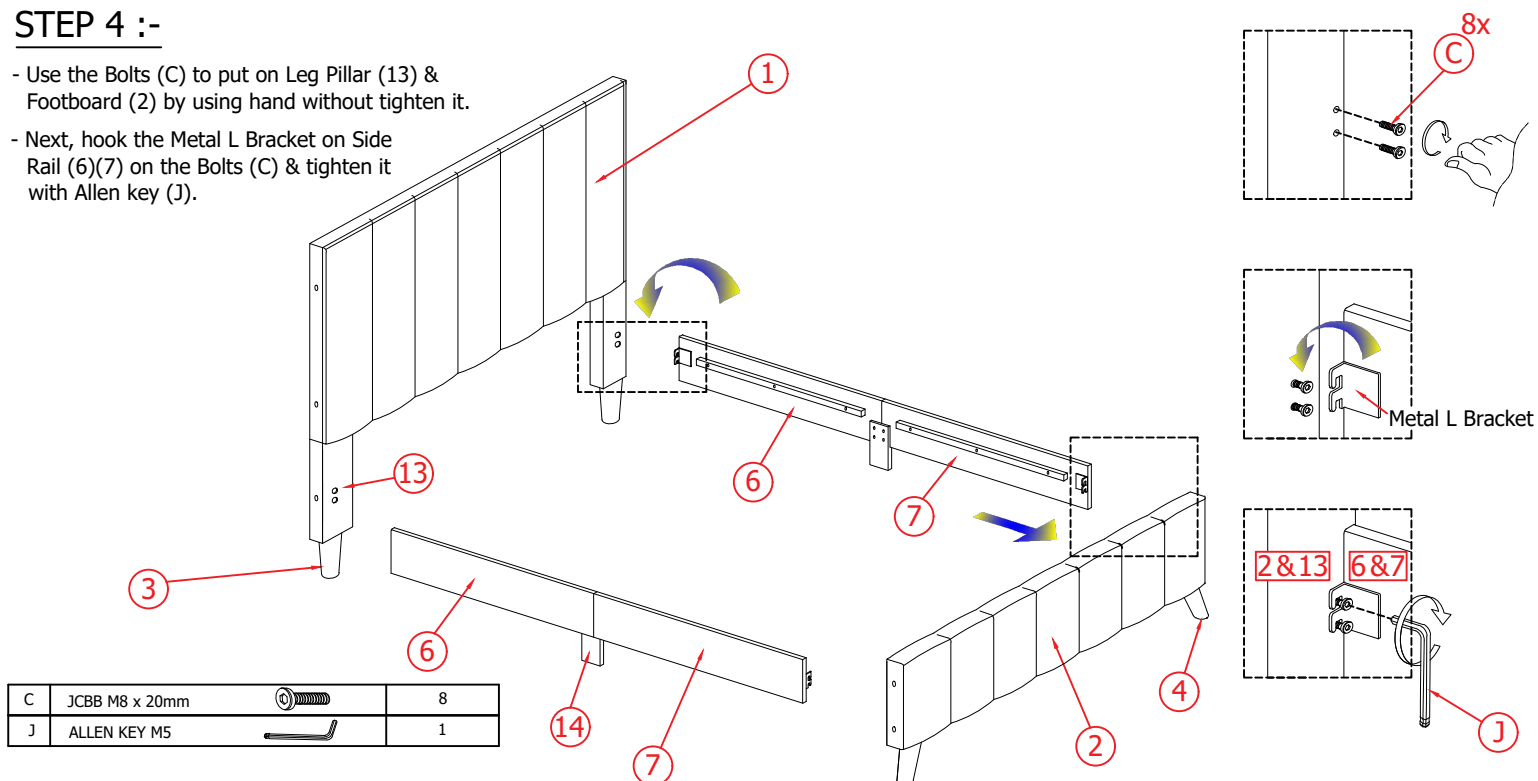

|   |                |  |   |
|---|----------------|--|---|
| C | JCBB M8 x 20mm |  | 8 |
| J | ALLEN KEY M5   |  | 1 |

# ASSEMBLY INSTRUCTIONS :-

ITEM NO : WF308656, WF308657, WF308658

## DESCRIPTION : UPHOLSTERED BED

Thank you for purchasing this product & be sure to check all packing material carefully for small part that may have come loose inside the carton during shipment

### STEP 5 :-

- Attach the Center Rail Support (12) with Bed Center Rail (11) first & use screw (A) to tighten it.

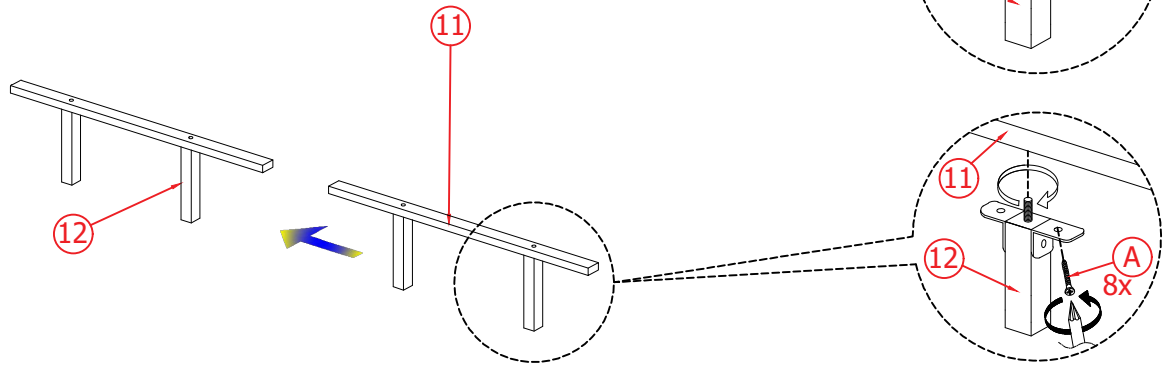



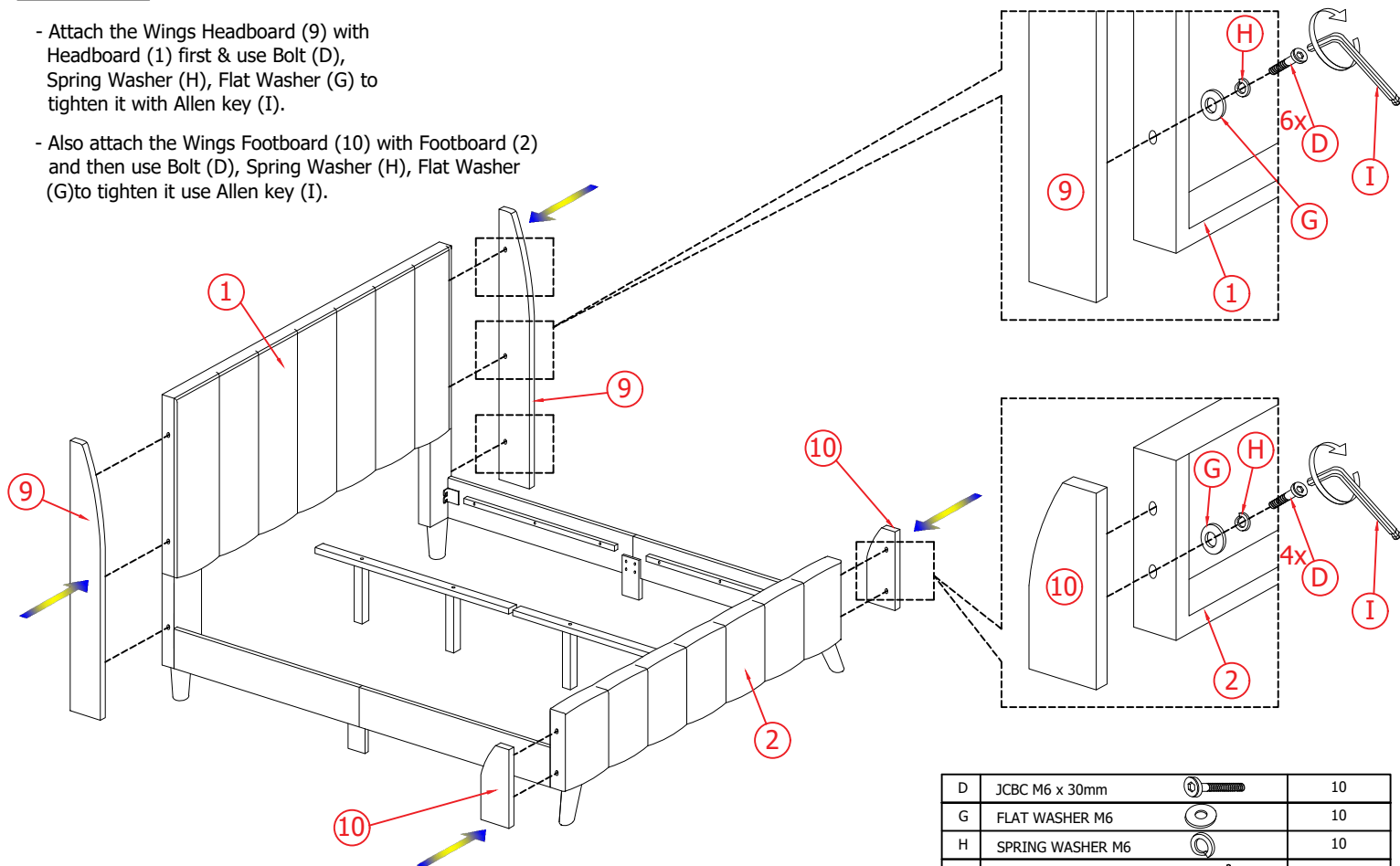

|   |               |   |   |
|---|---------------|---|---|
| A | CSK M4 x 16mm |  | 8 |
|---|---------------|---|---|

### STEP 6 :-

- Attach the Wings Headboard (9) with Headboard (1) first & use Bolt (D), Spring Washer (H), Flat Washer (G) to tighten it with Allen key (I).
- Also attach the Wings Footboard (10) with Footboard (2) and then use Bolt (D), Spring Washer (H), Flat Washer (G) to tighten it use Allen key (I).



|   |                  |   |    |
|---|------------------|---|----|
| D | JCBC M6 x 30mm   |  | 10 |
| G | FLAT WASHER M6   |  | 10 |
| H | SPRING WASHER M6 |  | 10 |
| I | ALLEN KEY M4     |  | 1  |

# ASSEMBLY INSTRUCTIONS :

ITEM NO : WF308656, WF308657, WF308658

## DESCRIPTION : UPHOLSTERED BED

Thank you for purchasing this product & be sure to check all packing material carefully for small part that may have come loose inside the carton during shipment

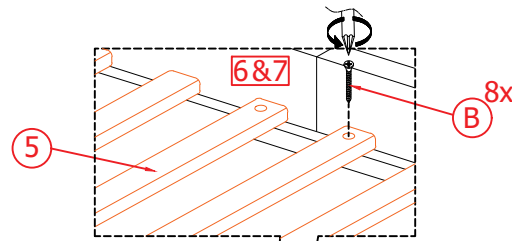

### STEP 7 :-

- Put the Slat (5) on the Side Rail (6)(7) of the bed to be neat, then tighten it by using Screw (B).

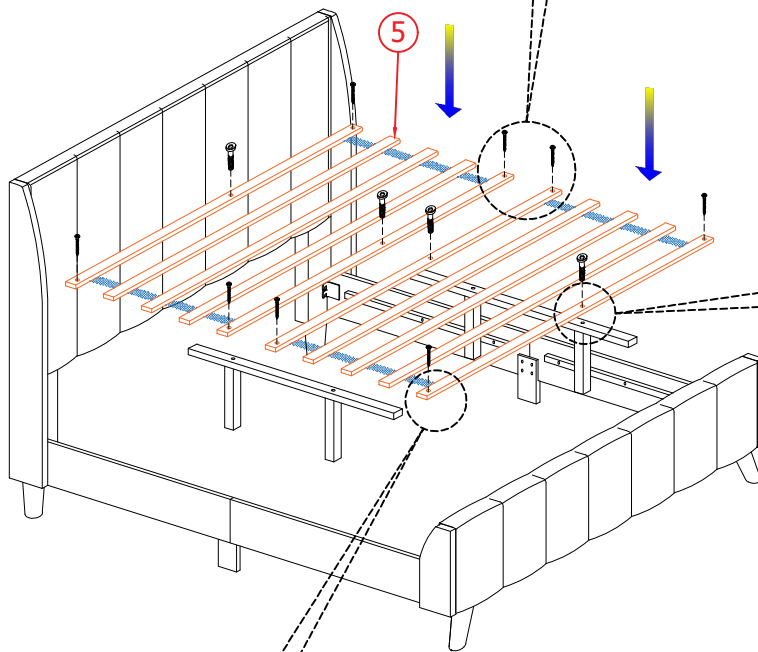
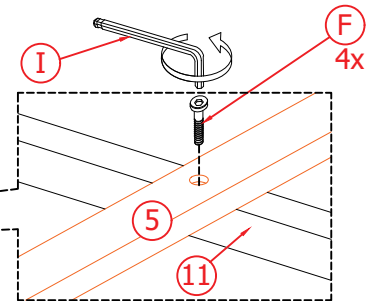

- Afterwards, attach Bed Center Rail (11) with Slat (5) by using the Bolt (F) & Allen key (I).



|   |                |   |   |
|---|----------------|---|---|
| B | CSK M4 x 32mm  |  | 8 |
| F | JCBC M6 x 50mm |  | 4 |
| I | ALLEN KEY M4   |  | 1 |