



**Item # : CW700PT**

**Description: Caswell Counter Table**

**Product Size : 54"x 54"x 36"H**

Your furniture purchase is an investment. Furniture can last life times, with a minimum amount of effort. Here are a few tips to properly care for your furniture, ensuring that it looks great year after year.

**Wood Furniture Maintenance:**

- Always dust, wipe, and clean with the grain of the wood.
- Dust with a soft cloth. Dust will scratch the furniture surface if not removed properly.
- Use the same type of polish consistently as interchanging oil-based and wax-based polishes will cause a build-up and result in a foggy or cloudy appearance.
- If a polished surface become foggy, rub it with a cloth dipped in a solution of one tablespoon vinegar to one quart of water .
- Rub softly with the grain until the surface is completely dry.
- Soap and water are not advisable for wood surfaces. Water can penetrate the finish and raise the grain on wood, causing damage.
- Remember to change dusting cloths frequently as dirty cloths may scratch your furniture's surface .
- The Enemies of Wood:
- Moisture is wood's worst enemy. Liquid spills should be gently wiped up immediately. Coasters should be used under all beverages.
- Do not allow rubber or vinyl materials to lie on the furniture. Chemicals in rubber may leave a stain. Put a strip of felt or leather under accessories that have rubber or vinyl.
- Heat creates a chemical change in the furniture's finish, which results in a white spot. Use protective pads under hot dishes, appliances, etc.
- Sunlight's ultraviolet rays can damage the finish of furniture. Do not place furniture directly against heater or radiator and do not place in the path of hot streams of air from central heating. This will cause extreme localized drying of the wood.

**High Gloss Resin Table Maintenance:**

- Resin tabletops have approximately 1/8" of a resin coat on the top face of the table, which will resist ice, water, wine, liquor, food, cleaning fluids, and warm or hot liquids; however, cups, glasses, etc, containing hot liquids should not be left on the table without a coaster for protection.
- Resin tabletops will scratch just the same as any other glossy surface and basic precautions should be taken.
- For lasting shine, the resin should be waxed with a car wax the does not contain silicon. Maintaining this wax build-up will result in a high gloss shine.
- When wiping down the table, a soft, clean rag should be used. Do not use a heavy paper.

**Granite Top Maintenance:**

- The surface of granite on your table has been polished or sealed to create a generally non-porous surface. The stone has many natural characteristics including: veining, hairline cracks, and color variations- which make up the stone's beauty.
- To maintain the beauty of your granite:
  - Protect surfaces from scratching, staining and etching by
    - \*Keeping them free of debris or sharp objects.
    - \*Wiping up spills immediately.
    - \*Avoiding contact with chemicals (particularly acid -based materials)
  - Clean with pH neutral products or those especially formulated for use on stone.
  - It is not recommended to use a water - based solvent for dark granite as it remove the polish from the surface.
  - After a period of use, apply a penetrating sealer to prevent contaminants from being absorbed into the stone.
  - Remove stains with special absorbent poultices formulated for use on stone.
  - Renew the surface on polished granite (granite with a high gloss surface) by buffing with special stone polish, powder or cream.
  - Do not use granite polish on granite with a matte finish, which has been honed rather than polished. (Penetrating sealer may be used on both polished and honed granite).







**Marble Top Maintenance :**

- Marble may be stone, but it is porous stone and can stain easily. Treating marble surfaces the same as wood surfaces is a great rule of thumb.
- It is recommended to seal the tops on a regular basis (every 6 to 12 months) A good quality stone sealer can be purchased from any tiles/stone store or any homecare store and should be applied according to the manufacture's recommendation.
- When sealed properly, marble tops can be used indoors and outdoors and can withstand any weather conditions except internal freezing. Snow or freezing rain will penetrate the table and cause cracks.

**Caring for the Fabric on Upholstered Furniture:**

- Frequent vacuuming of the entire upholstered area will prevent dust from settling in to the fibers.
- Professional cleaning is always recommended for all upholstered pieces.
- Always pre -test a small area of fabric in a inconspicuous area when cleaning before proceeding.
- Do not use cleaning products containing brightening agents.

**VERY IMPORTANT !!**

<p><b>NEVER</b> USE GLASS CLEANERS ON FINISHED SURFACE AMMONIA WILL CHEMICALLY ATTACK THE FINISH.</p>	<p>DO NOT WRITE DIRECTLY ON SURFACE</p>  <p>PREVENT MARKING</p>	<p>DO NOT PLACE DIRECTLY IN SUNLIGHT</p>  <p>PREVENT FADING</p>	<p>DO NOT WRITE PLACEMATS WITH RUBBER BASES</p>  <p>PREVENT DISCOLORING</p>
<p><b>NEVER</b> ALLOW LIQUIDS OF ANY KIND TO LINGER ON SURFACE ABSORPTION CAUSES THE WOOD TO WARP AND THE FINISH TO BE LAMINATE.</p>	<p>DO NOT USE COMMERCIAL POLISHES AND WAXES</p>  <p>PREVENT YELLOWING</p>	<p>DO NOT PLACE HOT POTS, ETC ON SURFACE</p>  <p>PREVENT DAMAGE TO FINISH</p>	<p>DO NOT USE COMMERCIAL POLISHES AND WAXES</p>  <p>PREVENT SPLITTING</p>

# CW700PT

## ASSEMBLY INSTRUCTIONS

### STEP 1

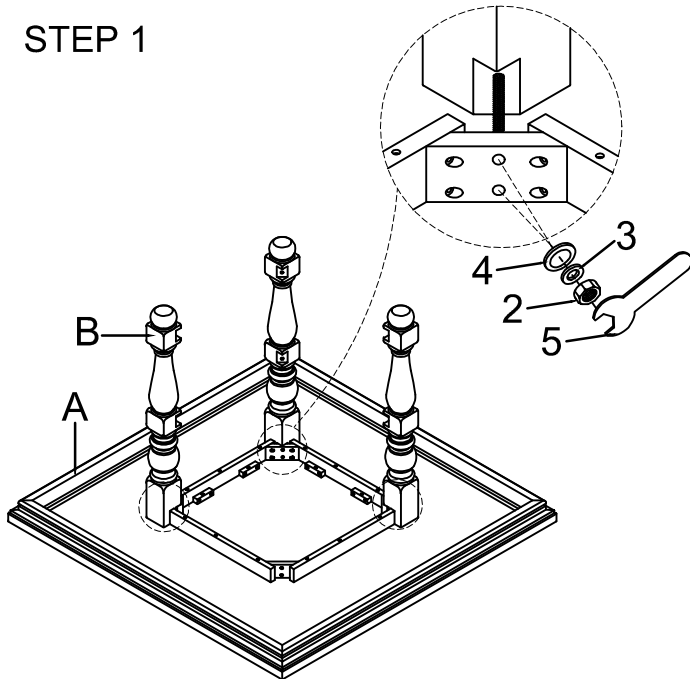

### STEP 2

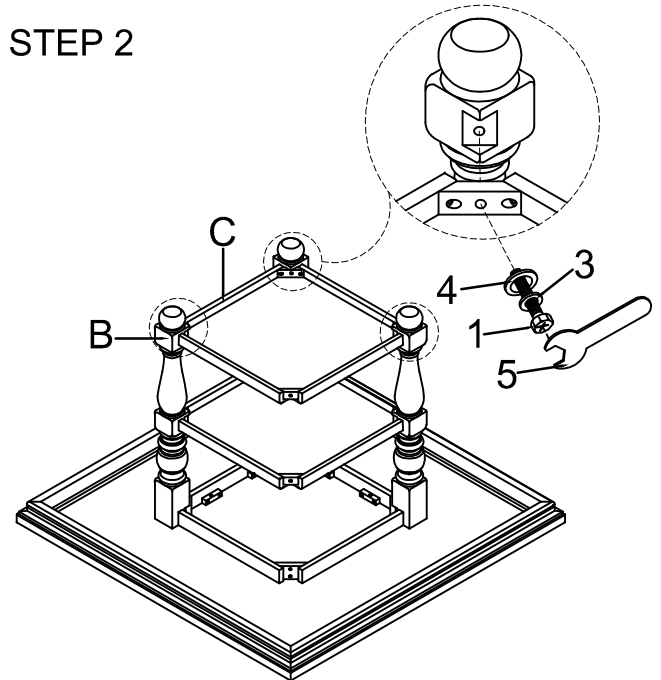

### STEP 3

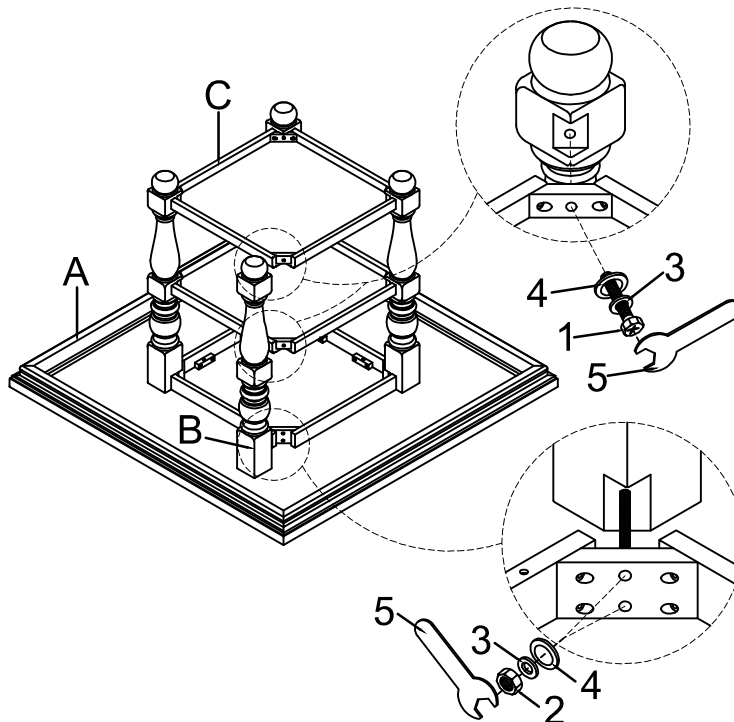

Step 1: Turn Table Top (A) on the floor with a piece of cloth or carpet underneath to prevent finish from scratching. Attach Leg (B) to Table top(A) and assemble by inserting Flat washer(4), Spring washer(3), Hex nut (2), then tighten with Wrench (5). Repeat the same steps for the other two legs. Do not fully tighten.



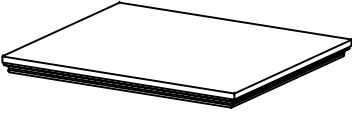
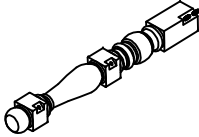
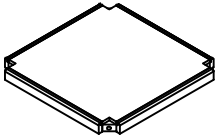

Step 2: Attach Shelf (C) to the middle and end of leg (B) by inserting Flat washer (4), Spring washer (3), Bolt (1), then tighten with Wrench (5). Do not fully tighten.

Step 3: Attach the last Leg (B) to Table top (A) using Flat washer (4), Spring Washer (3), Hex nut (2) and tighten with Wrench (5), do not fully tighten. Attach the Leg (B) to the Shelf (C) by inserting Flat washer (4), Spring washer (3), Bolt (1) and tighten with Wrench (5). Fully tighten all bolts and hex nuts at this time, turn the table to upright position. Assembly product is now complete.

# PARTS LIST

(A) TABLE TOP (1PC)	(B) LEG (4PCS)	(C) SHELF (2PCS)
		

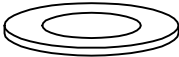
## HARDWARE PACK # : PCW700PTH

NO.	DESCRIPTION	DIMENSION	Q' TY
1	BOLT	 $\text{Ø}5/16" \times 57\text{MM}$	8PCS
2	HEX NUT	 $\text{Ø}5/16" * 6\text{MM}$	8PCS
3	SPRING WASHER	 $5/16 \times \text{Ø}13 \times 1.2\text{mm}$	16PCS
4	FIAT WASHER	 $5/16 \times \text{Ø}19 \times 1.8\text{mm}$	16pcs
5	OPEN WRENCH 12MM	 12MM	1PC

# PARTS FOR CW700PT

## COMPLETE HARDWARE # : PCW700PTH

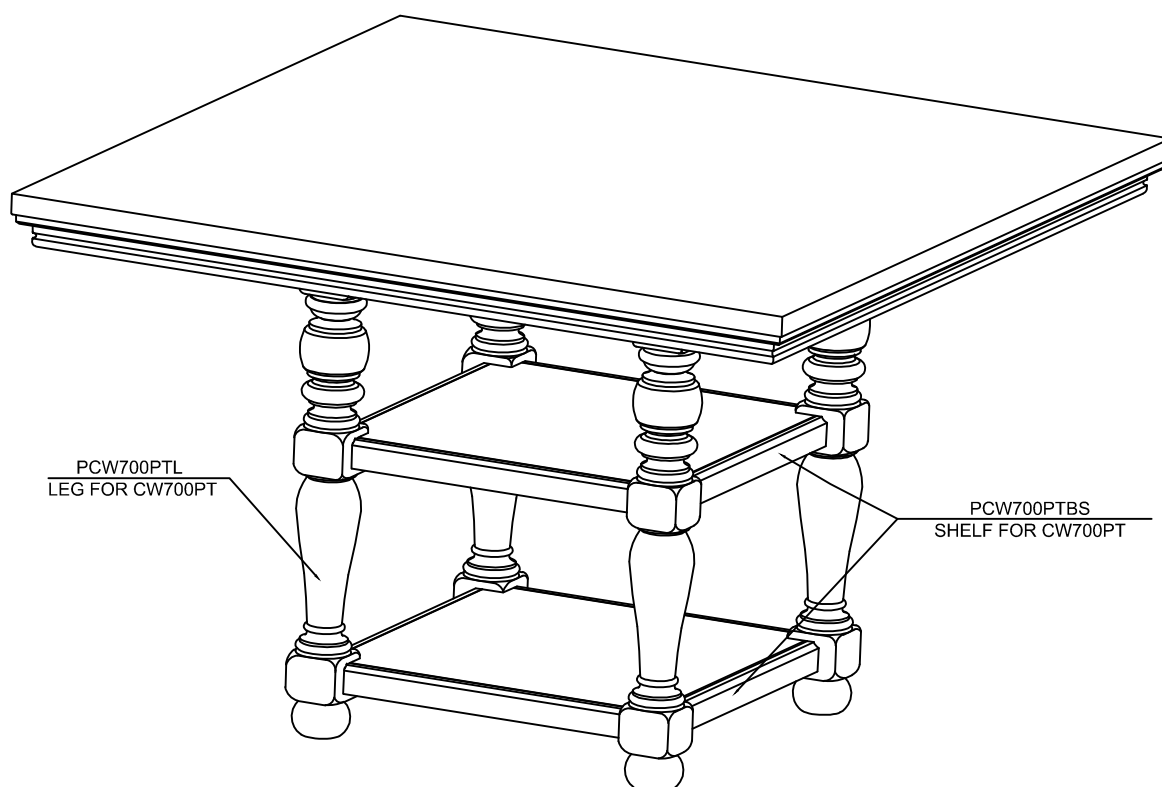

### PRODUCT DETAILS

TABLE TOP	MDF/POPLAR/CHERRY VENEER
LEG FRAME	CASHEW WOOD
PRODUCT SIZE	54"x 54"x 36"H
CARTON SIZE	58.25" x 58.25" x 8.25"H
NET WEIGHT	134.2 LBS
GROSS WEIGHT	151.8 LBS
CU.FT	16.20'

**MADE IN VIETNAM**



**Item # : CW700CC**

**Description: Caswell Counter Chair**

**Product Size : 20" x 24" x 45" H**

Your furniture purchase is an investment. Furniture can last life times, with a minimum amount of effort. Here are a few tips to properly care for your furniture, ensuring that it looks great year after year.

#### Wood Furniture Maintenance:

- Always dust, wipe, and clean with the grain of the wood.
- Dust with a soft cloth. Dust will scratch the furniture surface if not removed properly.
- Use the same type of polish consistently as interchanging oil-based and wax-based polishes will cause a build-up and result in a foggy or cloudy appearance.
- If a polished surface become foggy, rub it with a cloth dipped in a solution of one tablespoon vinegar to one quart of water .
- Rub softly with the grain until the surface is completely dry.
- Soap and water are not advisable for wood surfaces. Water can penetrate the finish and raise the grain on wood, causing damage.
- Remember to change dusting cloths frequently as dirty cloths may scratch your furniture's surface .
- The Enemies of Wood:
  - Moisture is wood's worst enemy. Liquid spills should be gently wiped up immediately. Coasters should be used under all beverages.
  - Do not allow rubber or vinyl materials to lie on the furniture. Chemicals in rubber may leave a stain. Put a strip of felt or leather under accessories that have rubber or vinyl.
  - Heat creates a chemical change in the furniture's finish, which results in a white spot. Use protective pads under hot dishes, appliances, etc.
  - Sunlight's ultraviolet rays can damage the finish of furniture. Do not place furniture directly against heater or radiator and do not place in the path of hot streams of air from central heating. This will cause extreme localized drying of the wood.

#### High Gloss Resin Table Maintenance:

- Resin tabletops have approximately 1/8" of a resin coat on the top face of the table, which will resist ice, water, wine, liquor, food, cleaning fluids, and warm or hot liquids; however, cups, glasses, etc, containing hot liquids should not be left on the table without a coaster for protection.
- Resin tabletops will scratch just the same as any other glossy surface and basic precautions should be taken.
- For lasting shine, the resin should be waxed with a car wax that does not contain silicon. Maintaining this wax build-up will result in a high gloss shine.
- When wiping down the table, a soft, clean rag should be used. Do not use a heavy paper.

#### Granite Top Maintenance:

- The surface of granite on your table has been polished or sealed to create a generally non-porous surface. The stone has many natural characteristics including: veining, hairline cracks, and color variations- which make up the stone's beauty.
- To maintain the beauty of your granite:
- Protect surfaces from scratching, staining and etching by
    - \*Keeping them free of debris or sharp objects.
    - \*Wiping up spills immediately.
    - \*Avoiding contact with chemicals (particularly acid -based materials)
  - Clean with pH neutral products or those especially formulated for use on stone.
  - It is not recommended to use a water - based solvent for dark granite as it remove the polish from the surface.
  - After a period of use, apply a penetrating sealer to prevent contaminants from being absorbed into the stone.
  - Remove stains with special absorbent poultices formulated for use on stone.
  - Renew the surface on polished granite (granite with a high gloss surface) by buffing with special stone polish, powder or cream.
  - Do not use granite polish on granite with a matte finish, which has been honed rather than polished. (Penetrating sealer may be used on both polished and honed granite).

#### Marble Top Maintenance :

- Marble may be stone, but it is porous stone and can stain easily. Treating marble surfaces the same as wood surfaces is a great rule of thumb.
- It is recommended to seal the tops on a regular basis (every 6 to 12 months) A good quality stone sealer can be purchased from any tiles/stone store or any homeware store and should be applied according to the manufacture's recommendation.
  - When sealed properly, marble tops can be used indoors and outdoors and can withstand any weather conditions except internal freezing. Snow or freezing rain will penetrate the table and cause cracks.

#### Caring for the Fabric on Upholstered Furniture:

- Frequent vacuuming of the entire upholstered area will prevent dust from settling in to the fibers.
- Professional cleaning is always recommended for all upholstered pieces.
- Always pre -test a small area of fabric in a inconspicuous area when cleaning before proceeding.
- Do not use cleaning products containing brightening agents.

## VERY IMPORTANT !!

#### NEVER

USE GLASS CLEANERS ON FINISHED SURFACE AMMONIA WILL CHEMICALLY ATTACK THE FINISH.

DO NOT WRITE DIRECTLY ON SURFACE



PREVENT MARKING

DO NOT PLACE DIRECTLY IN SUNLIGHT



PREVENT FADING

DO NOT WRITE PLACEMATS WITH RUBBER BASES



PREVENT DISCOLORING

#### NEVER

ALLOW LIQUIDS OF ANY KIND TO LINGER ON SURFACE ADSORPTION CAUSES THE WOOD TO WARP AND THE FINISH TO BE LAMINATE.

DO NOT USE COMMERCIAL POLISHES AND WAXES



PREVENT YELLOWING

DO NOT PLACE HOT POTS, ETC ON SURFACE



PREVENT DAMAGE TO FINISH

DO NOT USE COMMERCIAL POLISHES AND WAXES



PREVENT SPLITTING

# CW700CC

## ASSEMBLY INSTRUCTIONS

DO NOT FULLY TIGHTEN BOLTS AND SCREWS UNTIL THE ENTIRE ITEM IS COMPLETELY ASSEMBLED

### STEP 1:

Turn the Chair Back (A) on the floor with a piece of cloth or carpet underneath to prevent finish from scratching.

Attach Seat Box w/ Seat Cushion (B) to the Chair Back (A) by inserting Flat Washer (2), Spring Washer (1), Long Bolt (3) into the holes at the corner block of the Seat Box w/Seat Cushion (B), insert Flat Washer (2), Spring Washer(1), Short Bolt (4) into the rear bar of the seat frame. Tighten by Wrench (6).

Do not fully tighten.

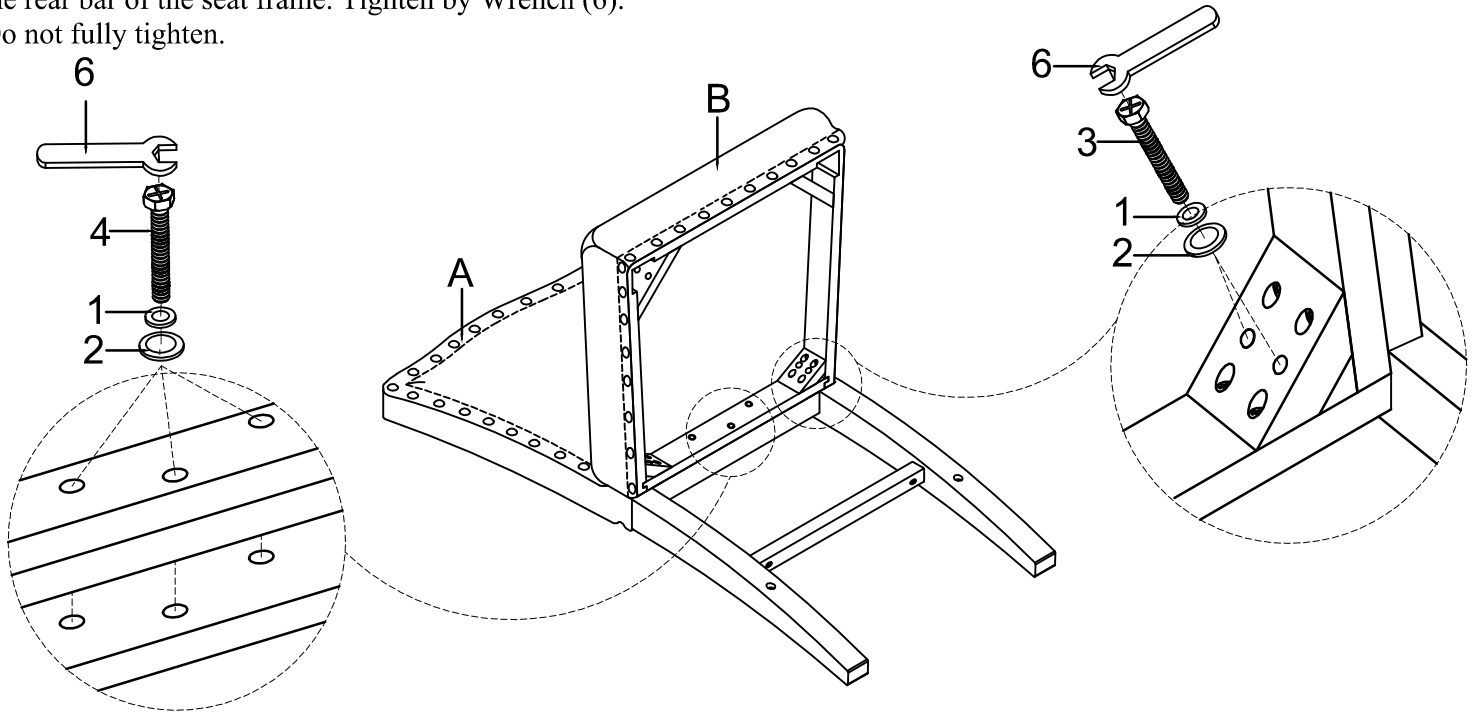

### STEP 2:

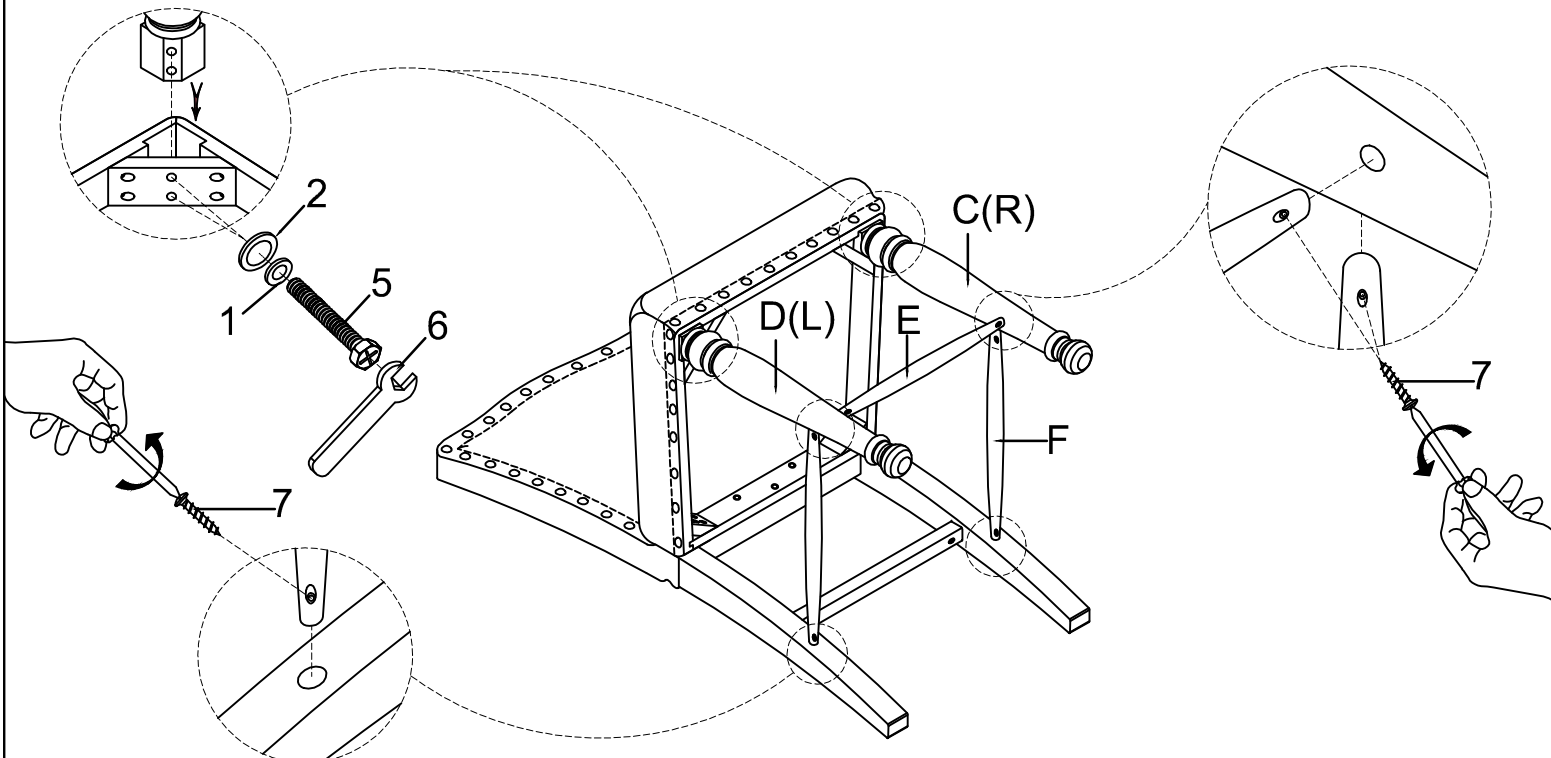

Attach Right Front Leg (C) & Left Front Leg (D) to the Seat Box W/ Seat Cushion (B) by using Flat Washer (2), Spring Washer (1), Medium Bolt (5), secure by Wrench (6). Do not fully tighten. Insert Front Stretcher (E) and Side Stretcher (F) into the hole of legs and chair back, tighten with Screw (7). Fully tighten all bolts at this time.

Assembly product is now complete.





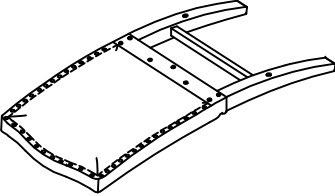
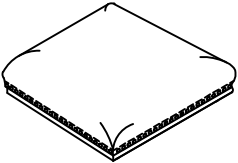
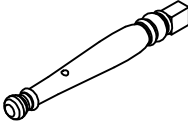
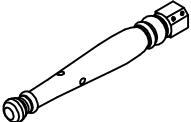

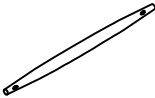

# PARTS LIST

P3/4

(A) CHAIR BACK (1PC)	(B) SEAT BOX W/ SEAT CUSHION (1PC)	(C) RIGHT FRONT LEG (1PC)	(D) LEFT FRONT LEG (1PC)
			
		(E) FRONT STRETCHER (1PC)	(F) SIDE STRETCHER (2PCS)
			

## HARDWARE PACK #: PCW700CCH

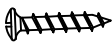
No	Description			Q'TY
1	Spring Washer		5/16xØ13x1.2mm	11 pcs
2	Flat Washer		5/16xØ19x1.8mm	11 pcs
3	Long Bolt		Ø5/16"x80mm	4 pcs
4	Short Bolt		Ø5/16"x40mm	3 pcs
5	Medium Bolt		Ø5/16"57mm	4 pcs
6	Wrench		Ø5/16"x90mm	1 pc
7	Screw		8x38mm	6 pcs

# PARTS FOR CW700CC

## COMPLETE HARDWARE #: PCW700CCH

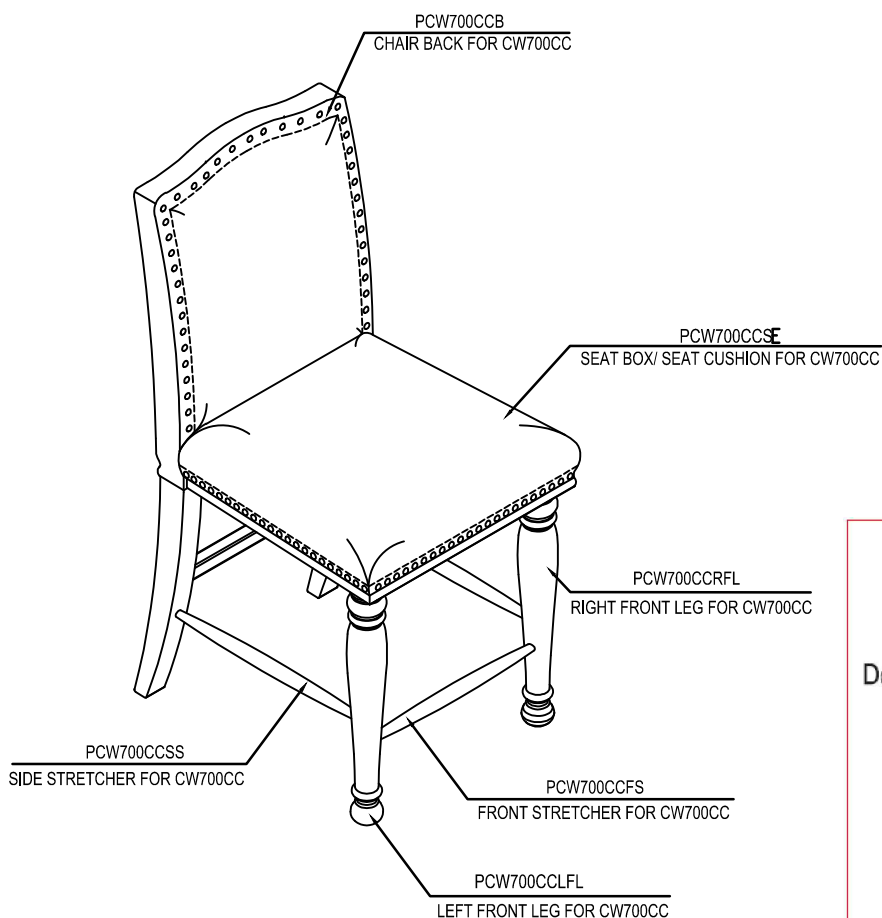

**FABRIC CONTENT : POLYESTER 100%**  
 This fabric is not machine washable.  
 Allow +/-3% residual shrinkage  
 Do not use cleaning products containing brightening agents

Do not mix fabric of different colors.  
 The fabric is suitable for drapery and upholstery



### PRODUCT DETAILS

BACK	RUBBER +PINE
SEAT BOX	RUBBER
LEG	RUBBER WOOD
PRODUCT SIZE	20" x 24" x 45" H
CARTON SIZE	46.5" x 14" x 20.5" H
CUFT/CTN	7.72'
NET WEIGHT	39.6 LBS
GROSS WEIGHT	48.4 LBS

MADE IN VIET NAM