

# Outdoor Storage with Shelves

SKU: LTFA5274



# parts and components I

---

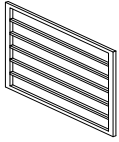

① 1X

Aluminum  
Side Sheet

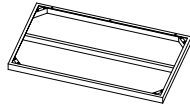

② 1X

Aluminum  
Worktop

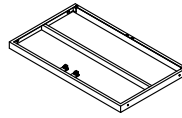

③ 1X

Aluminum  
Middle Worktop

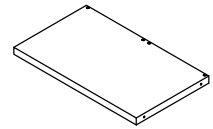

④ 1X

Aluminum  
Base Plate

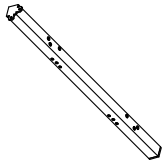

⑤ 1X

Aluminum Leg

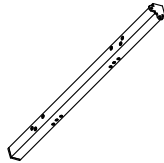

⑥ 1X

Aluminum Leg

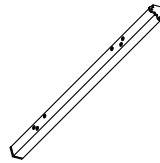

⑦ 1X

Aluminum Leg

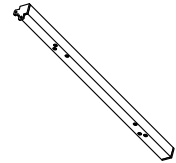

⑧ 1X

Aluminum Leg



⑨ 8X

Bracket

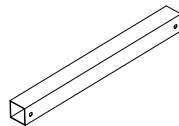

⑩ 4X

Aluminum  
Crosspiece

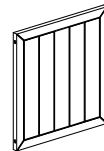

⑪ 2X

Aluminum  
Sidewall

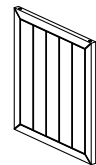

⑫ 2X

Aluminum  
Backwall

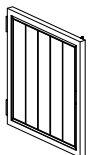

⑬ 1X

Aluminum  
Left Door

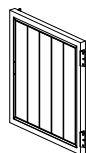

⑭ 1X

Aluminum  
Right Door

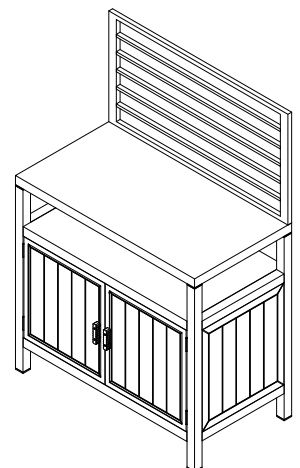

# parts and components I

---

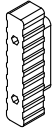

⑮ 2X  
Handle

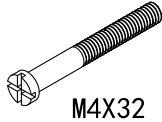

⑯ 4X  
M4X32



⑰ 4X  
M4

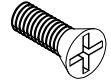

⑱ 12X  
M4\*12

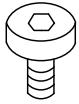

⑲ 40X  
M6X15



⑳ 10X  
M6X18

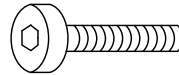

㉑ 3X  
M6X55

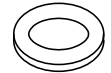

㉒ 13X  
D6

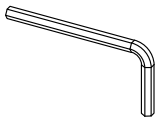

㉓ 1X

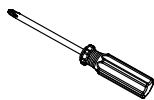

㉔ 1X



㉕ 1X

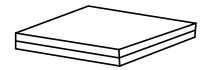

㉖ 1X

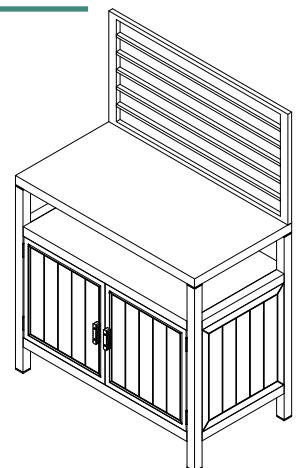

# Step 1



⑤ 1X

Aluminum Leg



⑥ 1X

Aluminum Leg



⑦ 1X

Aluminum Leg



⑧ 1X

Aluminum Leg



⑨ 8X

Bracket



M6X15

⑲ 16X

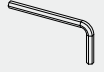

⑳ 1X

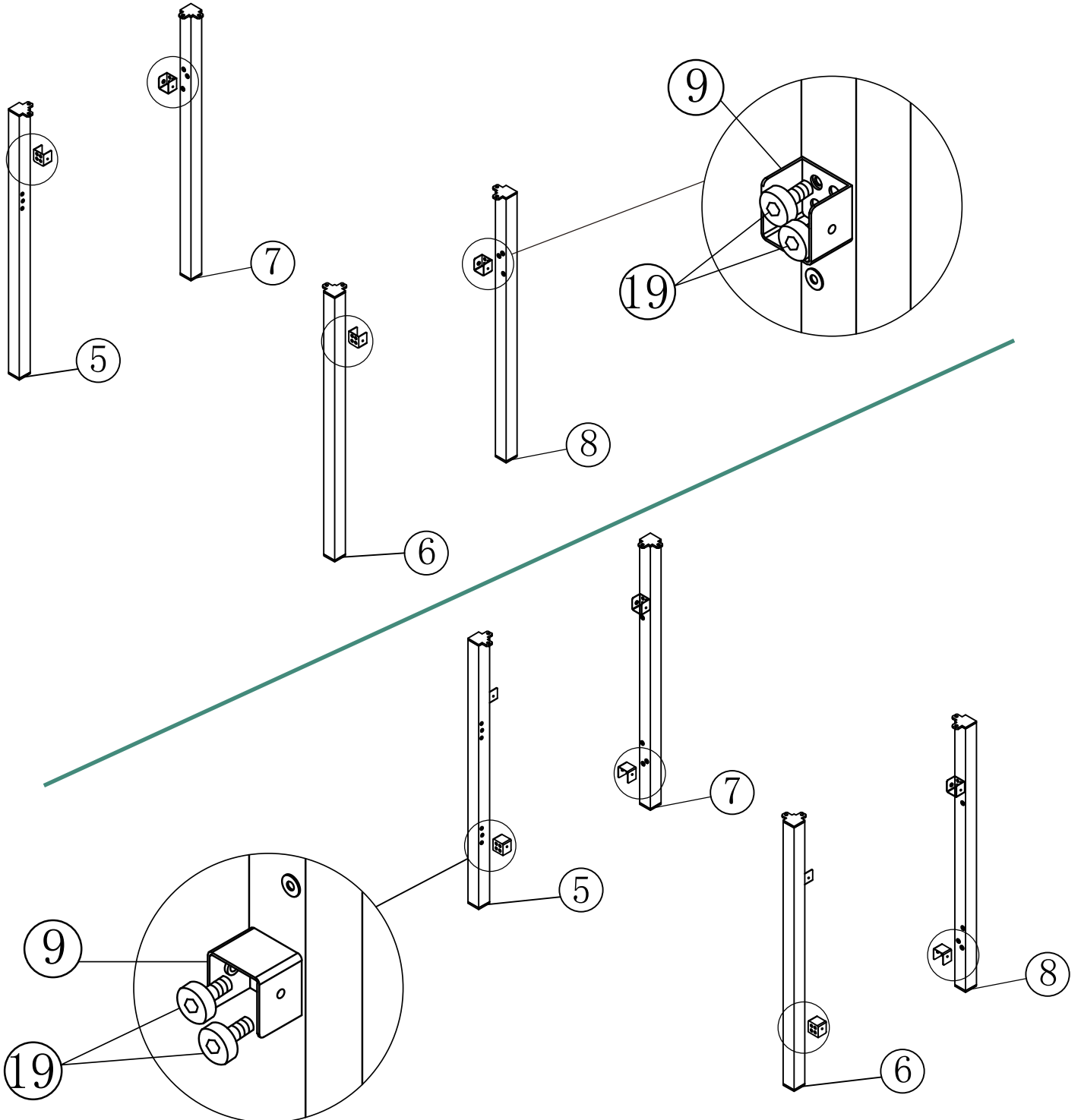

## Step 2

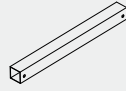

⑩ 4X

Aluminum Crosspiece

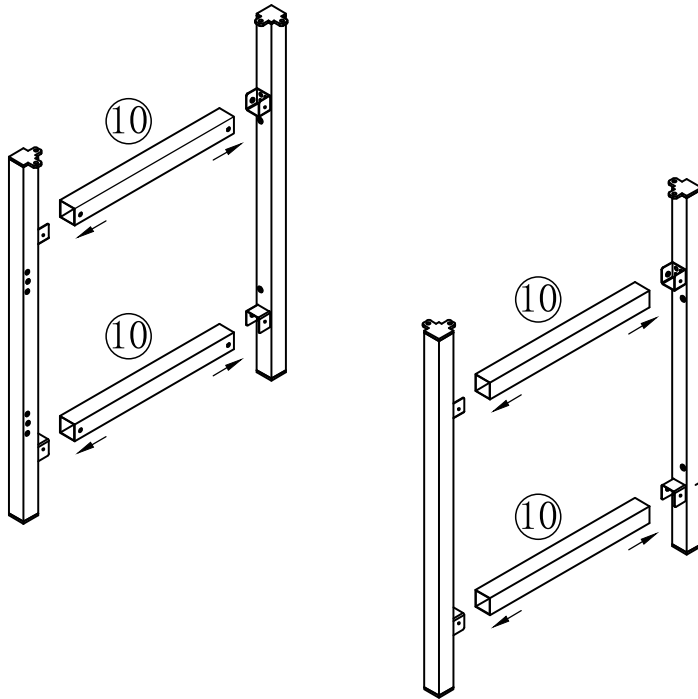

## Step 3



⑪ 2X

Aluminum Sidewall



M6X15

⑲ 8X

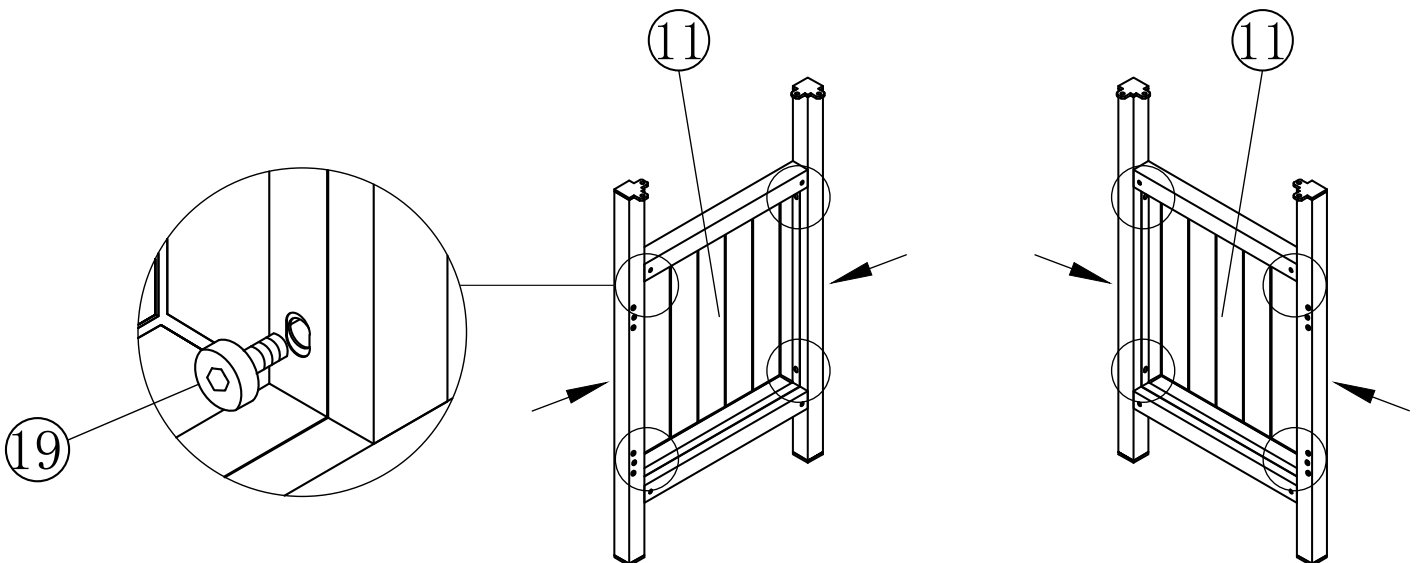

# Step 4

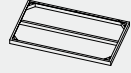

② 1X  
Aluminum Worktop



M6X18  
⑳ 8X



D6  
㉒ 8X

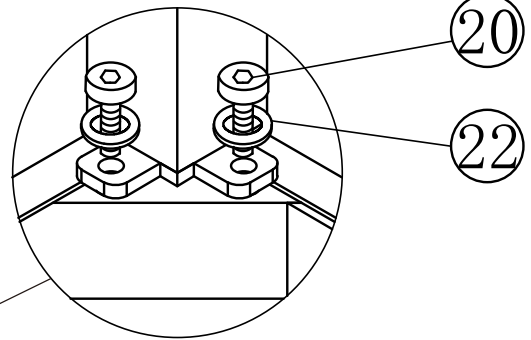
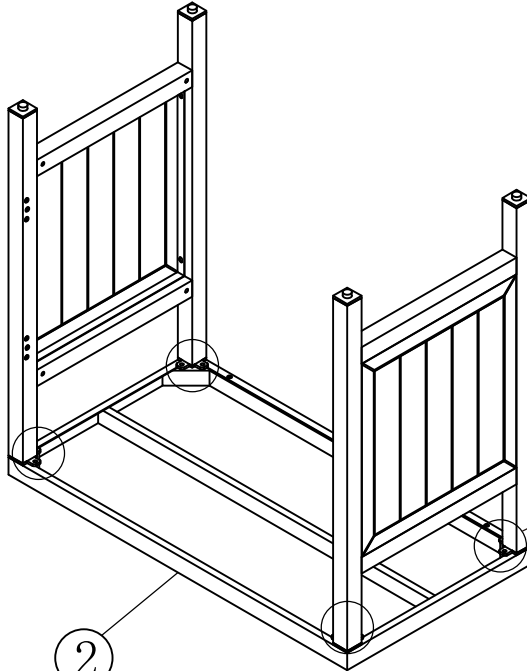

# Step 5

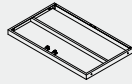

③ 1X  
Aluminum Middle Worktop



M6X15  
⑲ 4X

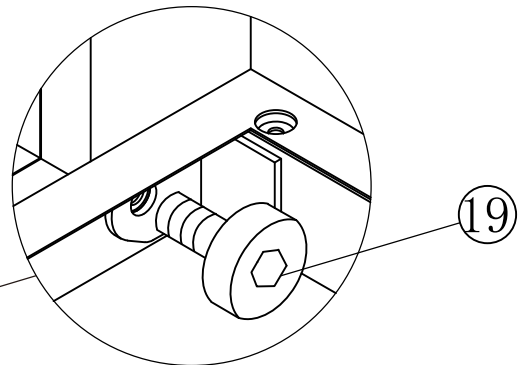
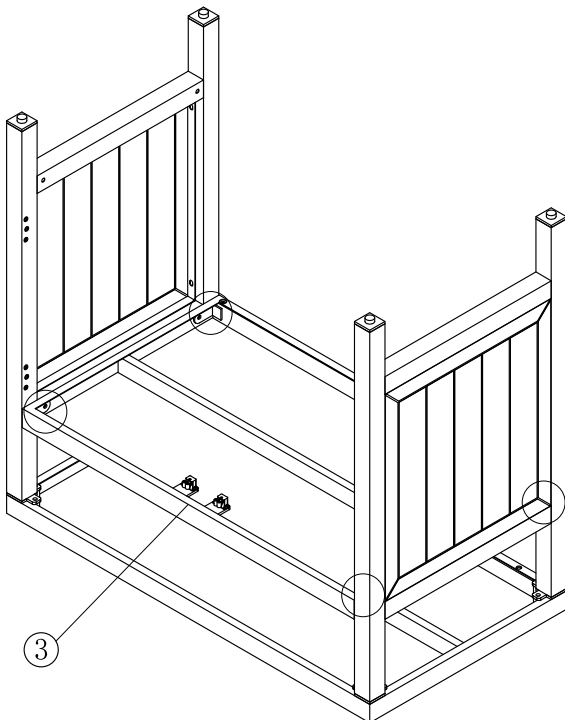

# Step 6

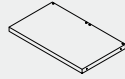

④ 1X

Aluminum Base Plate



M6X15

⑱ 4X

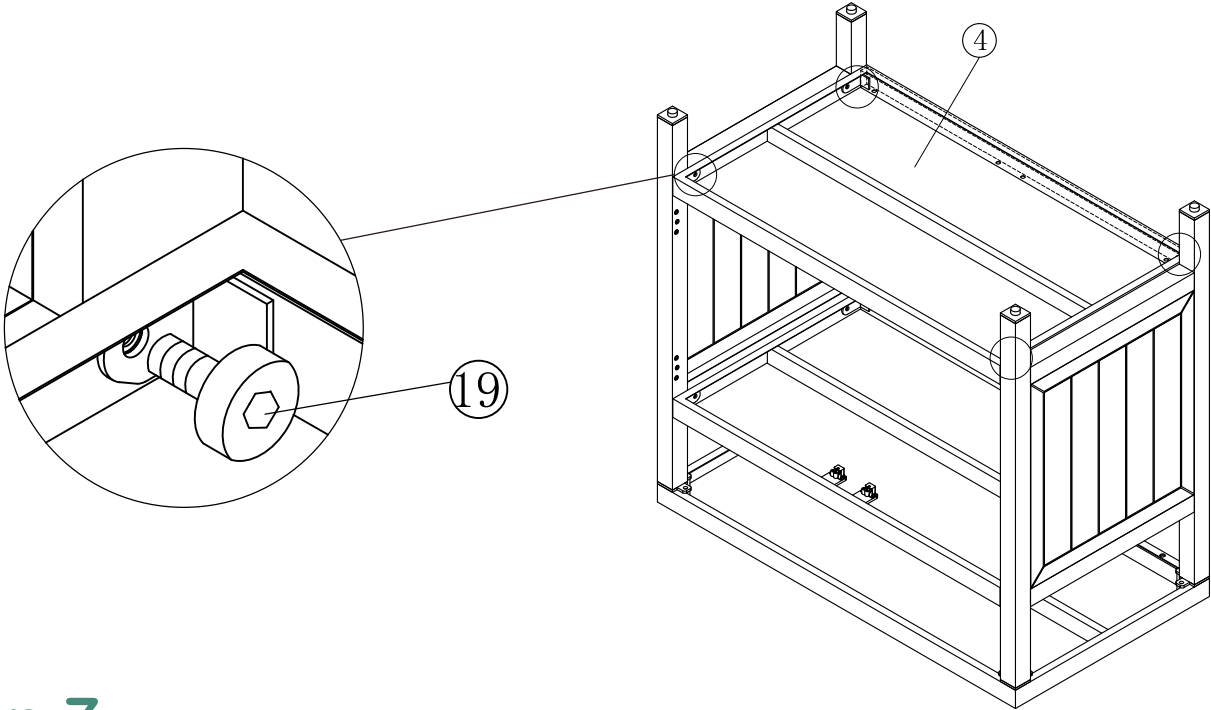

# Step 7



⑫ 2X

Aluminum Backwall



M6X15

⑱ 8X

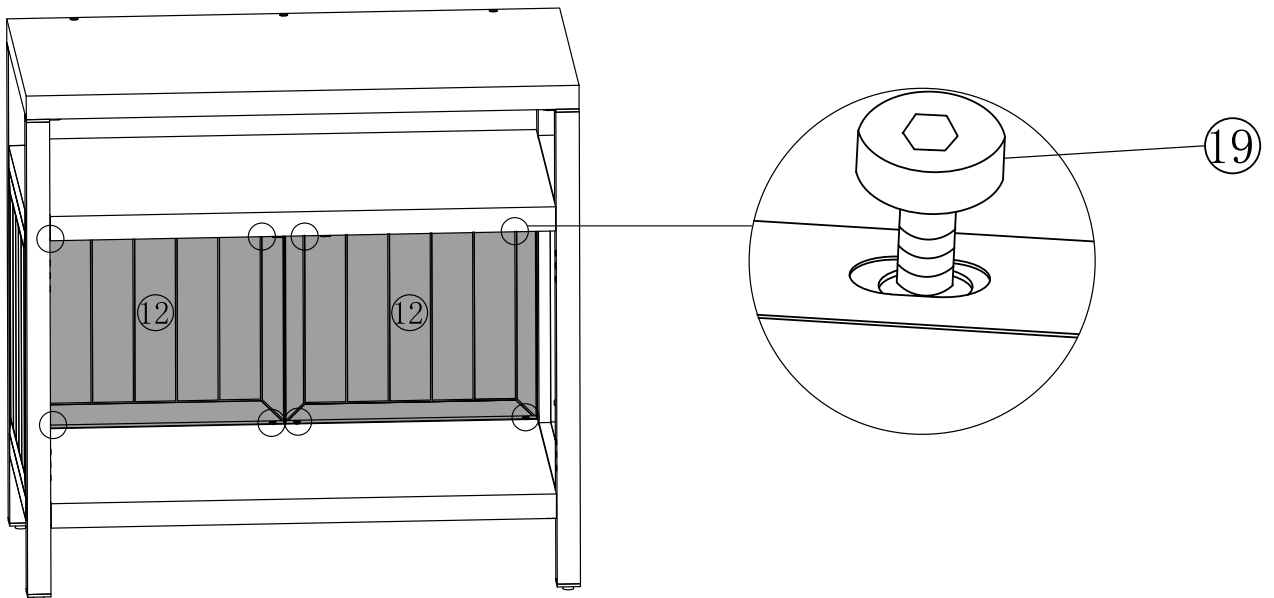

# Step 8



13 1X

Aluminum Left Door



15 1X

Handle

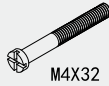

M4X32

16 2X



M4

17 2X



24 1X

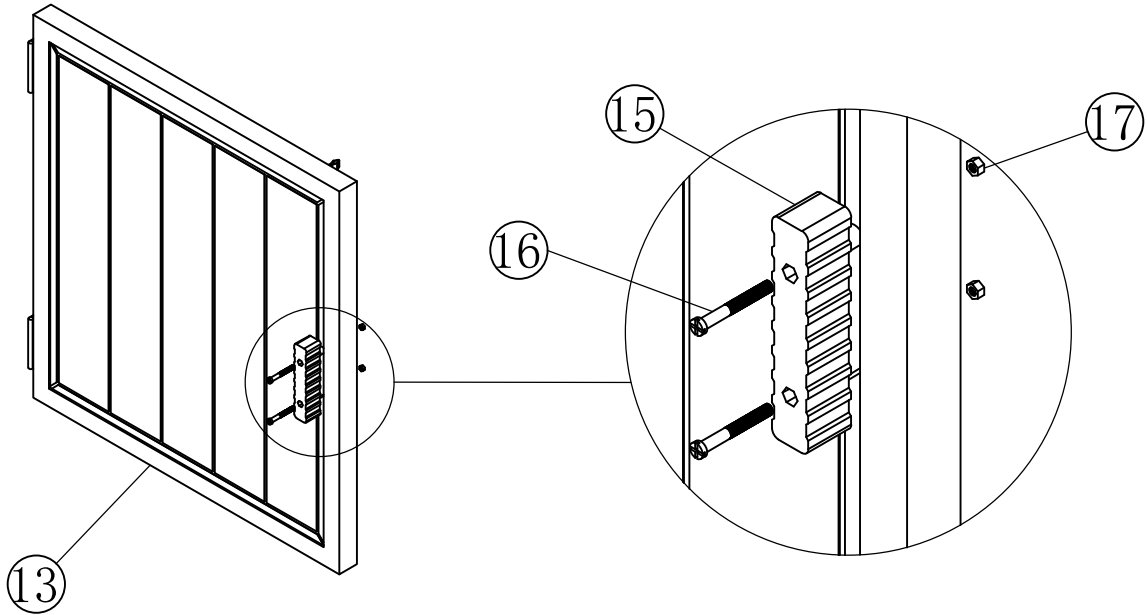

# Step 9



14 1X

Aluminum Right Door



15 1X

Handle

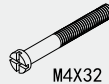

M4X32

16 2X



M4

17 2X

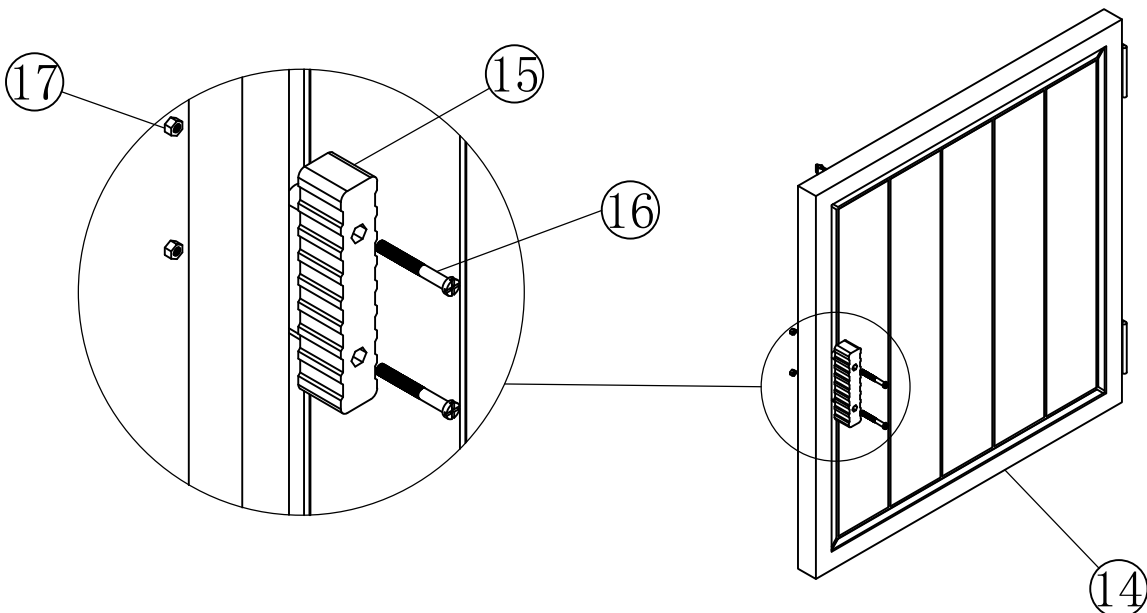



# Step 10



13 1X

Aluminum Left Door



14 1X

Aluminum Right Door



M4\*12  
18 12X

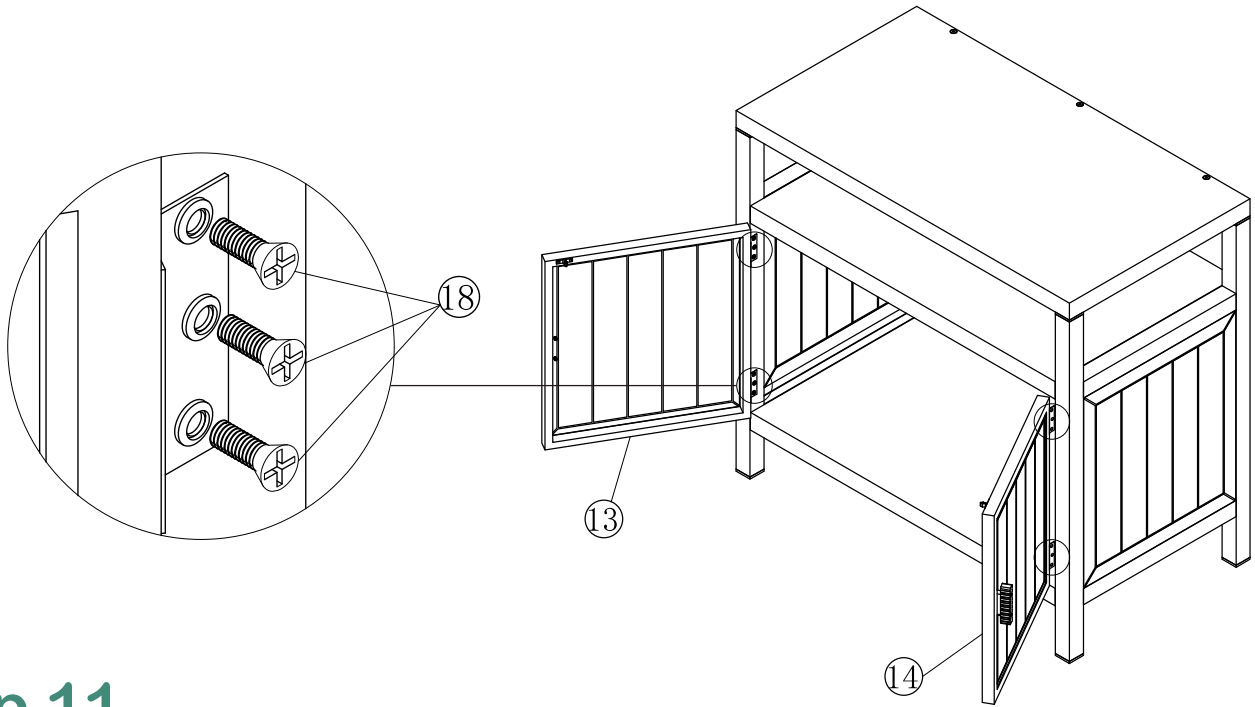

# Step 11



1 1X

Aluminum Side Sheet

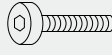

M6X55

21 3X



D6

22 3X

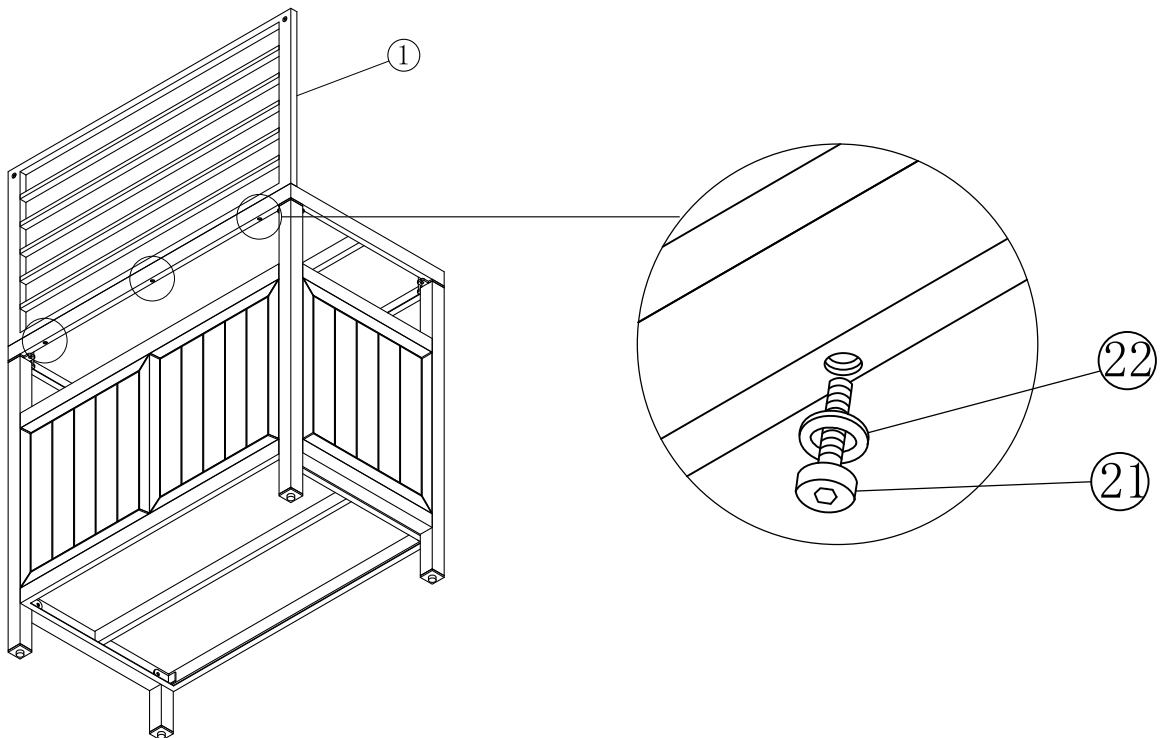

# Step 12

---

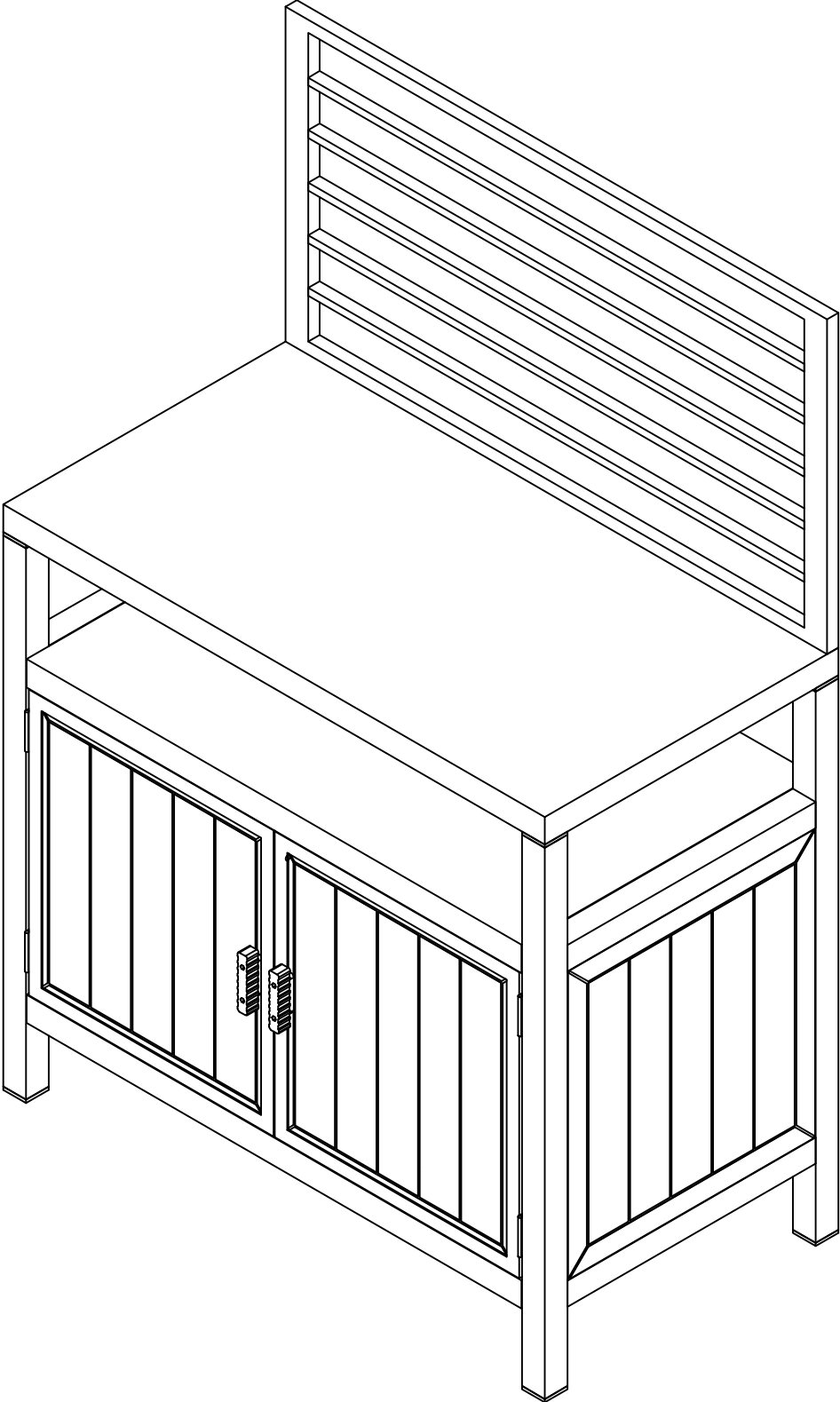

# about the outdoor kitchen series

---

We created the Outdoor Kitchen line because we want everyone to enjoy the outdoors! All outdoor kitchen lines are modular in design, fit together seamlessly and are made of sturdy, durable stainless steel countertops for easy connection. Like all domi outdoor products, the Outdoor Kitchen series has stood the test of time and will become a product that consumers trust.



---

Missing part? Damaged? Contact us via email at [service@domioutdoorliving.com](mailto:service@domioutdoorliving.com)

[www.domioutdoorliving.com](http://www.domioutdoorliving.com)

---

# Series products

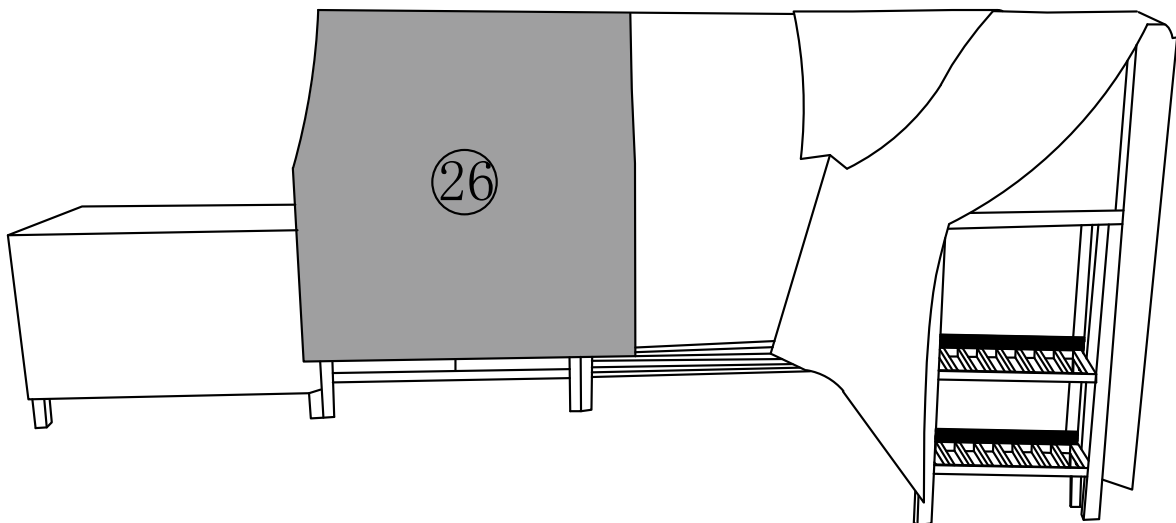
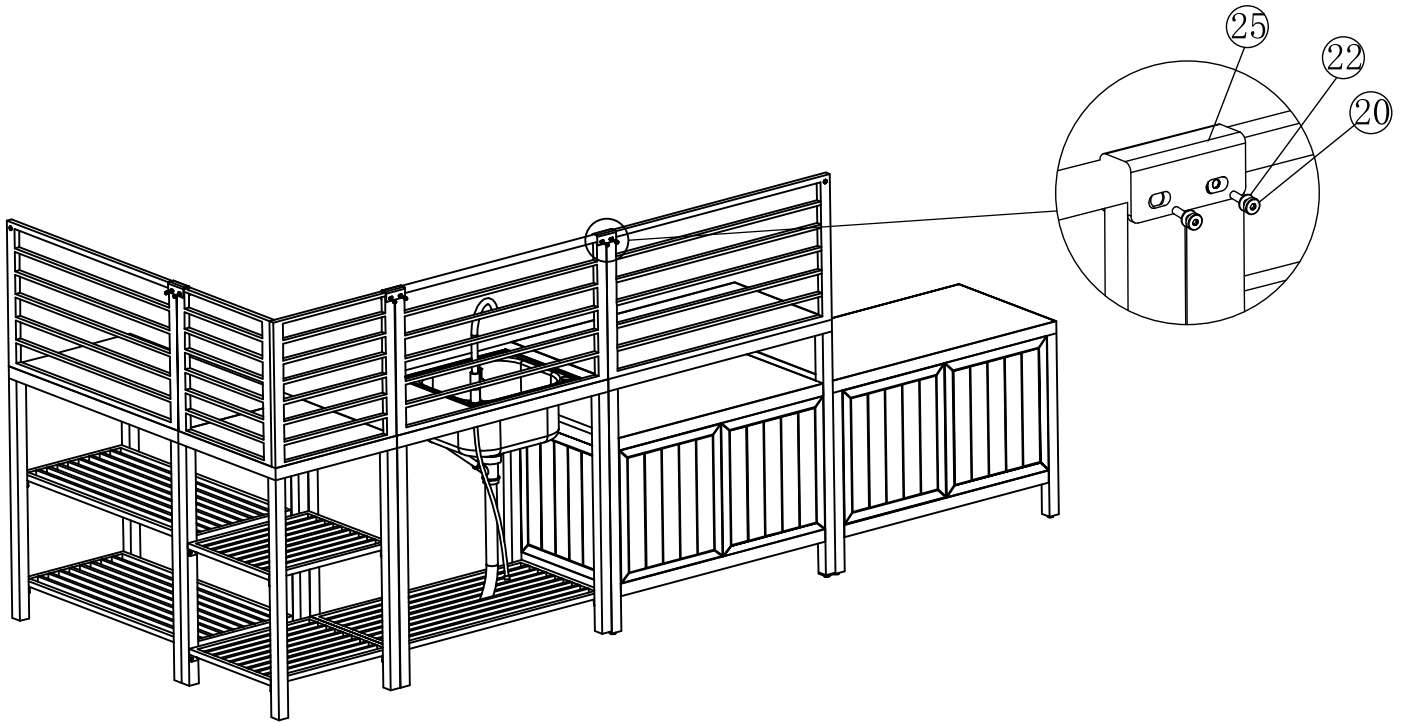
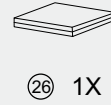

# about the outdoor kitchen series

---

We created the Outdoor Kitchen line because we want everyone to enjoy the outdoors! All outdoor kitchen lines are modular in design, fit together seamlessly and are made of sturdy, durable Aluminum countertops for easy connection. Like all domi outdoor products, the Outdoor Kitchen series has stood the test of time and will become a product that consumers trust.



---

Missing part? Damaged? Contact us via email at [service@domioutdoorliving.com](mailto:service@domioutdoorliving.com)

[www.domioutdoorliving.com](http://www.domioutdoorliving.com)

---