

# PLEASE READ THE INSTRUCTIONS

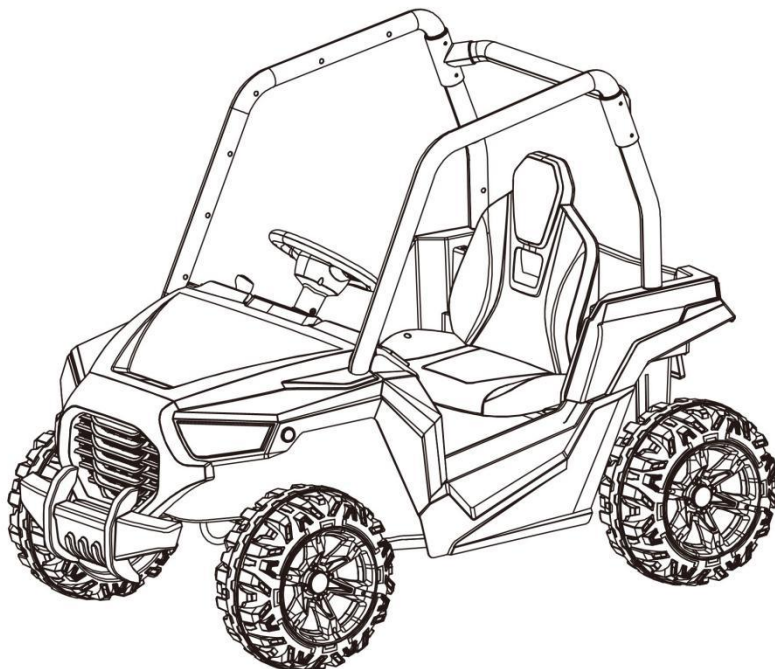

**Styles and colors may vary**

◎ Suitable age for 3-8 Years

◎ Maximum user weight: 30kg

◎ Adult assembly required

# INSTRUCTION MANUAL



Charge for 4-6 hrs  
before initial use.

After initial charge,  
follow the normal  
recommended  
Charging time.



## **SAFETY**

Please retain these instructions for future reference.

**NOTE:**For best performance,only use this vehicle on flat and hard surfaces.

**AGE RANGE:**3 to 8 years old

**WEIGHT CAPACITY:**30KG is the maximum weight for 1 rider(combined)

The following safety hazards may result in serious injury or death:

- This product contains small parts.Keep children away during assembly.Make sure to remove all packaging material and parts from underneath the vehicle body.
- Never open the battery.Batteries contain lead and lead compounds(acids).
- Limbs,hair,and clothing can get caught in moving parts.Always wear shoes,keep limbs away from moving parts,and do not wear loose clothing while operating this vhicle.
- This vehicle does not have brakes or braking capability.Do not leave a child unattended during operation.DO not use this in a location that may require braking capability.as this could result in loss of control,which may cause serious injury or death.
- Use of this vehicle near streets,motor vehicles,steps,bodies of water,sloped surfaces,hills,wet areas,flammable vapors,in alleys,at night,or in the dark could result in an unexpected accident.
- Usu of this vehicle in unsafe conditions such as snow,rain,loose dirt,mud.sand,or gravel may result in an unexpected accident such as tipping over,and could damage the electrical system or battery.
- Do not operate this vehicle in an unsafe manner.Examples include but are not limited to:
  - pulling the vehicle with another vehicle or similar device
  - Allowing more than two children to ride
  - Pushing the user
  - Traveling at an unsafe speed

## BATTERY WARNINGS

The following safety hazards may result in serious injury or death:

- Use of a battery or charger other than the supplied rechargeable battery and charger may cause a fire or explosion. Only use the supplied battery and charger.
- Use of the rechargeable battery and charger for any other product may result in overheating, fire, or explosion. Never use the supplied rechargeable battery and charger with another product.
- Explosive gases are created during charging. Charge the battery in a well-ventilated area. Do not charge the battery near heat or flammable materials.
- Contact between the positive and negative terminals may result in fire or explosion. Avoid direct contact between the terminals. Picking up the battery by the wires or charger can cause damage to the battery and may result in a fire. Always pick up the battery by its case or handles.
- Liquids on the battery may cause fire or electric shock. Always keep all liquids away from the battery and keep the battery dry. Contact or exposure to battery leakage (lead acid) may cause serious injury. If contact or exposure occurs immediately call your physician. If the chemical is on the skin or in the eyes, flush with cool water for 15 minutes. If the chemical was swallowed, immediately give the person water or milk. Do not give water or milk if the patient is vomiting or has a decreased level of alertness. Do not induce vomiting.
- Battery posts, terminals, and related accessories contain lead and lead compounds (acid)
- Tampering or modifying the electric circuit system may cause a shock, fire or explosion and permanently damage the system. Exposed wiring and circuitry in the charger may cause electric shock. Always keep the charger housing closed.

## USER WARNINGS

The following safety hazards may result in serious injury or death:

- Never leave a child unattended.
- Always sit in the seat when using this vehicle.
- Keep your hands, hair, and clothes away from moving parts.
- Always wear shoes when operating this vehicle.
- Maximum of two children are allowed in the vehicle at a time.
- Children under 3 years of age cannot use the vehicle.
- Only drive on level ground.
- Do not go near swimming pools or other bodies of water, drop-offs, or up and down steep inclines.
- Do not drive the vehicle into loose dirt, mud, sand, fine gravel, or on wet surfaces.
- Do not drive the vehicle on streets or near cars.

## SPECIFICATIONS

Item	Specification
Batteries	12V
Motor	12V
Age	3-8years
Max Weight	30KG
Dimension	115*69*86.5CM
Speed	2.5-4.5 km/hr
Play Time	1-2 hours / recharger time 8-12hours
Charger	Output DC 12V

## TOOLS REQUIRED

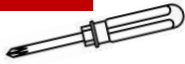

SCREWDRIVER  
(BRING YOUR OWN)



M10 WRENCH  
(PROVIDED)



2 PERSON  
ASSEMBLY



APPROXIMATELY  
45 MIN.  
ASSEMBLY

## HARDWARE

1

M4\*12mm  
SCREW



7 PCS

2

φ 12 WASHER



6 PCS

3

M10 NUTS



4 PCS

4

M5\*40mm  
SCREW



4 PCS

5

M5 NUTS



5 PCS

6

7

8

## PARTS

A

FRONT BAFFLE



2 PCS

B

REAR BAFFLE



2 PCS

C

WHEEL COVER

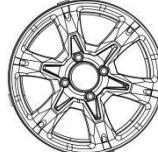

4 PCS

D

STEERING WHEEL



4 PCS

E

FRONT BUMPER



1 PCS

F

GEAR BOX (L/R)

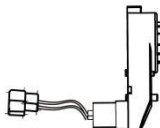

2 PCS

G

TRAILER DIVIDER

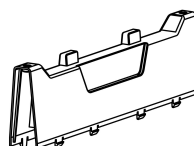

1 PCS

H

TRAILER PLATE

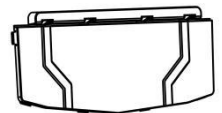

1 PCS

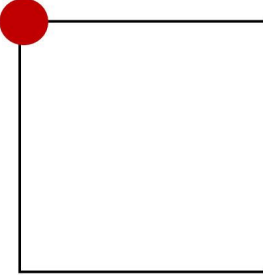
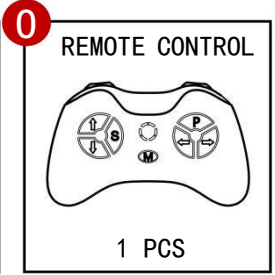
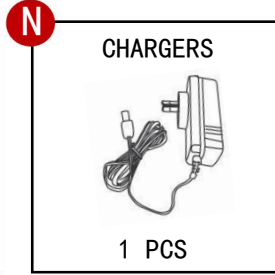
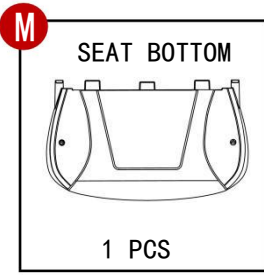
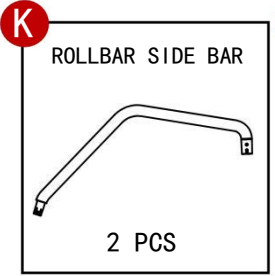
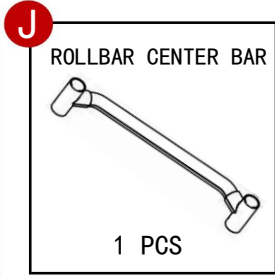
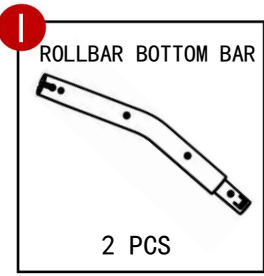

**PRODUCT ASSEMBLY**

Insert the front bumper into the car

Put the gasket, front wheel, gasket and nut into the front axle in turn.

Fix The nut with the M10 wrench and then attach the wheel cover to the wheel

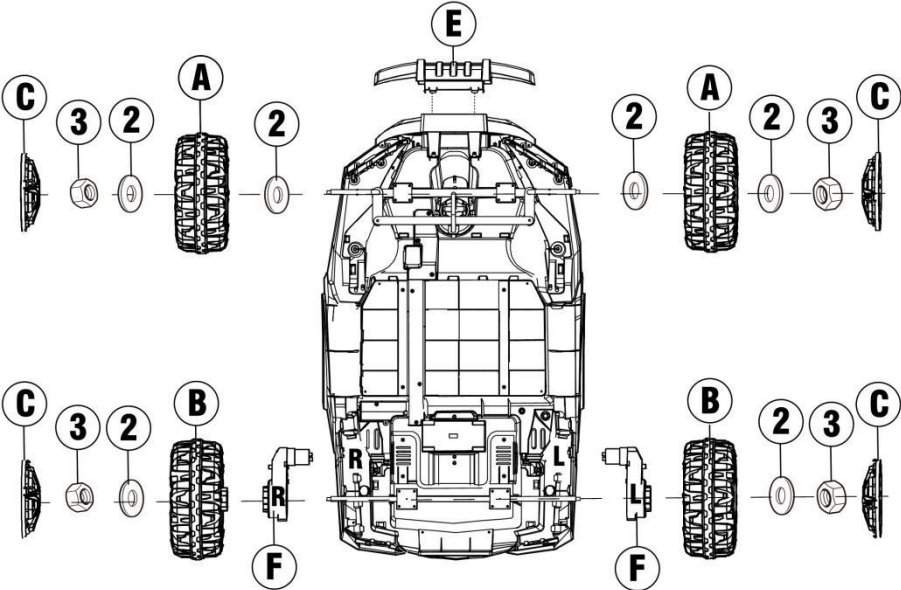

Place the gear box, rear wheel, Washer, and nut on the rear axle in turn.

Fix The nut with the M10 wrench and then attach the wheel cover to the wheel.

## PRODUCT ASSEMBLY

Follow the assembly steps in the order listed below.

- D** Attach the steering wheel.
- Remove the nut and bolt from the steering wheel.
  - Connect the wires coming from the steering column to the wires on the steering wheel.
  - Insert the steering wheel over the steering and secure with nut and bolt.

- H** Attach the trailer cover.
- Insert the tabs on the trailer plate into the slots on the UTV body.

- G** Attach the trailer divider.
- Insert the trailer divider over the brackets on each side of the UTV body.
  - Fasten with two small screws.

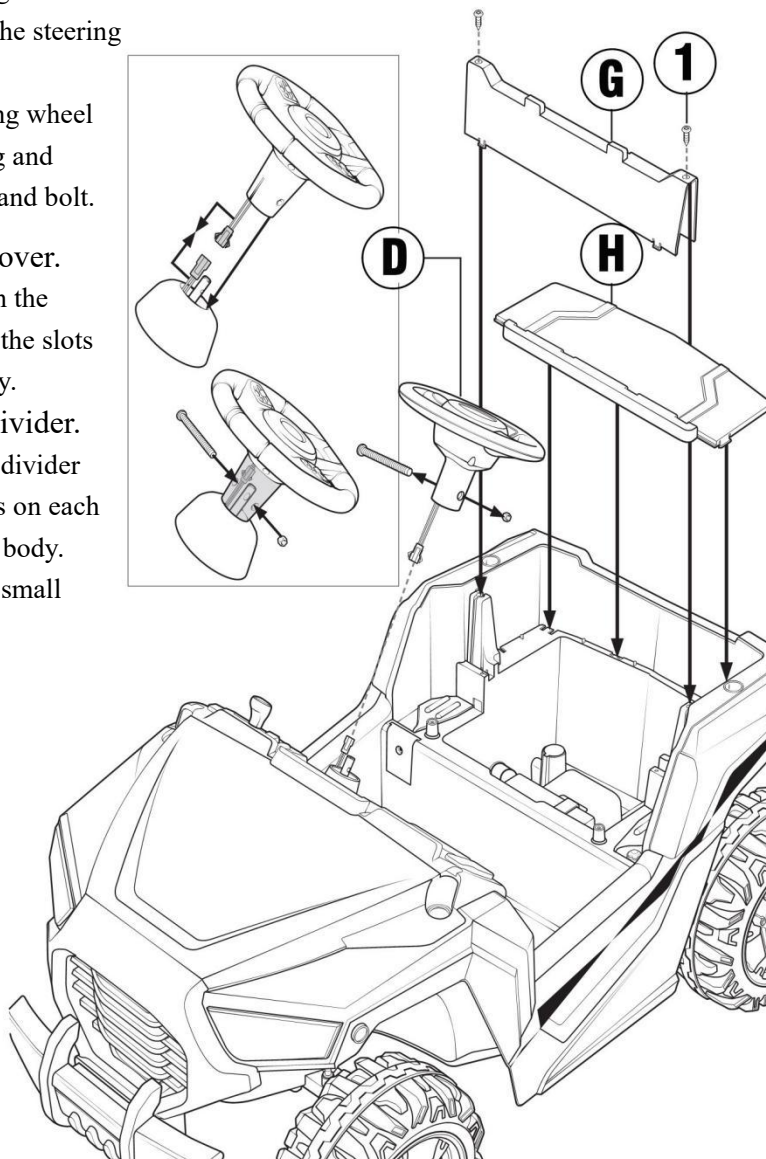



## PRODUCT ASSEMBLY

Follow the assembly steps in the order listed below.

Attach the battery wire connectors.

- Find the main power wires and insert the plug-in of the wires into the slot of the receiver.
- Connect the white connectors coming from the gear box to the white wire connector coming from the battery.

**L** **M** Attach the seat.

- Insert the tabs on the back of the seat into the slots on the back of the battery compartment.
- Place the seat assembly over the battery compartment.
- Fasten the seat back to the UTV with two small screws.
- Fasten the seat bottom to the UTV with two small screws.

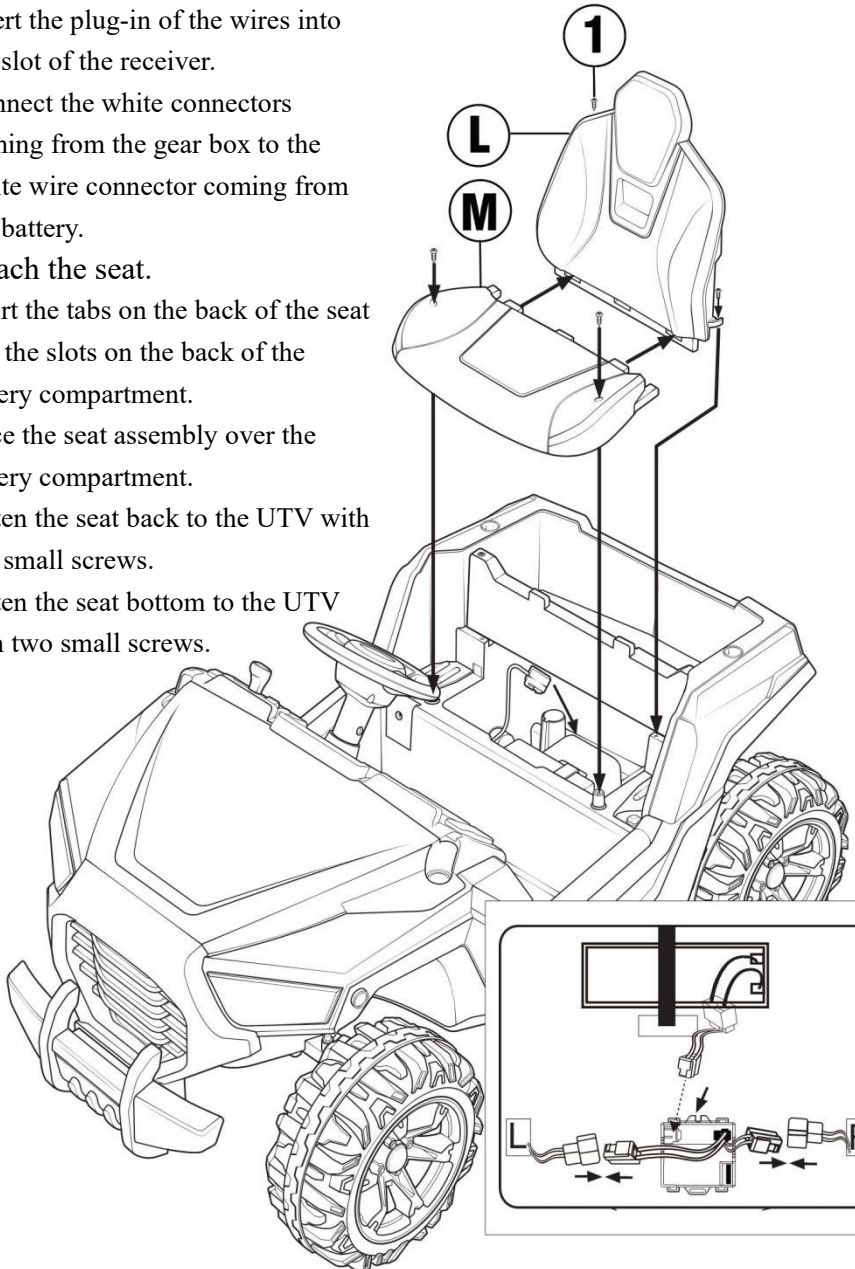

## PRODUCT ASSEMBLY

Follow the assembly steps in the order listed below.

Assemble the rollbar.

- Insert the sidebars into the top of each center bar openings.
- Insert the bottom bars up into the bottom center openings.
- Ensure the holes of in the center bar and bottom bars are completely aligned.
- Fasten with the four bolts and nuts.

Attach the rollbar assembly.

- Insert the bar ends into the rollbar slots.
- Press each bar down firmly into place.

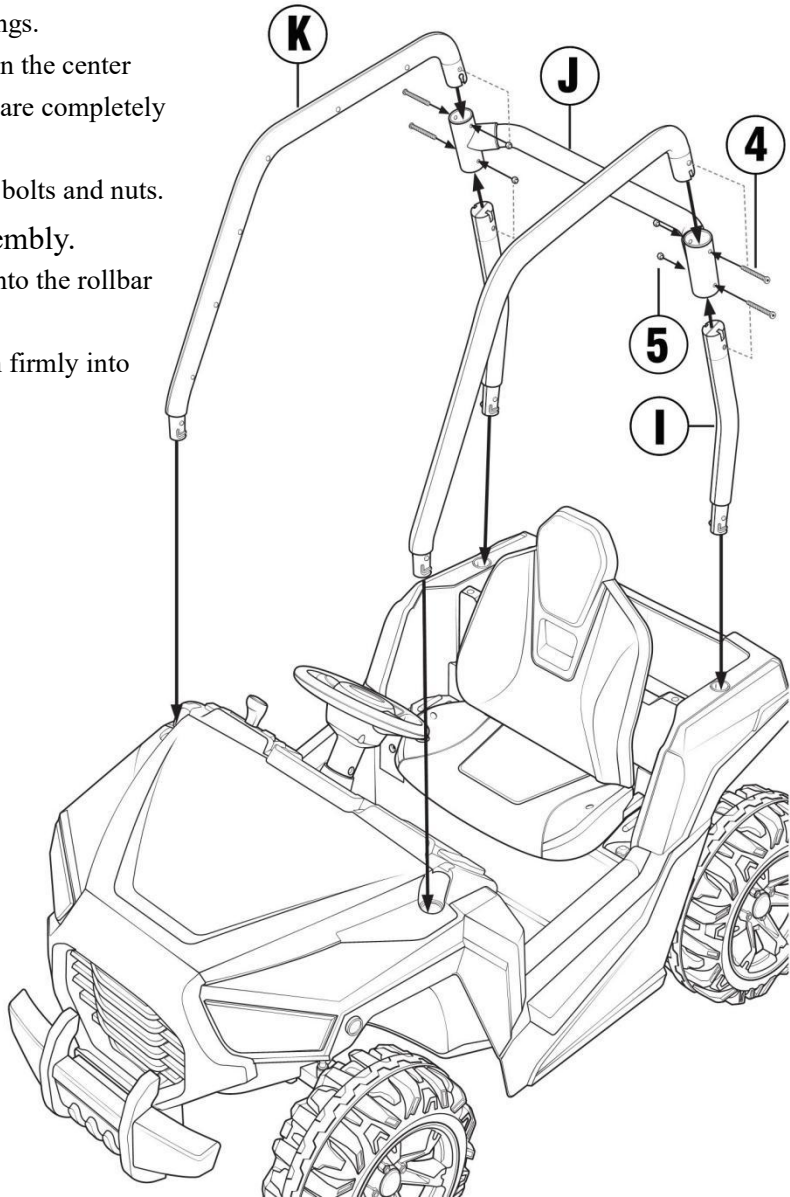

## DASHBOARD DIAGRAM

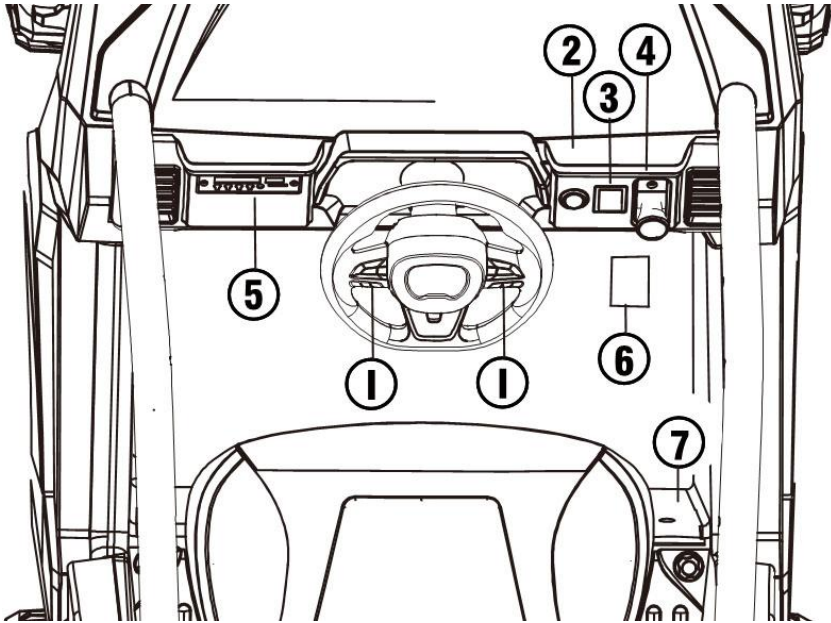

1. Horn button; press it to play the horn sound;
2. Power button: turn the car on or off;
3. High and low speed buttons: press it to switch the vehicle high-speed function/low-speed function;
4. Forward/backward switch: control the moving direction of the car, forward or backward; the middle gear is stop;
5. Car central control panel;
6. Foot switch: Depress the switch, the vehicle moves; lift the foot to release the switch, the vehicle will brake slowly;
7. Charging hole: connect the charger to charge the vehicle (please read the charging instructions carefully before charging)

## DASHBOARD DIAGRAM

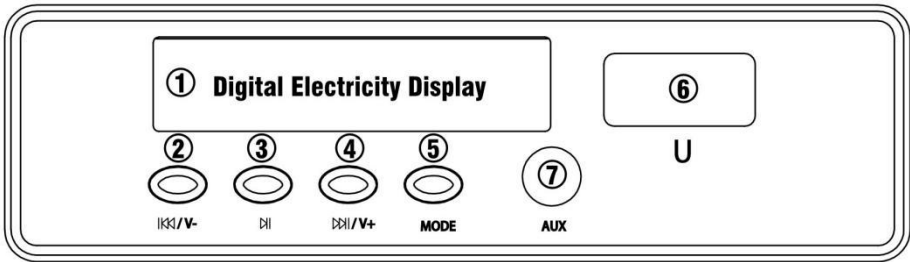

1. Voltage display lamp: You can judge whether the battery needs to be charged by displaying the number of lamps. The smaller the number of lamps, the lower the voltage; please charge in time;
2. Previous song/volume-: switch to previous song or radio channel/long press: decrease volume;
3. Radio function: turn on/off the radio;
4. Next song/volume+: switch to next song or radio channel/long press: increase volume;
5. MODE: Mode switching Music/Radio/Wireless Technology;
6. U;
7. MP3 interface: connect with other devices and play audio through the data cable;

## REMOTE CONTROL DIAGRAM

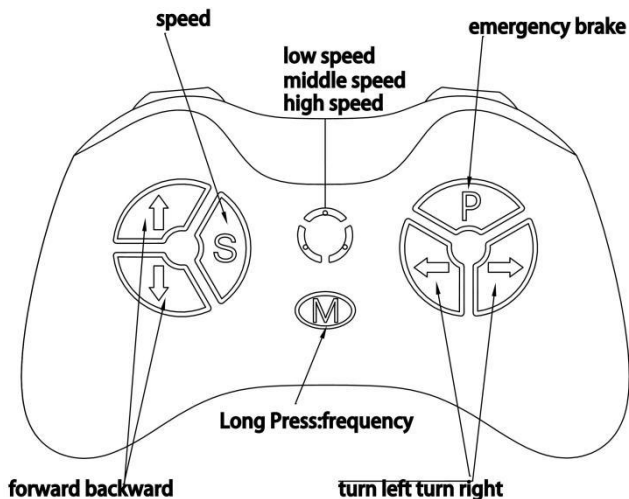

### Warning

Only used by adults

**Remote control first. When the remote control is on, foot pedal is not workable**

#### Operation Manual:

Take out the remote control, Open the battery compartment on the back of the remote control and add two AAA LRO3 alkaline batteries. Pay attention to the polarity of the batteries. When the alignment light and speed indicator light up, it indicates that the battery installed is correct. This product does not provide dry batteries.

#### <Button Description >

(1) Long press on the frequency key(M) 2-4 seconds, Low speed LED light flashing. Turn on the power of the car, Low speed LED light keep flashing to long lighting, then frequency bind succeed. If the frequency bind failed (Low speed LED light flashing) , remove the battery and repeat steps

P: Press to brake。

S: Speed: press to change speed(low,middle and high speed).

△Forward ▽backward。

◁ Turn left ▷ turn right

## REMOTE CONTROL DIAGRAM

- 2) Brake button: Press it to stop moving; press it again to move.
- 3) Speed selection key and speed indication: used to select speed of the car. Press the key once to switch the speed once. 3 speeds are cyclically switched, and the switching sequence is: low-medium-high. The speed indicator is arranged from top to bottom on the remote control: high-speed lamp, medium-speed lamp, low-speed lamp; when switching to one speed, the corresponding indicator lamp will light up. Note: The speed grade changes only when moving forward
- 4) Forward/backward keys: used for forward and backward movement control. When one of the keys is pressed, the moving speed will slowly increase to reach the set speed level. Therefore, children will not have a sudden impact.
- 5) Left turn/right turn key: used for left and right direction control.

**Note:** without operation after 10 seconds, indication light will off into power saving mode

## CHARGING INSTRUCTIONS

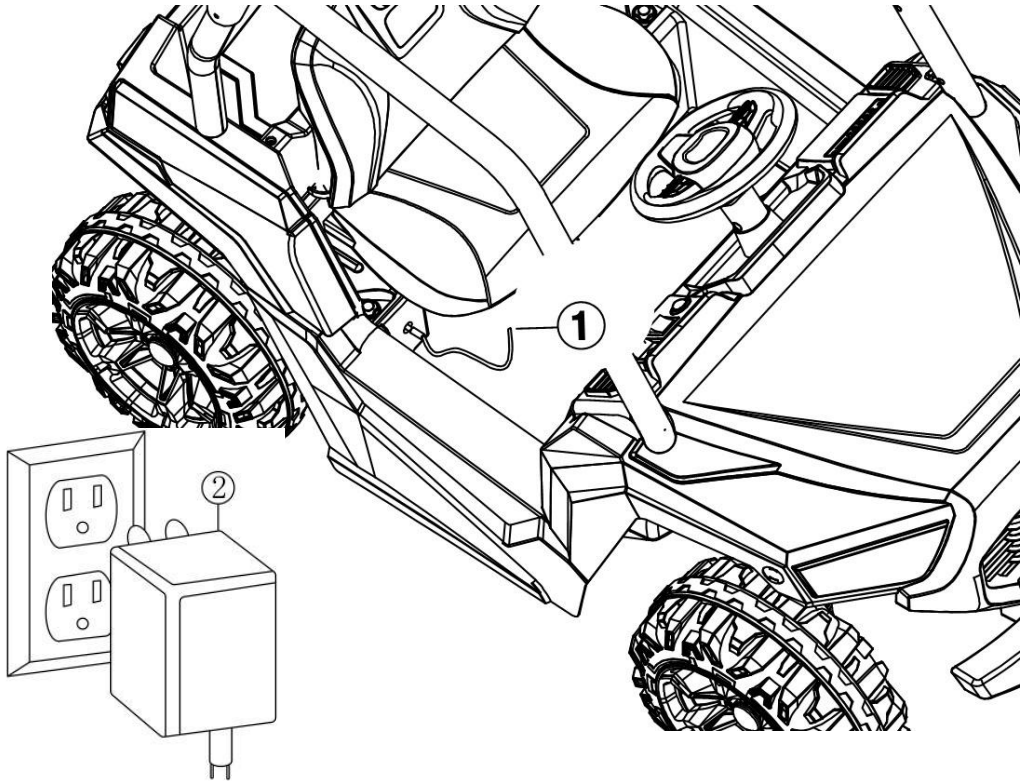

1. Insert the charger jack into the charging hole of the car.
2. Plug the charger plug into the stable matching AC power supply as shown in the picture.

- Charge the battery 15 to 18 hours before initial use.
- On average, you will need to charge the battery between 8 and 12 hours. Do not charge the battery for more than 20 hours. Failure to charge the battery as directed could cause permanent damage to the battery and void the warranty.
- Damage to the battery may occur if it is allowed to drain completely. Do not allow the battery to drain completely.
- Check the battery and charger (supply cord, connector) for wear and damage before charging. DO not charge the battery if damage has occurred.
- Only an adult who has read and understood the safety warnings should handle, charge and recharge the battery.

## CARING FOR YOUR RIDE-ON

- Park the vehicle indoors or cover it with a tarp to protect it from wet weather.
- Do not leave the vehicle in the sun for long periods of time or fading may occur.  
Store in shade or cover with tarp.
- Do not wash the vehicle with a hose.
- Do not wash the vehicle with soap.
- Charge battery at least once a month to prolong the life of the battery.

## TROUBLESHOOTING

PROBLEM	REASON	SOLUTION
Vehicle does not move	Low battery	Fully charge the battery
	Electrical protection	Stop use for several minutes and restart
	Switch not in the correct position	Completely press in switches
	Battery connectors disconnected	Plug in battery connectors
Battery does not recharge	Battery connectors disconnected	Plug in battery connectors
	Charge not connected to socket or outlet	Completely plug in the charger
Battery does not last	Battery does not have a full charge	Fully charge the battery
Battery is warm and makes a slight noise while charging	Normal	Normal
Slow speed	Low battery	Fully charge the battery
	Overloaded vehicle	Reduce the weight on the vehicle
	Uneven or sloped road	Drive on flat pavement
Vehicles shakes while driving	Loose connection to motor	Ensure the motor is properly connected to the battery
Difficulty shifting between forward/reverse	Attempting to shift while vehicle in motion	Only shift when the vehicle is at a stop
Forward and reverse switch is flipped	Gear boxes are installed incorrectly	Make sure the L gear box is on the left and R gear box is on the right



## WARNINGS REGARDING BATTERIES

The battery on the vehicle is not replaceable.

- DO not mix old and new batteries.  
DO not mix alkaline, standard (carbon-zinc), or rechargeable batteries.
- Non-rechargeable batteries should not be charged.
- Rechargeable batteries should be charged under adult supervision only.
- Exhausted batteries should be removed.
- The supply terminals should not be short-circuited.
- Do not put batteries next to or in a heat source (fire, electronic heating device, etc.)
- Do not hit batteries against hard objects.
- Do not submerge batteries in water.
- Batteries should be inserted with the correct polarity.

### WARNING:

- Protective equipment should be worn. Not to be used in traffic.
- The toy should be used with caution since skill is required to avoid falls or collisions causing injury to the user or third parties.
- To reduce the risk of injury, adult supervision is required. Never use in roadways, near motor vehicles, on or near steep inclines or steps, swimming pools or other bodies of water; always wear shoes, and never allow more than one rider.

### IMPORTANT

- Always charge battery for a FULL 18hrs the first time you use it.
- Always charge battery for a FULL 10hrs after each use.
- Charge the battery once a month, even if you are not using your vehicle.

 **WARNING:** CHOKING HAZARD-Small parts.  
Not for children under 3yrs.

To reduce the risk of injury, adult supervision is required. Never use in roadways, near motor vehicles, on or near steep inclines or steps, swimming pools or other bodies of water; always wear shoes, and never allow more than one rider

 **WARNING:** ADULT ASSEMBLY REQUIRED

 **WARNING:** Not to be used in traffic

## FCC Statement

### Caution:

This device complies with Part 15 of the FCC Rules. Operation is subject to the following two conditions: (1) this device may not cause harmful interference. (2) this device must accept any interference received, including interference that may cause undesired operation.

Changes or modifications not expressly approved by the party responsible for compliance could void the user's authority to operate the equipment.

This equipment has been tested and found to comply with the limits for a Class B digital device, pursuant to part 15 of the FCC Rules. These limits are designed to provide reasonable protection against harmful interference in a residential installation. This equipment generates uses and can radiate radio frequency energy and, if not installed and used in accordance with the instructions, may cause harmful interference to radio communications. However, there is no guarantee that interference will not occur in a particular installation. If this equipment does cause harmful interference to radio or television reception, which can be determined by turning the equipment off and on, the user is encouraged to try to correct the interference by one or more of the following measures:

- Reorient or relocate the receiving antenna.
- Increase the separation between the equipment and receiver.
- Connect the equipment into an outlet on a circuit different from that to which the receiver is connected.
- Consult the dealer or an experienced radio/TV technician for help.