









Assembly Instruction for COFFEE TABLE CXY2405-01-02-03

No.	DESCRIPTION	SKETCH	Q'TY
1	TOP		1PC
2	BOTTOM PANEL		1PC
3	LEFT LEG		1PC
4	RIGHT LEG		1PC

HARDWARE LIST				
NO.	Name	Sketch	Specification	Quantity
A	BOLT		Ø5/16" x 38mm	8PCS
B	SPRING WASHER		Ø5/16"	8PCS
C	FLAT WASHER		Ø5/16"x19mm	8PCS
D	ALLEN KEY		M5	1PC

NOTES : Do not fully tighten any bolts until last step.

STEP : 1

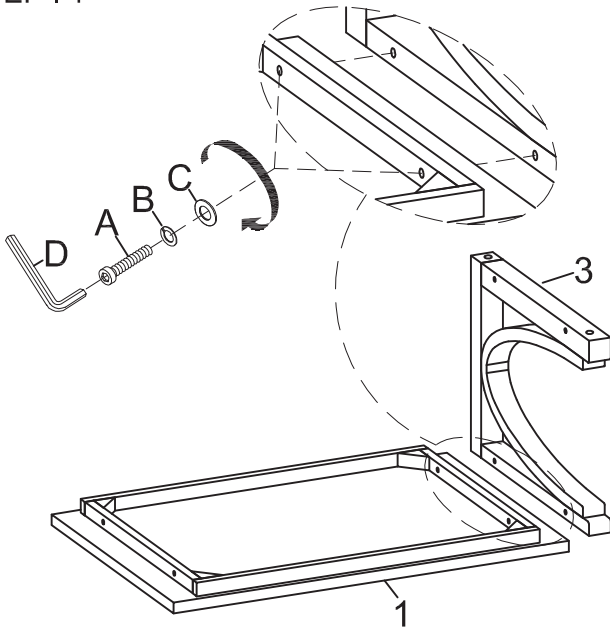

STEP : 2

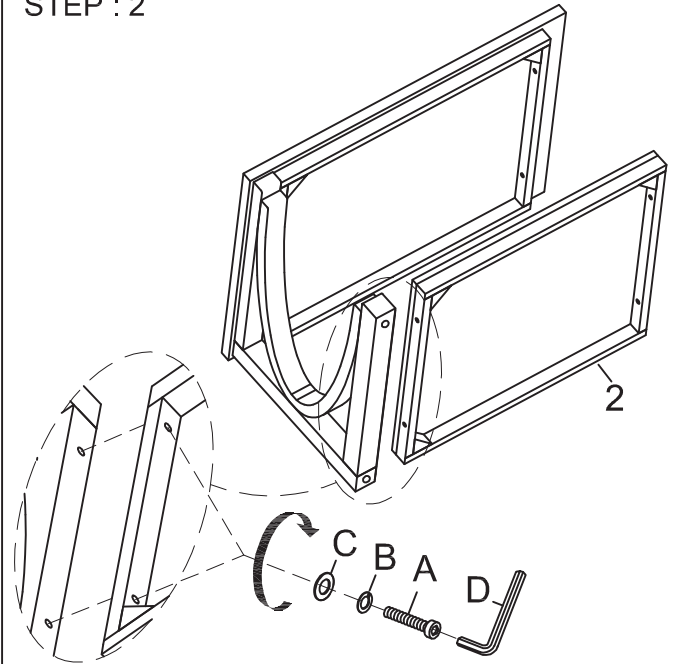

STEP : 3

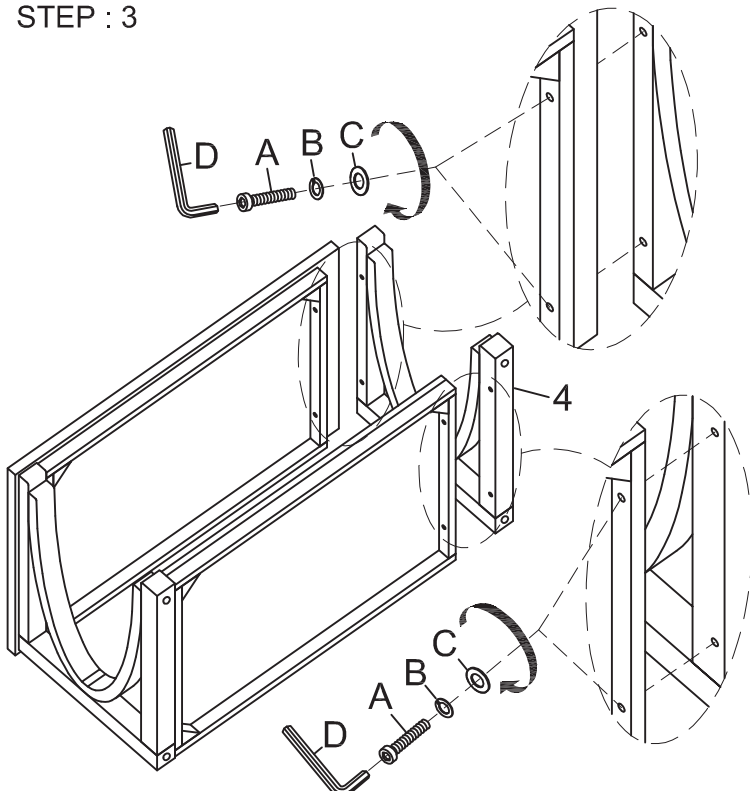

COMPLETED

