

WARNING!

Children have died from furniture tipover. Fixed wall device have been included with this product;you must install the fixed wall device according to these instructions in order to minimize the risk of furniture.If you have any questions about this product or the Fixed wall device , please contact us immediately.

Never allow children to climb or hang on furniture,including drawers or cabiner doors.

In addition to installing the restrains,to help prevent tip-over.

1. Never put a TV or other heavy objects on top of this product.
2. Do not stand on the product.

! WARNING	
	Children have died from furniture tipover. To reduce the risk of furniture tipover: <ul style="list-style-type: none">• ALWAYS install tipover restraint provided.• NEVER put a TV on this product.• NEVER allow children to stand, climb or hang on drawers, doors, or shelves.• NEVER open more than one drawer at a time.• Place heaviest items in the lowest drawers.• Do not defeat or remove the drawer interlock system. <p><i>This is a permanent label. Do not remove!</i></p>
	

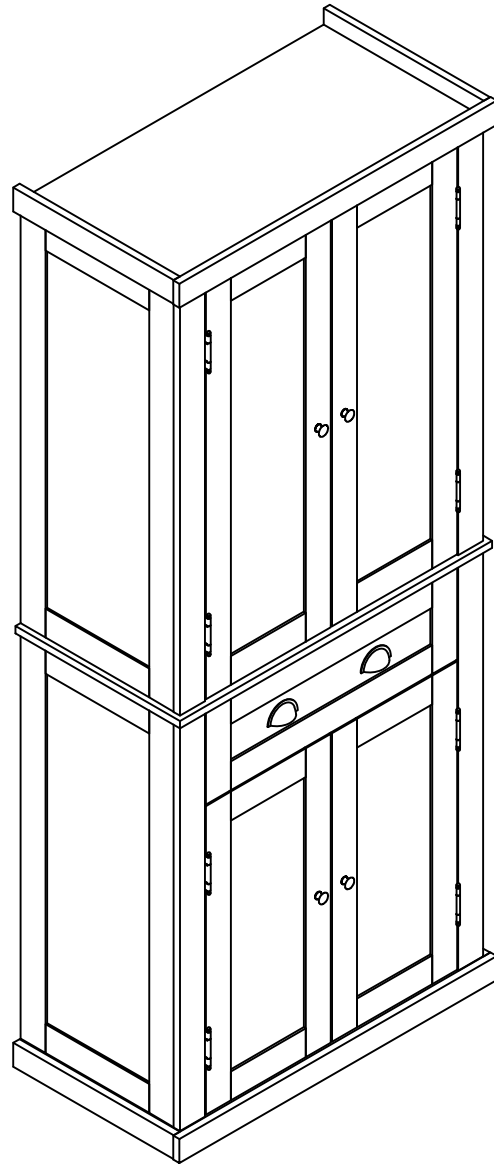

1

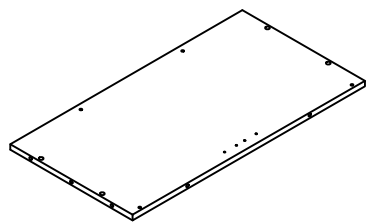

730*385 2PS

2

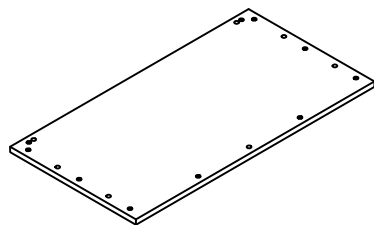

750*395 1PS

3

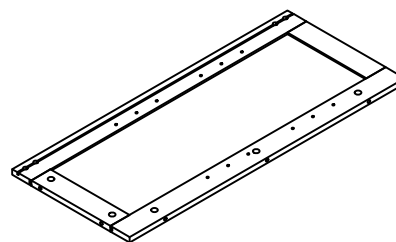

865*369 1PS

4

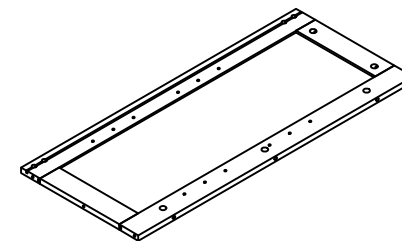

865*369 1PS

5

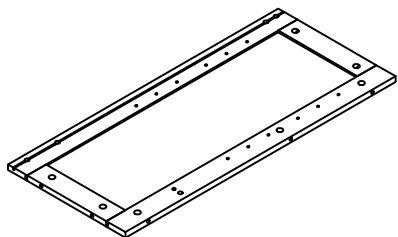

849*369 1PS

6

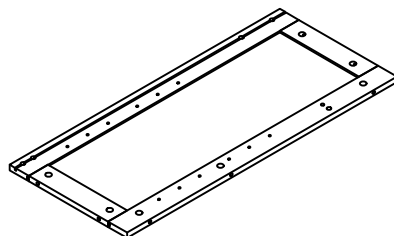

849*369 1PS

7

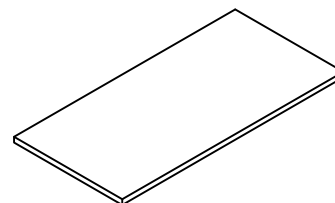

695*340 4PS

8

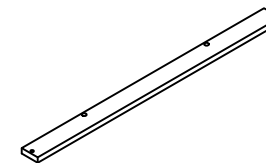

762*50 2PS

9

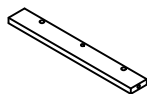

385*50 2PS

10

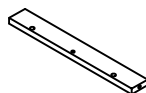

385*50 2PS

11

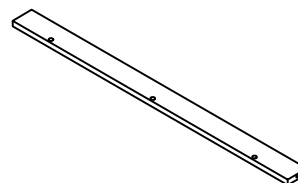

865*60 1PS

12

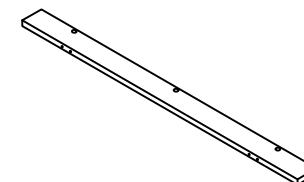

865*60 1PS

13

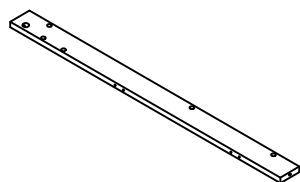

849*60 1PS

14

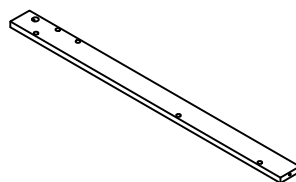

849*60 1PS

15

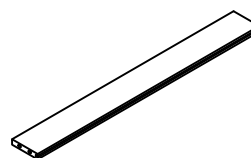

696*80 3PS

16

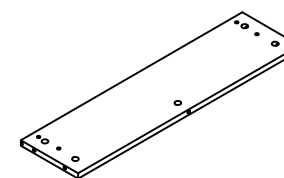

696*180 1PS

17

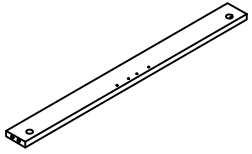

696*60 1PS

18

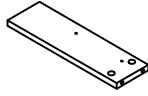

343*100 1PS

19

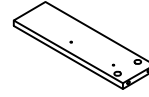

343*100 1PS

20

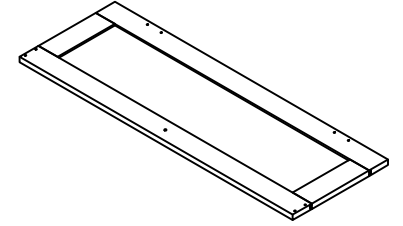

859*300 2PS

21

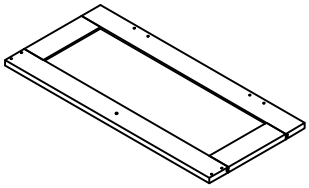

642*300 2PS

22

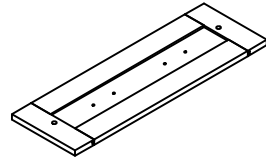

603*198 1PS

23

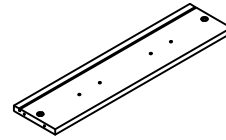

553*130 1PS

24

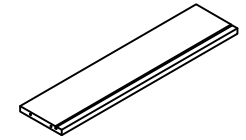

553*130 1PS

25

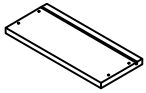

300*130 1PS

26

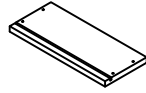

300*130 1PS

27

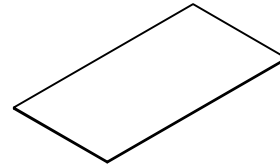

563*278 1PS

28

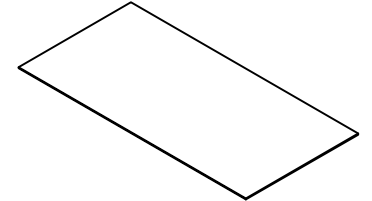

715*352 2PS

29

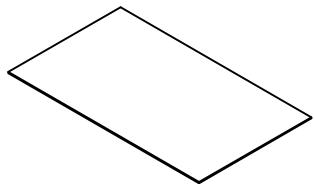

599*352 2PS



Hardware installation demonstration

NOTE: Please make sure "A" hardware tightened and can't be pulled out!

I

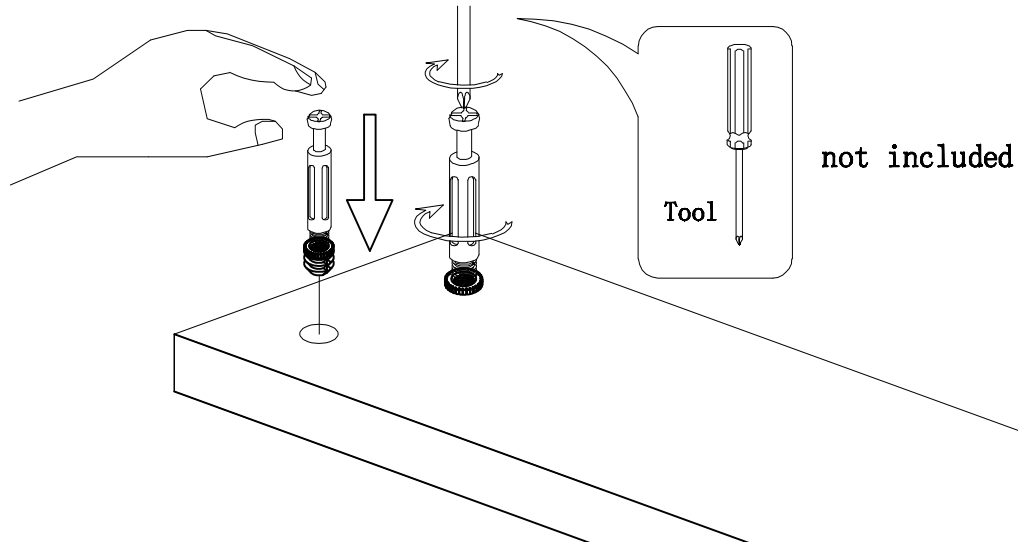

II

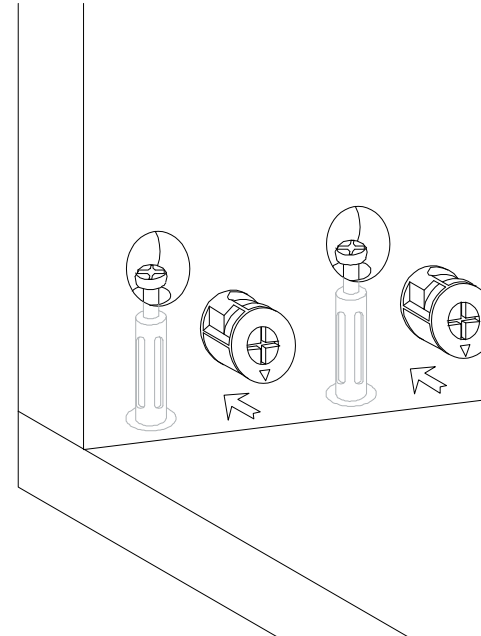

III

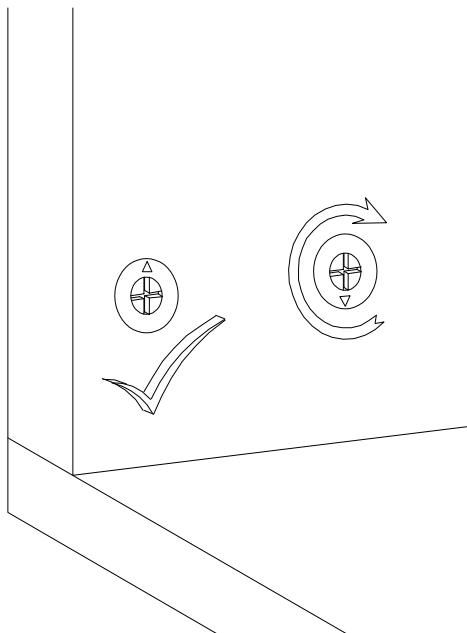





IV

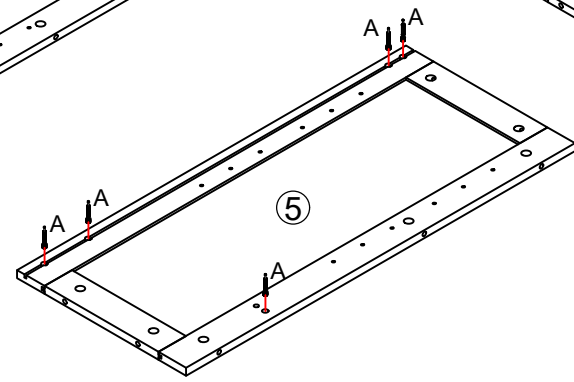
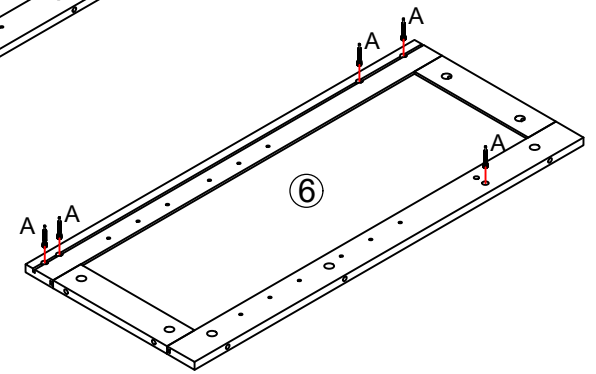
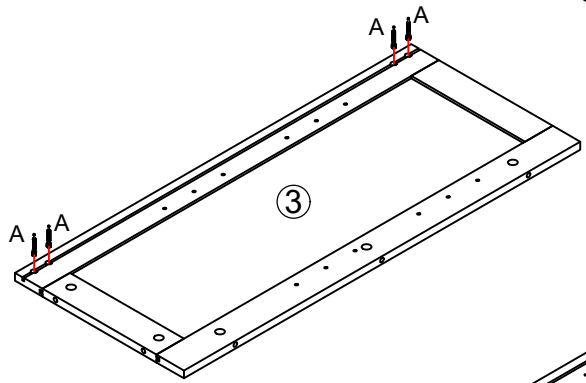
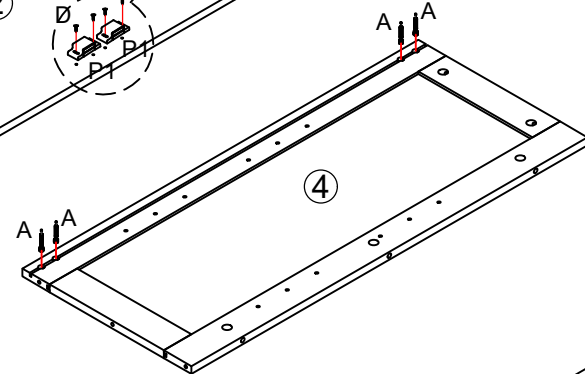
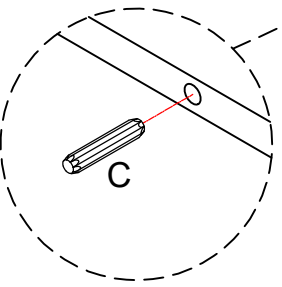
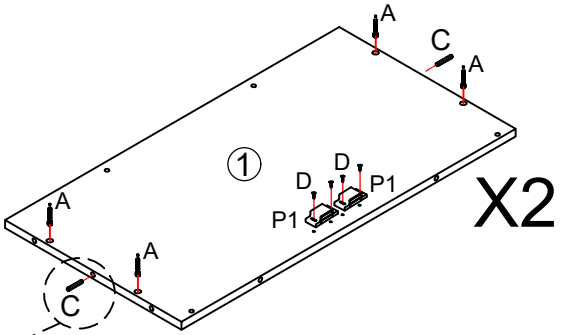
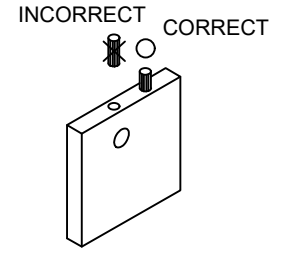
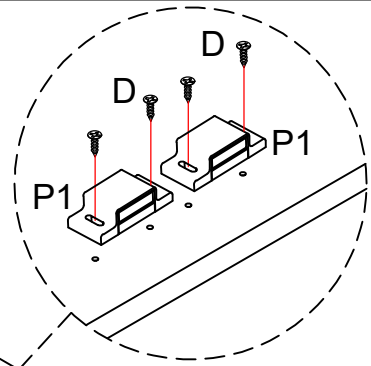
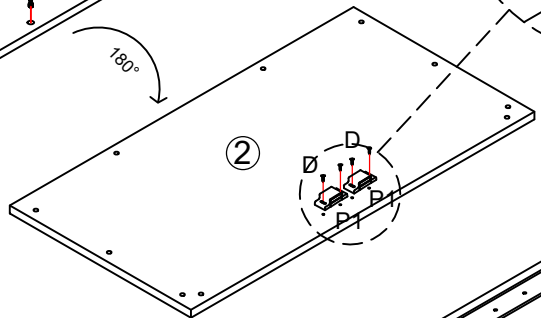
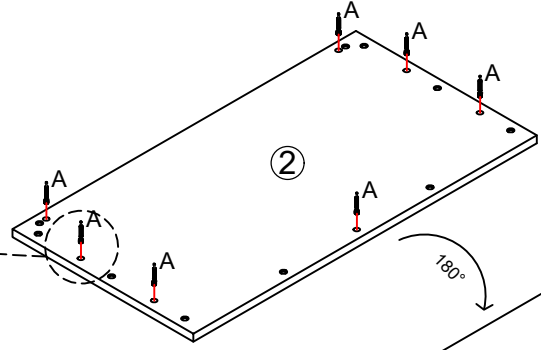
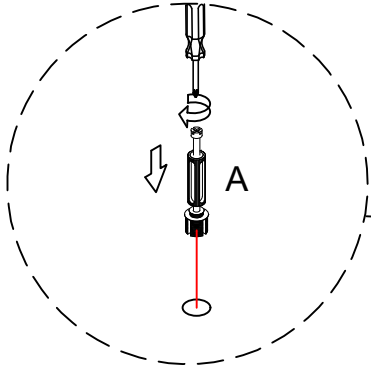

Scan QR code for assembly video

1

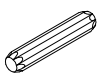



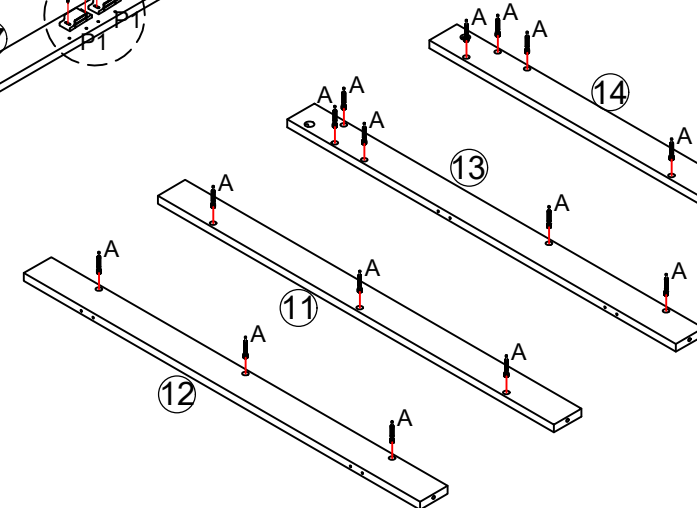
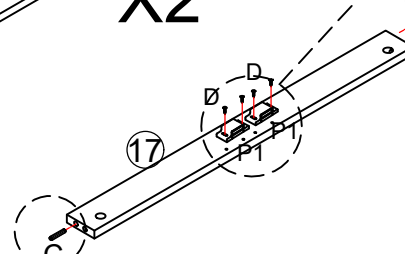
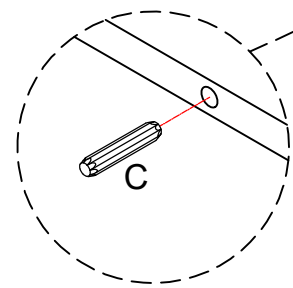
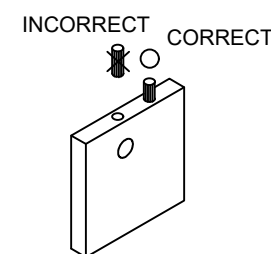
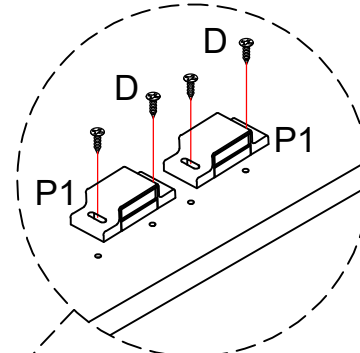
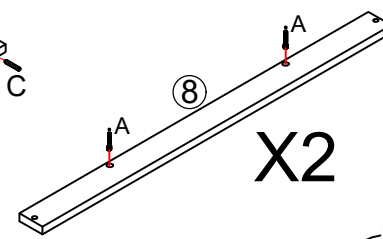
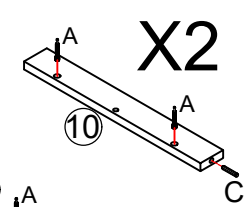
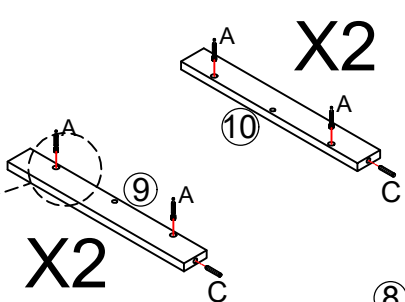
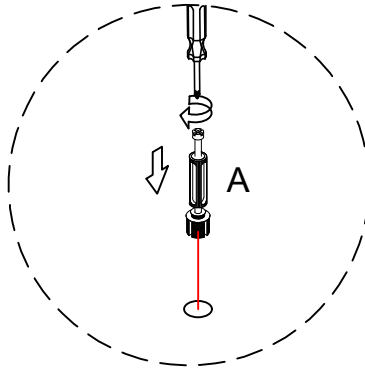

	A*33
	C*4
	D*12
	P1*6

put A on board ①②③④⑤⑥
 put C on board ①

2





	A*28
	C*6
	D*4
	P1*2

put A on board ⑧ ⑨ ⑩ ⑪ ⑫ ⑬ ⑭
 put C on board ⑨ ⑩ ⑰

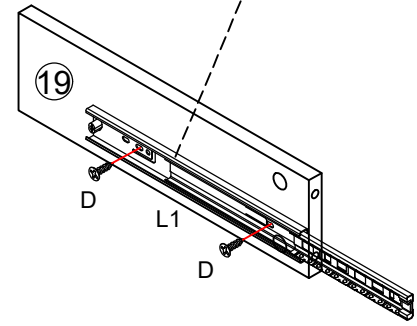
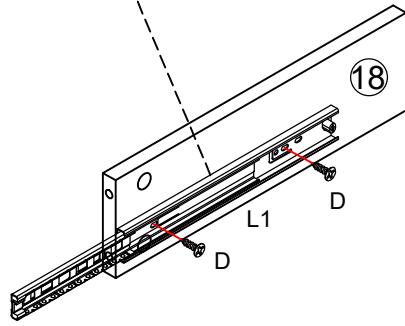
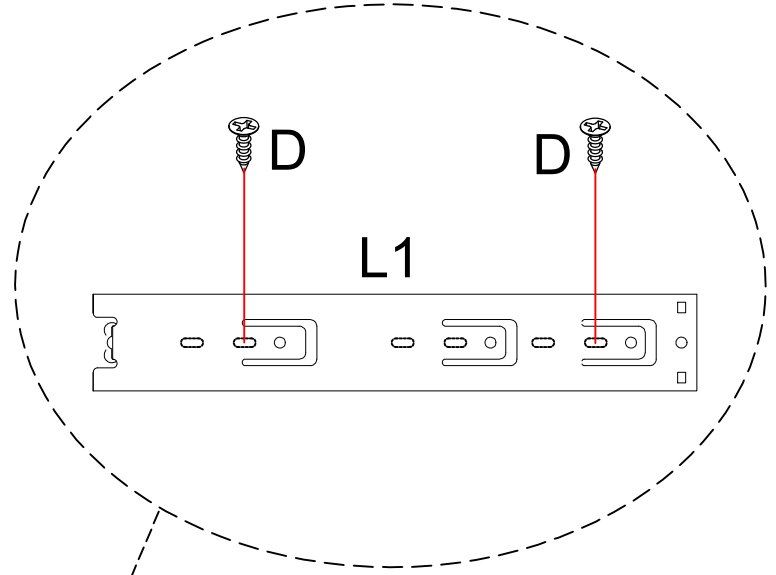
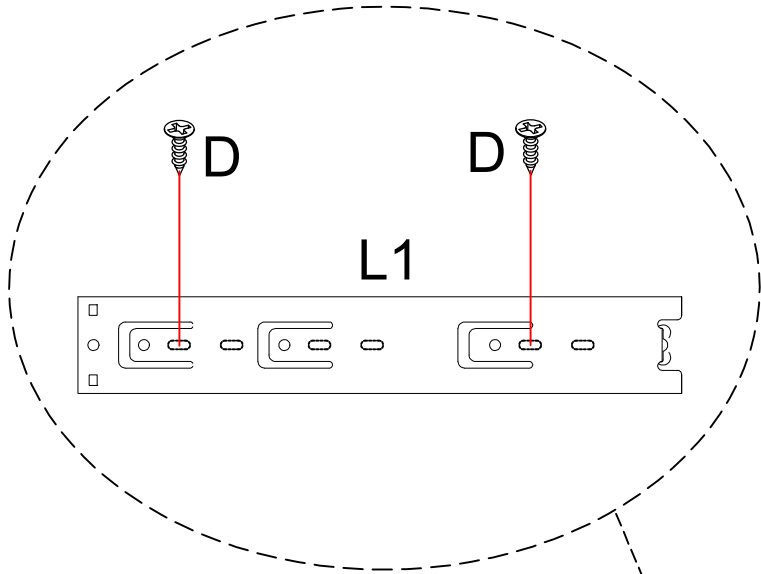
3



	D*4
	L1*1

4

Make sure the arrow on the screw align to the hole on the side.

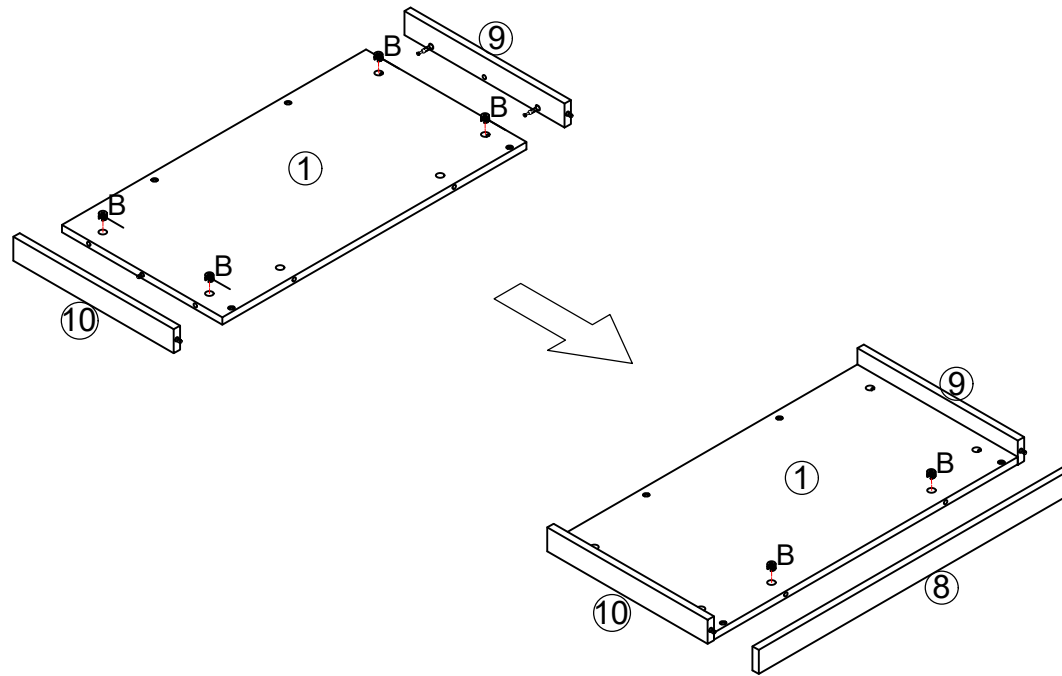
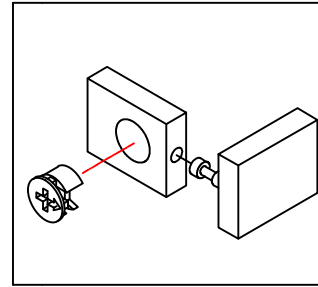

X2



B*12

put B on board ①

5

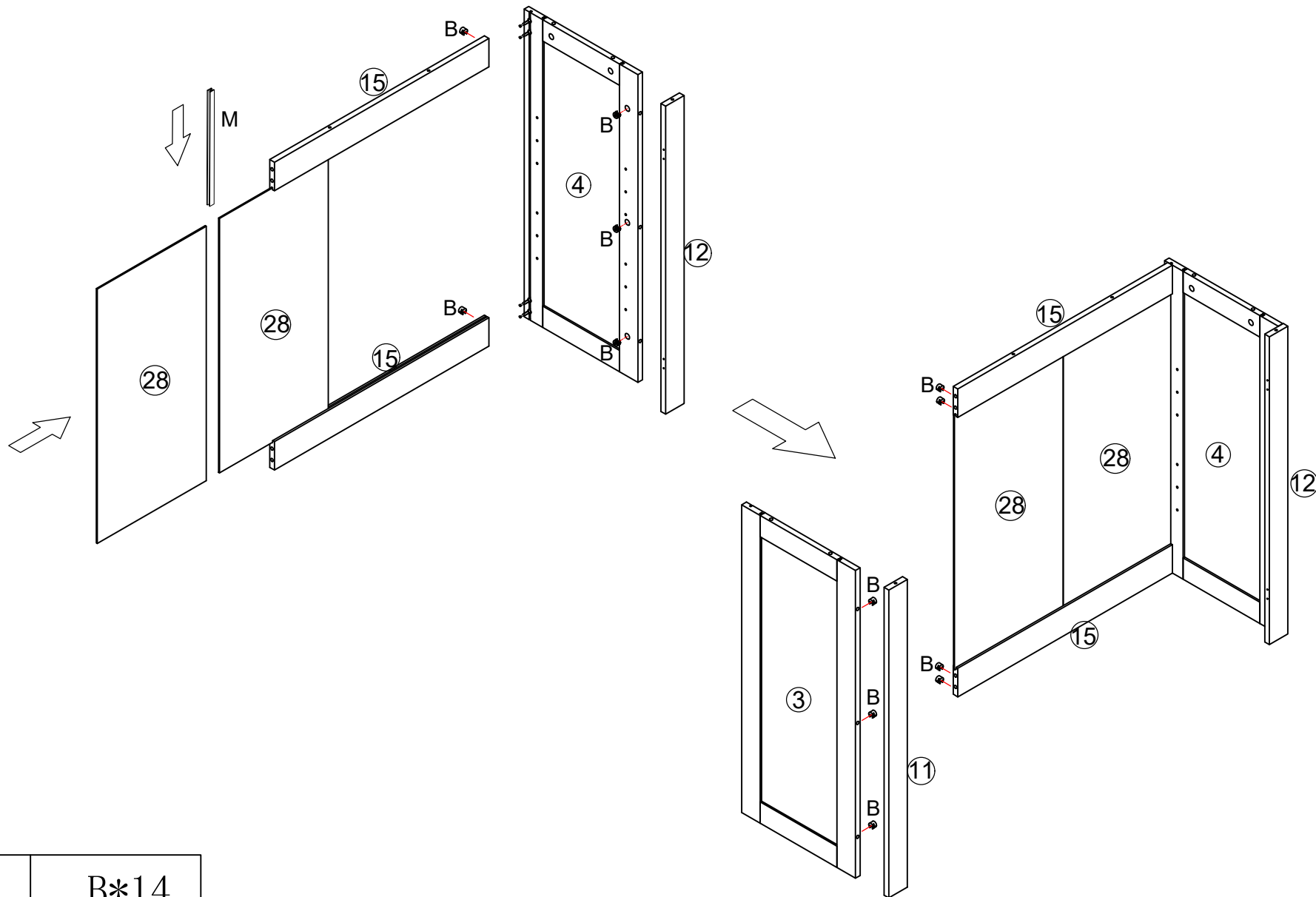

B*14



M*1

put B on board ③ ④ ⑮

6

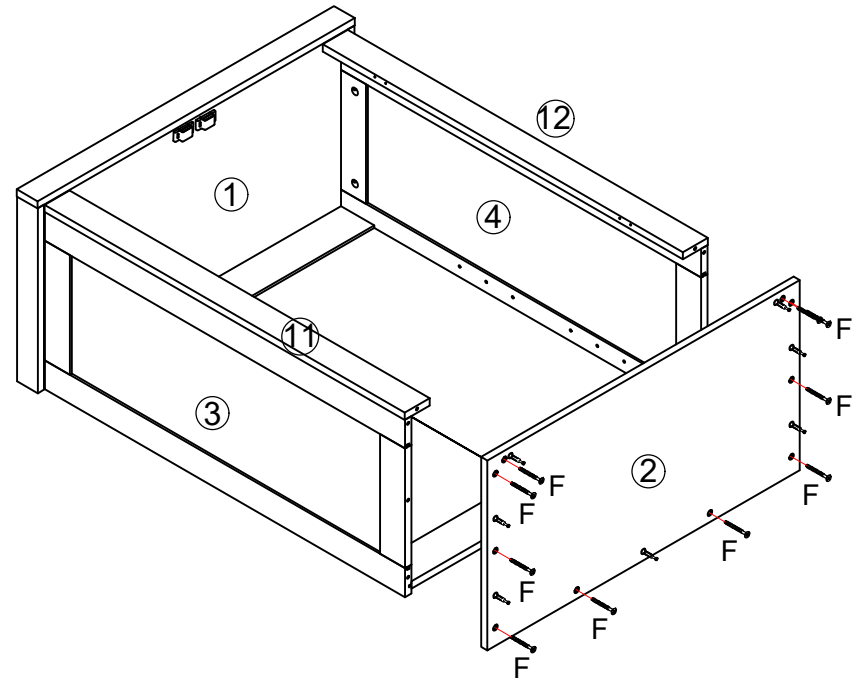
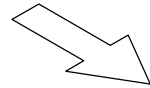
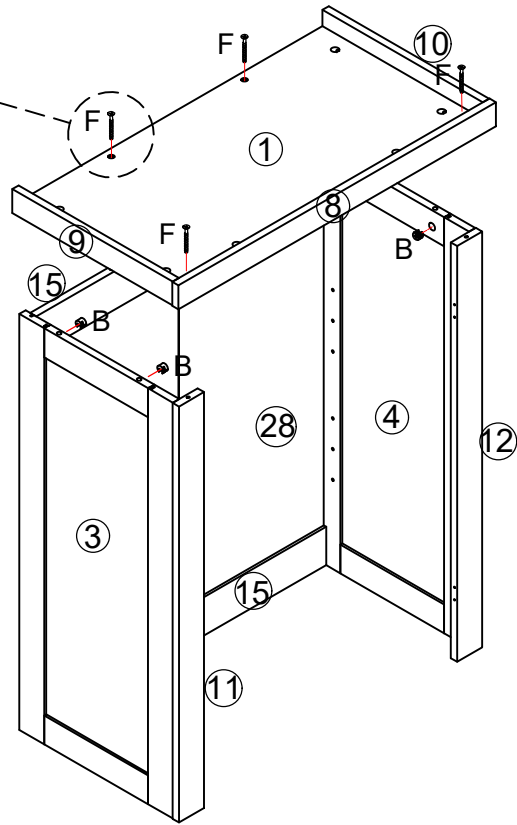
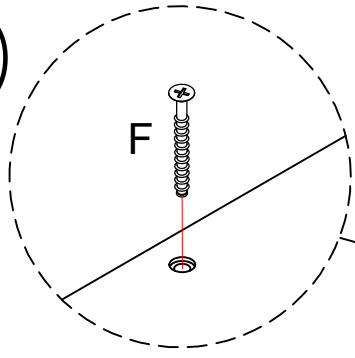

put B on board ③ ④



B*4



F*14

7

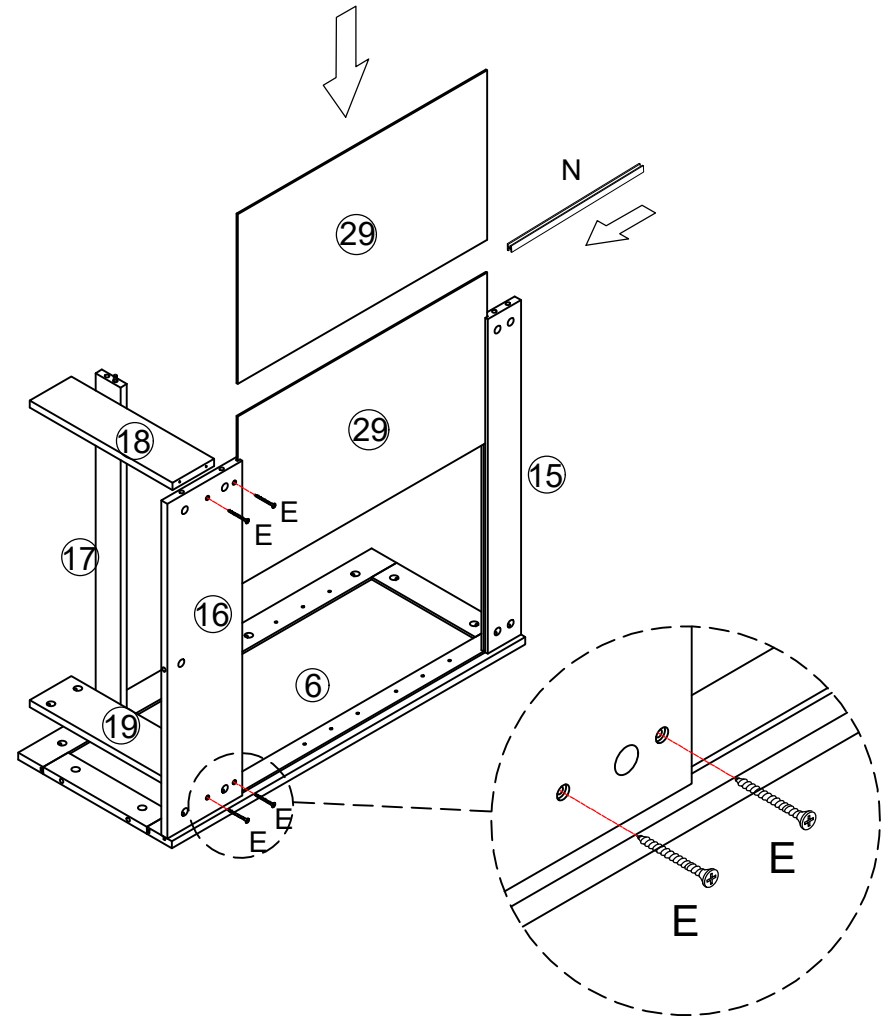
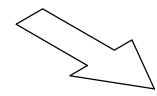
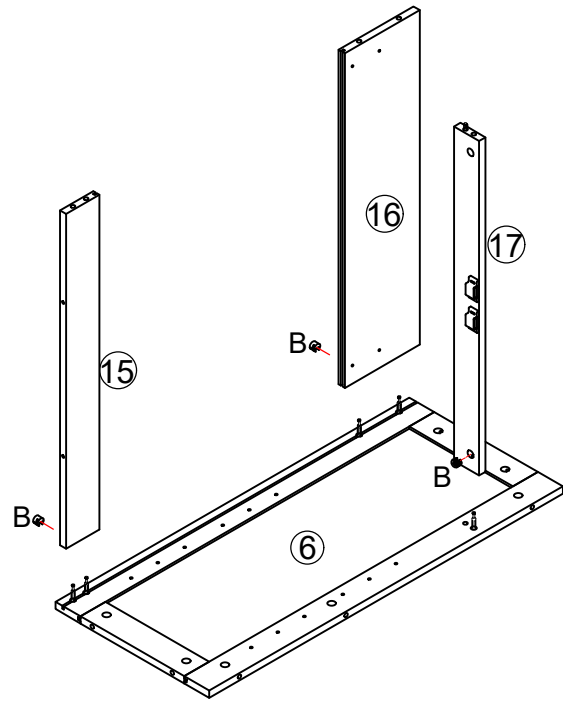

put B on board 15 16 17



B*5

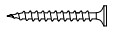

E*4



N*1

8

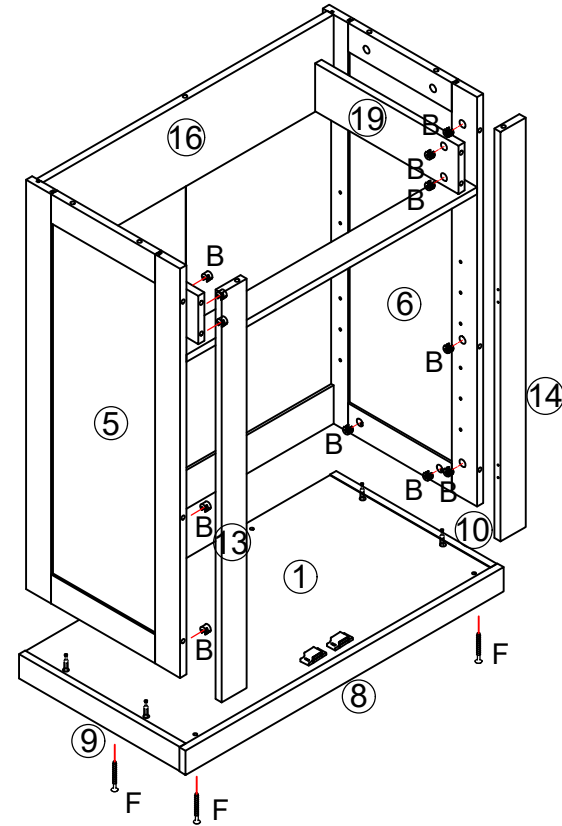
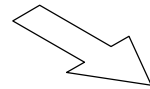
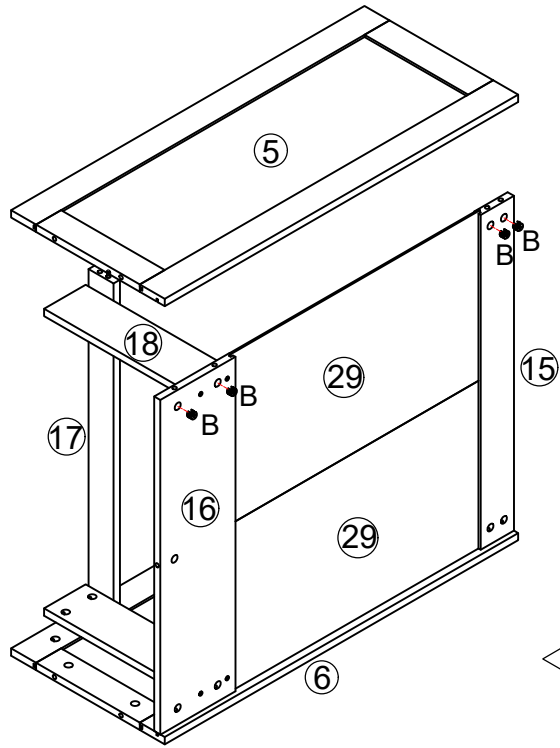

B*19



F*4

put B on board 5 6 15 16 17 18 19

9

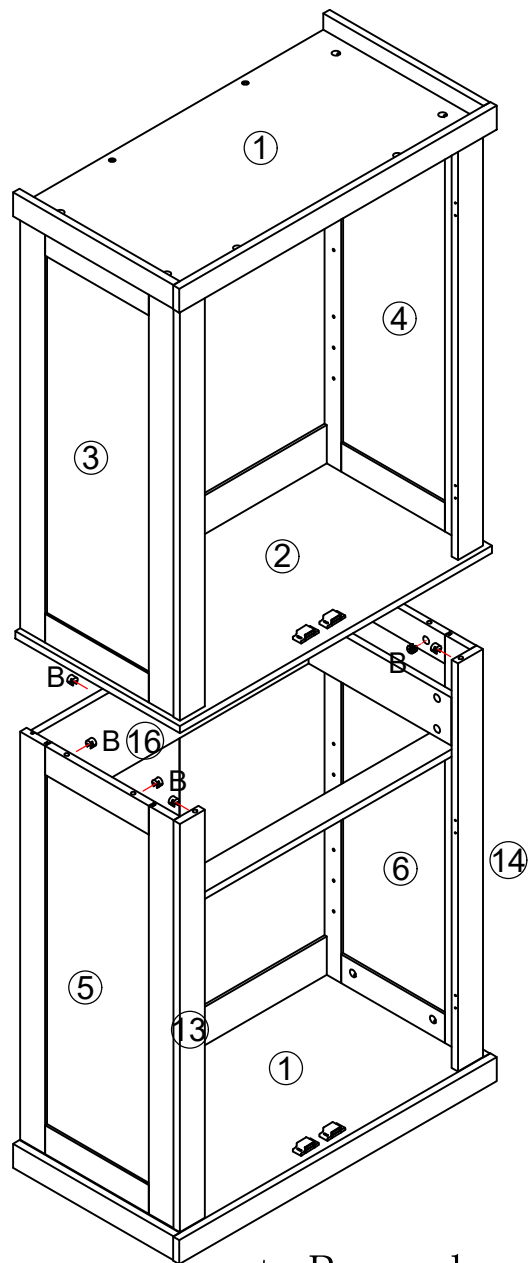

put B on board ⑤ ⑥ ⑬ ⑭ ⑯

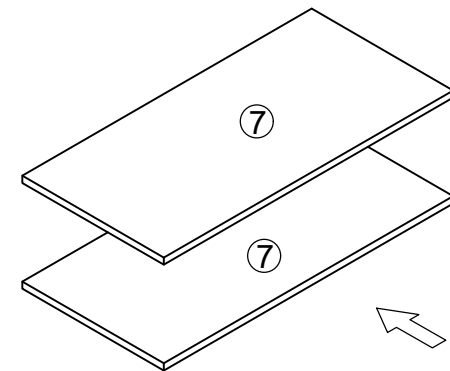
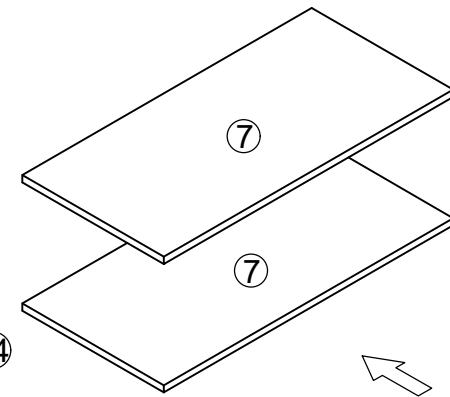
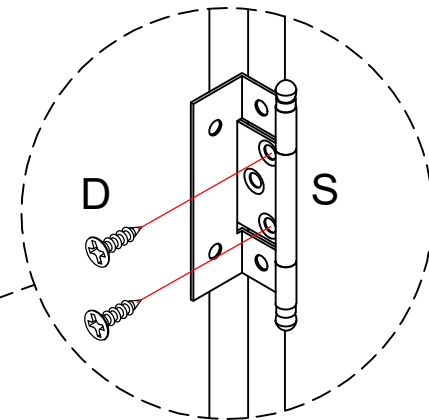
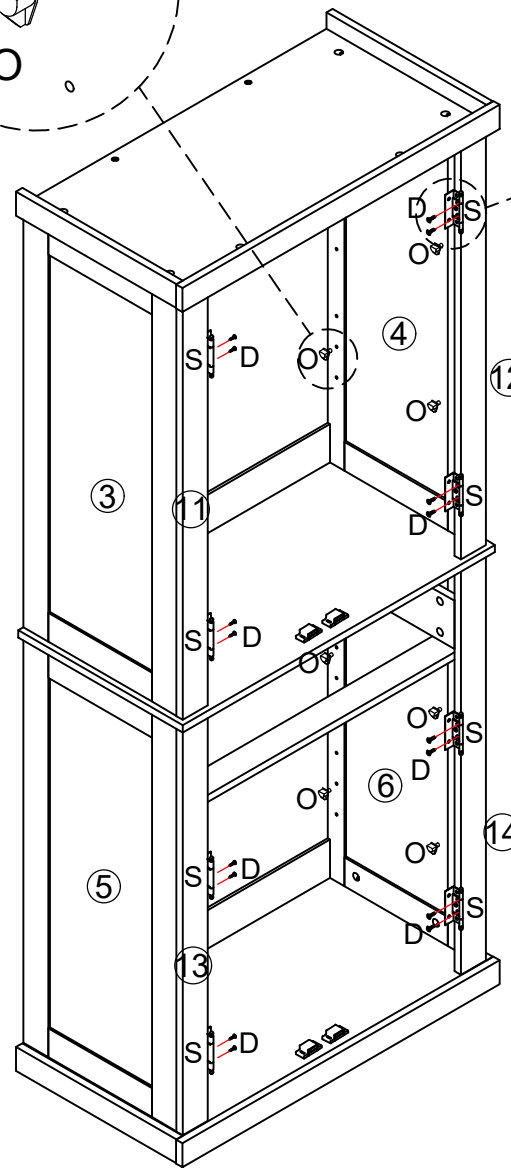
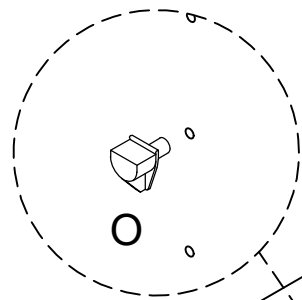

B*7



D*16



O*16



S*8

10

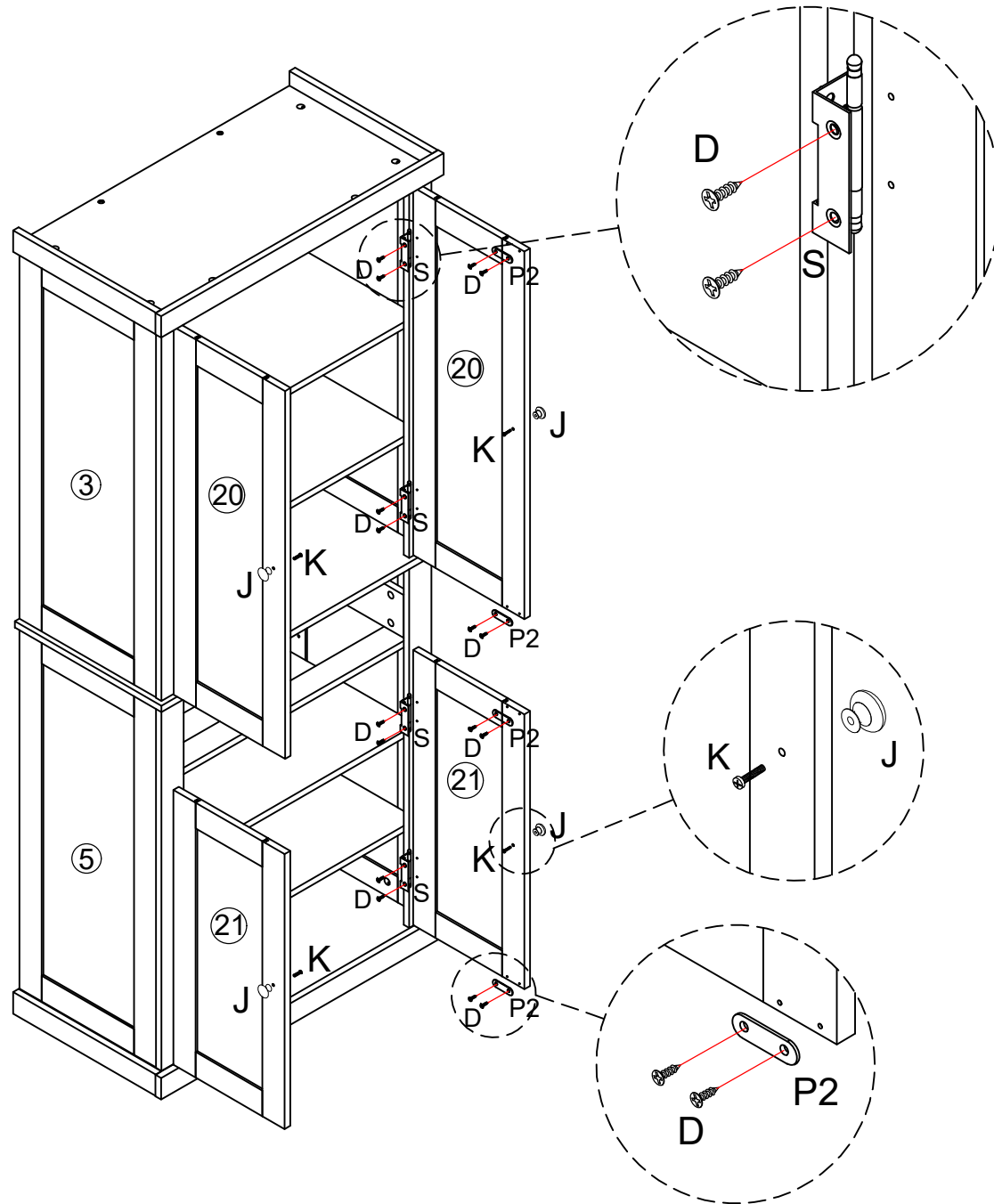

D*32



J*4







K*4

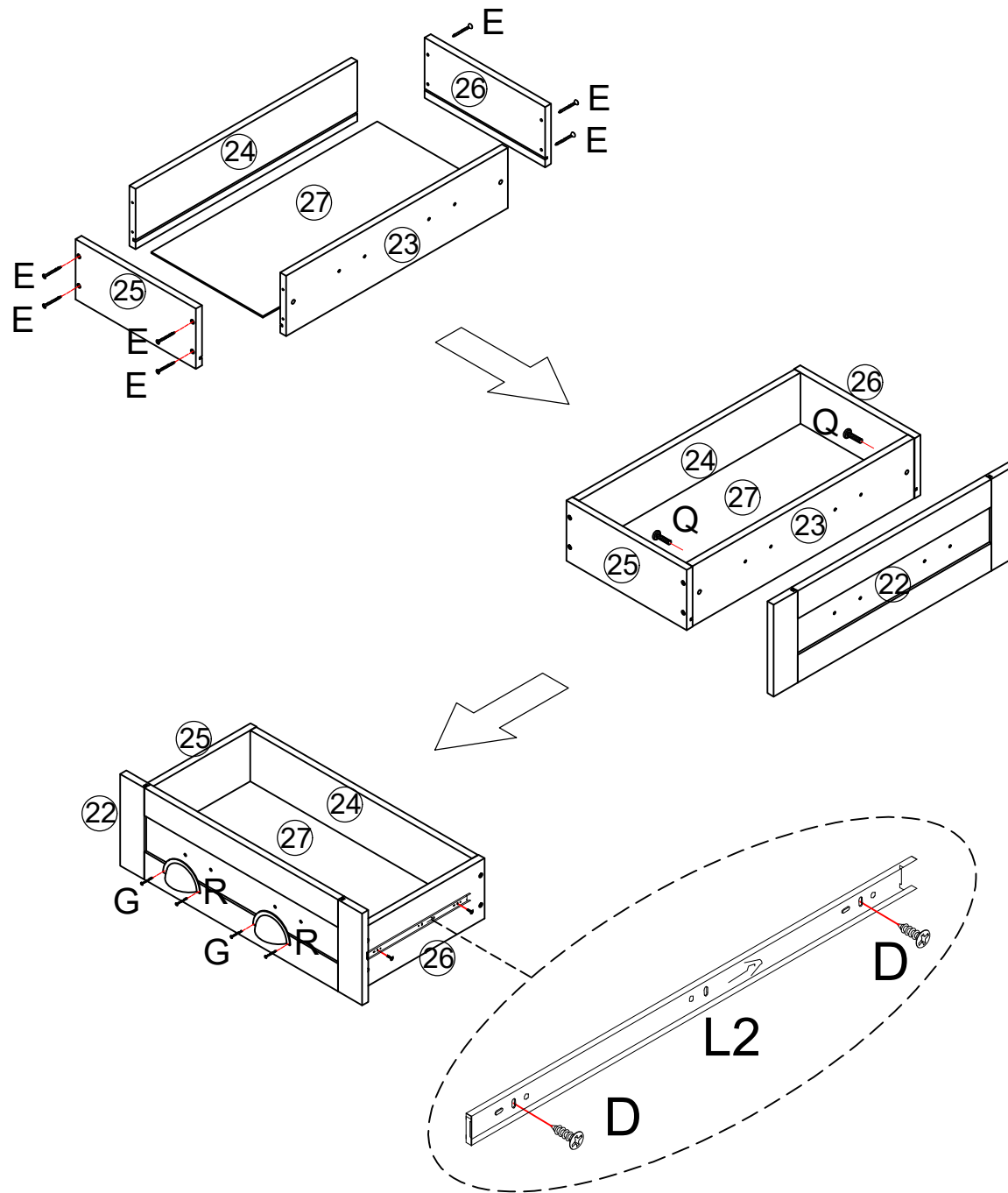

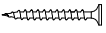
P2*8

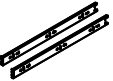

	D*4
	E*8
	G*4
	L2*1
	Q*2
	R*2

12

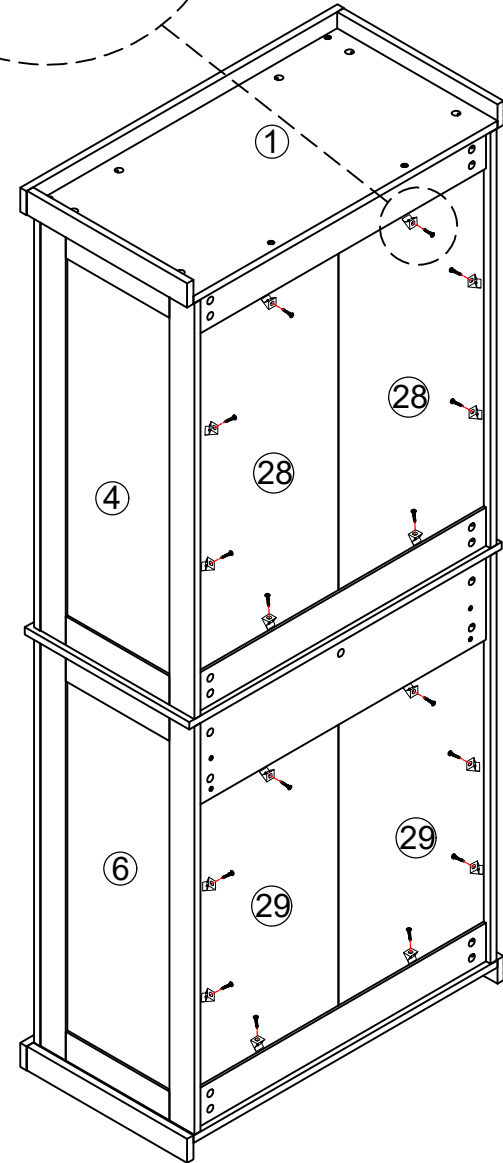
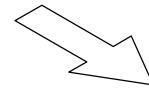
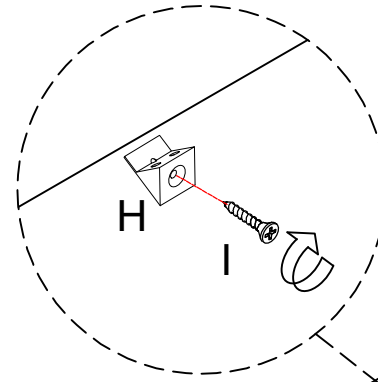
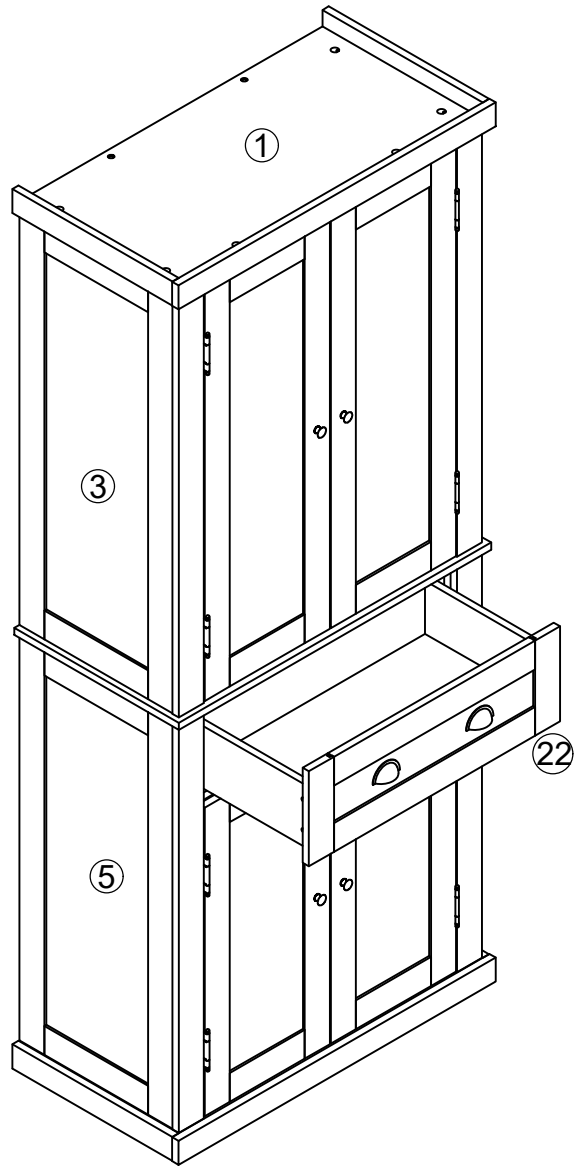

H*16



I*16

13

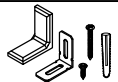
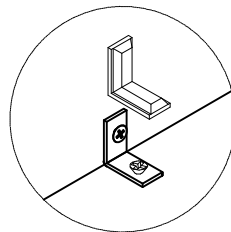
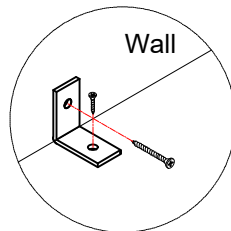
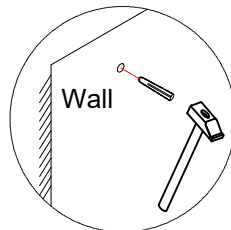
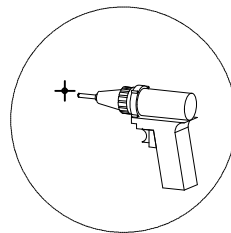
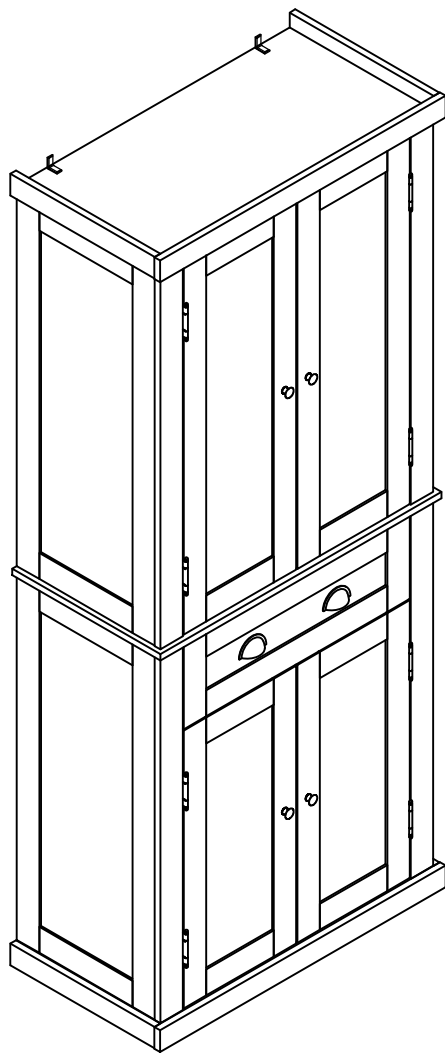

T*2

Please install tip-proof fitting.