

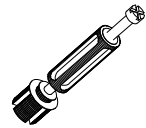

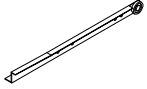





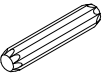
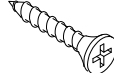
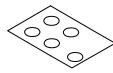

<p>A</p>  <p>41PCS</p>	<p>H 250MM</p>  <p>4PCS</p>	<p>O 100MM</p>  <p>4PCS</p>
<p>B</p>  <p>41PCS</p>	<p>I 3*12</p>  <p>8PCS</p>	<p>P 559MM</p>  <p>1PCS</p>
<p>C 8*40</p>  <p>6PCS</p>	<p>J 3.5*14</p>  <p>52PCS</p>	<p>Q</p>  <p>5PCS</p>
<p>D 7*50</p>  <p>10PCS</p>	<p>K 3.5*35</p>  <p>16PCS</p>	<p>R</p>  <p>2PCS</p>
<p>E 250MM</p>  <p>4PCS</p>	<p>L</p>  <p>8PCS</p>	
<p>F 250MM</p>  <p>4PCS</p>	<p>M $\phi 60$</p>  <p>2PCS</p>	
<p>G 250MM</p>  <p>4PCS</p>	<p>N</p>  <p>4PCS</p>	

<p>1</p>  <p>408*300 1 PCS</p>	<p>2</p>  <p>440*300 1 PCS</p>	<p>3</p>  <p>695*300 1 PCS</p>	<p>4</p>  <p>695*300 1 PCS</p>	<p>5</p>  <p>408*119 1 PCS</p>
<p>6</p>  <p>408*60 4 PCS</p>	<p>7</p>  <p>280*120 1 PCS</p>	<p>8</p>  <p>100*100 1 PCS</p>	<p>9</p>  <p>571*209 2 PCS</p>	<p>10</p>  <p>404*125 4 PCS</p>
<p>11</p>  <p>250*90 4 PCS</p>	<p>12</p>  <p>250*90 4 PCS</p>	<p>13</p>  <p>353*90 4 PCS</p>	<p>14</p>  <p>363*244 4 PCS</p>	

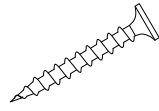
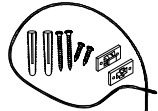
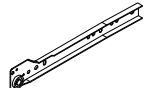

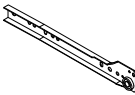
Hardware installation demonstration

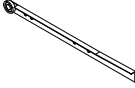
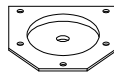
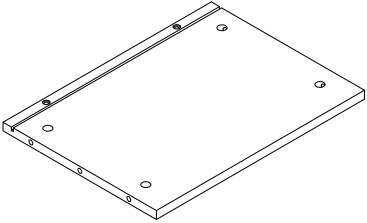
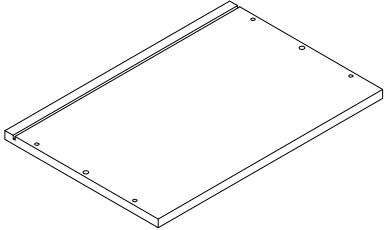
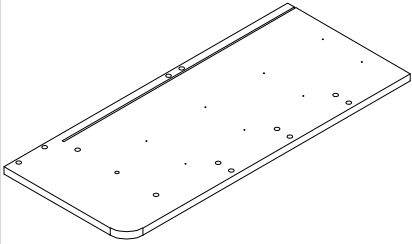
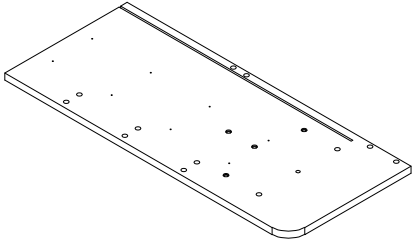
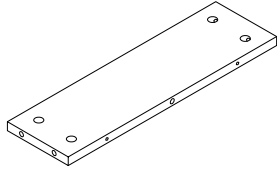
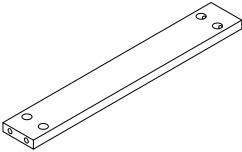
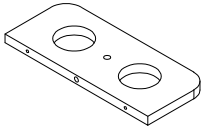
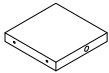
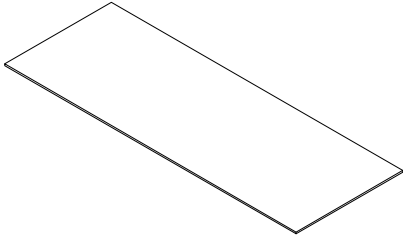
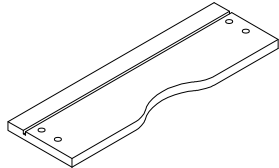
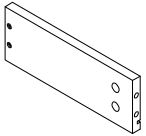
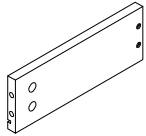
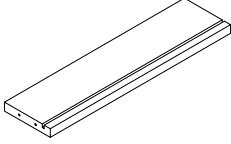
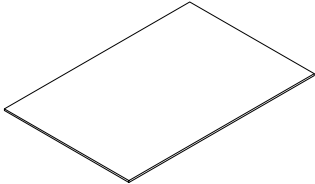
NOTE: Please make sure "A" hardware tightened and can't be pulled out!

I

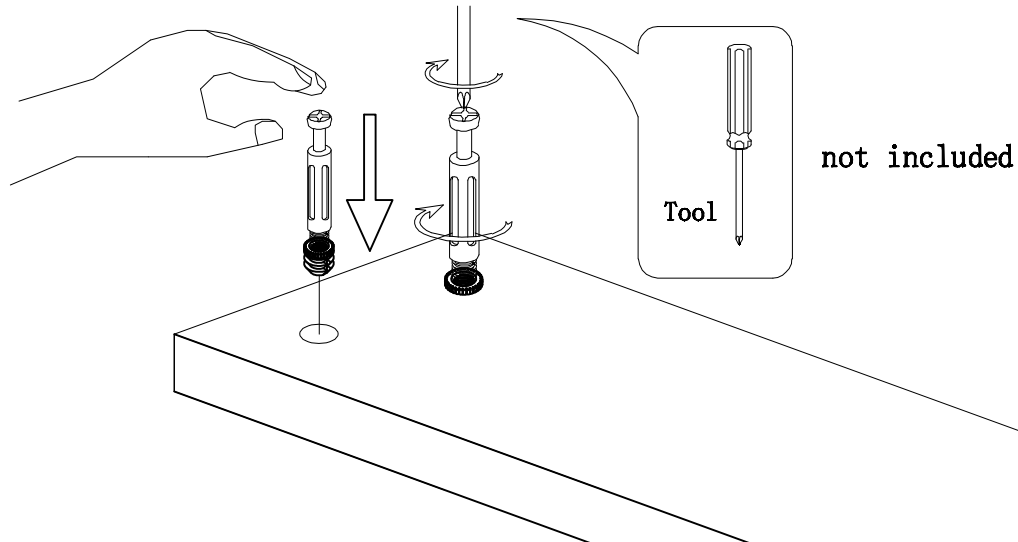

II

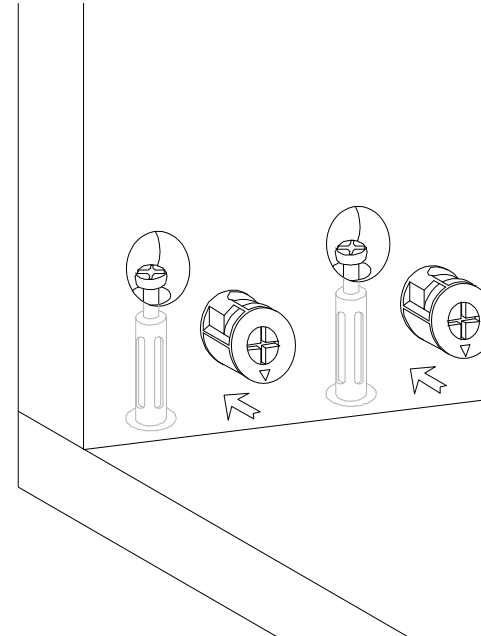

III

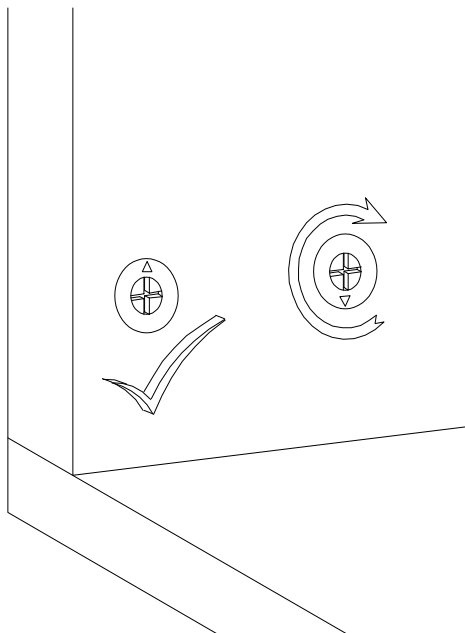

IV





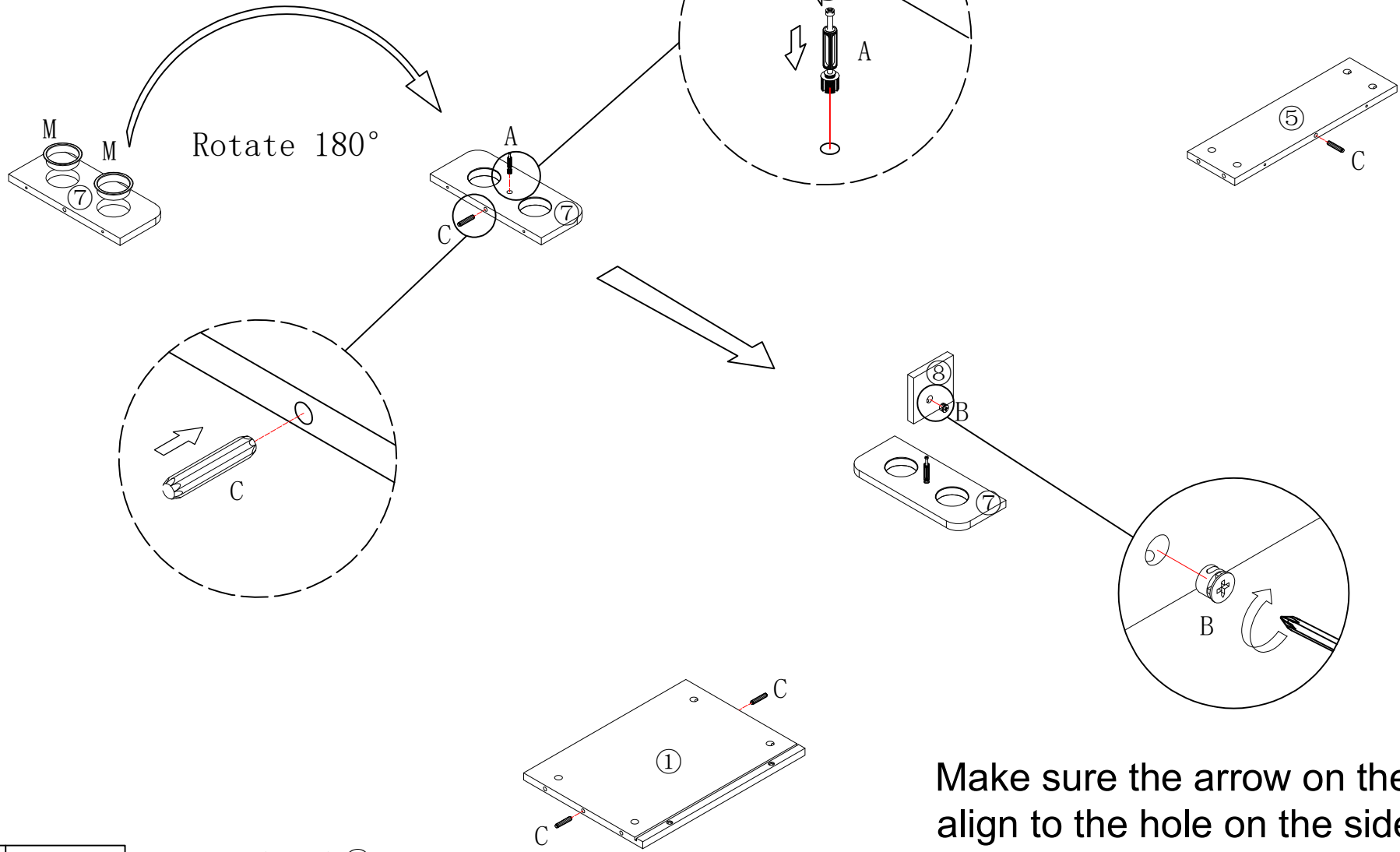

Scan QR code for assembly video

1







Make sure the arrow on the screw align to the hole on the side.

	A*1
	B*1
	C*4
	M*2

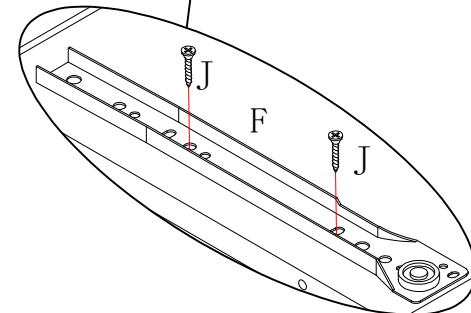
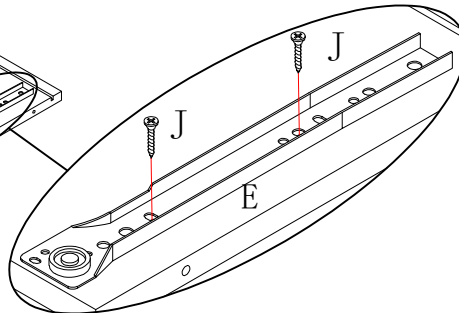
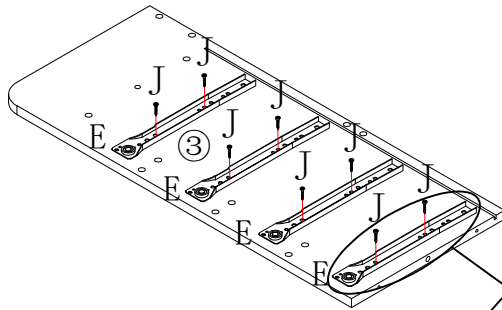
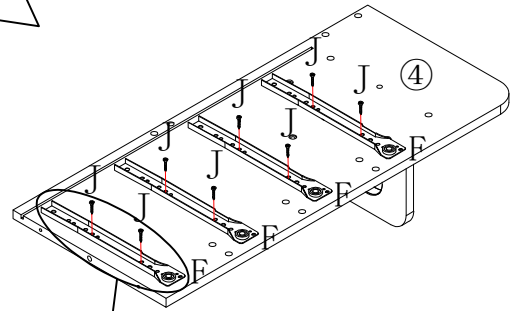
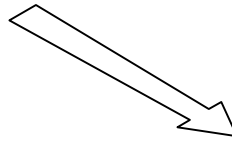
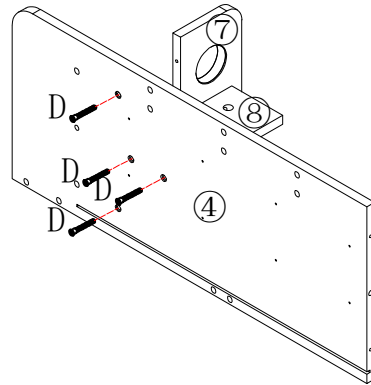
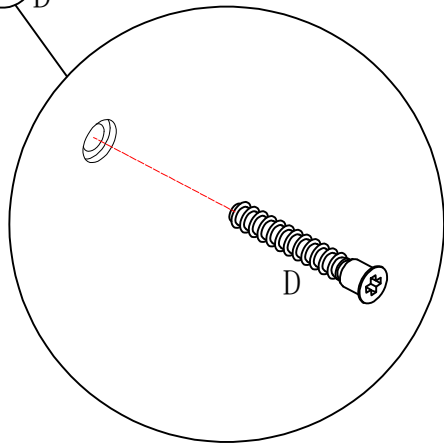
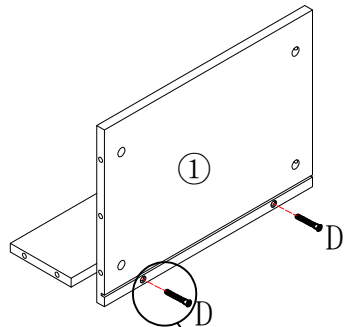
put A on board ⑦
put B on board ⑧
put C on board ①⑤

2



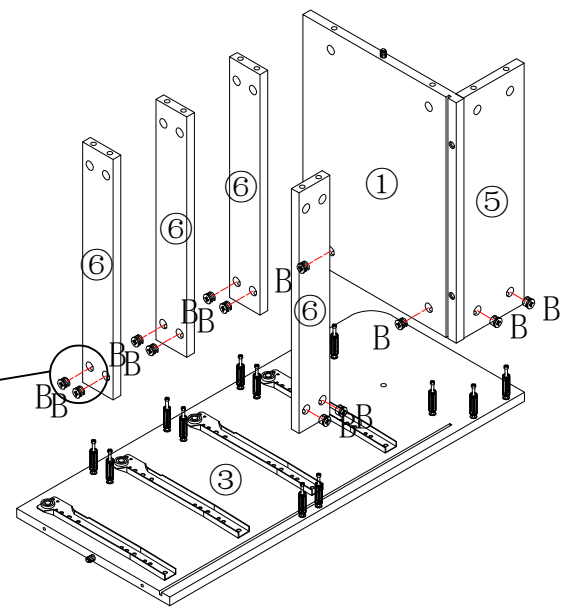
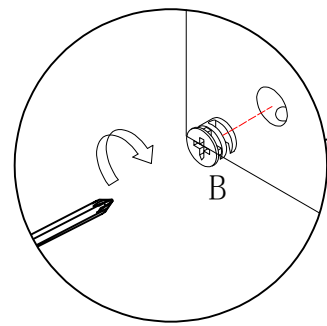
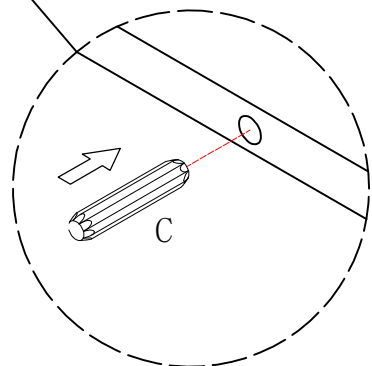
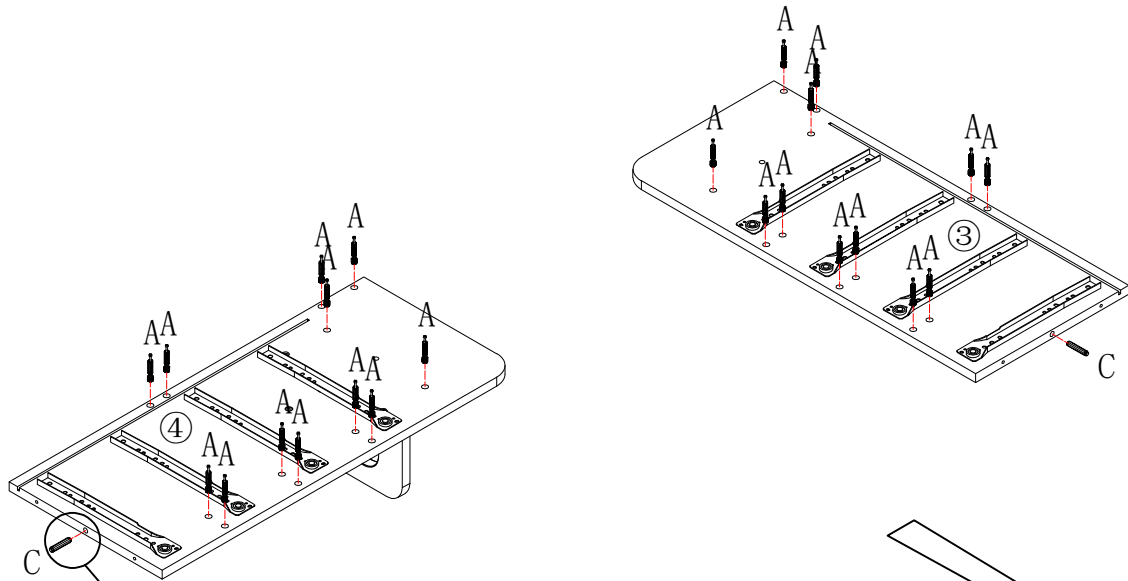

	D*6
	E*4
	F*4
	J*16

3





Make sure the arrow on the screw align to the hole on the side.

	A*24	put A on board ③④
	B*12	put B on board ①⑤⑥
	C*2	put C on board ③④

4

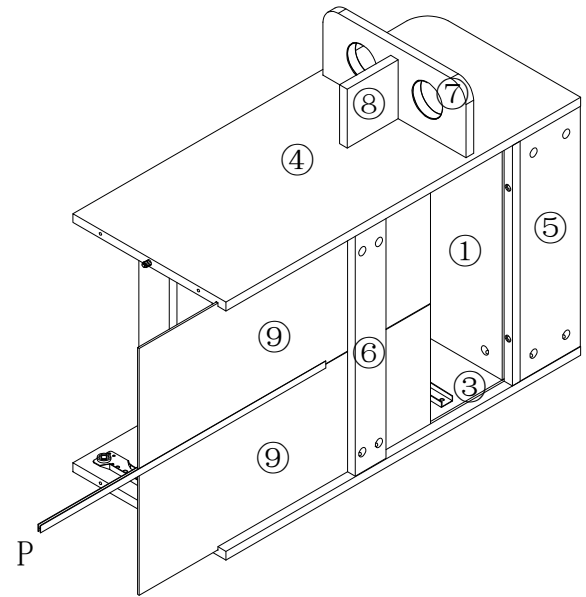
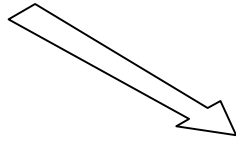
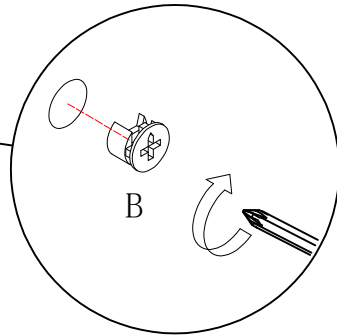
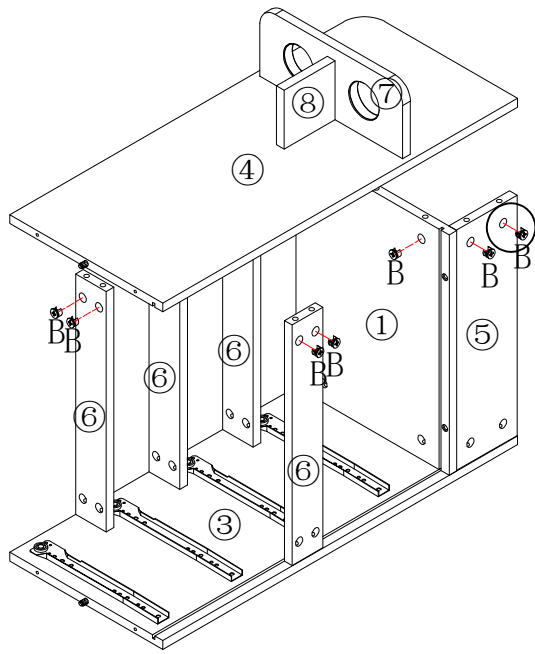
Make sure the arrow on the screw align to the hole on the side.





	B*12
	P*1

put B on board ①⑤⑥

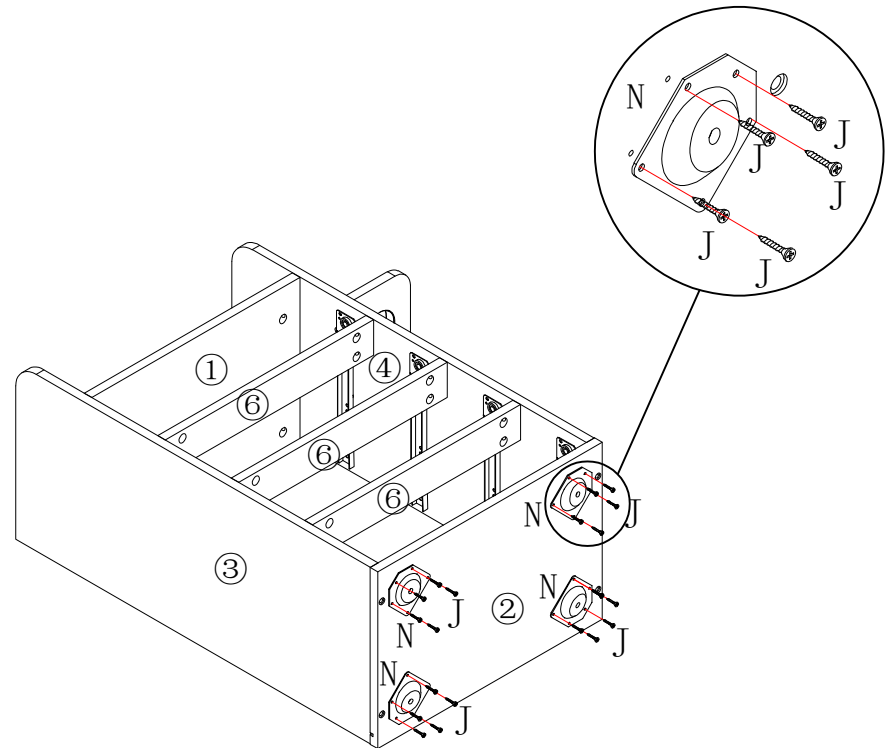
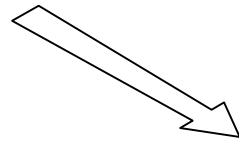
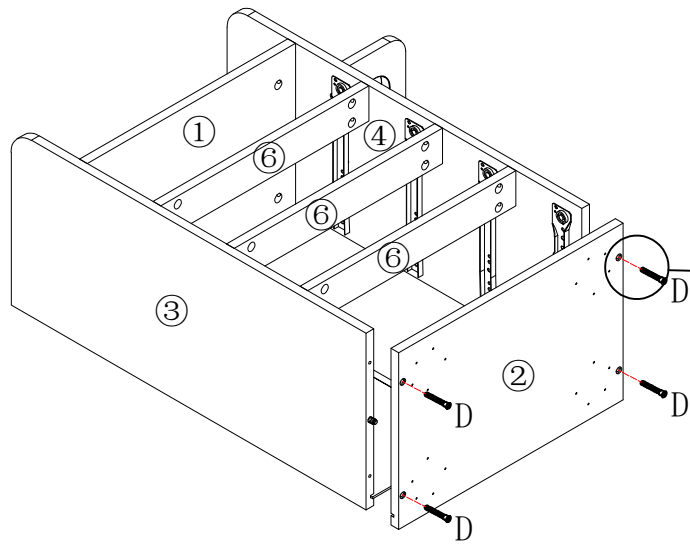

5



	D*4
	J*20
	N*4

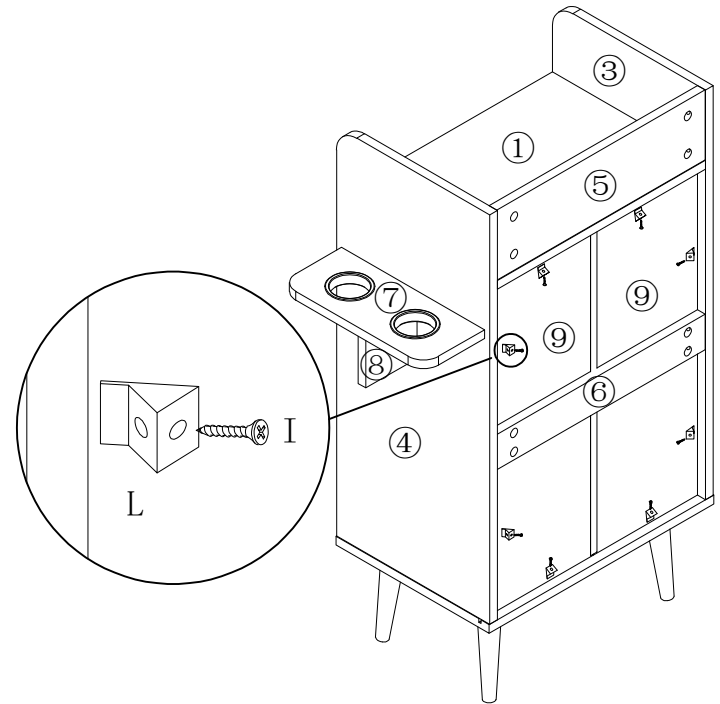
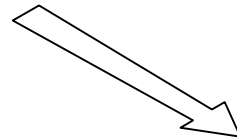
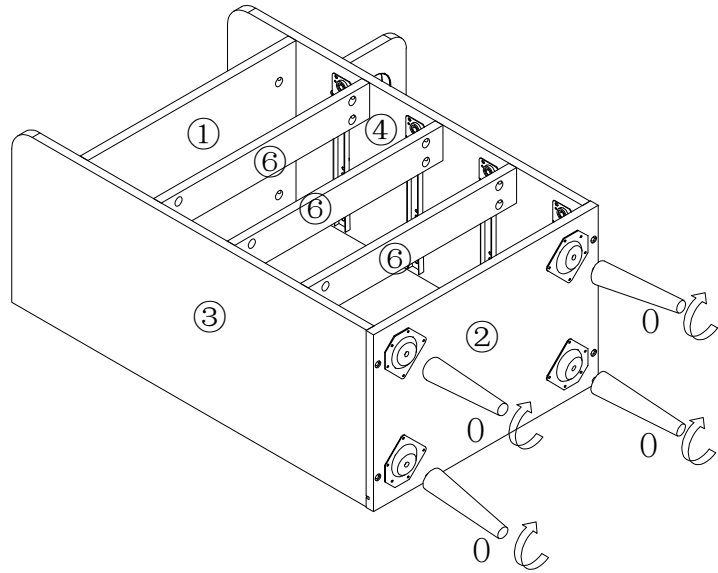

6

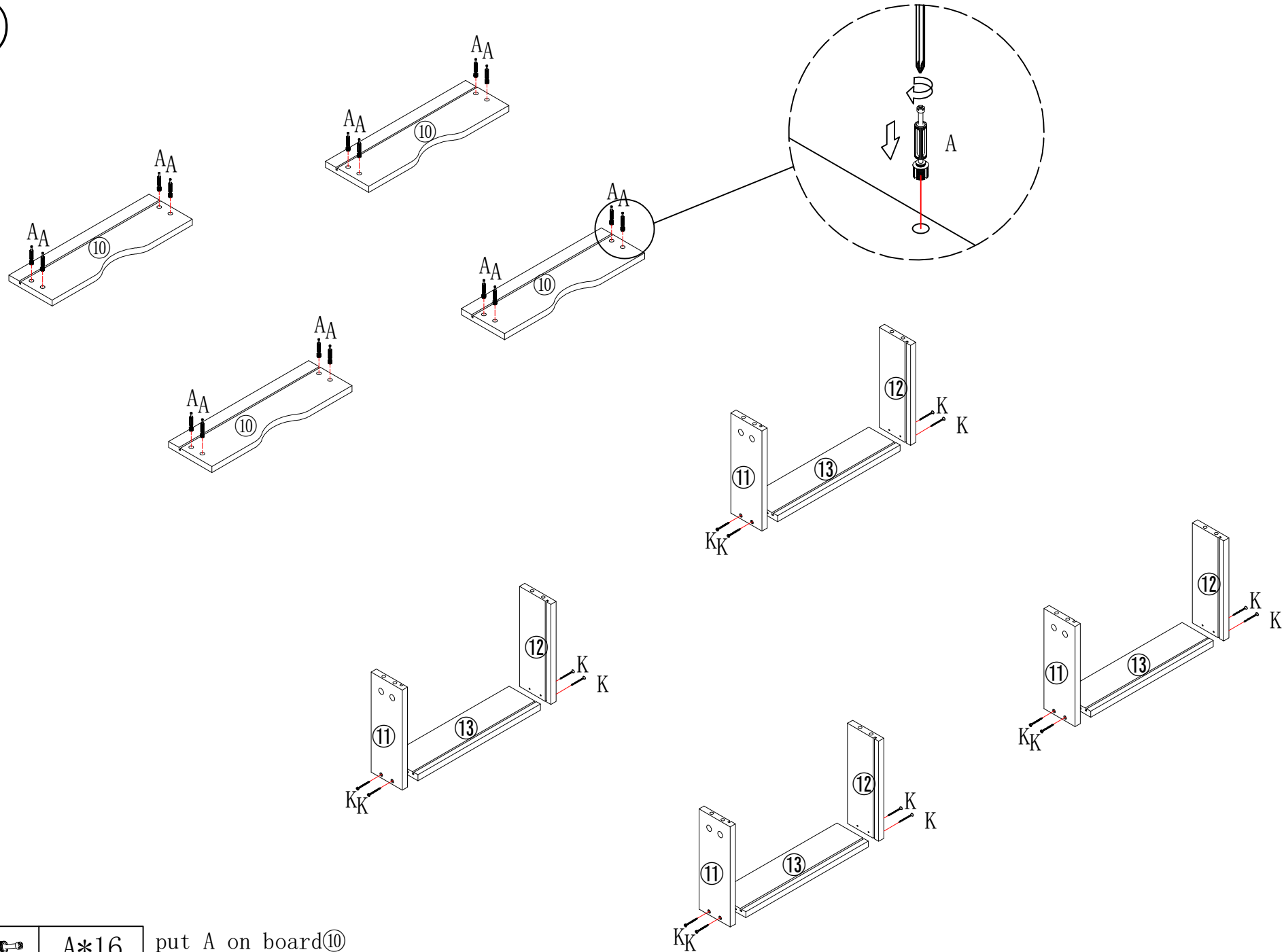

	I*8
	L*8
	0*4

7



	A*16
	K*16

put A on board⑩

8

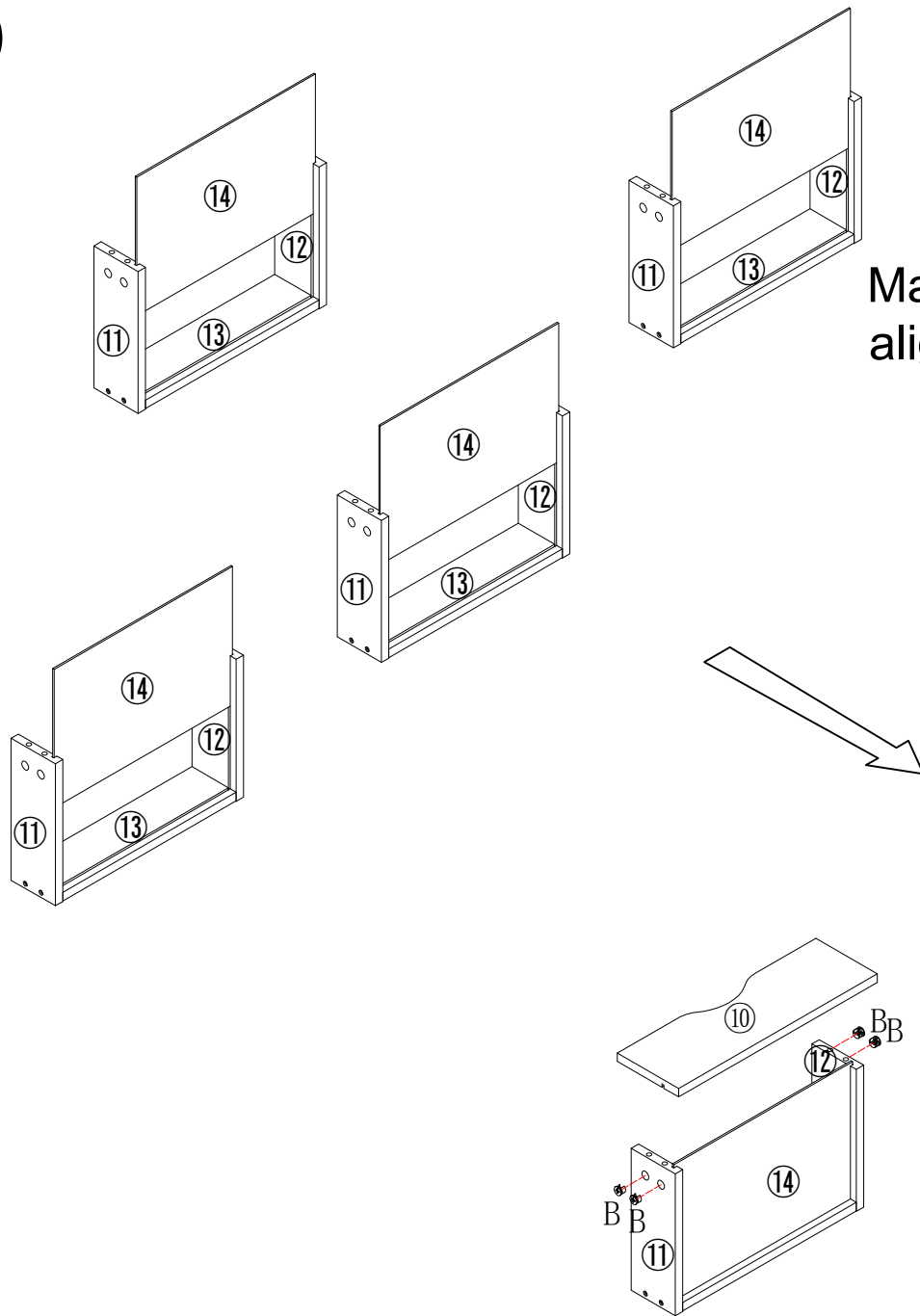



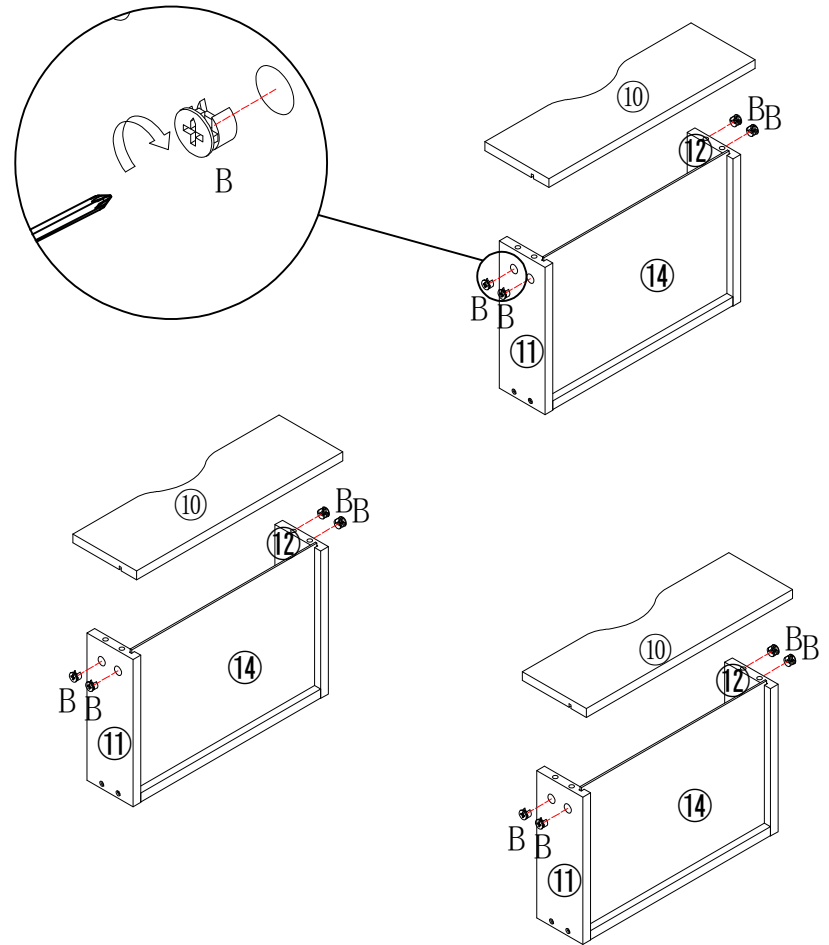

Make sure the arrow on the screw align to the hole on the side.

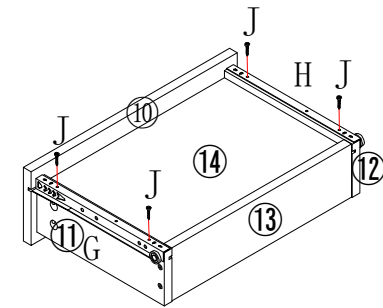
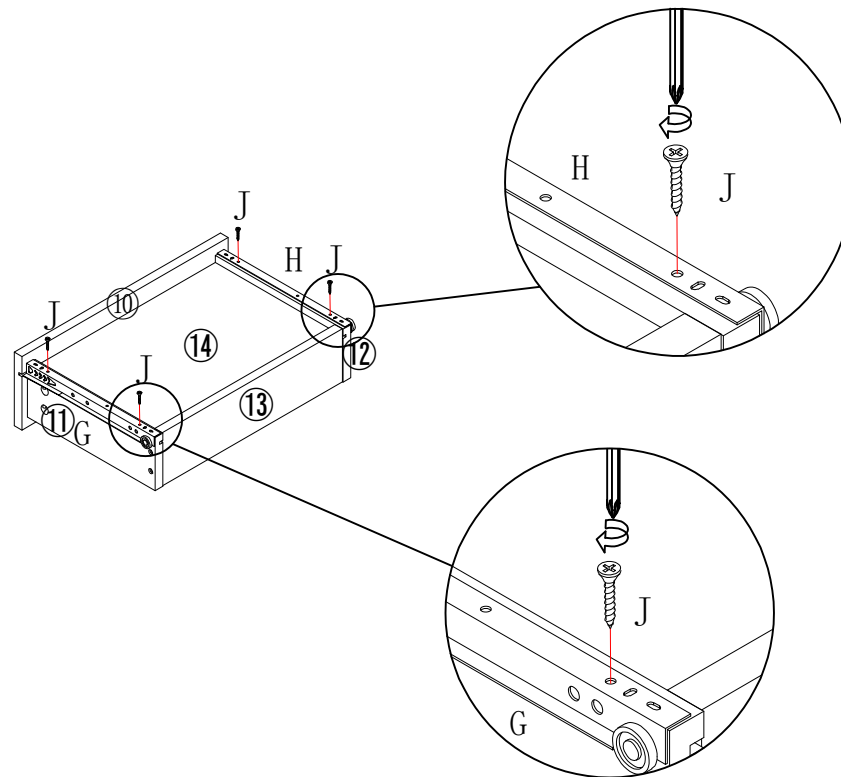
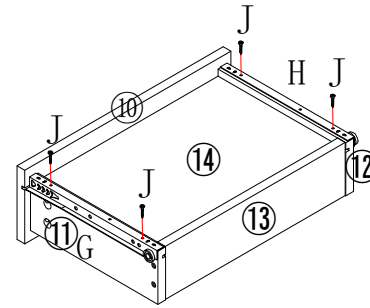
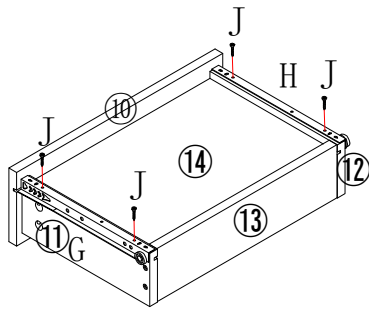

B*16 put B on board 11/12

9



	G*4
	H*4
	J*16

10

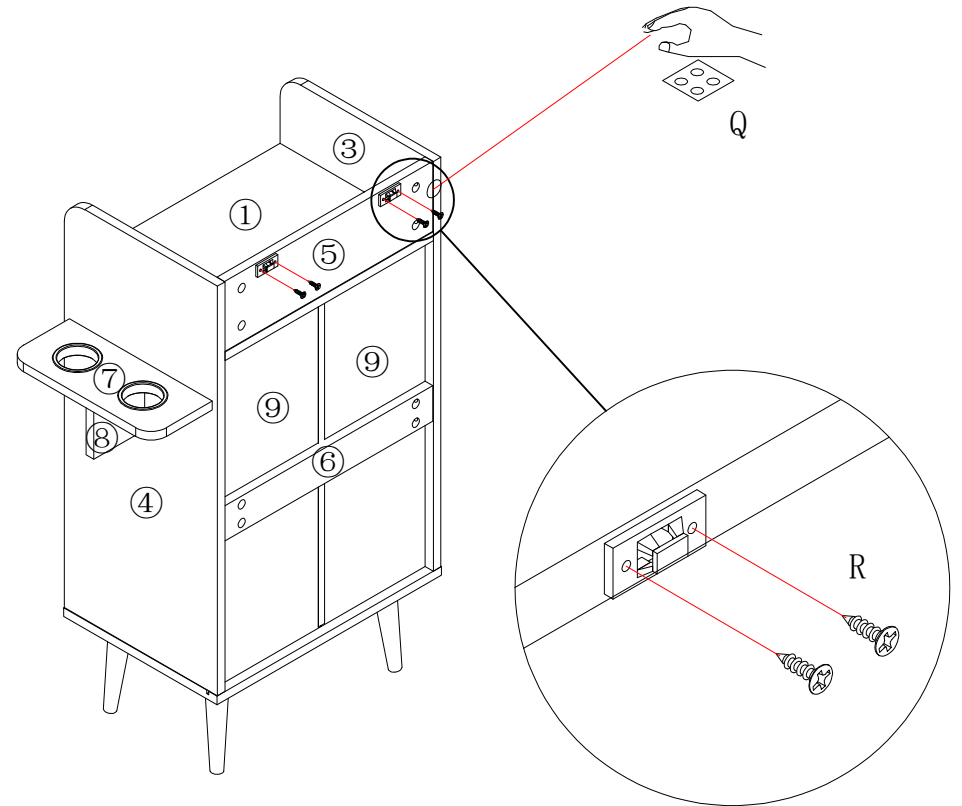
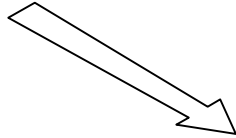
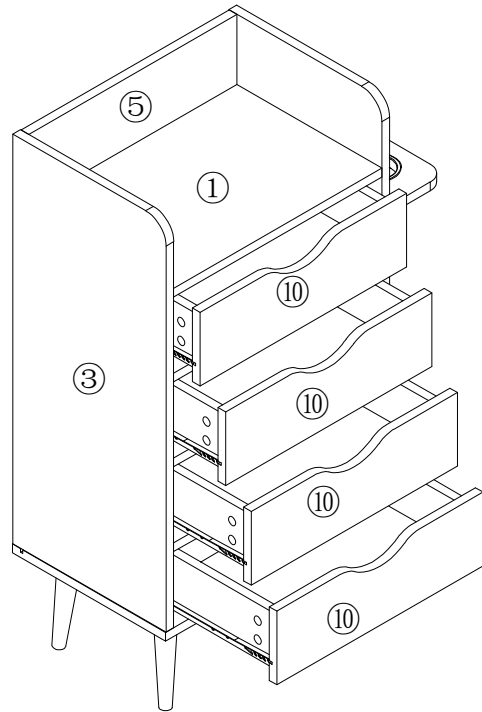

Q*5



R*2

11

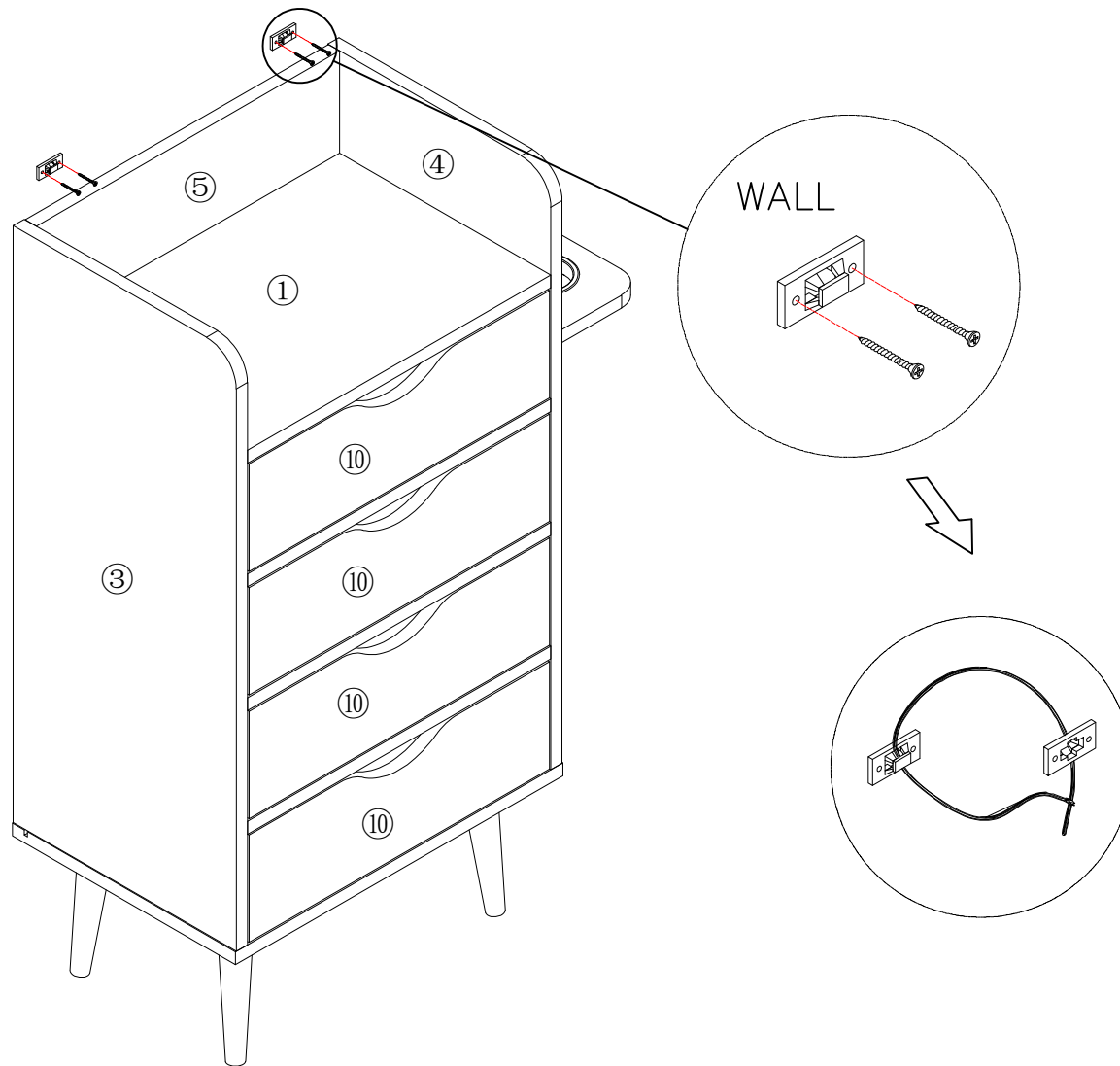

12

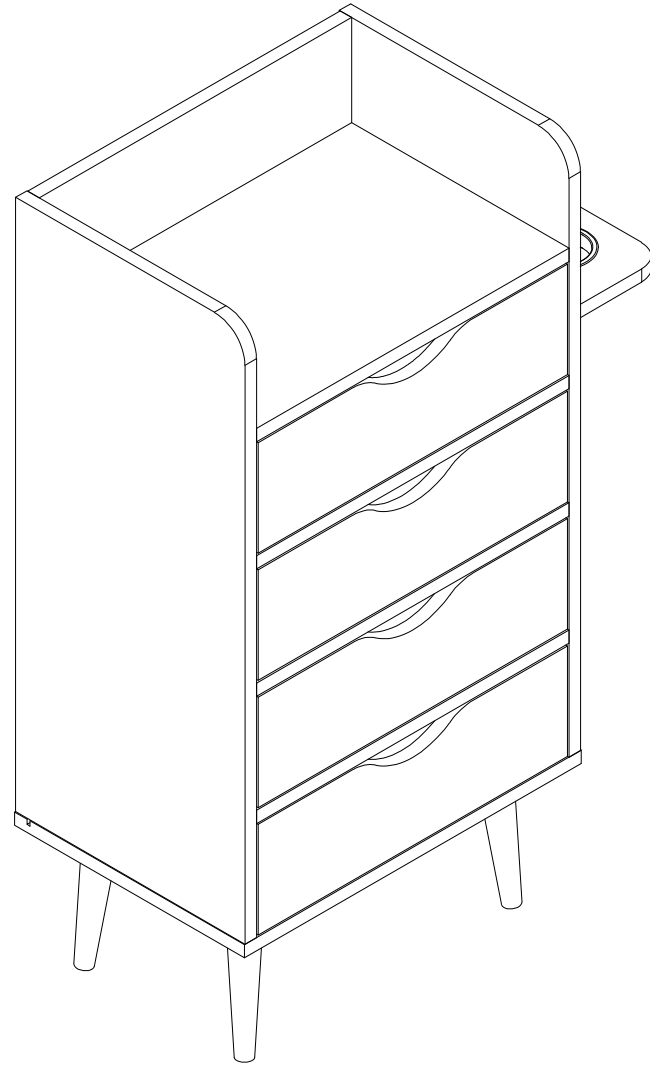

---END---