

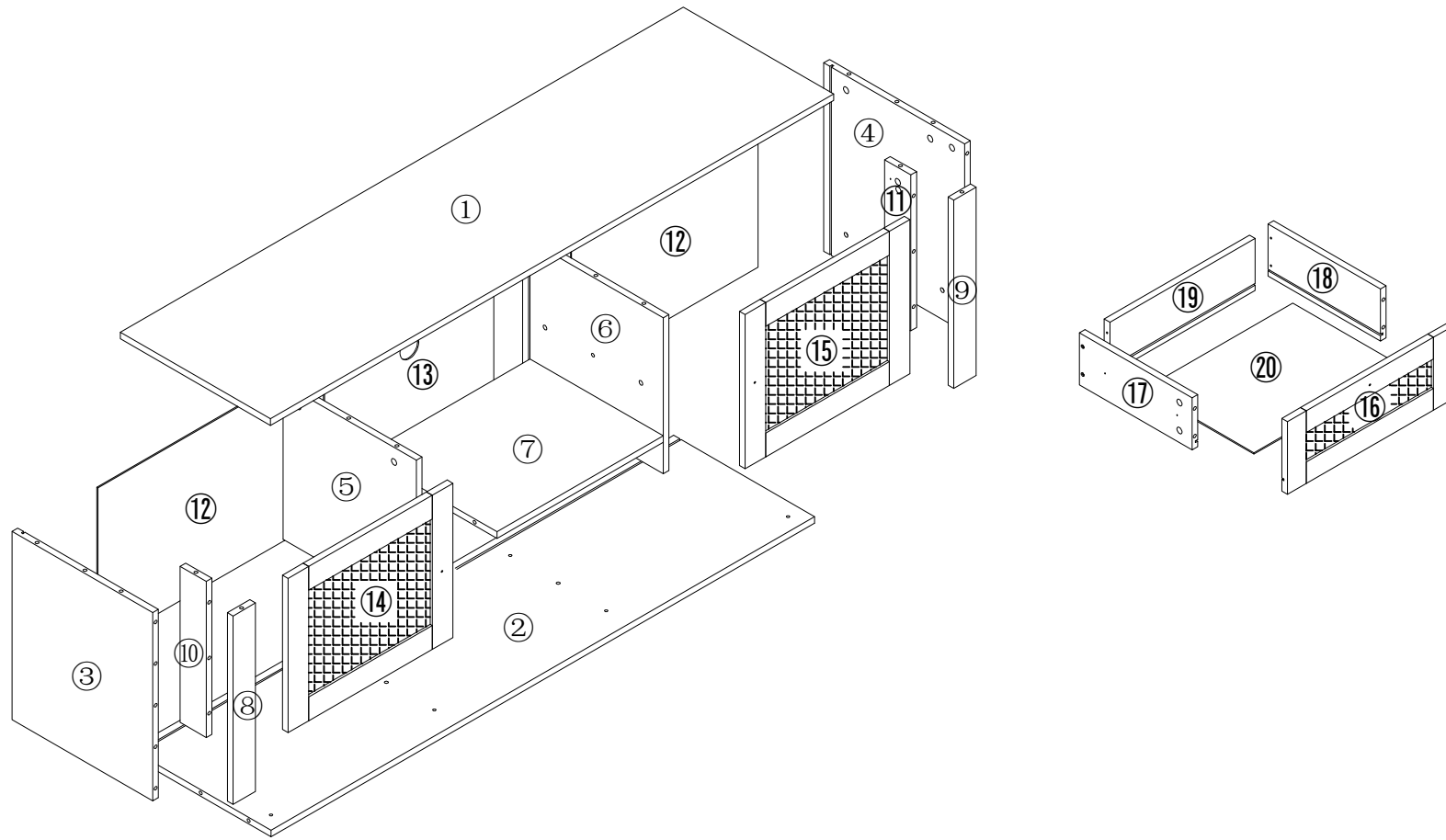

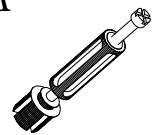





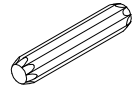

H23060 QD

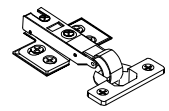
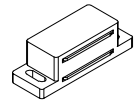
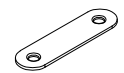

A  30PCS	B  32PCS	C 8*40  20PCS	D 7*50  6PCS	E  4PCS	F  2PCS	G  2PCS	H  3PCS	I 4*20  3PCS	J 3*12  16PCS
K 3.5*14  44PCS	L 3.5*35  4PCS	M 60MM  2PCS	N  12PCS	O  0*2 0 ₁ *2 0 ₂ *2	P  1PCS 2PCS				

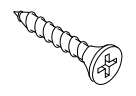
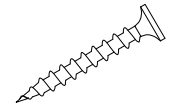
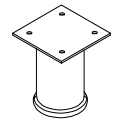
<p>1</p>  <p>1500*400 1 PCS</p>	<p>2</p>  <p>1448*375 1 PCS</p>	<p>3</p>  <p>435*375 1 PCS</p>	<p>4</p>  <p>435*375 1 PCS</p>	<p>5</p>  <p>360*375 1 PCS</p>
<p>6</p>  <p>360*375 1 PCS</p>	<p>7</p>  <p>443*355 1 PCS</p>	<p>8</p>  <p>435*60 1 PCS</p>	<p>9</p>  <p>435*60 1 PCS</p>	<p>10</p>  <p>360*70 1 PCS</p>
<p>11</p>  <p>360*70 1 PCS</p>	<p>12</p>  <p>370*497 2 PCS</p>	<p>13</p>  <p>370*451 1 PCS</p>	<p>14</p>  <p>356*439 1 PCS</p>	<p>15</p>  <p>356*439 1 PCS</p>
<p>16</p>  <p>439*168 1 PCS</p>	<p>17</p>  <p>300*120 1 PCS</p>	<p>18</p>  <p>300*120 1 PCS</p>	<p>19</p>  <p>387*120 1 PCS</p>	<p>20</p>  <p>397*294 1 PCS</p>

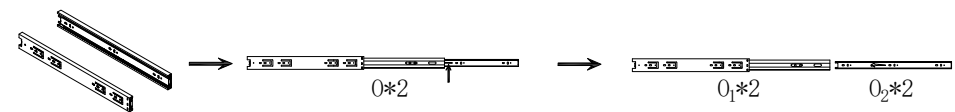
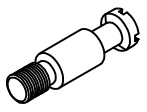
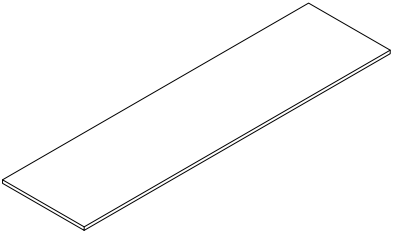
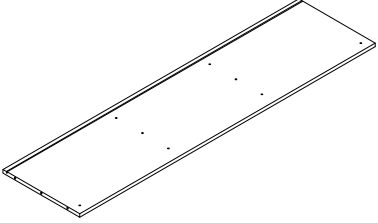
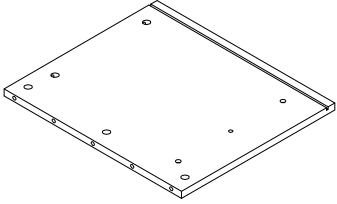
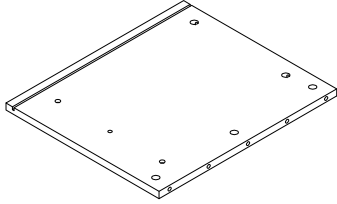
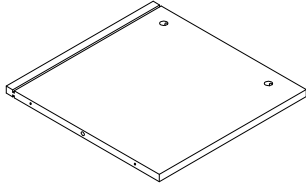
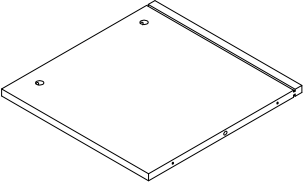
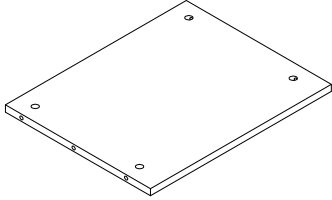
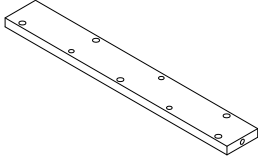
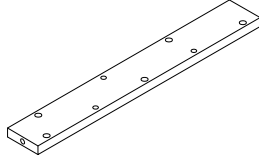
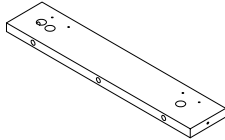
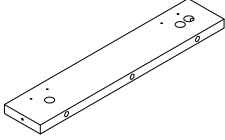
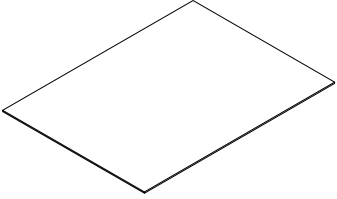
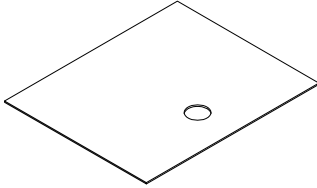
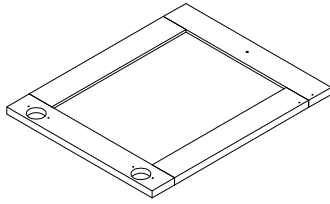
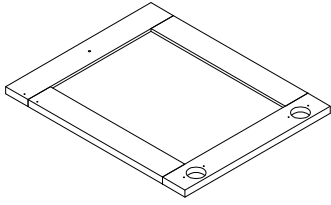
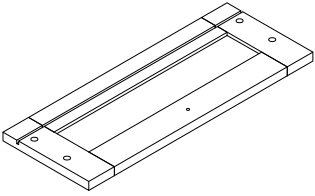
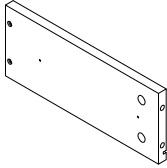
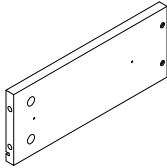
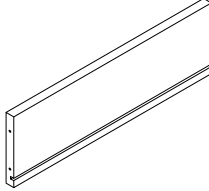
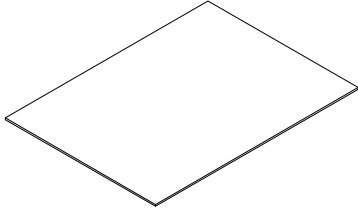

Hardware installation demonstration

NOTE: Please make sure "A" hardware tightened and can't be pulled out!

I

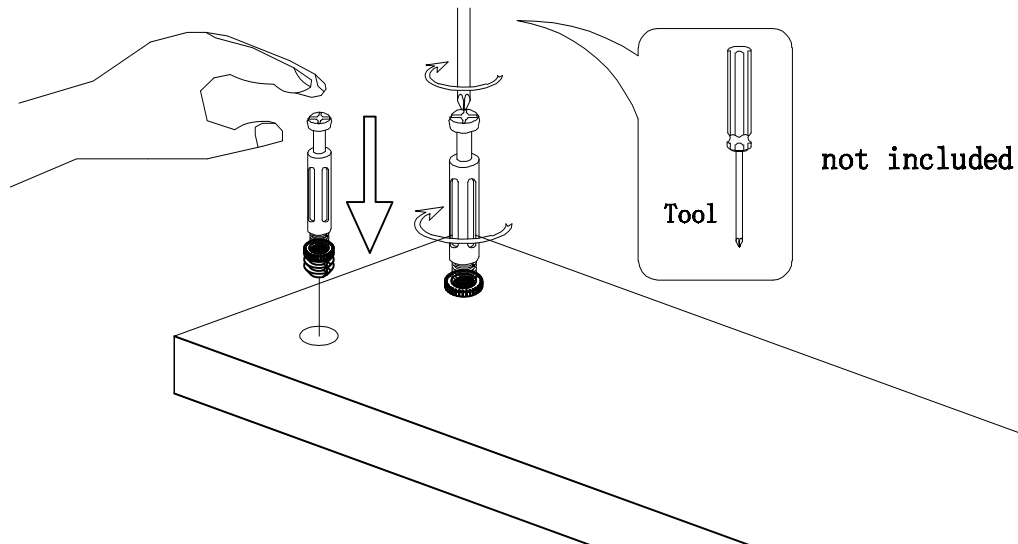

II

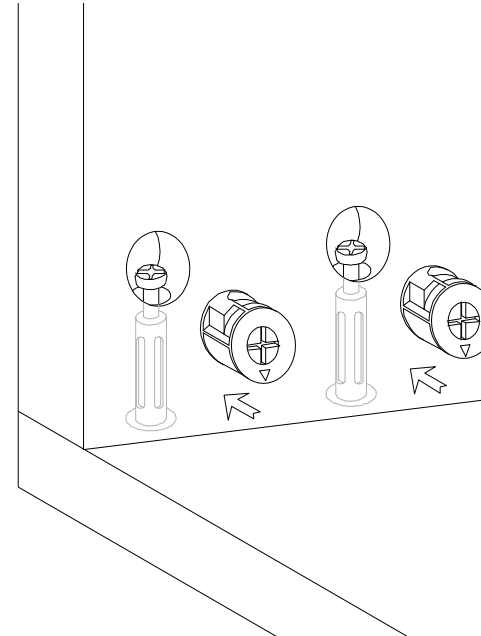

III

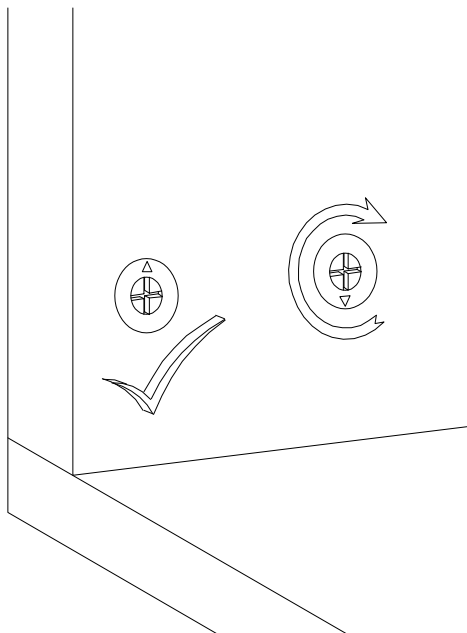







IV

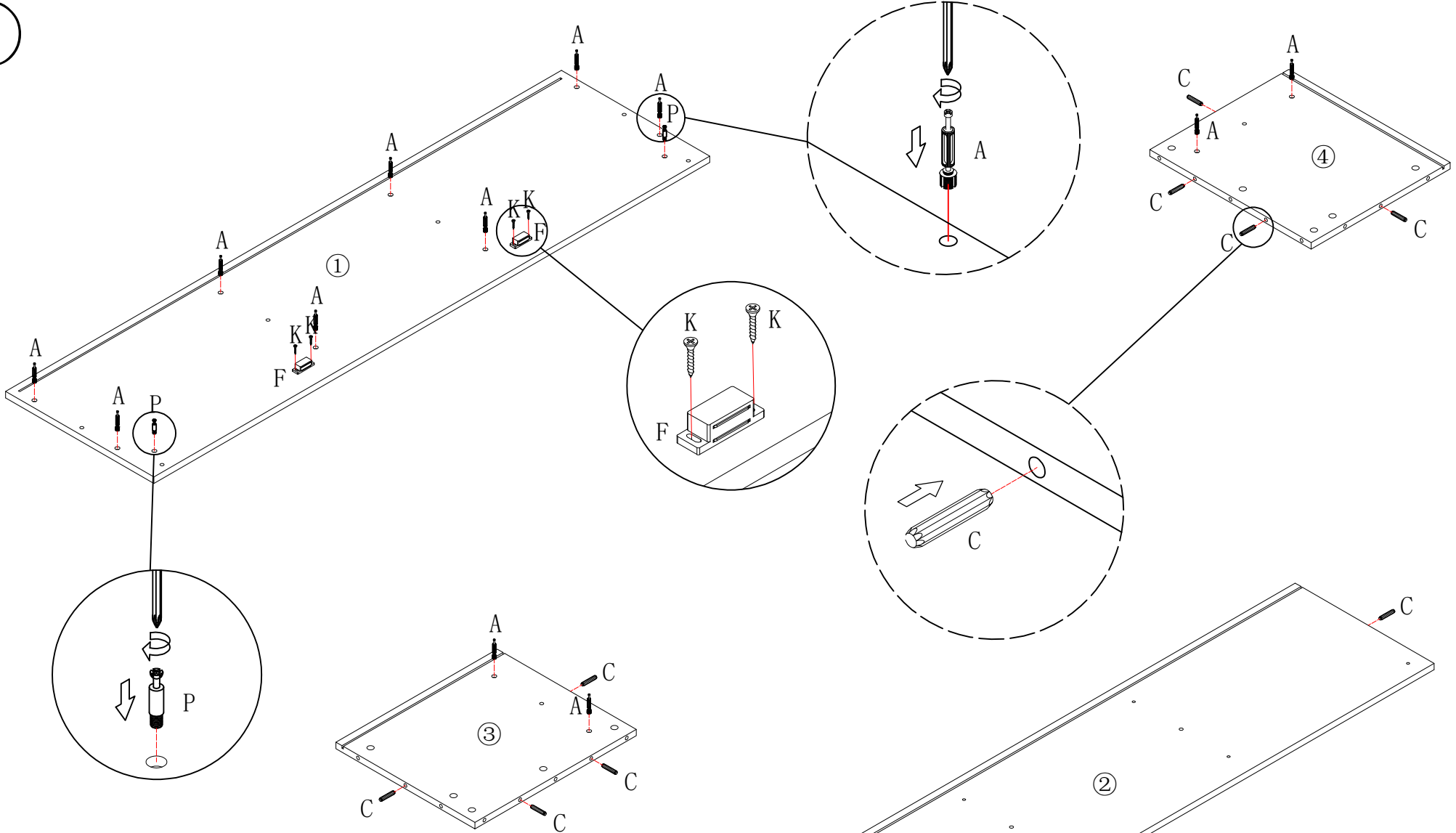

Scan QR code for assembly video

1







	A*12
	C*10
	F*2
	K*4
	P*2

put A on board ①③④

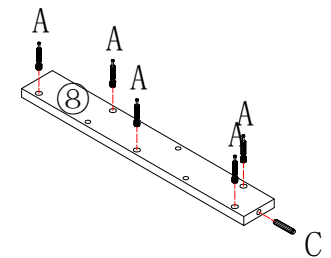
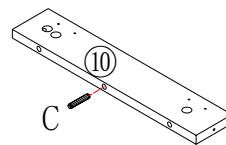
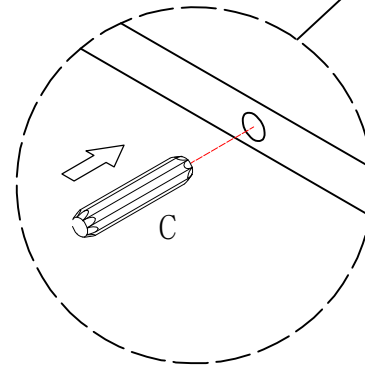
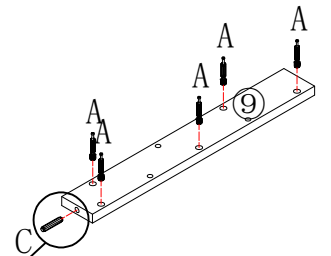
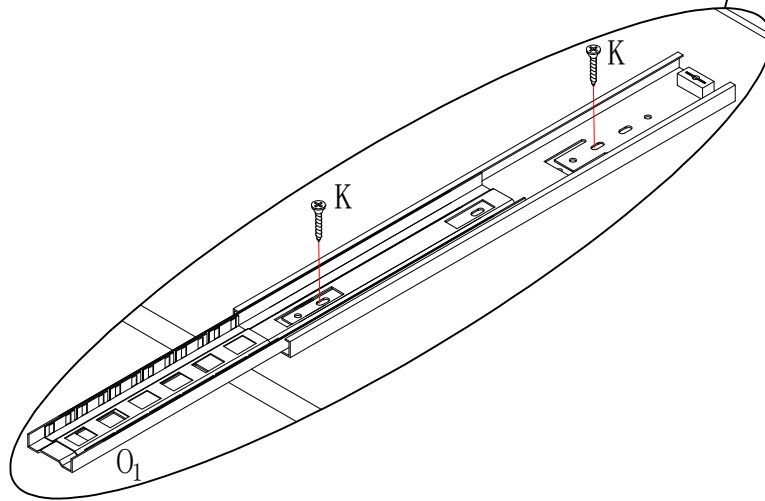
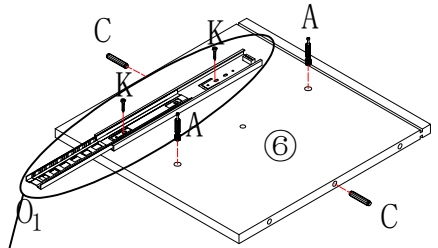
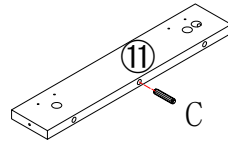
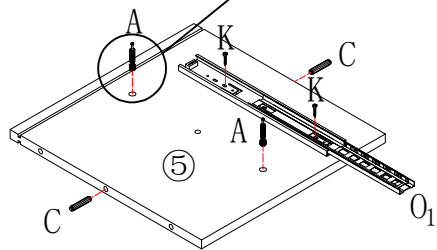
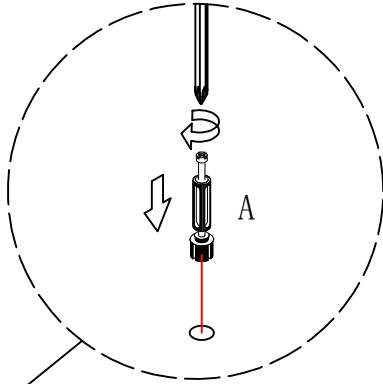
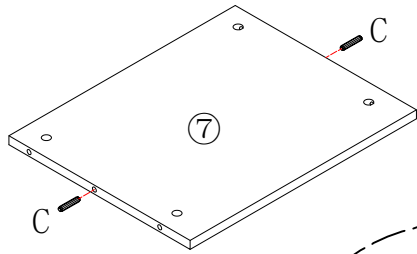
put C on board ②③④

②



	A*14
	C*10
	K*4
	O ₁ *2

put A on board ⑤⑥⑧⑨

put C on board ⑤⑥⑧⑨⑩⑪

3

Make sure the arrow on the screw align to the hole on the side.

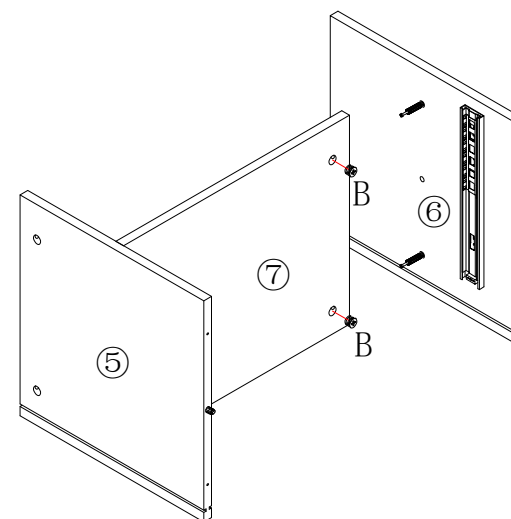
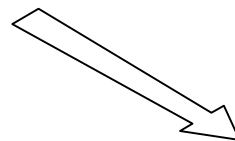
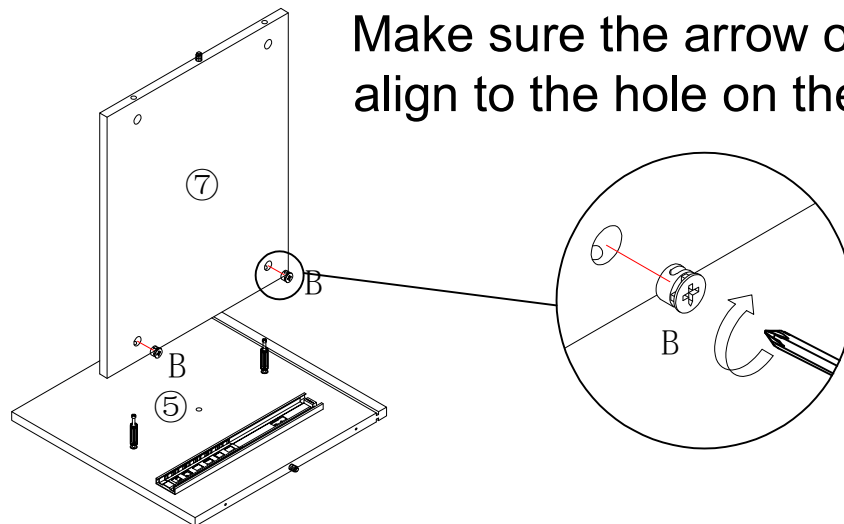



B*4

put B on board 7

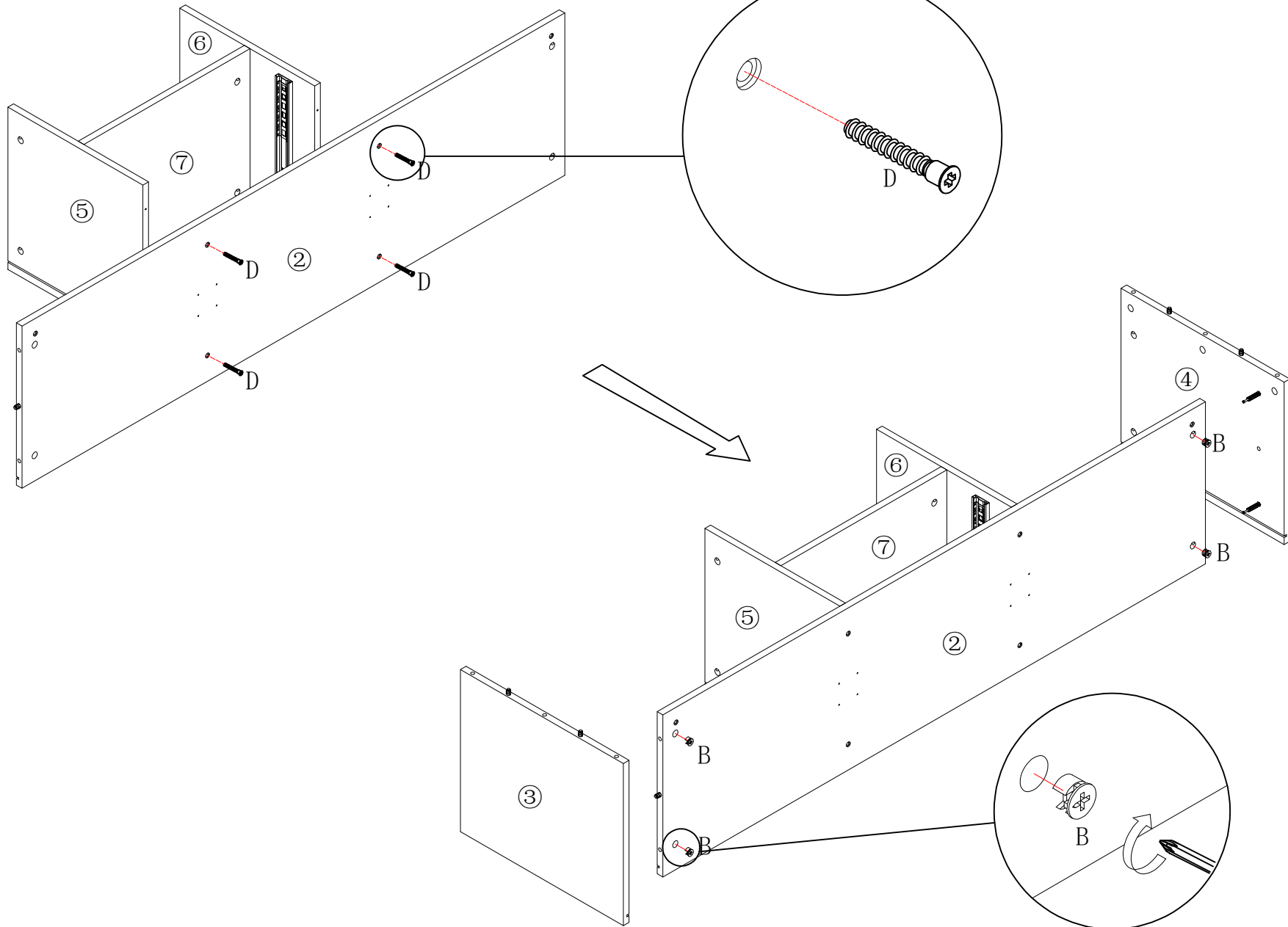
4



	B*4
	D*4

put B on board ②

Make sure the arrow on the screw align to the hole on the side.

5

Make sure the arrow on the screw align to the hole on the side.

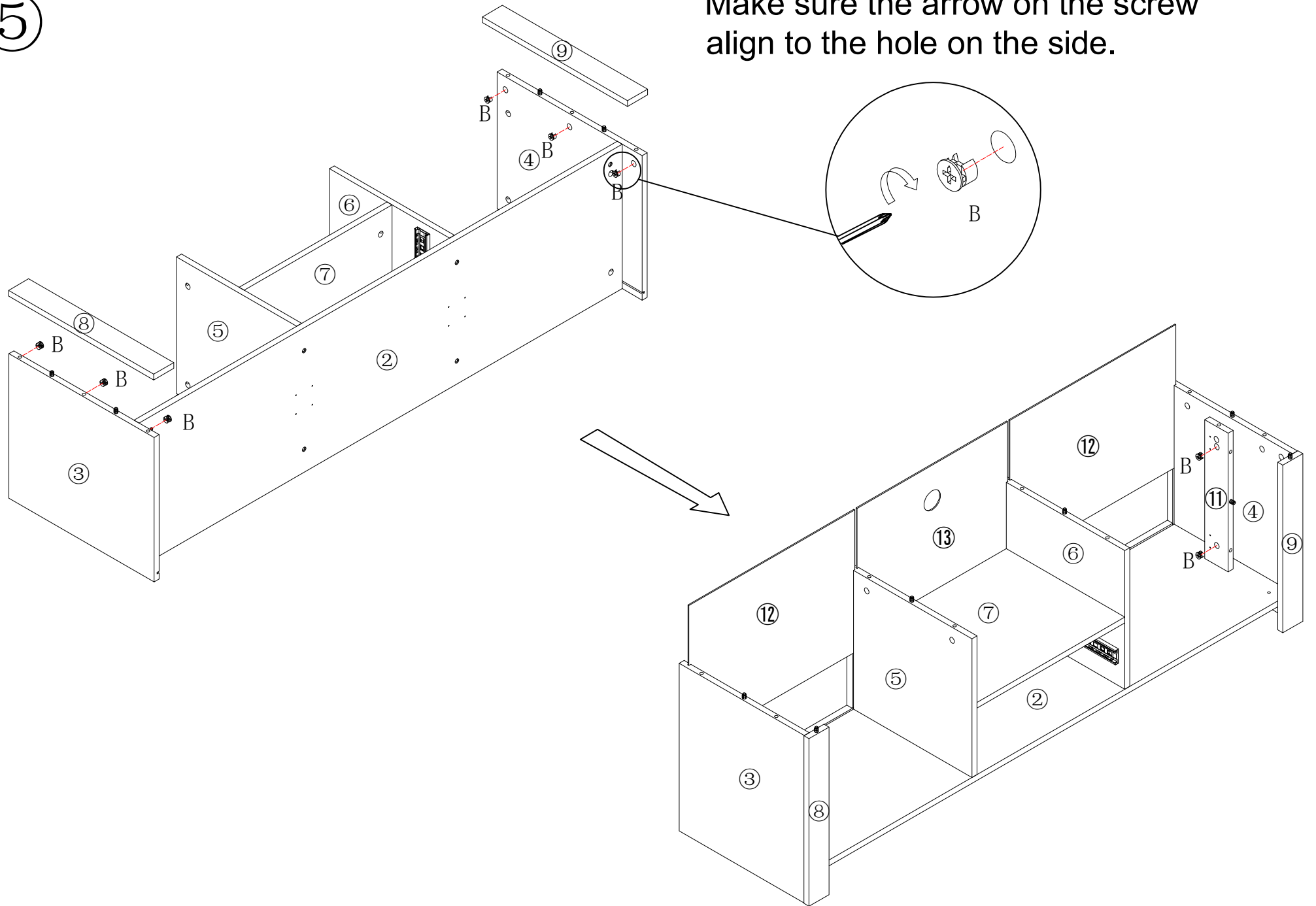

B*8

put B on board ③④⑪

6

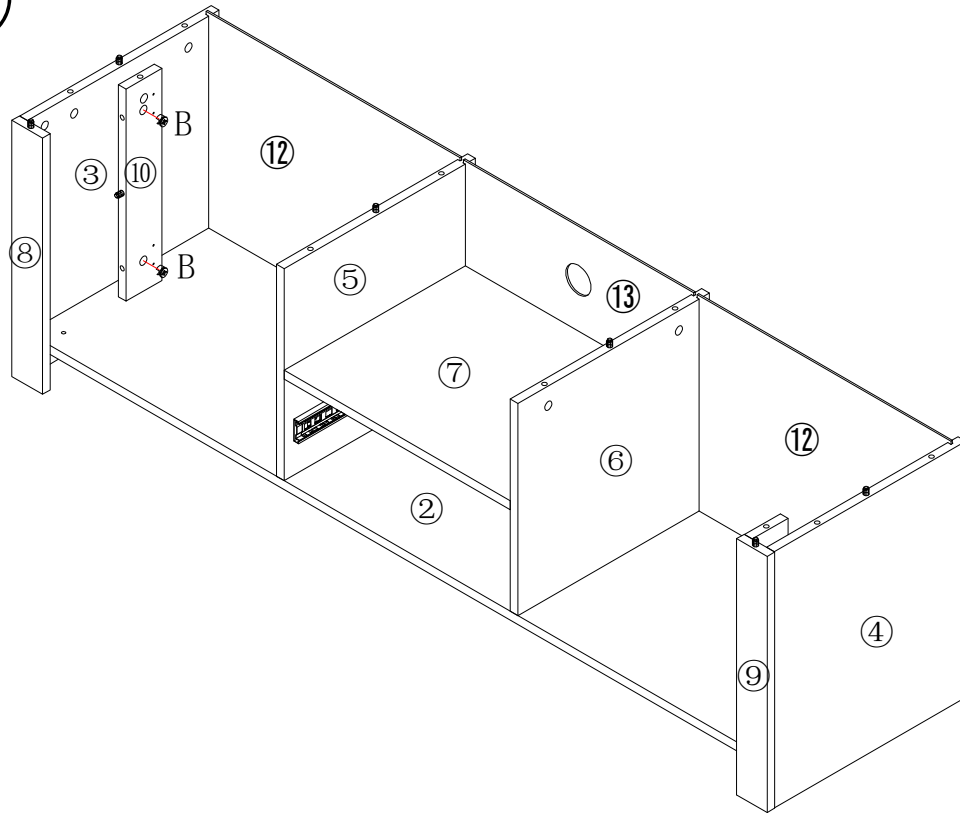

Make sure the arrow on the screw align to the hole on the side.

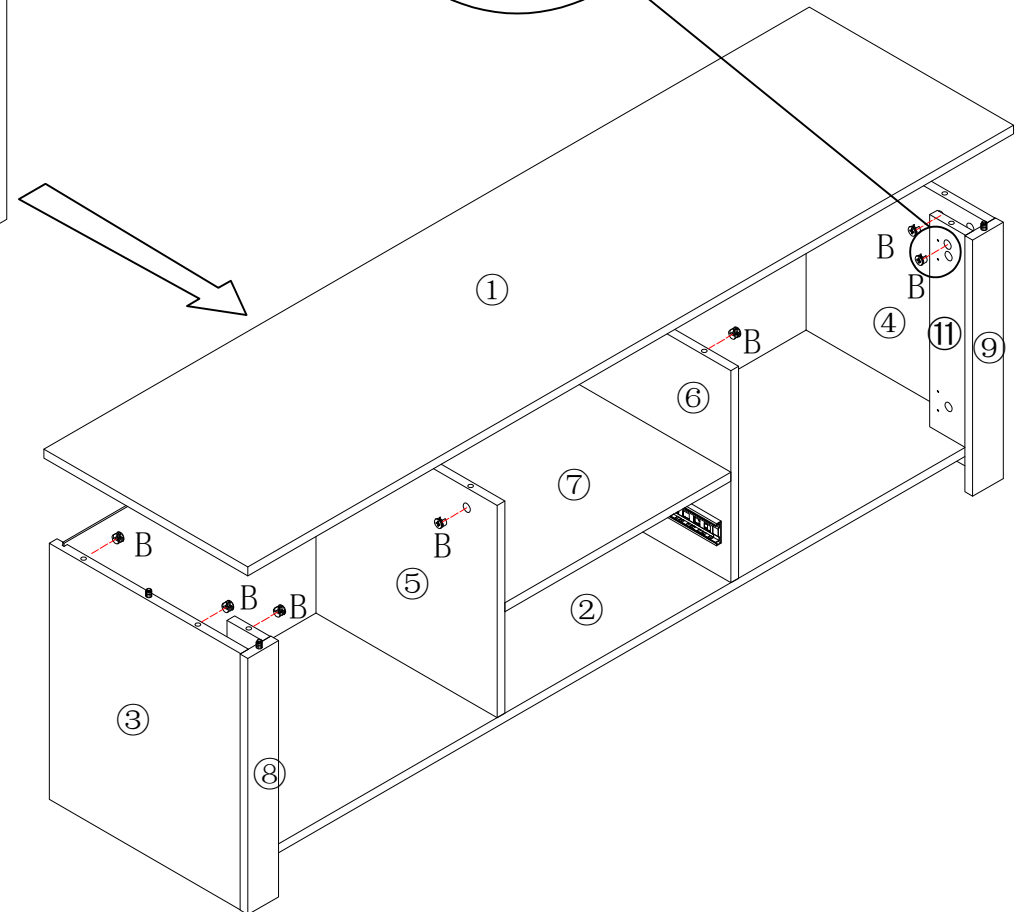
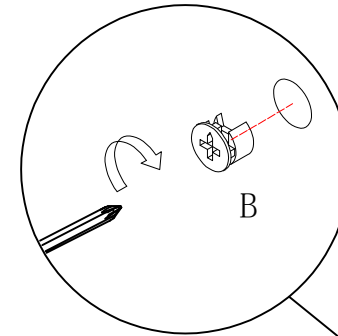

B*12 put B on board ③④⑤⑥⑩⑪

7

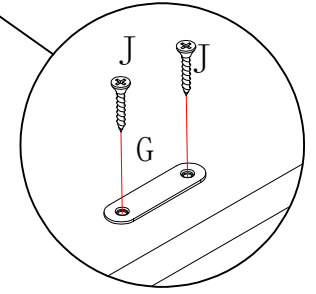
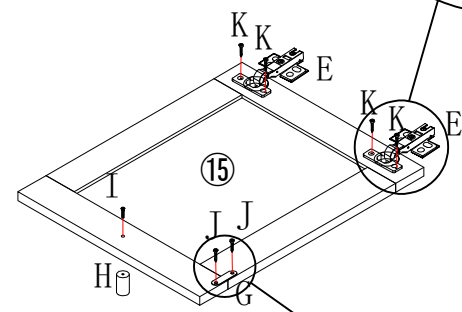
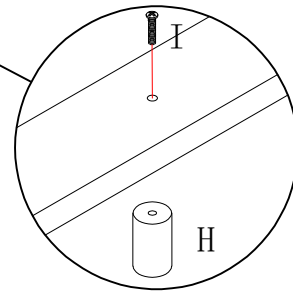
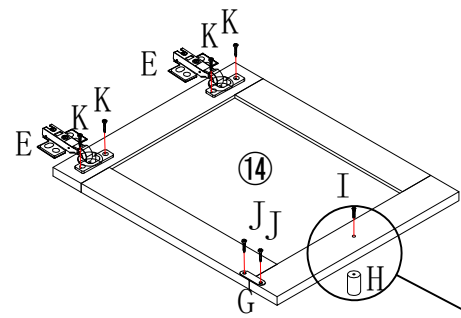
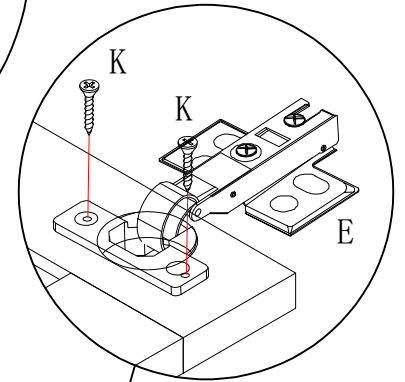
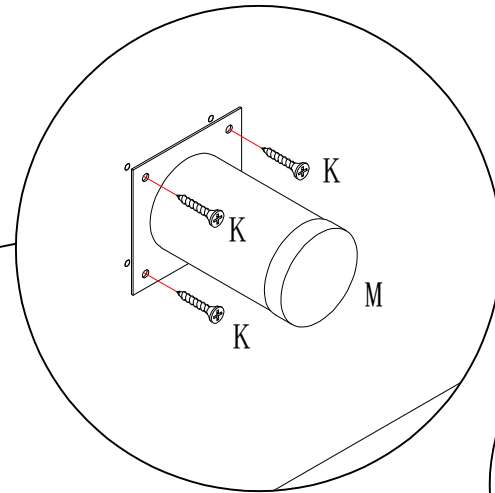
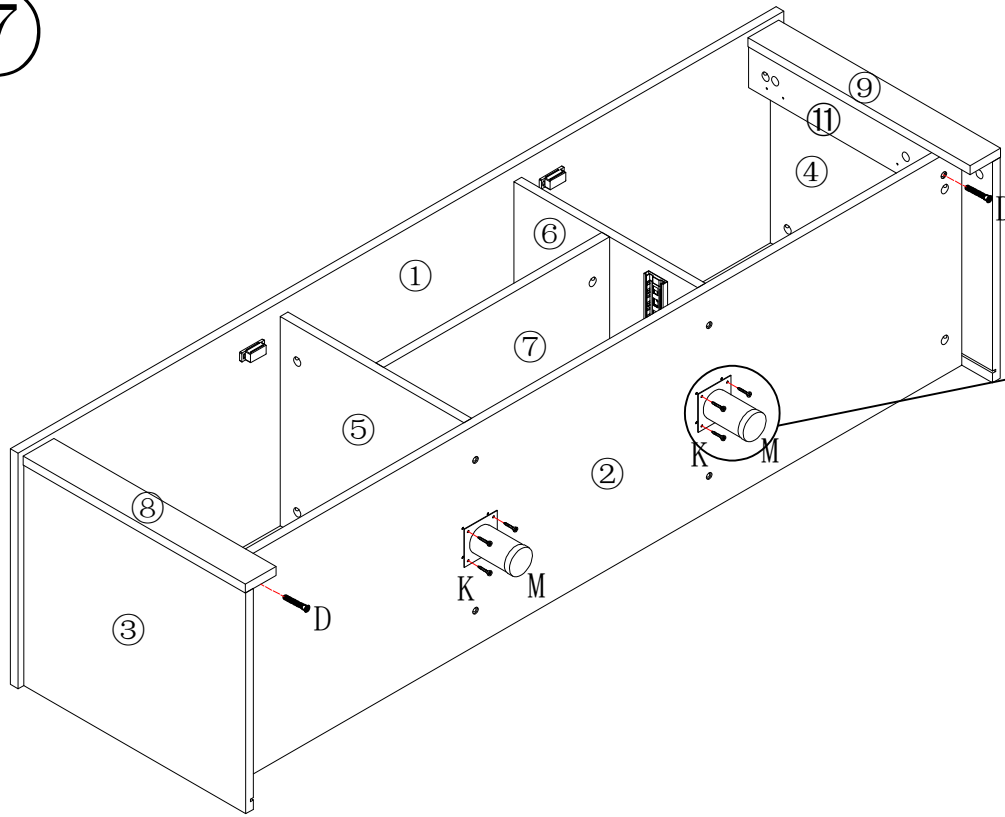

	D*2
	E*4
	G*2
	H*2
	I*2
	J*4
	K*16
	M*2

8

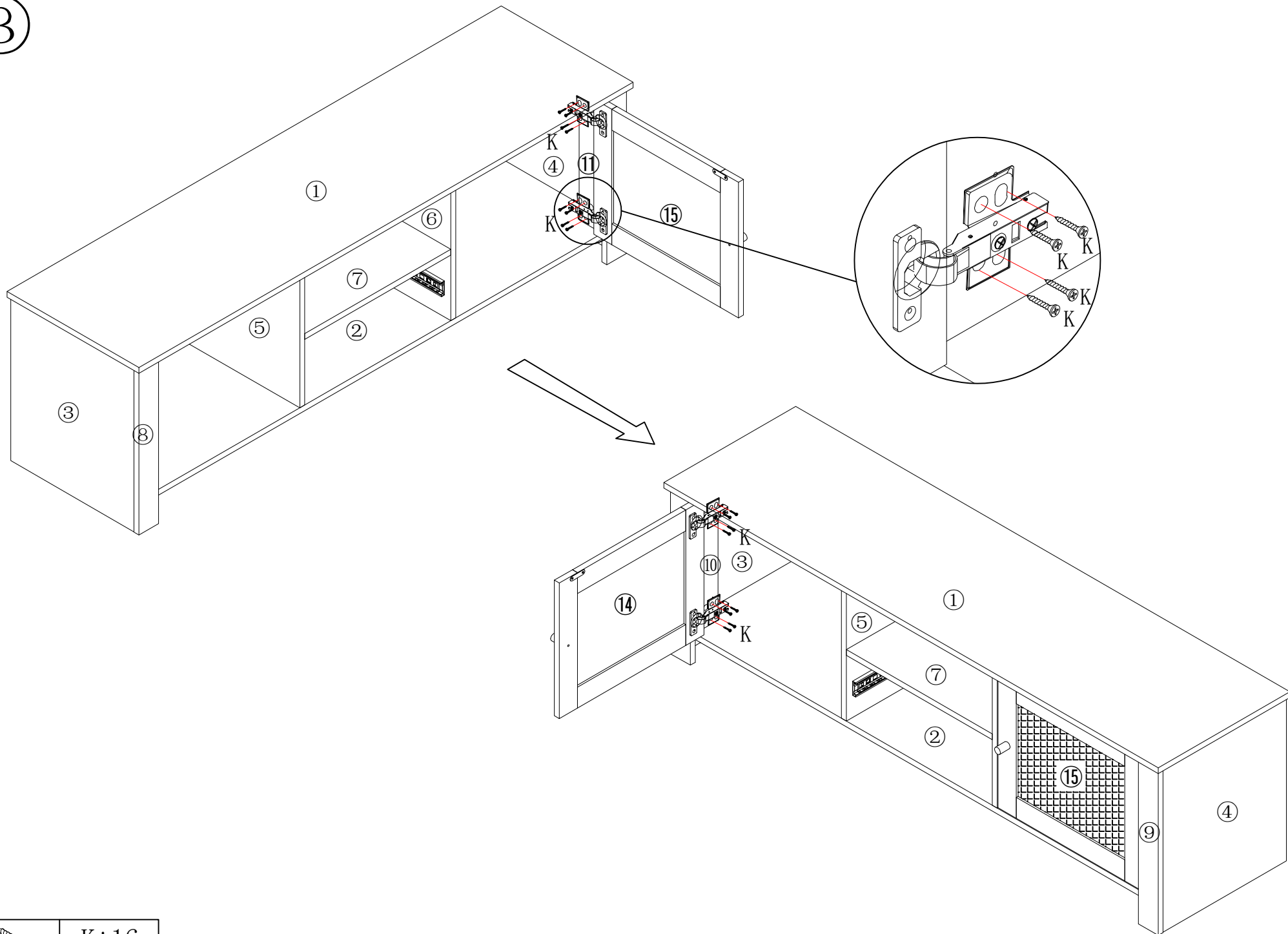





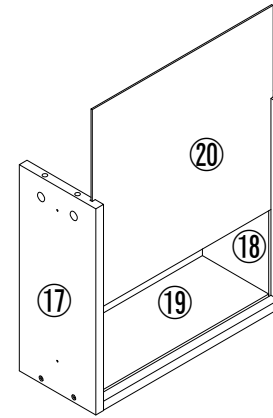
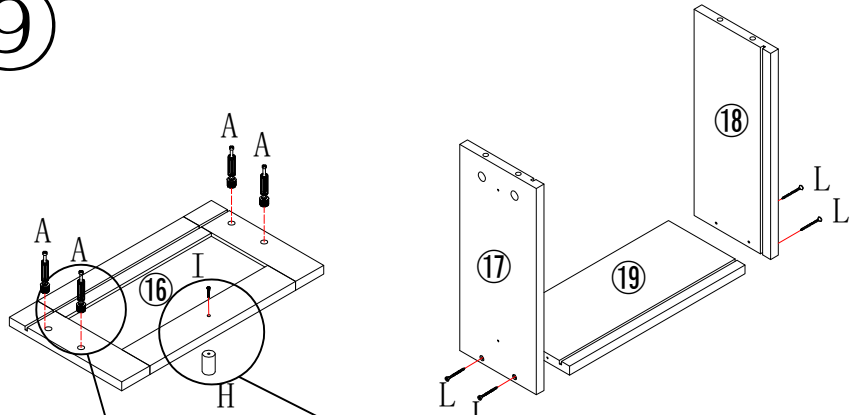

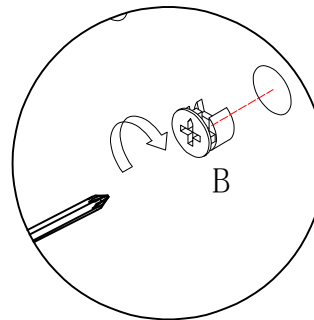
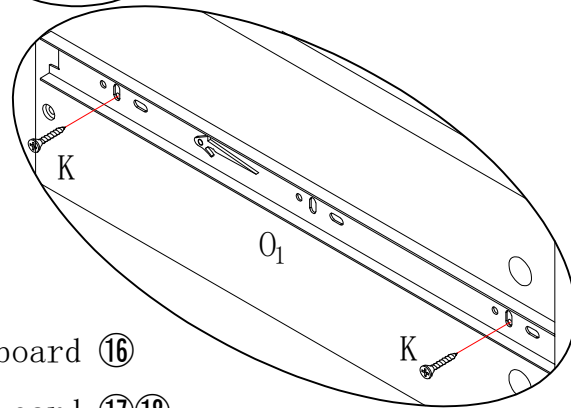
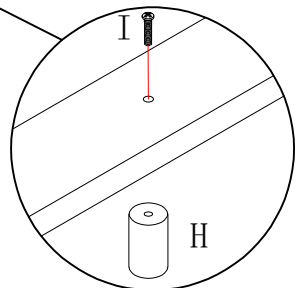
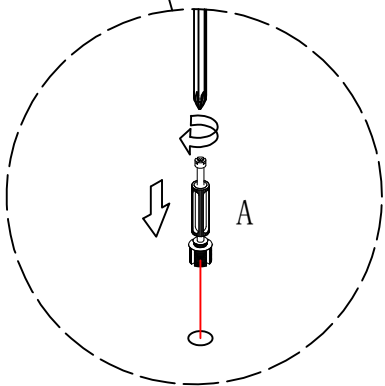
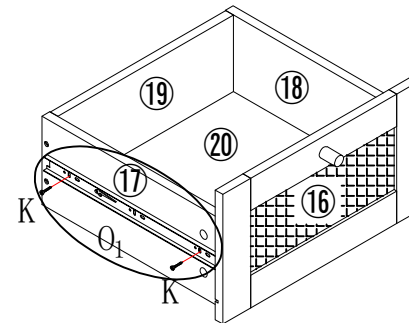
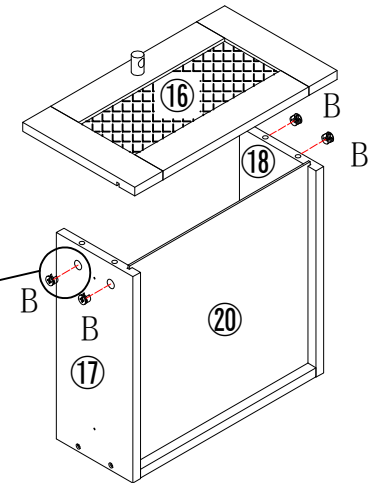

K*16

9



Make sure the arrow on the screw align to the hole on the side.





	A*4
	B*4
	H*1
	I*1
	K*4
	L*4
	O ₂ *2

put A on board 16

put B on board 17/18

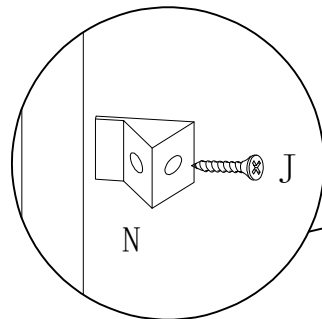
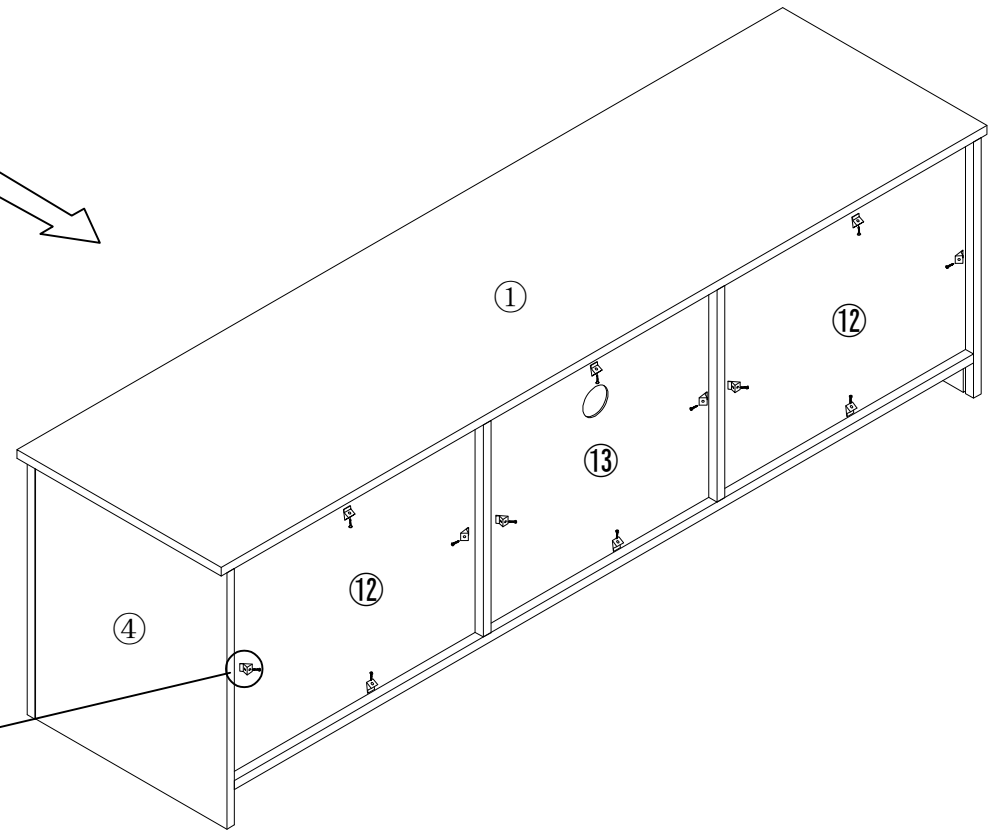
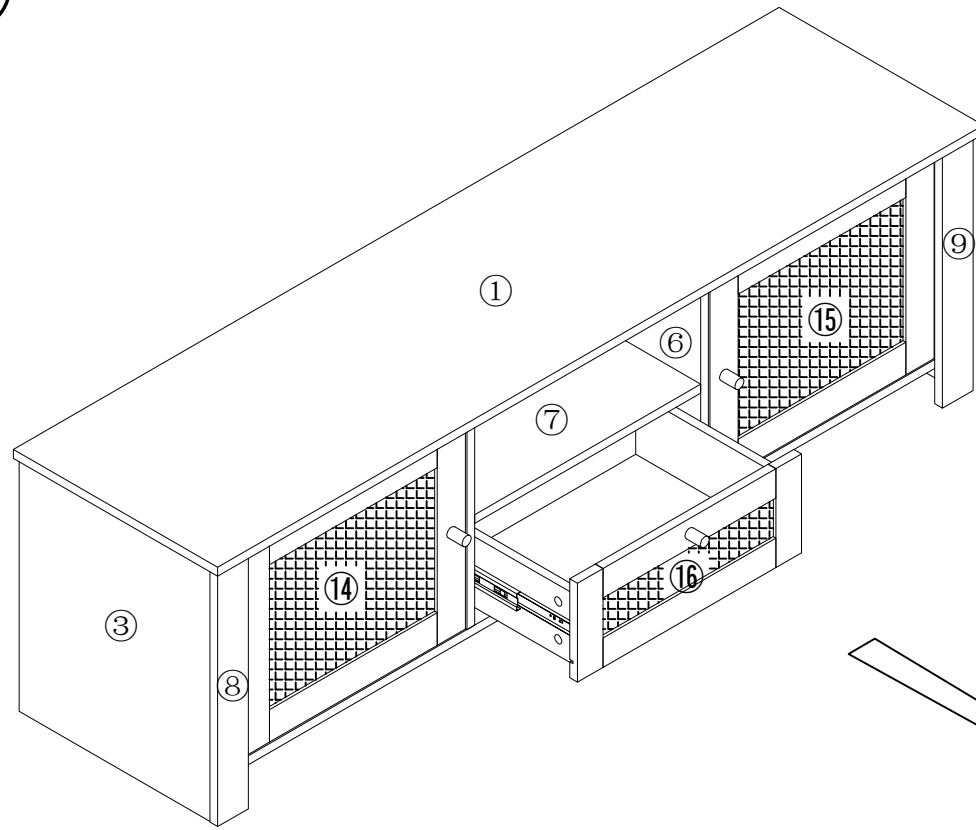
10



	J*12
	N*12

11

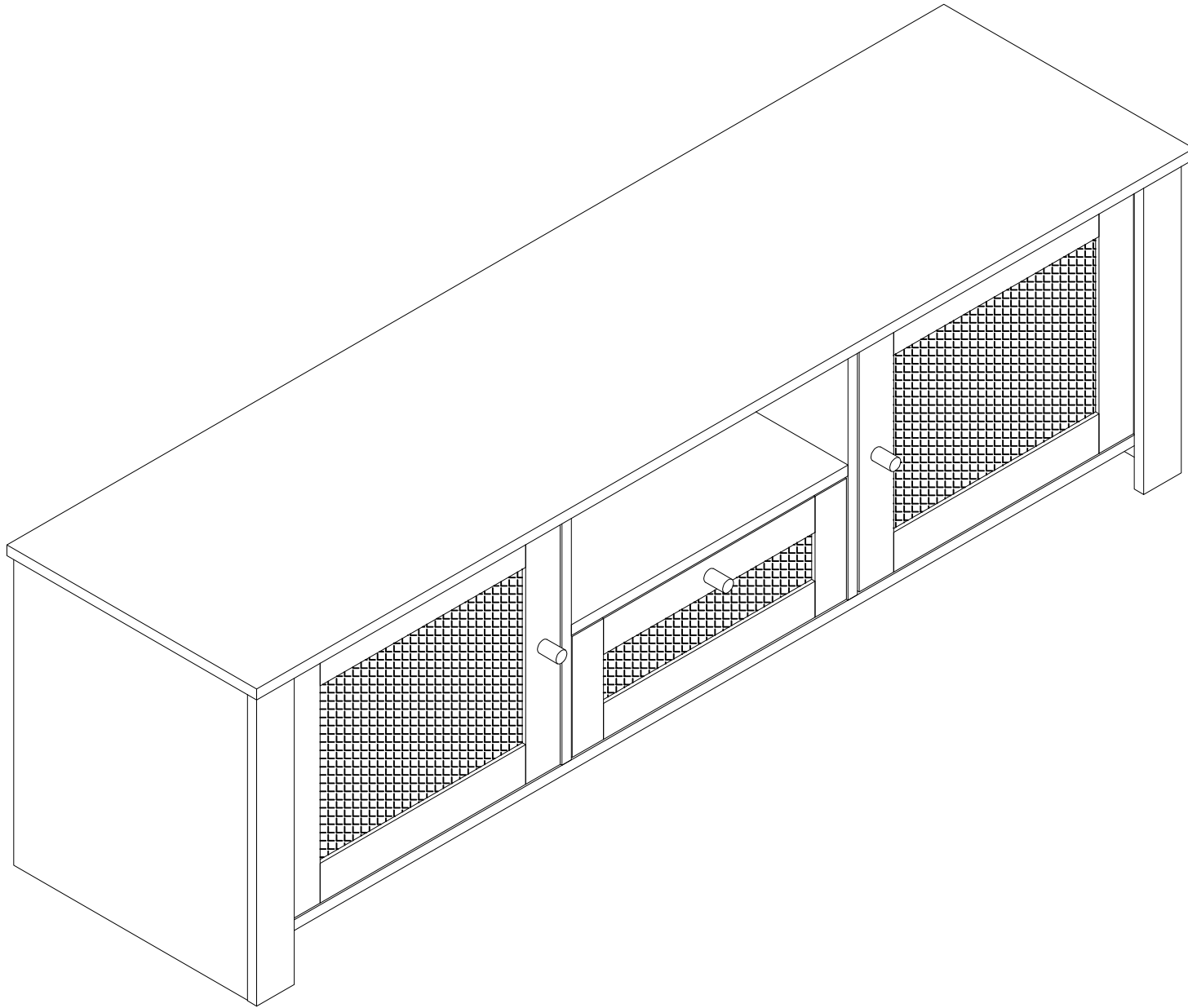

---END---