

# 60" ELECTRIC FIREPLACE ENTERTAINMENT CENTER WITH DOOR SENSOR

## ASSEMBLY, CARE & USE INSTRUCTIONS

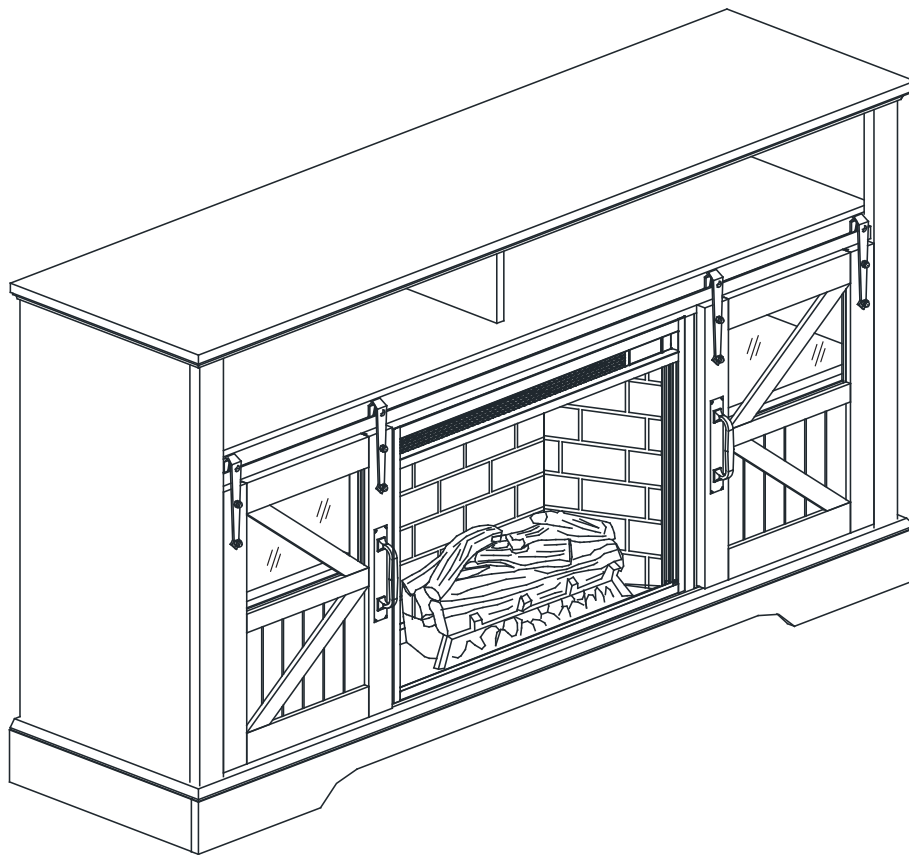

W102-2622L-JW Jasmine White

W102-2622L-DR Dark Rustic Oak

W102-2622L-RB Reclaimed Barnwood Color

---

## THANK YOU

We appreciate the trust to purchase our electric fireplace media mantel. We strive to continually create quality products designed to enhance your home. Visit us online to see our full line of products available for your home improvement needs. Thank you for choosing us!

## ASSEMBLY TIPS

---

Before you begin, locate the instructions and hardware. Take out all the parts and compare them to the diagrams below. Be sure you have all the parts and can identify them.

Two people are required to assemble this product. Assembly time will take approximately 30-90 minutes.

Before assembly, use scissors to unwrap the parts from the packaging. DO NOT use a box cutter or exacto-knife as you may cut into the mantel pieces inside the box and damage the finish. Check for the hardware bag which is RED and located inside the packaging, taped to the top box.

DO NOT discard any pieces.

## CAUTION

---

There are small components used in the construction of this product. Loose items should be kept away from pets and children to avoid a choking hazard. Keep all plastic and packaging film away from pets and children to avoid suffocation.

## CARE AND MAINTENANCE

---

1. Dust your fireplace mantel regularly with a soft non-lint producing cloth or household dusting product.
2. You can clean your fireplace insert with a gentle non-abrasive household cleaner. Make sure to dry your fireplace immediately with a soft cloth or towel.

## TOOLS REQUIRED ( NOT INCLUDED)

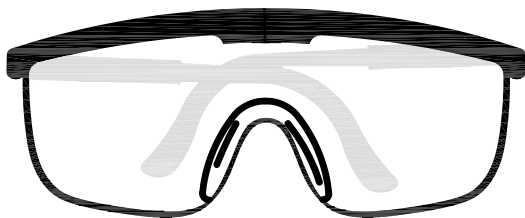

Safety goggles

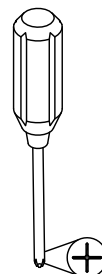







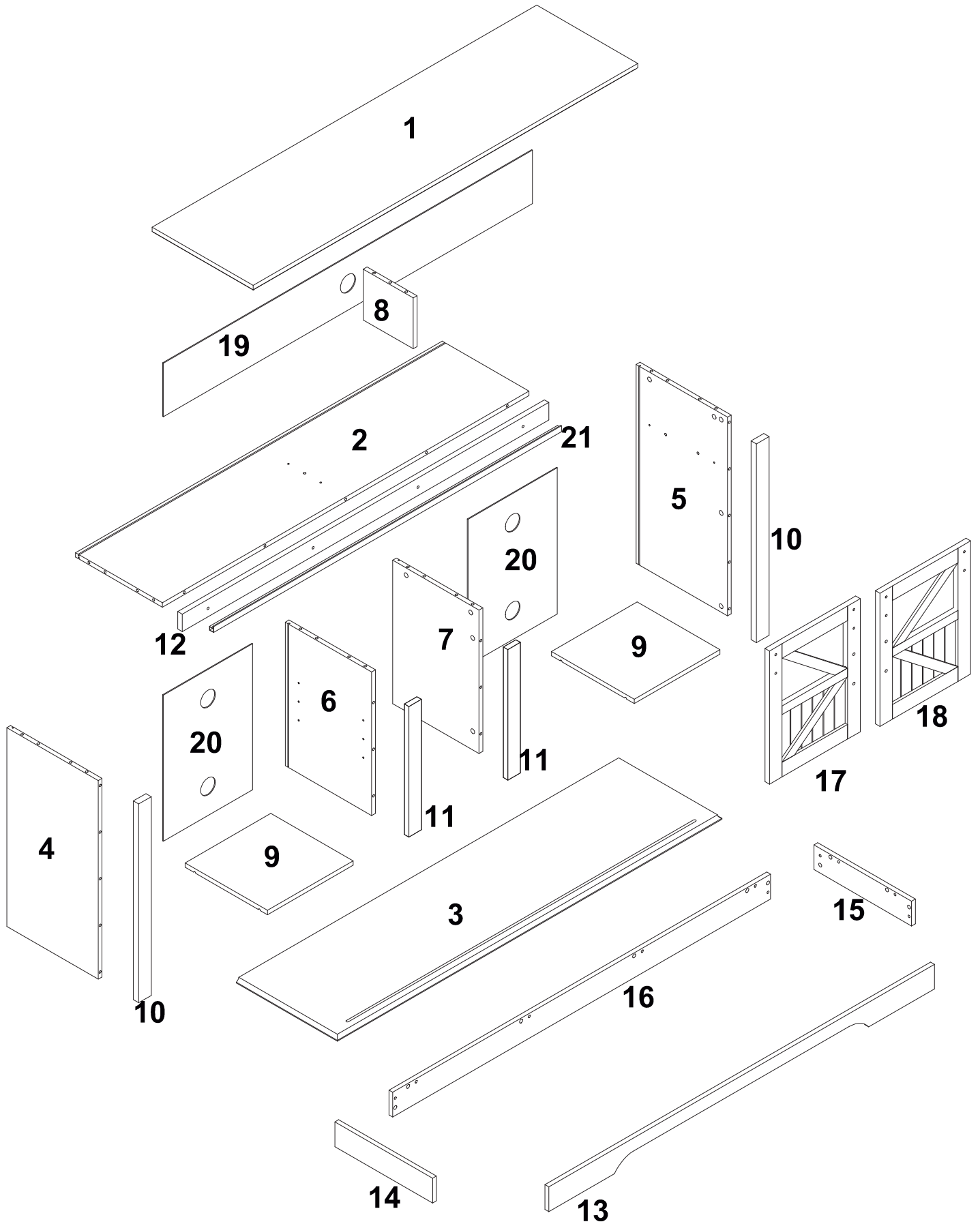



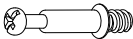



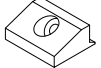

Phillips screwdriver

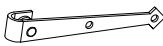
Questions, problems, missing parts? Before returning to your retailer, send email to this mail box at any time: [service@cambridgeelectrical.cn](mailto:service@cambridgeelectrical.cn)

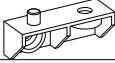
# PACKAGE CONTENTS

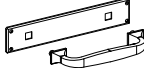

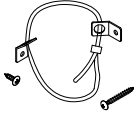
# Hardware List

A		Ø8x30mm	Wood dowel	31+1 pcs
B		Ø6x35mm	Cam bolt	30+1 pcs
C		Ø15x11mm	Cam lock	30+1 pcs
D			Sticker	30+1 pcs
E			Plate	4 pcs
F		Ø8x5x16mm	Shelf support pin	8 pcs
G		1/4x12mm	Bolt	32+1 pcs
H			Plastic wedge	16 pcs
I		Ø3x17mm	Flat-head screw	16 pcs
J		M 4	Hex key	1 pcs
K			Pulley	4 pcs
L			Nut	8 pcs
M		1/4x25mm	Bolt	12 pcs
N			Connector	16 pcs
O			Wrench	1 pcs
P		Ø4x16mm	Handle bolt	4 pcs
Q			Handle	2 Set
R		Ø4x12mm	Screw	12 pcs
S		Ø6x50mm	Screw	8 pcs
T			Anti-Tipping Device	2 set
U			Nut	2 pcs

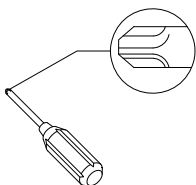

Philips head screwdriver required for assembly  
(not included)

# Step 1

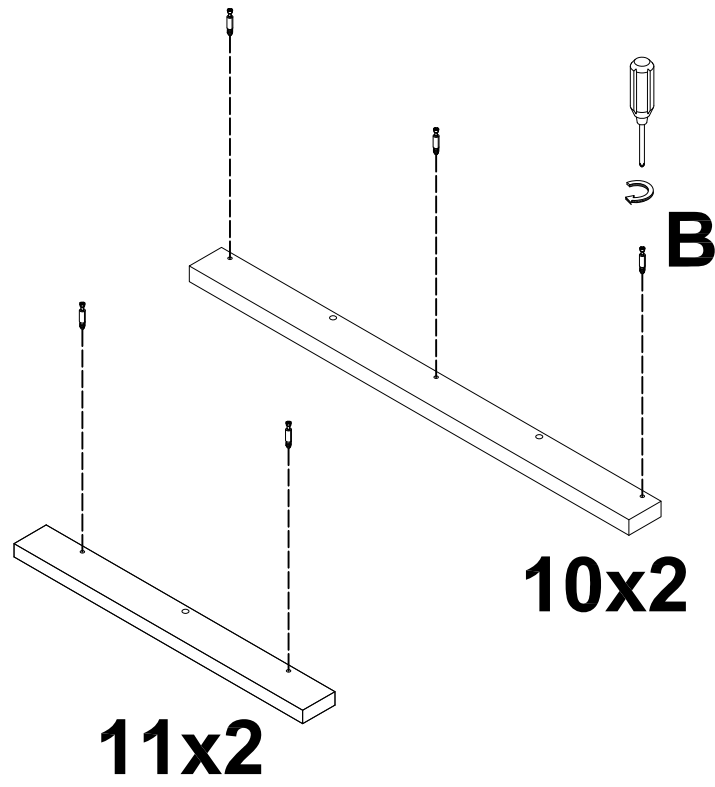
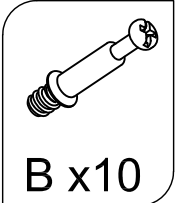

# Step 2

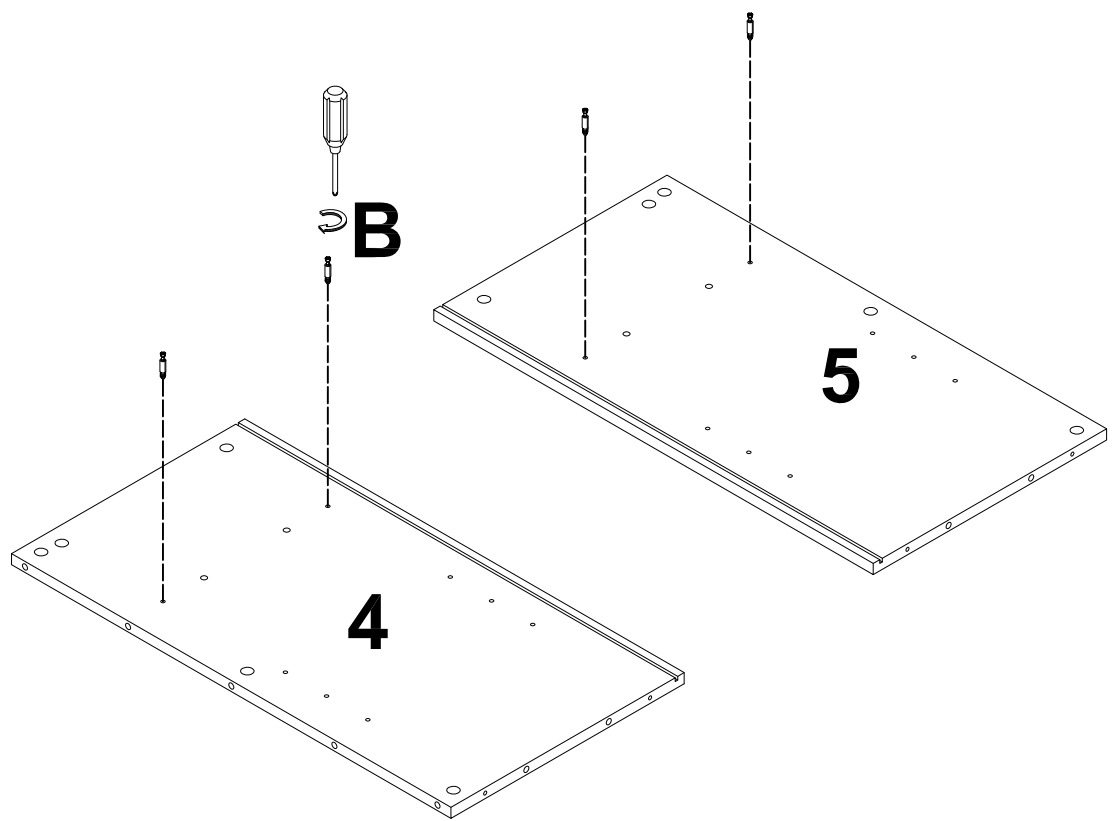
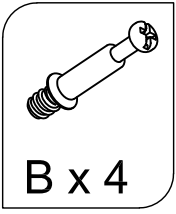

# Step 3

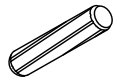
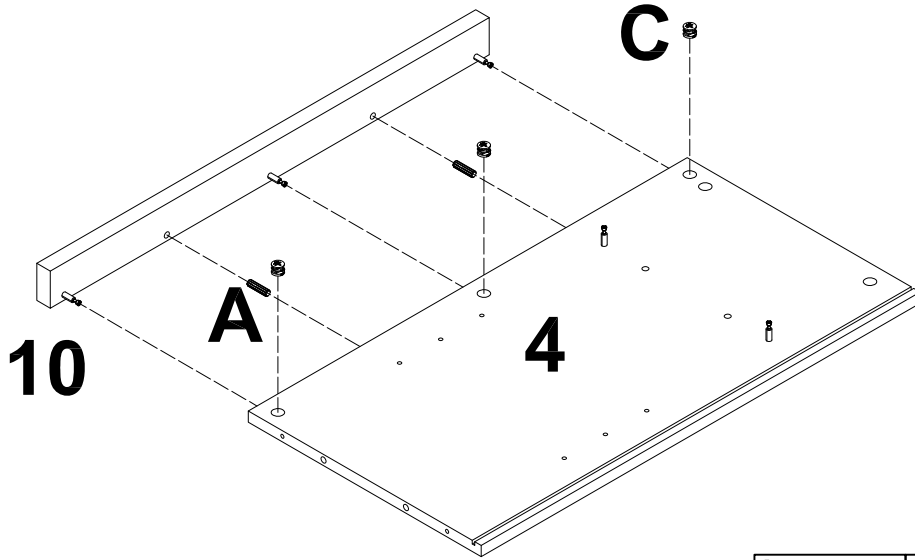

A x 2



C x 3

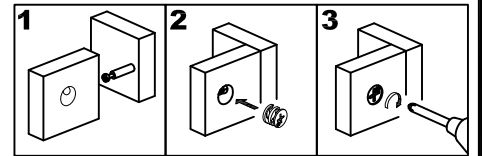

# Step 4

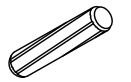
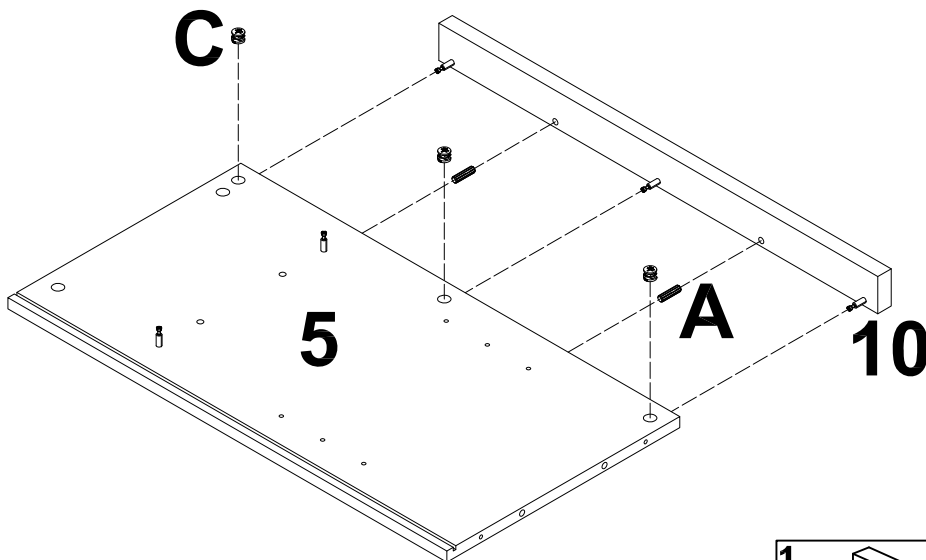

A x 2



C x 3

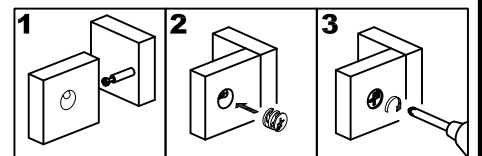

# Step 5

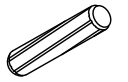

A x 1



C x 2

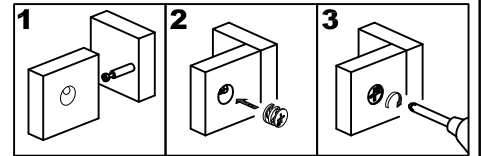
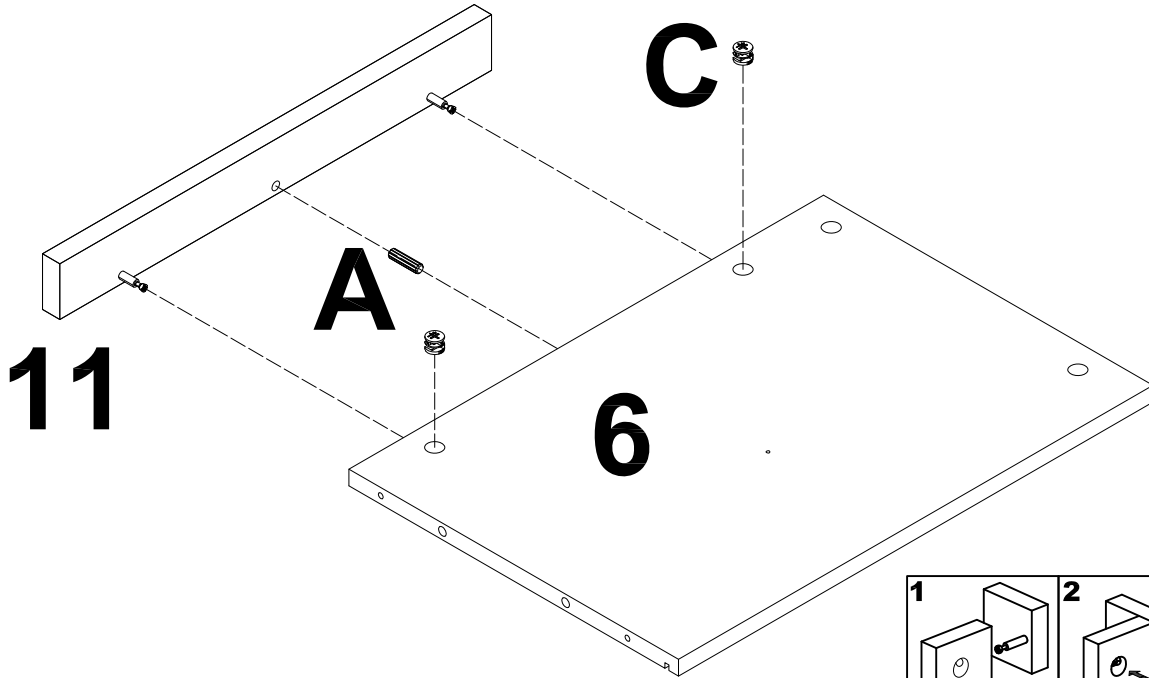

# Step 6

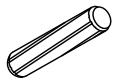

A x 1



C x 2

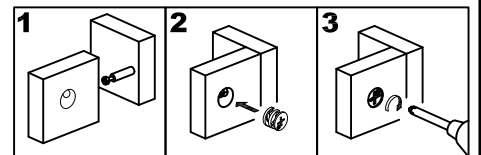
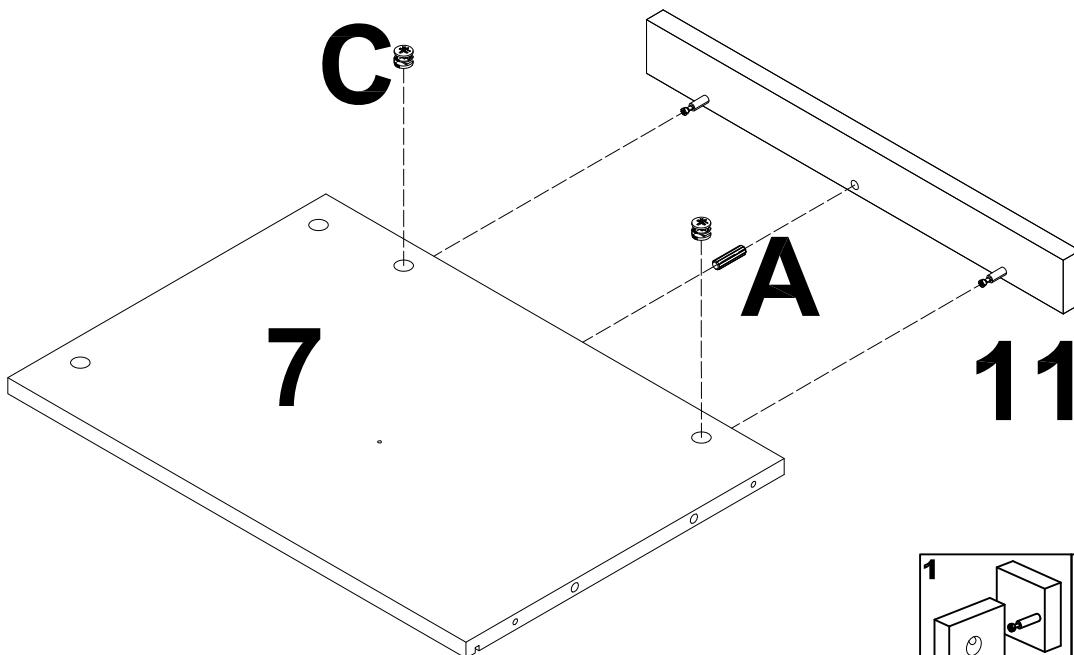

# Step 7

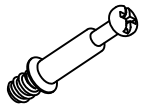
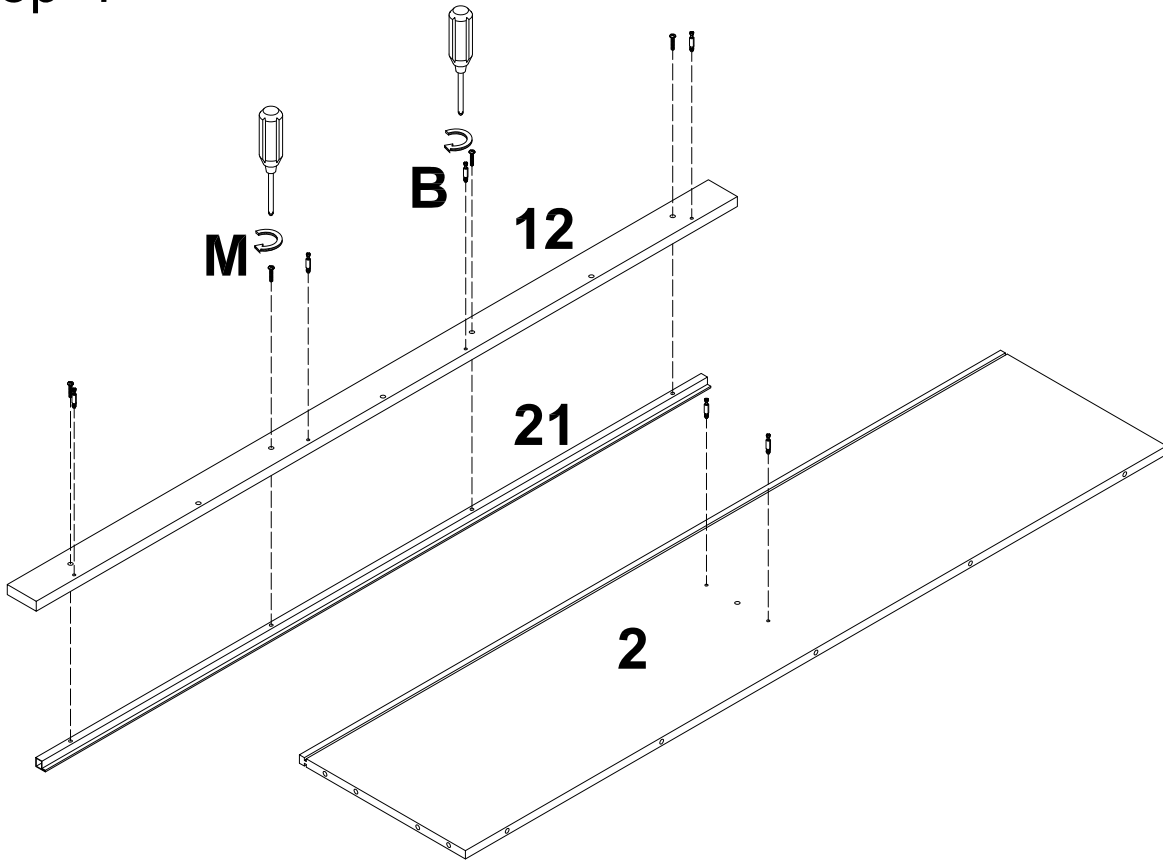

B x 6

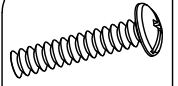

M x 4

# Step 8

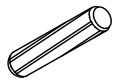
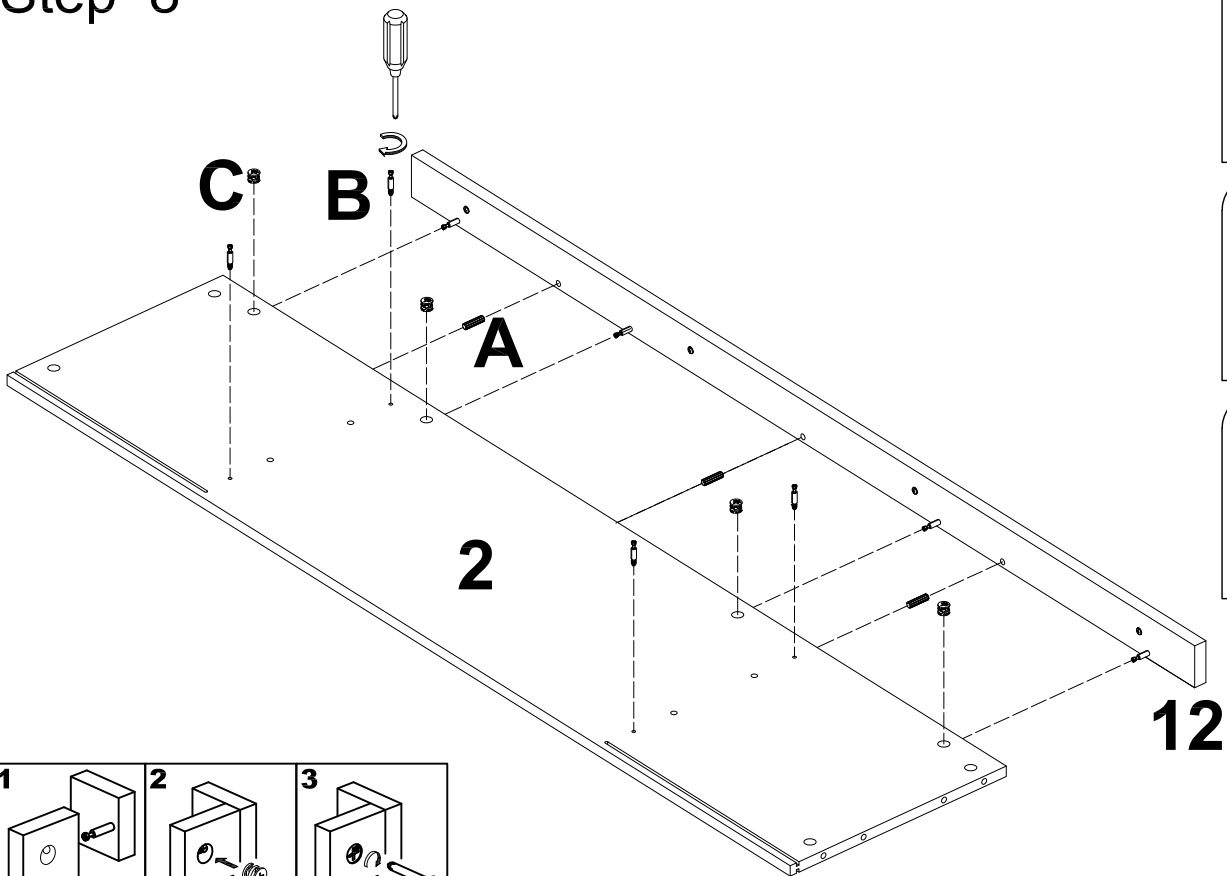

A x 3

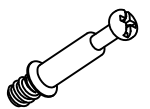

B x 4



C x 4

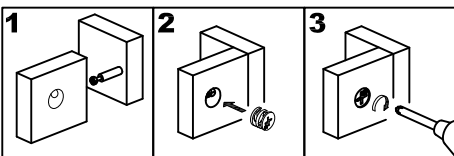



# Step 9

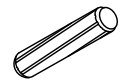
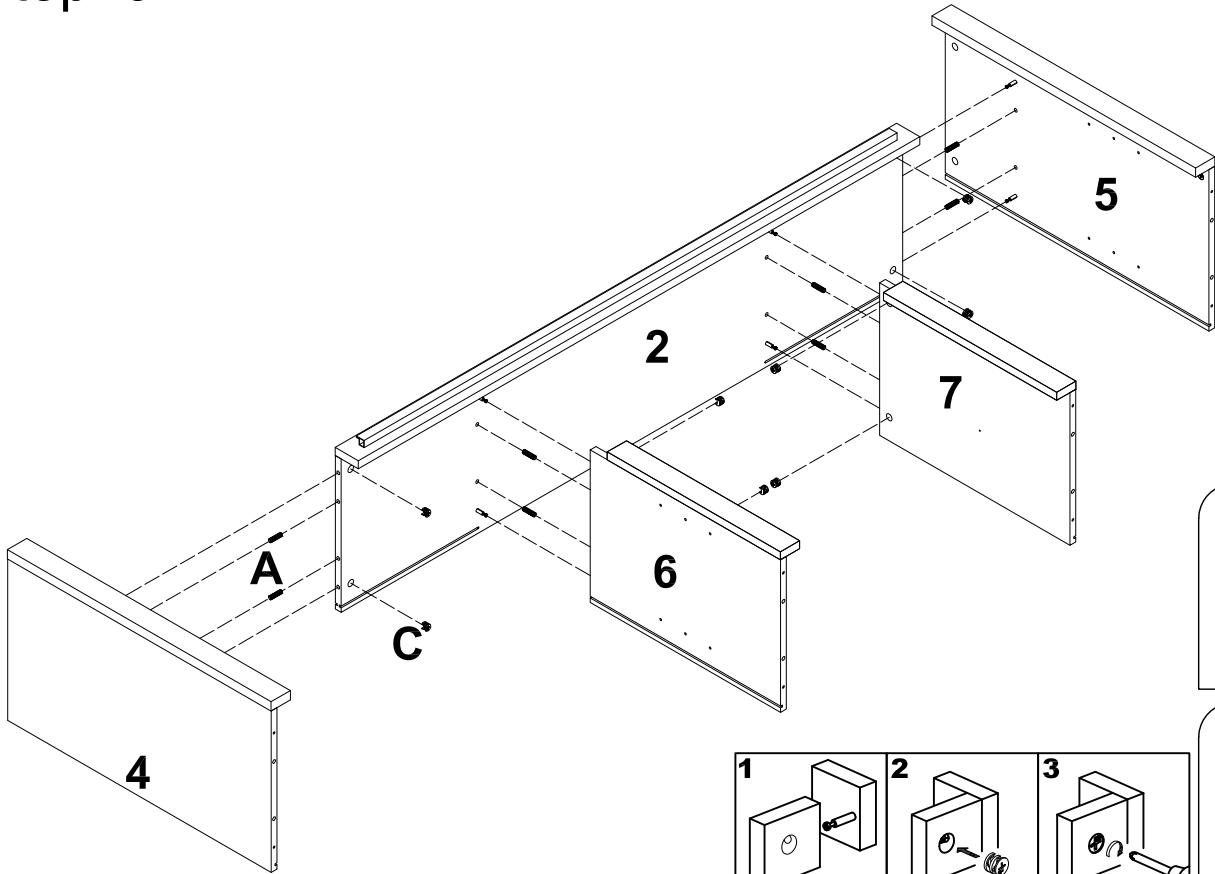

A x 8



C x 8

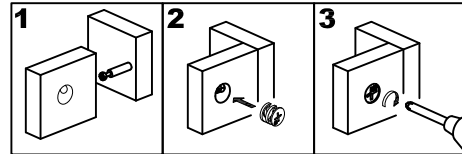

# Step 10

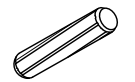
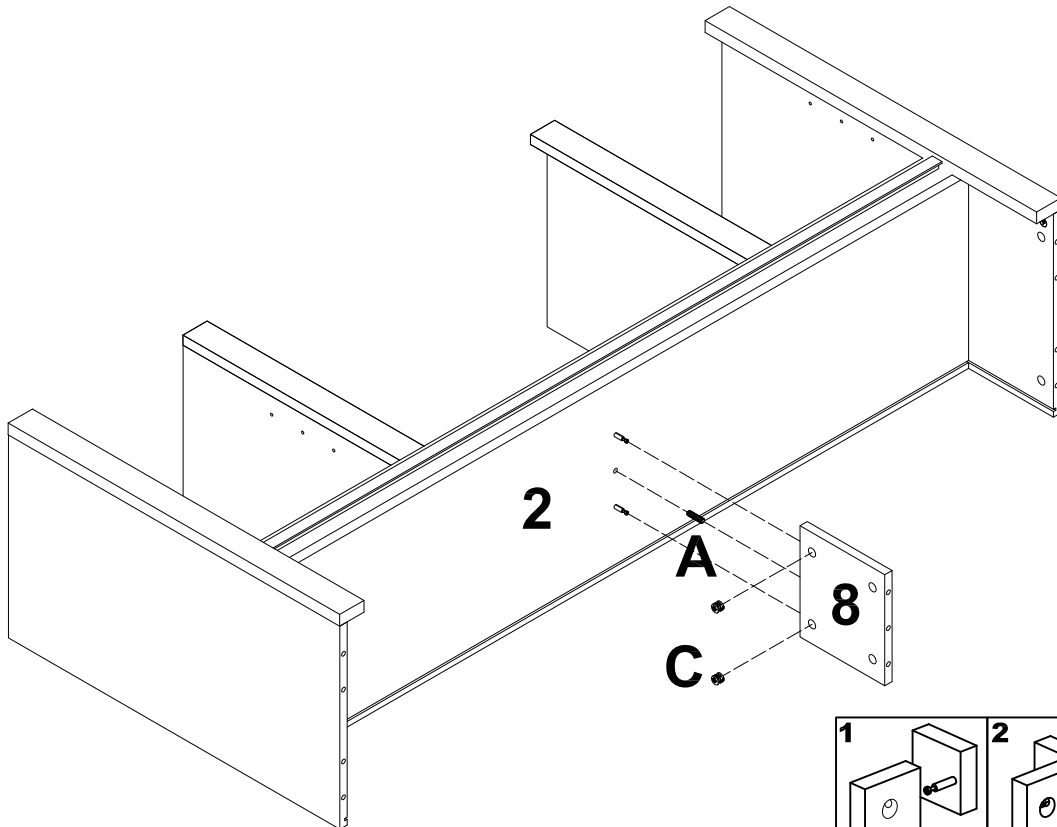

A x 1



C x 2

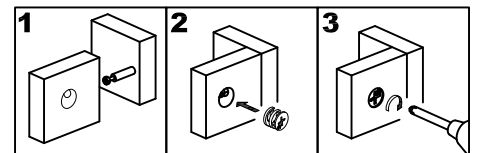

# Step 11

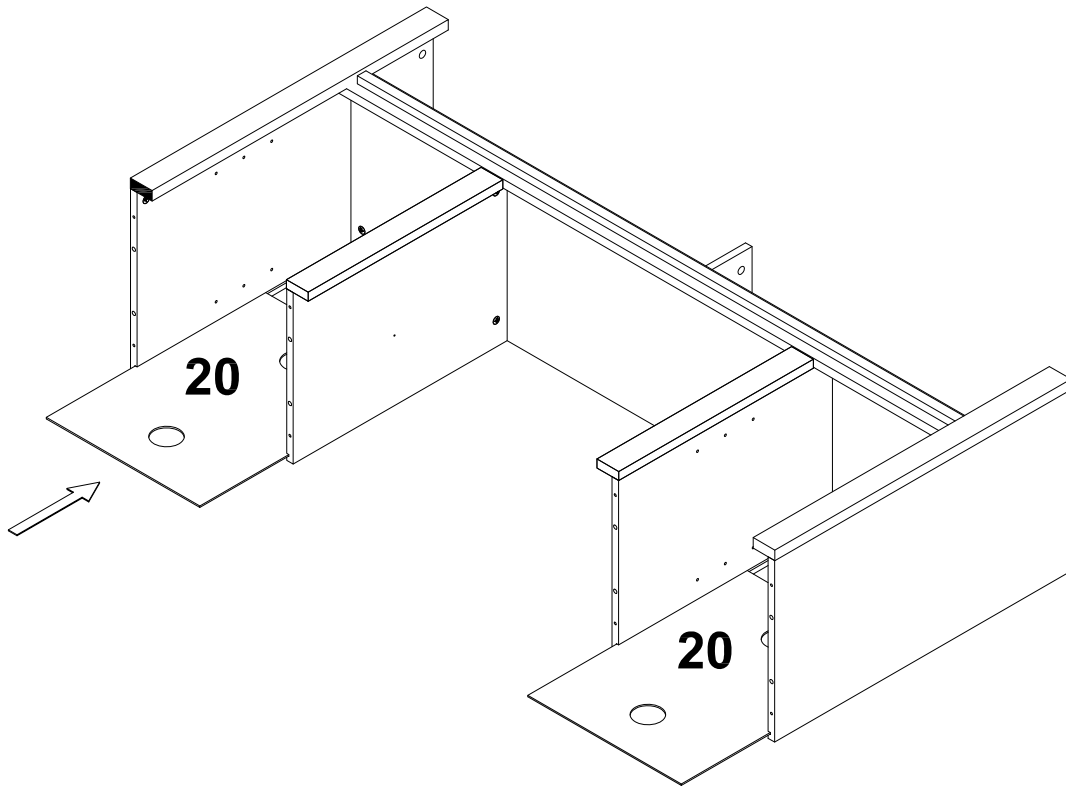

# Step 12

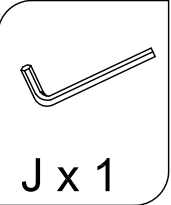
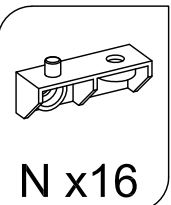
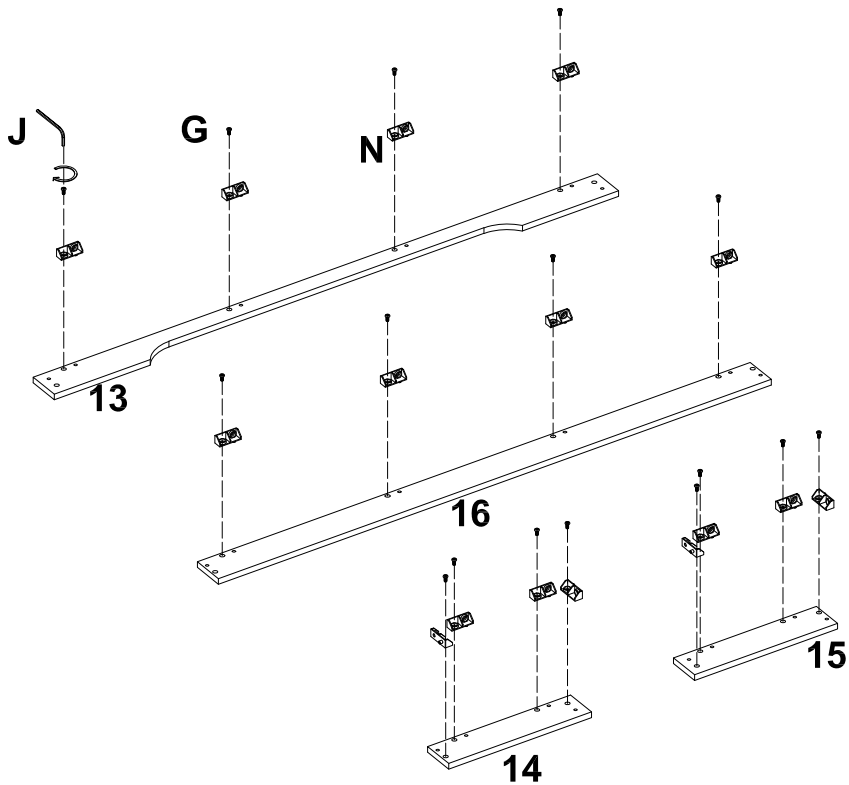

# Step 13

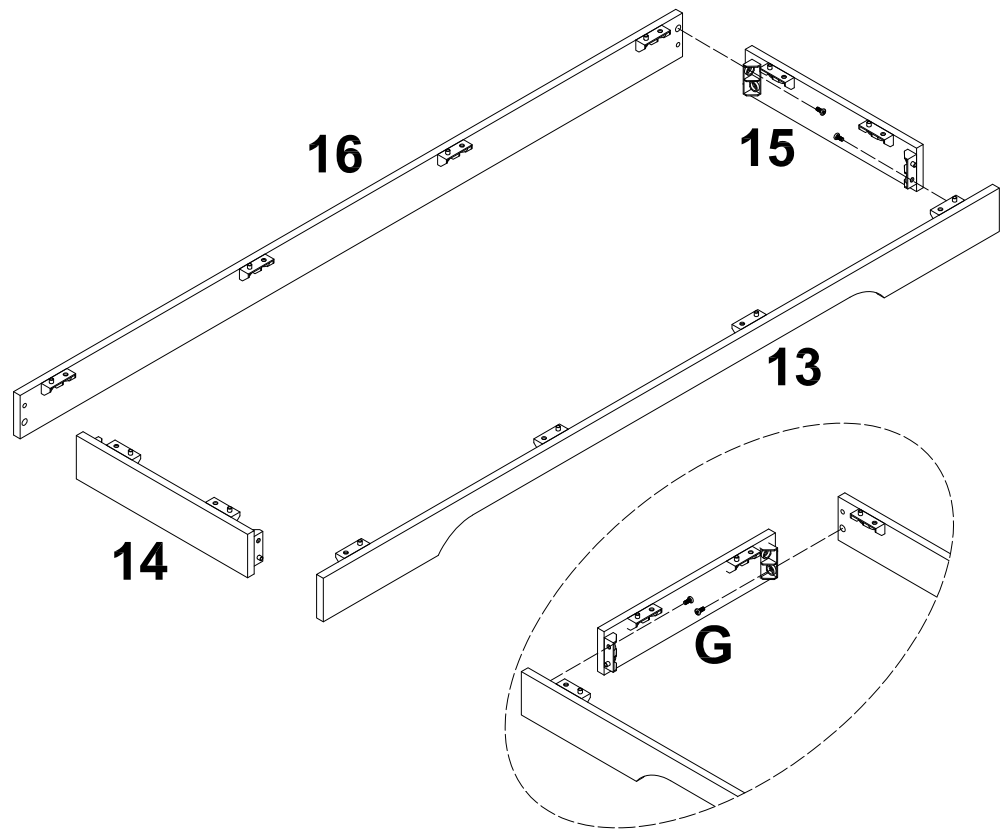

# Step 14

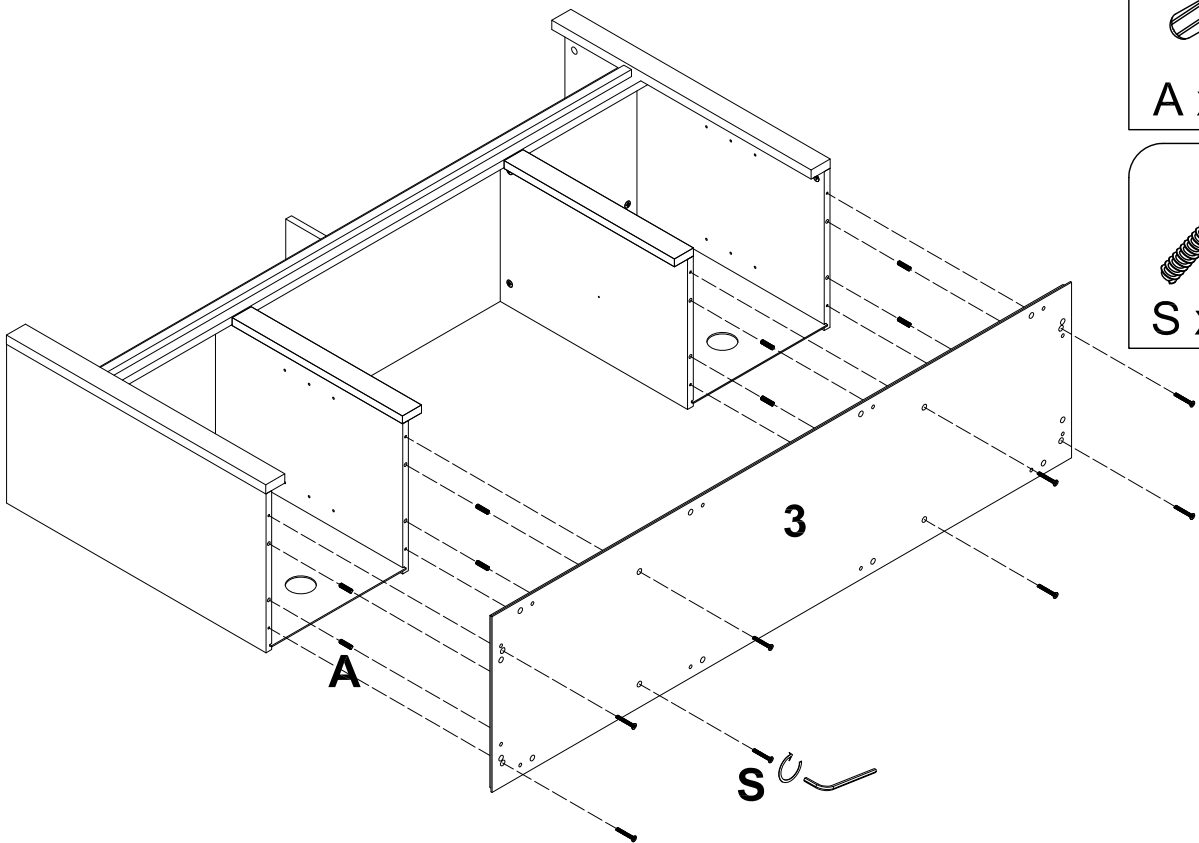
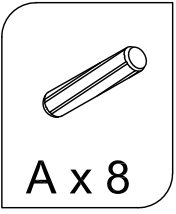

## Step 15



G x12

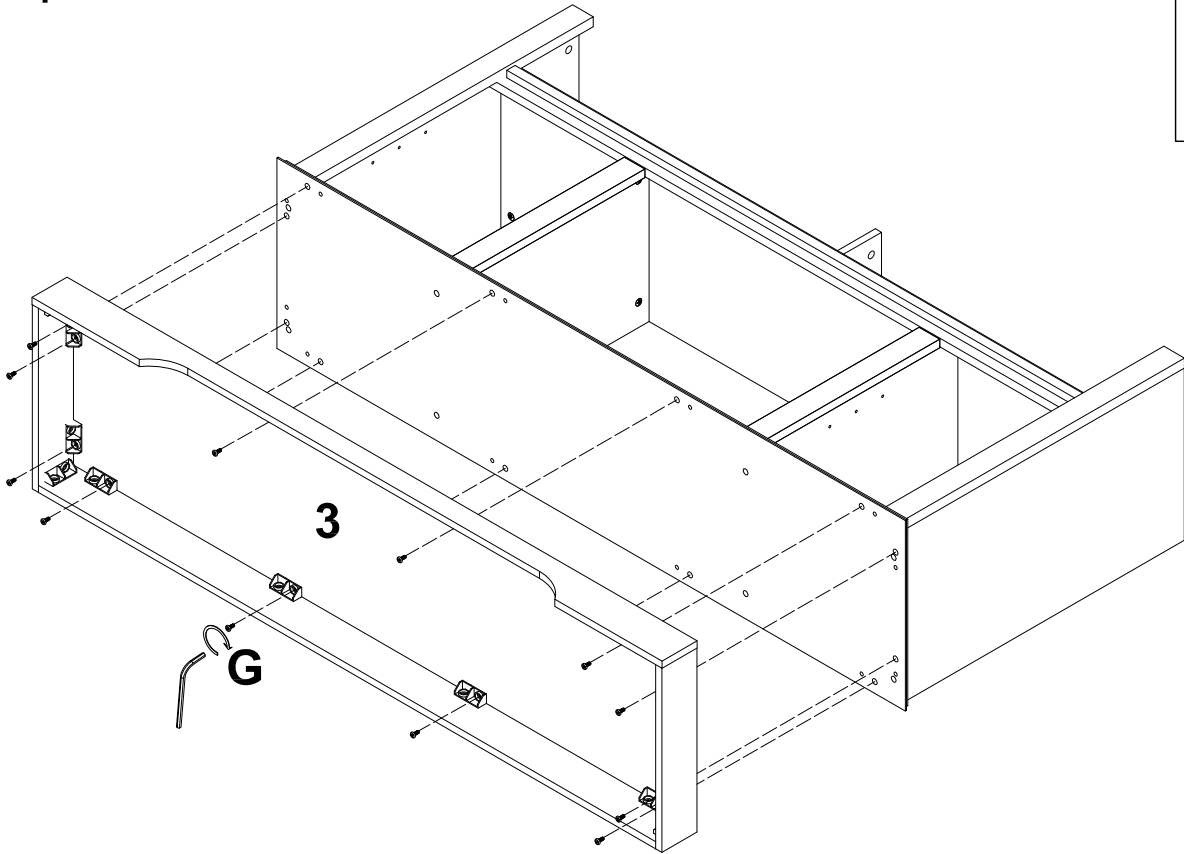

## Step 16

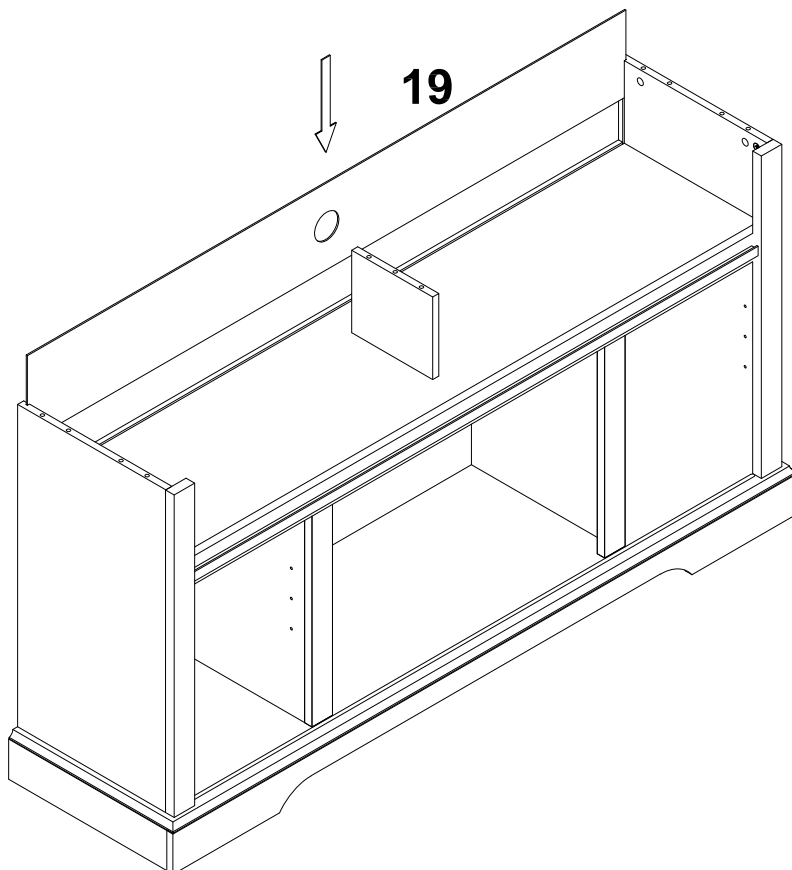

# Step 17

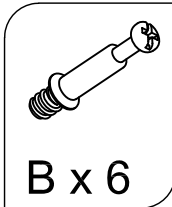
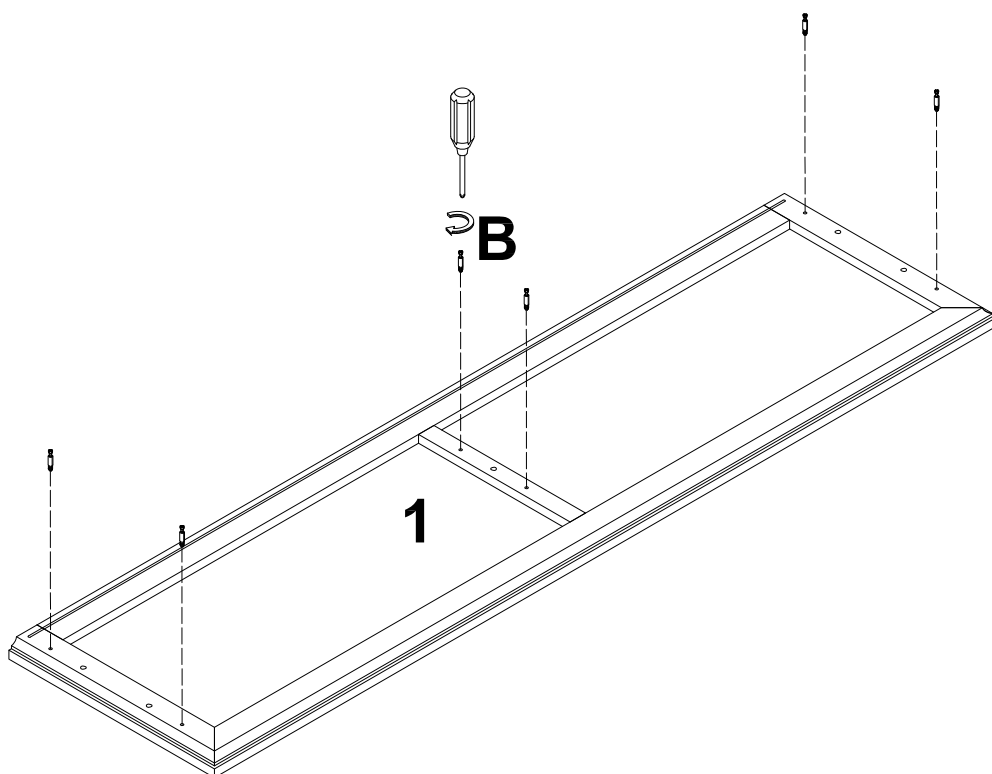

# Step 18

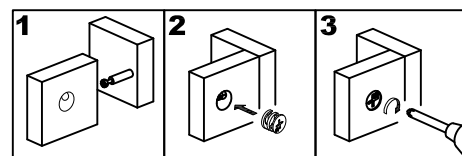
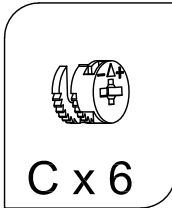
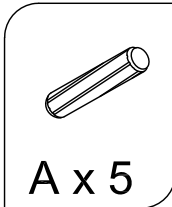
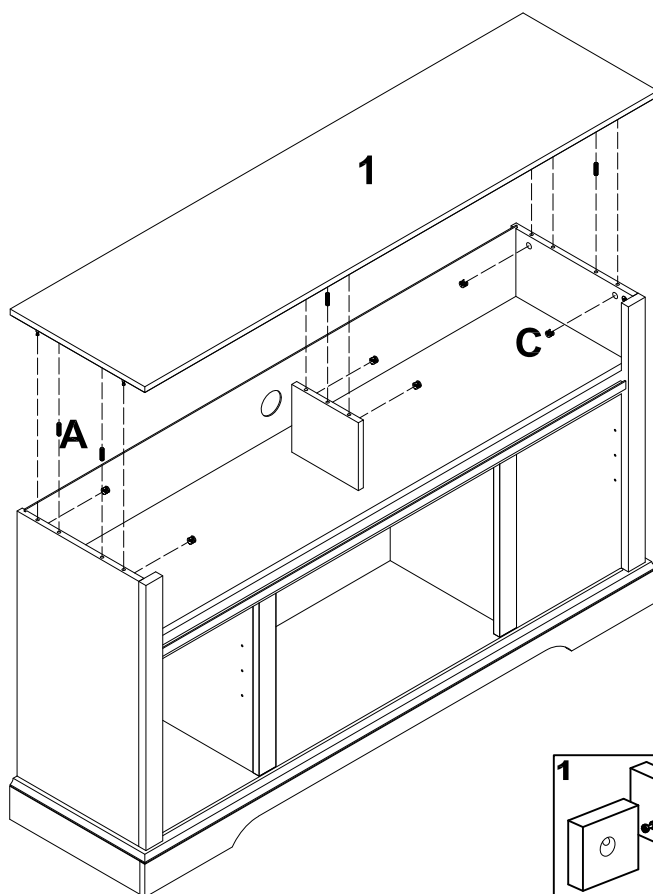

# Step 19

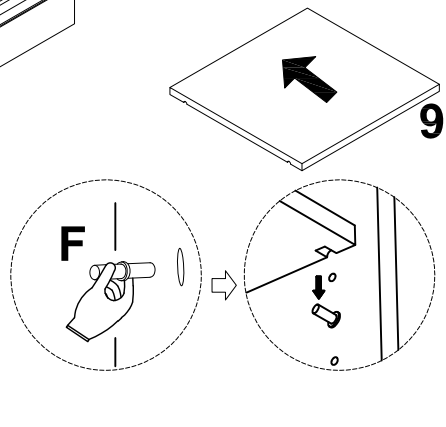
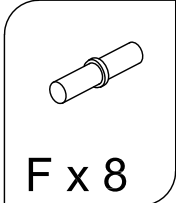
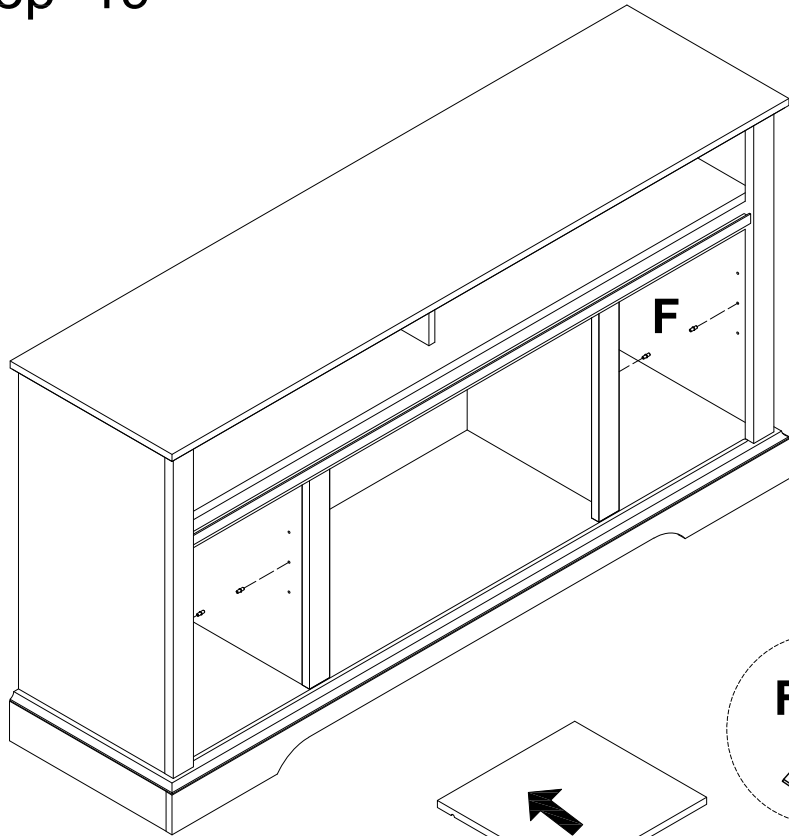

# Step 20

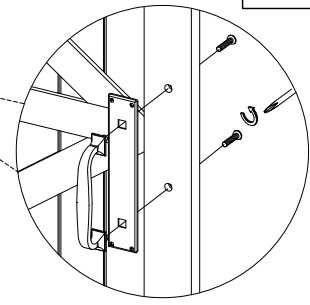
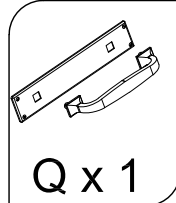
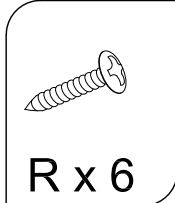
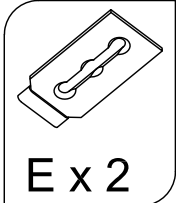
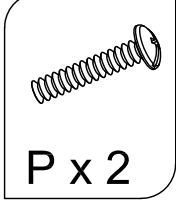
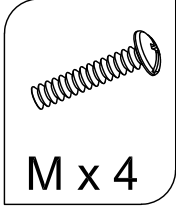
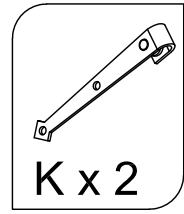
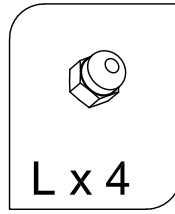
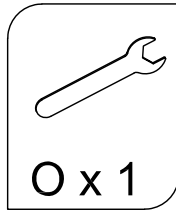
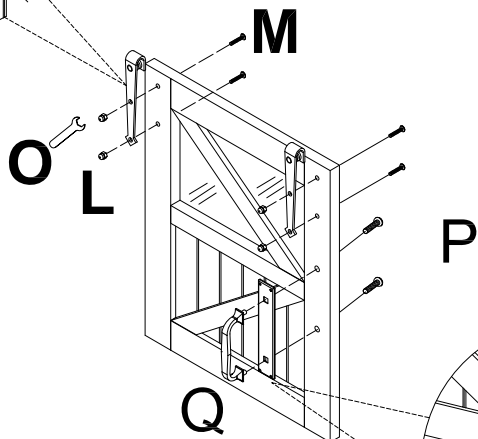
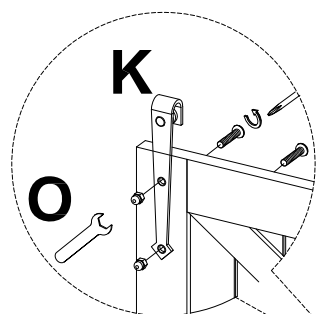
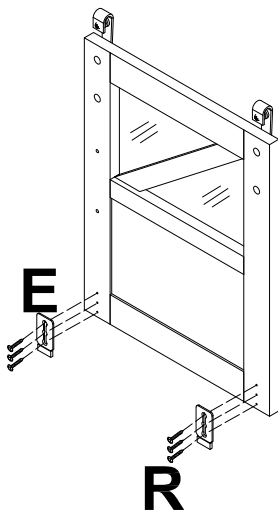

# Step 21

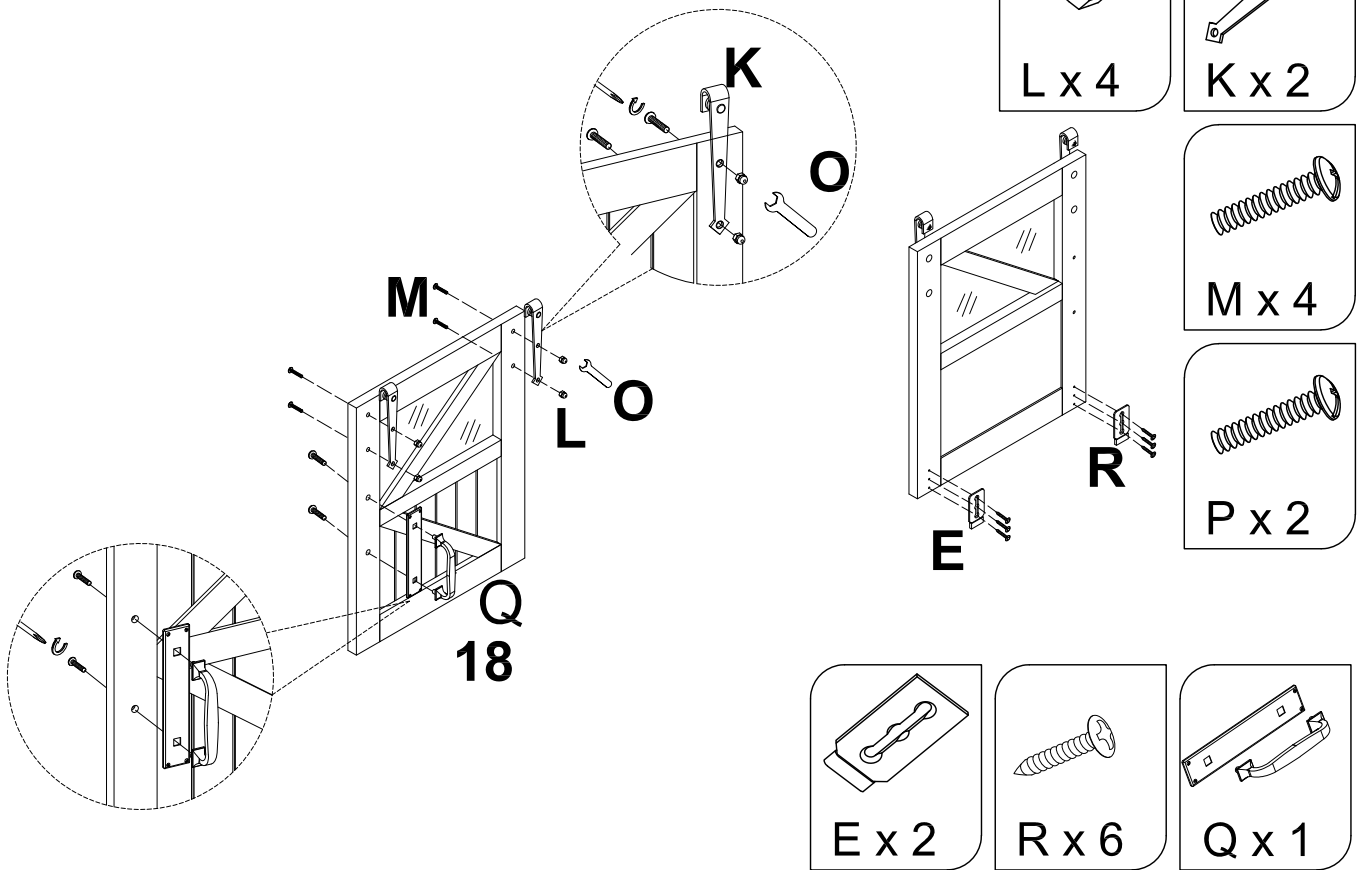

# Step 22

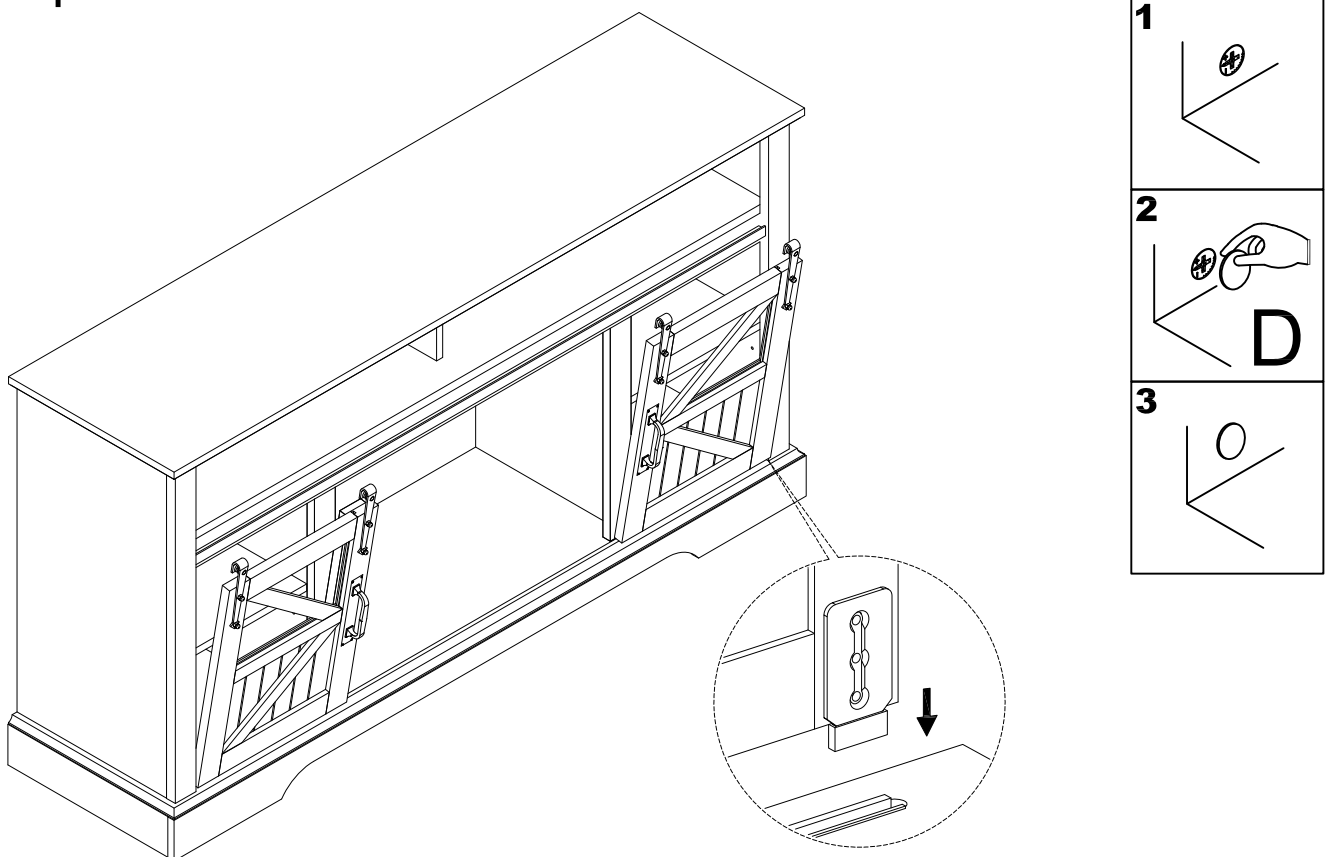

## Step 23

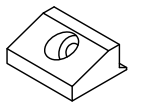
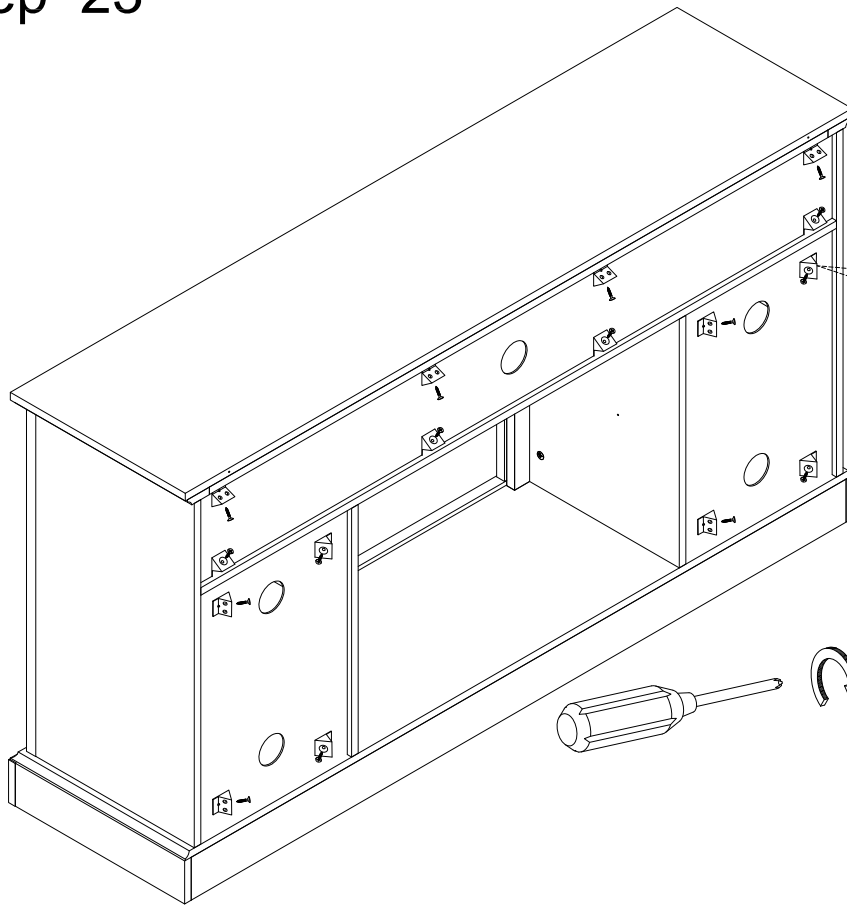

H x16



I x16

## Step 24

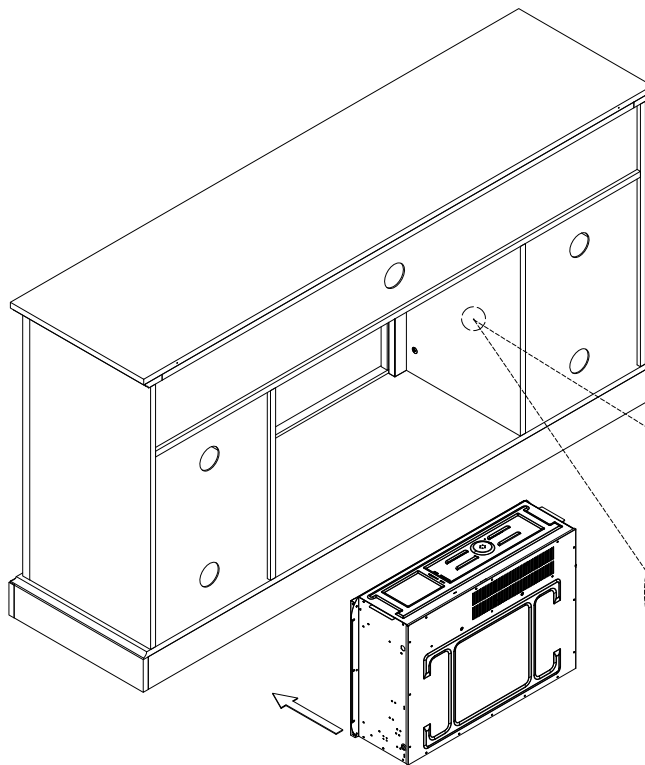

Kindly reminder:  
The installation of insert,  
please refer to the instruction  
of insert, thanks!



# Step 25

## WARNING

Serious or fatal injuries can occur from furniture tipping over. To prevent the furniture from tipping over we recommend that it is permanently fixed to the wall. Wall anchor and hardware are included with this product. Please make sure hardware is suitable for your walls before installing, as different wall materials may require different types of anchors.

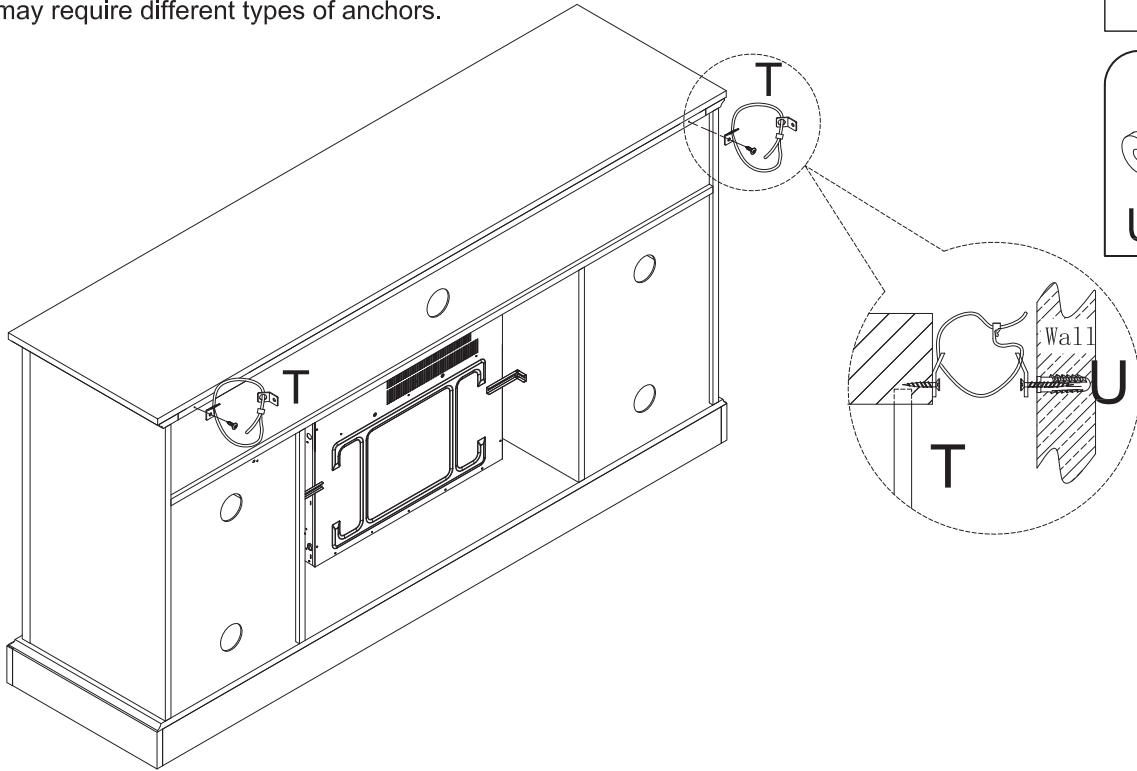

**CAUTION:** This unit is intended for use only with the products and maximum weights indicated. Use with other products or products heavier than the maximum weights indicated may result in instability causing possible injury.

Note: Flat Panel TVs with base support should be placed squarely in the center of the stand with no overhang on any side.

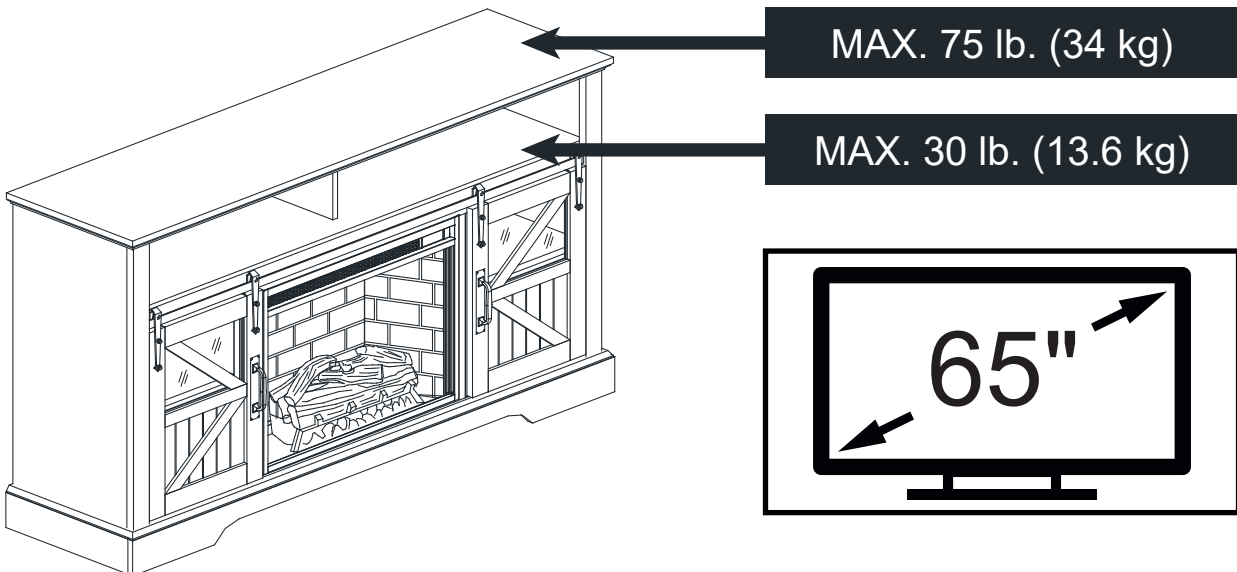

YOU'RE FINISHED!