

# ASSEMBLY INSTRUCTION

WF296629 - WF296630 - WF296631

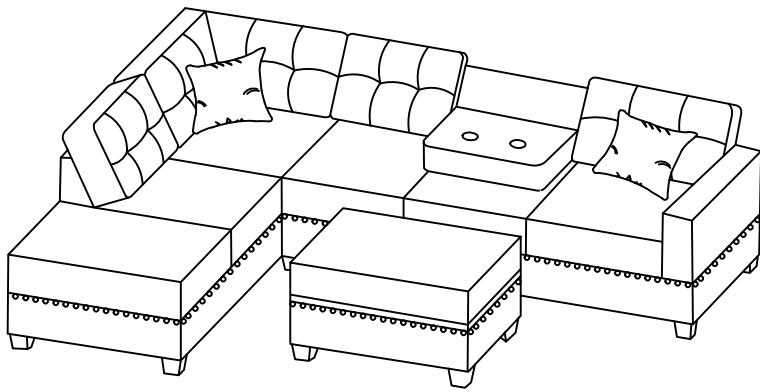

OPTION 1: CHAISE ON LEFT

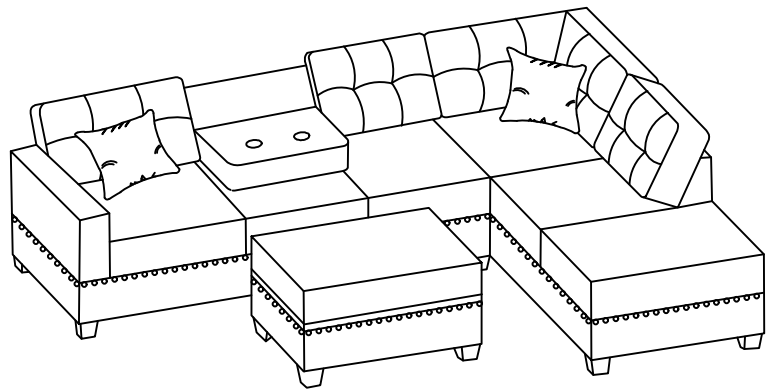

OPTION 2: CHAISE ON RIGHT

## PARTS

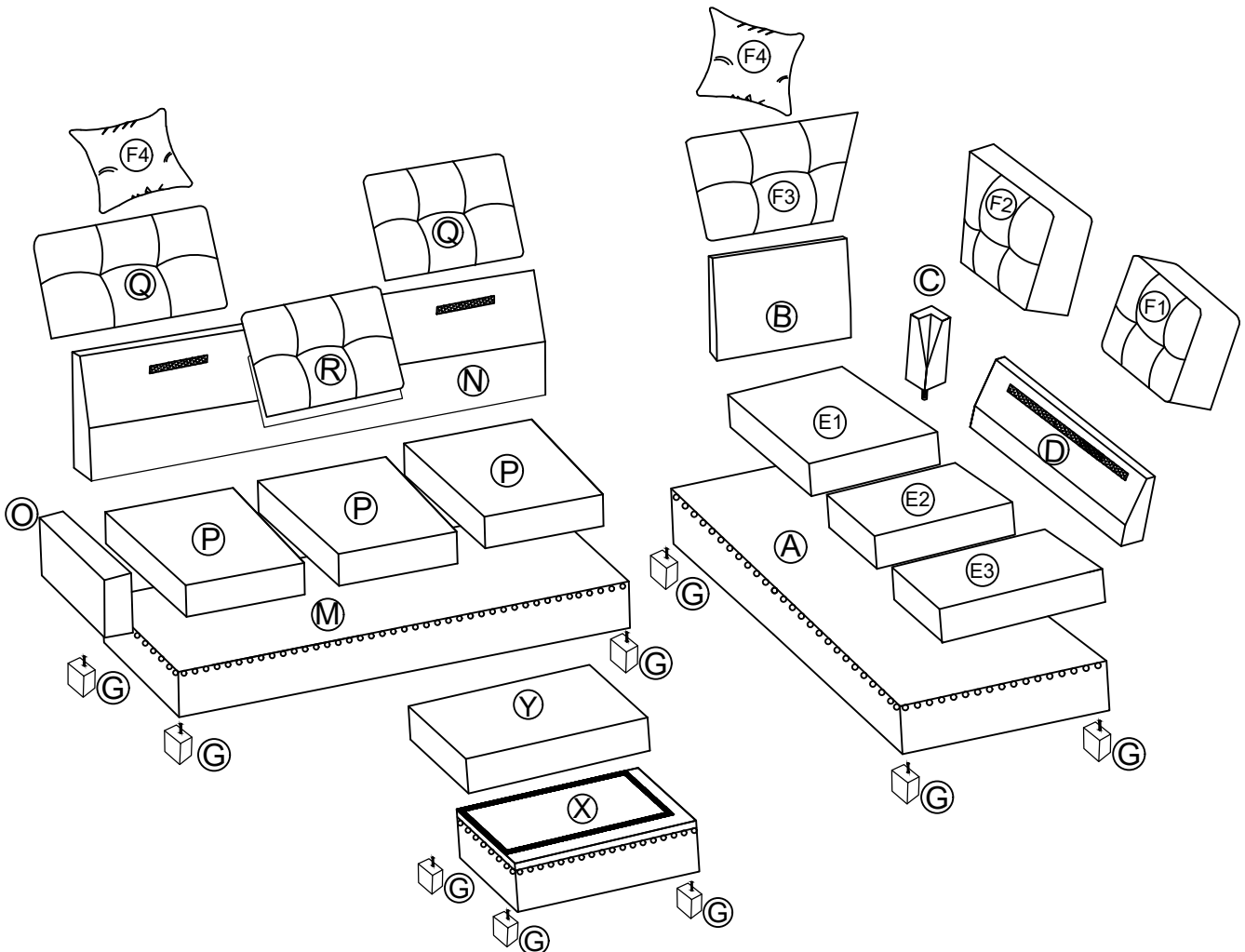

# TIPS

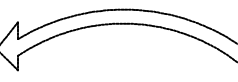
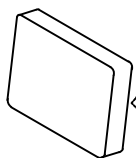
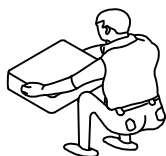
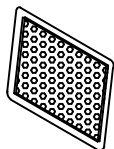

Please allow at least 24 hours for the cushions to recover to its natural state after removing from the package.

## WF296630 - COMPONENT LIST

X

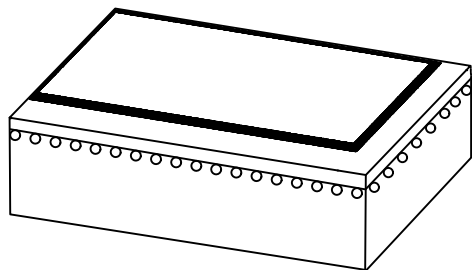

STORAGE OTTOMAN x 1

Y

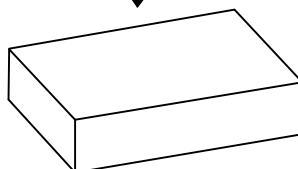
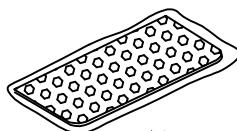

SEAT CUSHION x 1

G

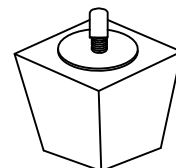

LEG x 4

## WF296631- COMPONENT LIST

M

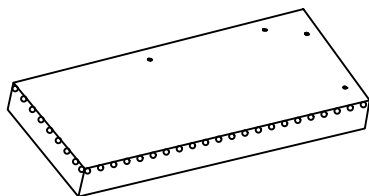

SOFA SEAT x 1

N

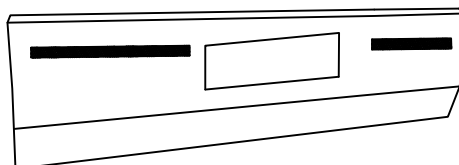

SOFA BACK REST x 1

O

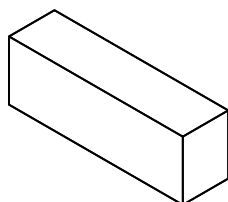

ARM x 1

F4

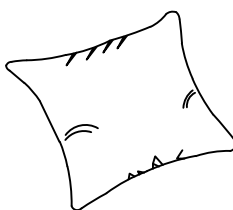

PILLOW x 2

G

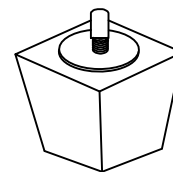

LEG x 4

Q

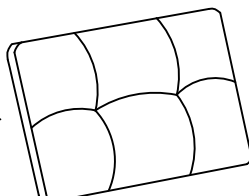
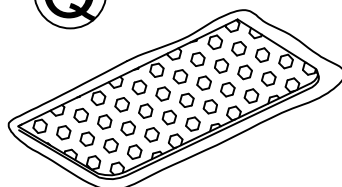

SOFA BACK CUSHION x 2

P

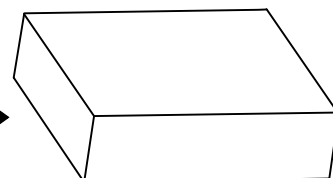
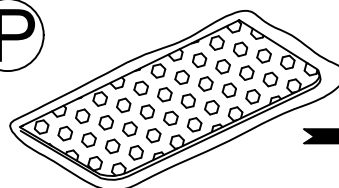

SOFA SEAT CUSHION X 3

# WF296629 - COMPONENT LIST

**A**

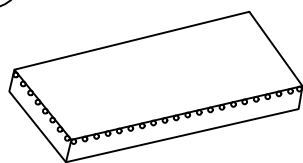

CHAISE SEAT x 1

**B**

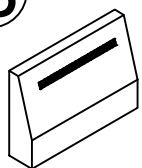

CHAISE BACK REST x 1

**C**



CHAISE BACK CORNER x 1

**R**

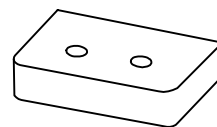

SOFA MIDDLE BACK CUSHION x 1

**D**

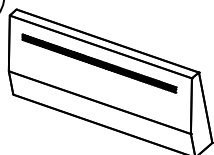

CHAISE BACK REST x 1

**E1**

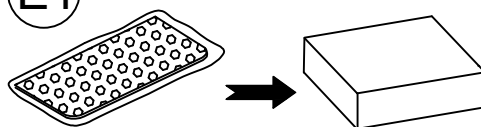

REAR SEAT CUSHION x 1

**E2**

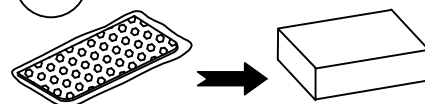

MIDDLE SEAT CUSHION x 1

**E3**

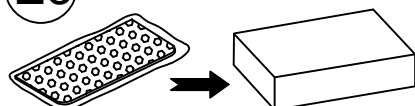

FRONT SEAT CUSHION x 1

**F1**

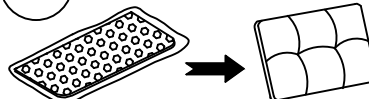

FRONT BACK CUSHION x 1

**F2**

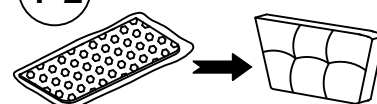

MIDDLE BACK CUSHION x 1

**F3**

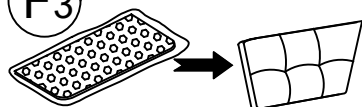

REAR BACK CUSHION x 1

**G**

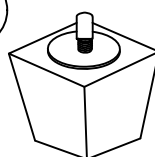

LEG x 4

## HARDWARE (in box WF296631)

**H**

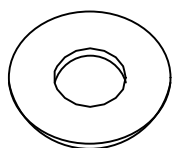

FLAT WASHER  
Ø5/16" x 22MM  
11PCS

**I**



HEX NUT  
Ø5/16" x 12MM  
11PCS

**J**



BOLT Ø5/16" x 90MM  
11PCS

**S**

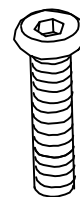

BOLT Ø1/4" x 20MM  
4PCS

**L**

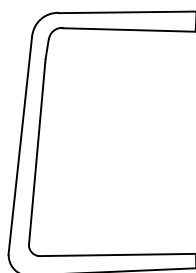

METAL CONNECTOR  
2PCS

**T**

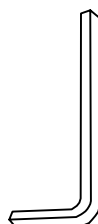

ALLEN KEY  
1PC

**K**

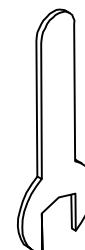

OPEN WRENCH  
1PC

### Step 1:

Remove the hardware and the leg box from packet.

Place all parts on a clean, smooth surface

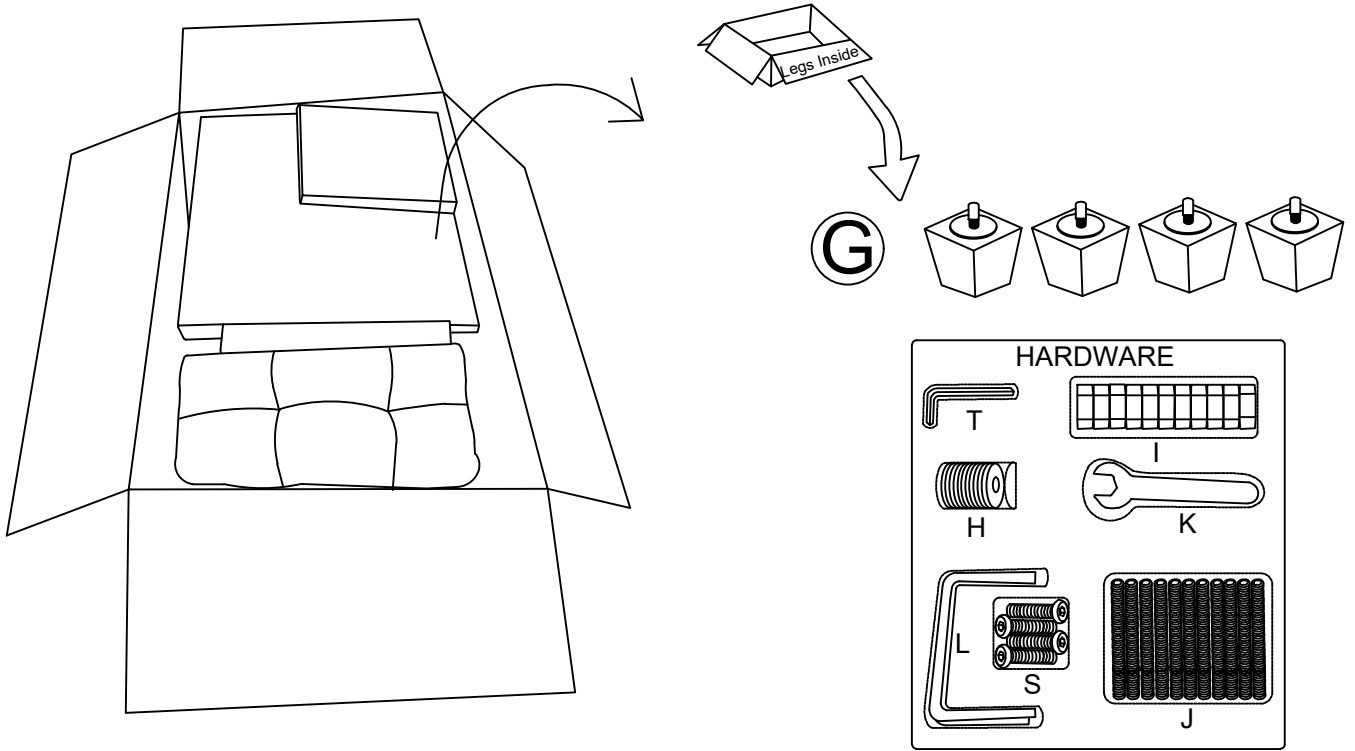

### Step 2:

Manually screw J to C, B and D as shown.

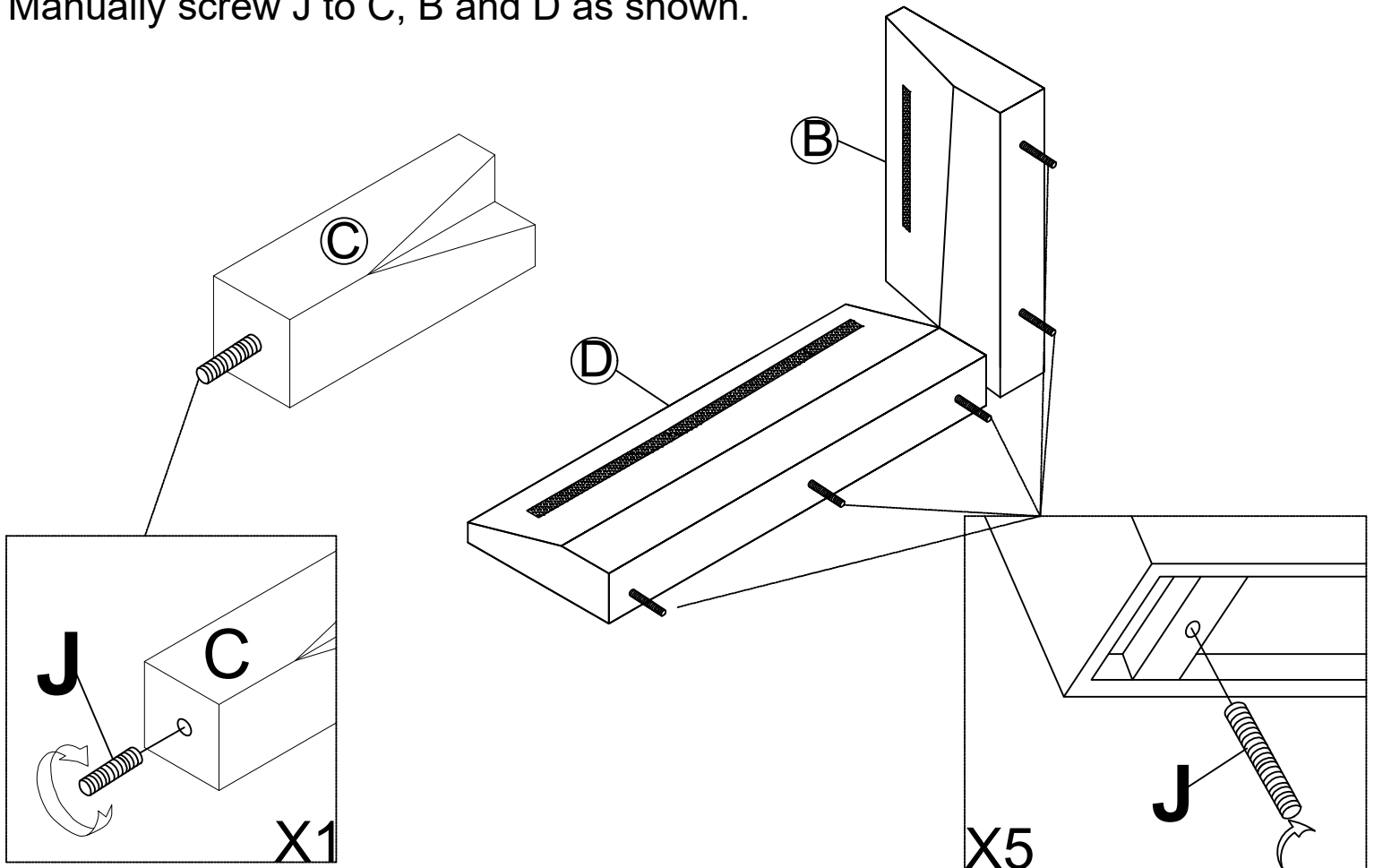

### Step 3:

Align the backrest D, C and B with the hole in A. Fix it by using H&I

#### Option 1

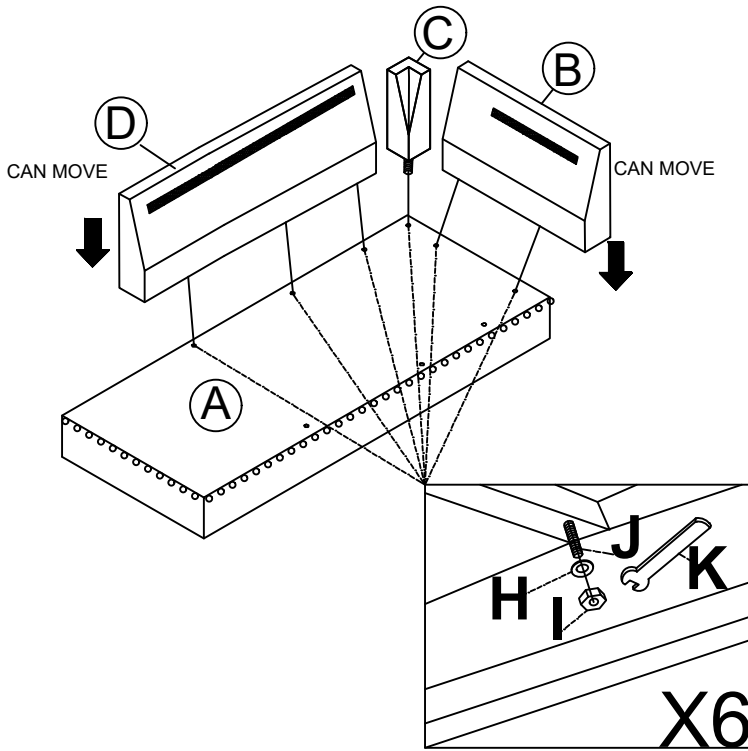

#### Option 2

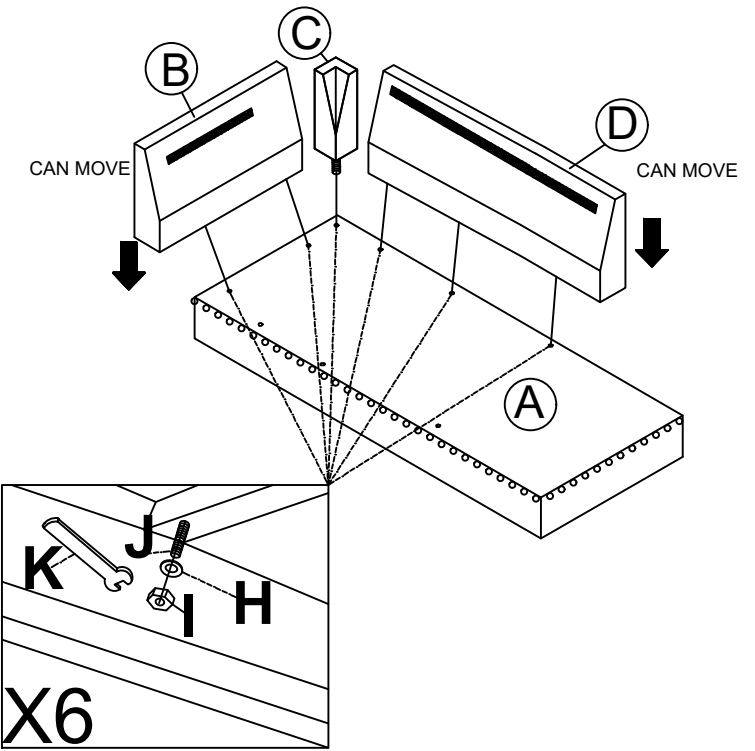

### Step 4:

Manually legs G x 4 to A , as shown

▲ Please remove the protective cap on the tip of thread before assembling.

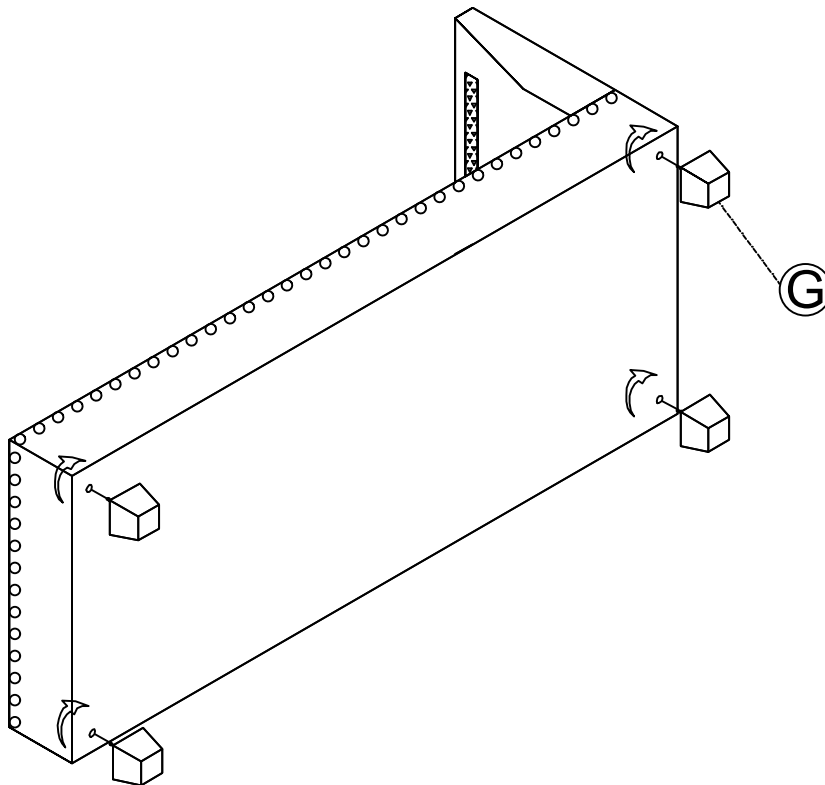
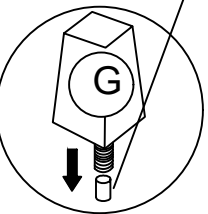

# BOTTOM VIEW

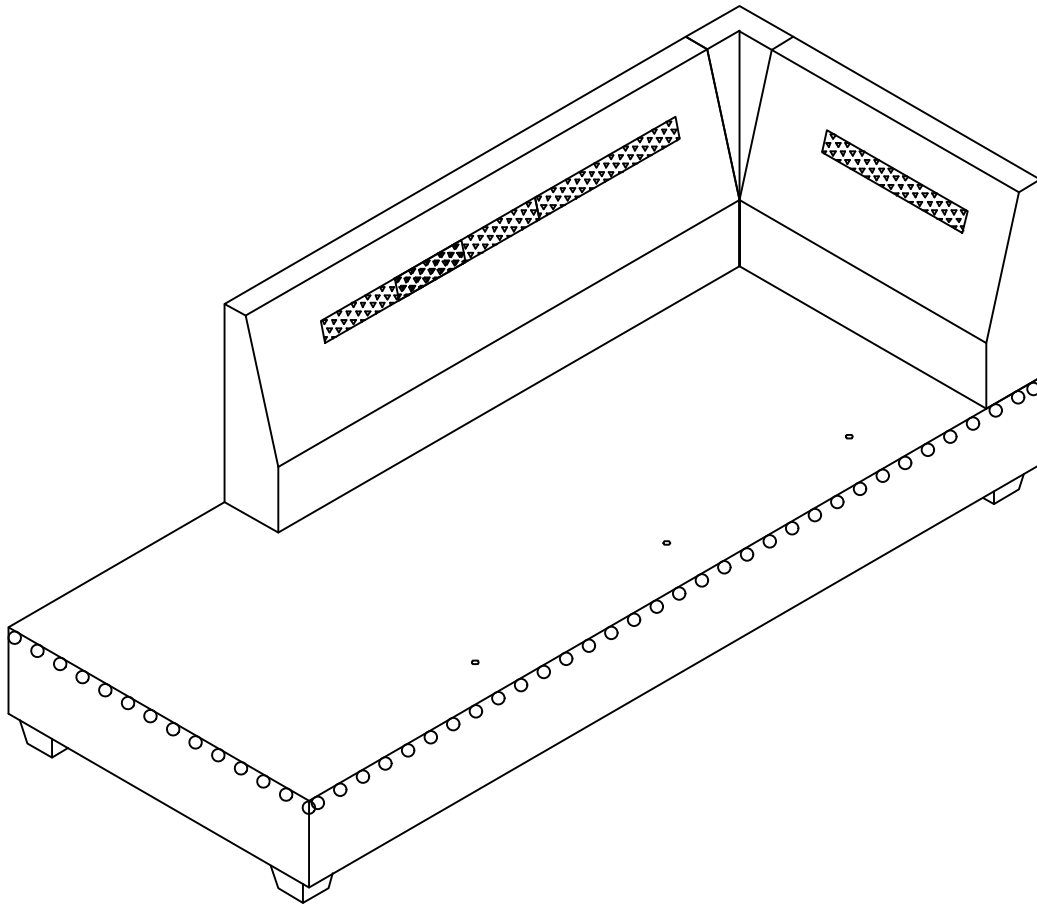

**Step 5:**  
Manually screw J to N,O as shown.

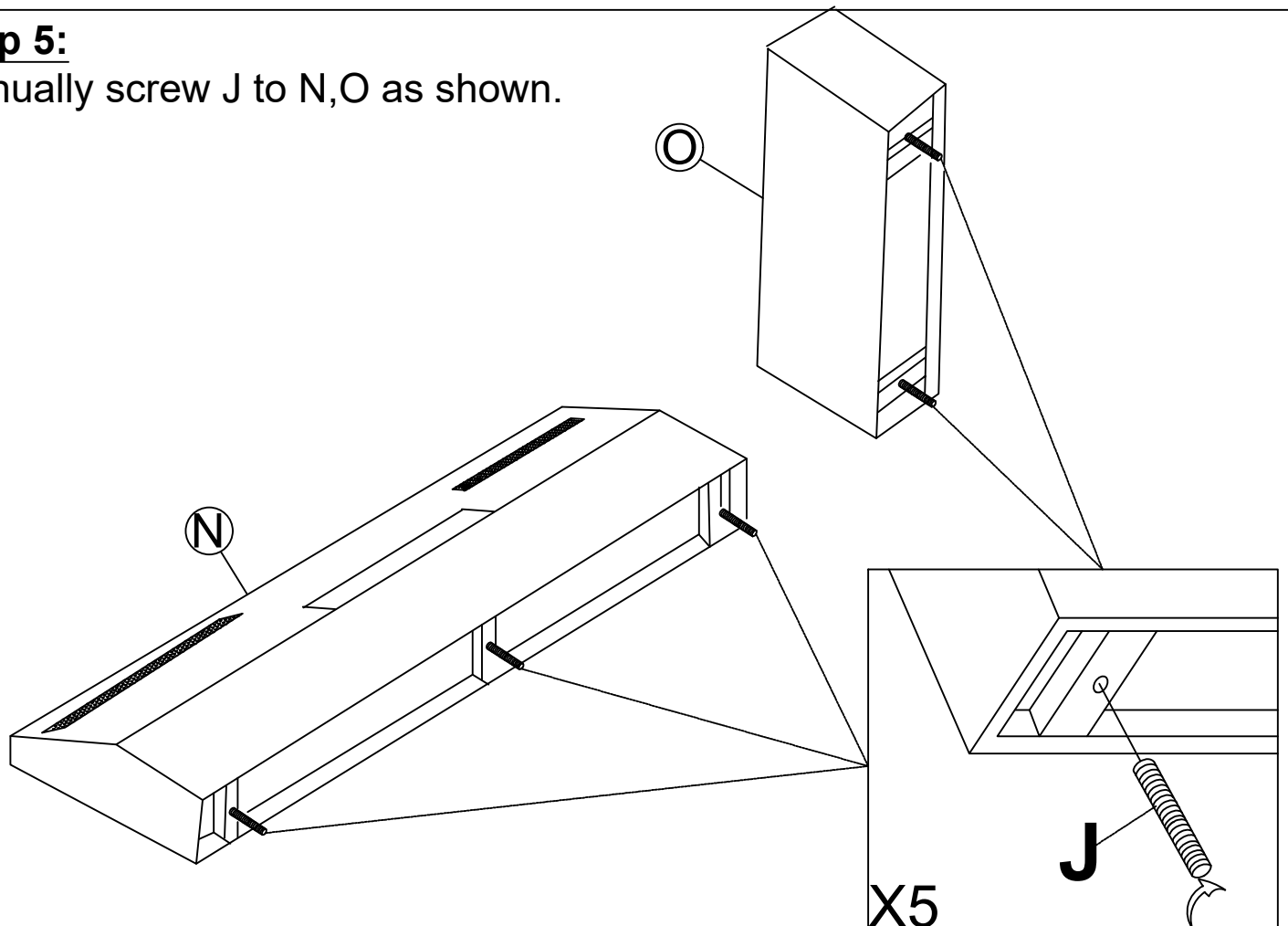

**Step 6:**

Align the backrest O&N with the hole in M. Fix it by using H & I.

Option 1

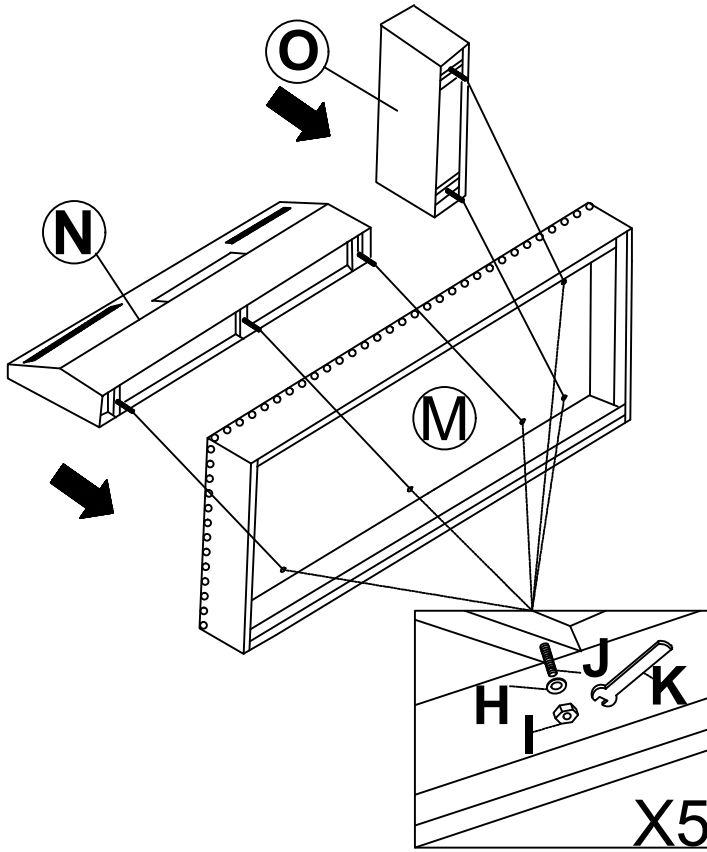

Option 2

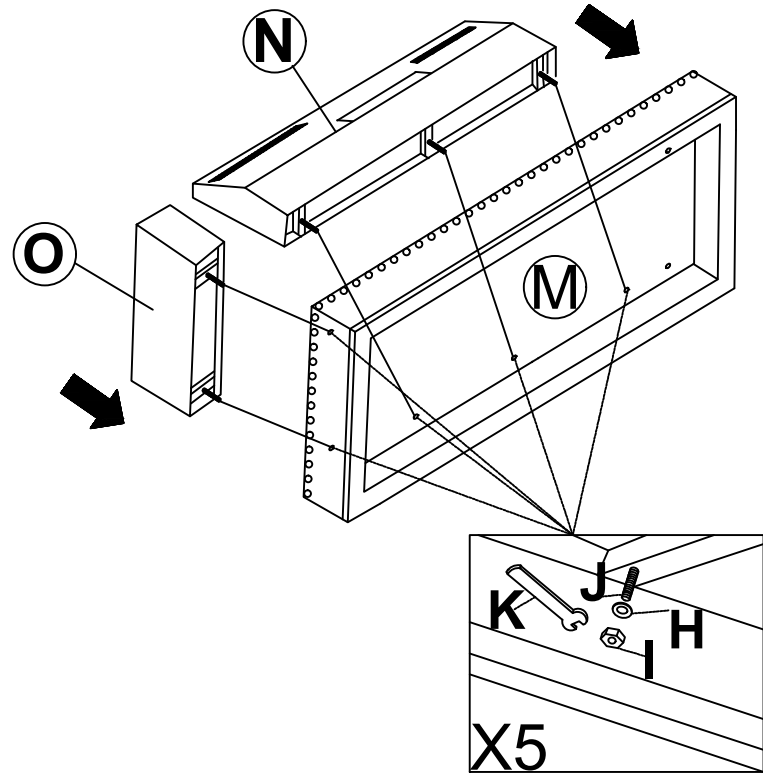

**Step 7:**

Manually legs G x 4 to M , as shown

▲ Please remove the protective cap on the tip of thread before assembling.

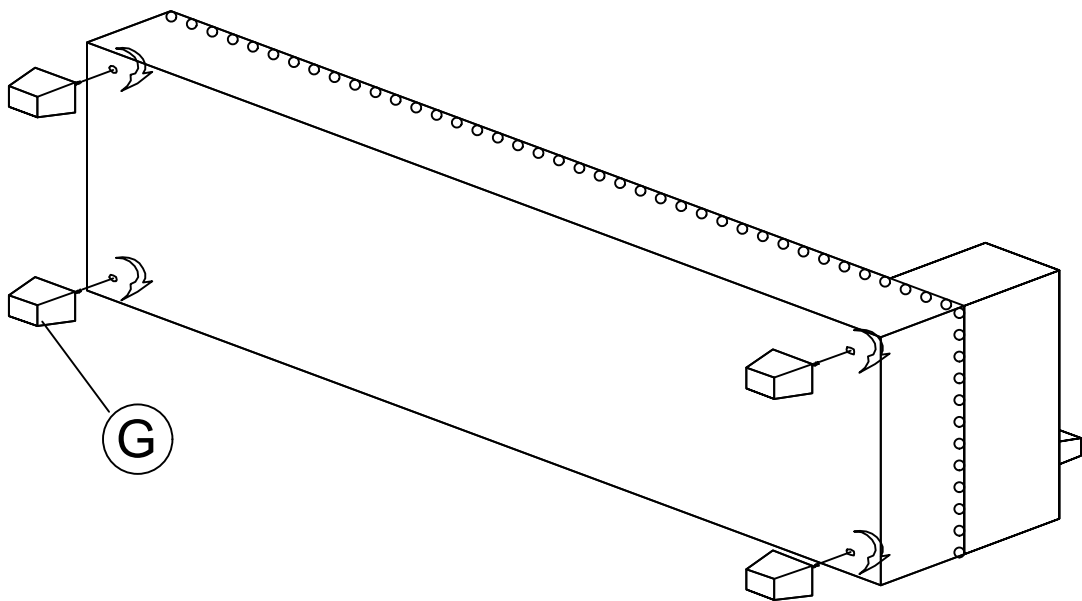
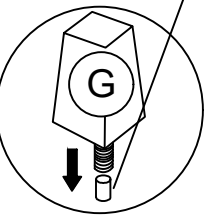

# BOTTOM VIEW

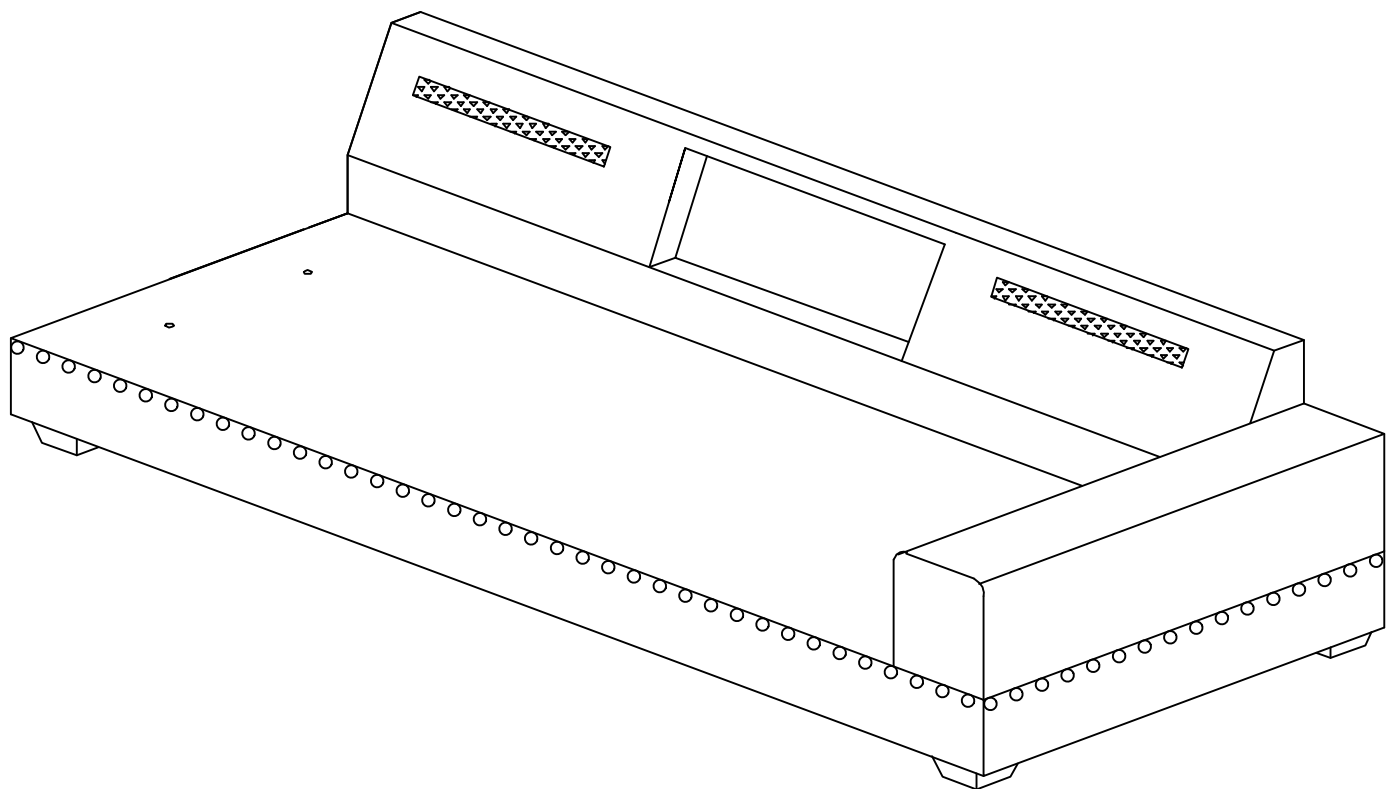

## **Step 8:**

Insert the U-shaped part L into the hole to fix base.

Option 1

Option 2

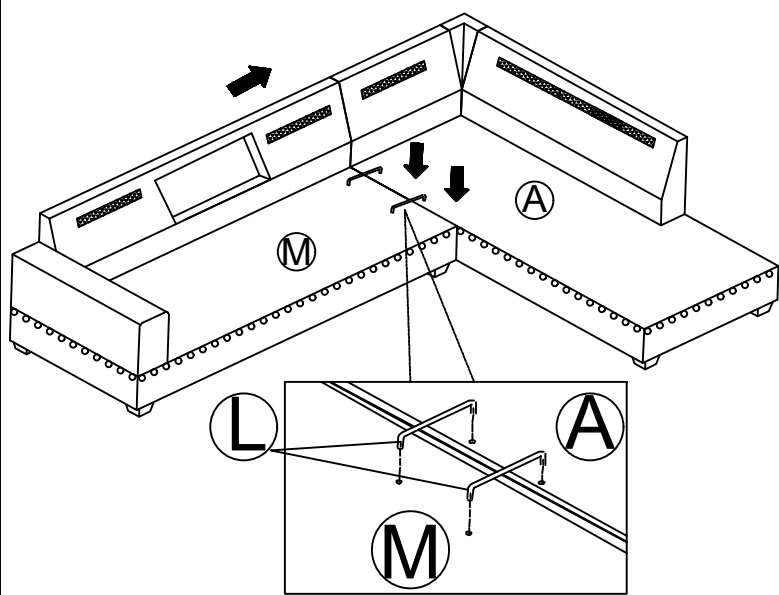
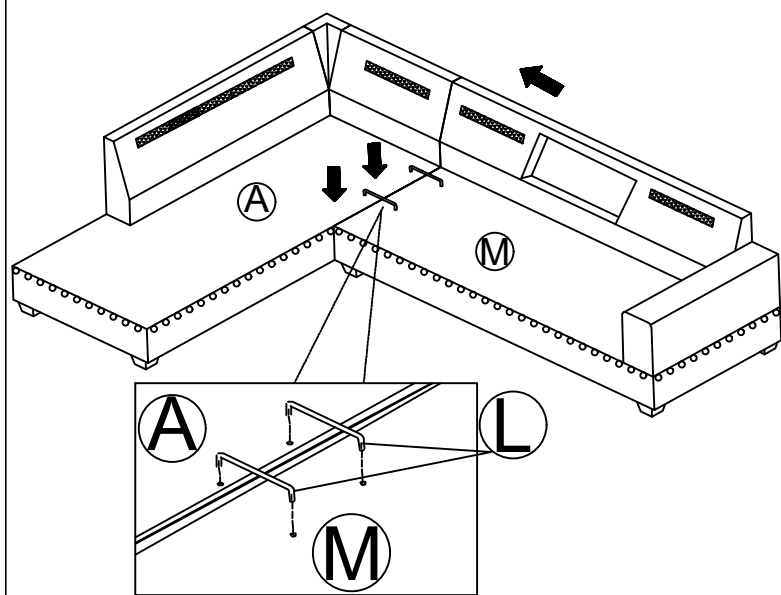



**Step 9:**

Attach R to the back rest N by using S x 4.

Option 1

Option 2

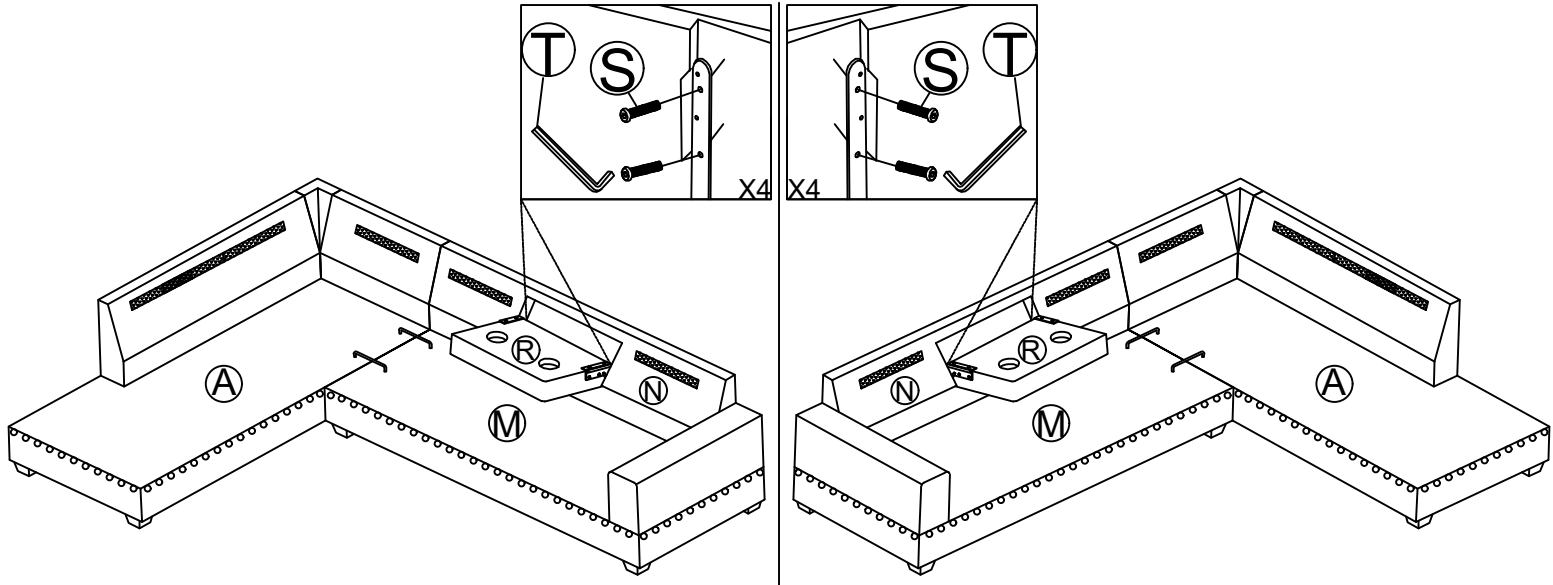

**Step 10:**

Remove seat cushion from their package

Place E3x1, E2x1, E1x1 and Px3 onto the sofa.

Option 1

Option 2

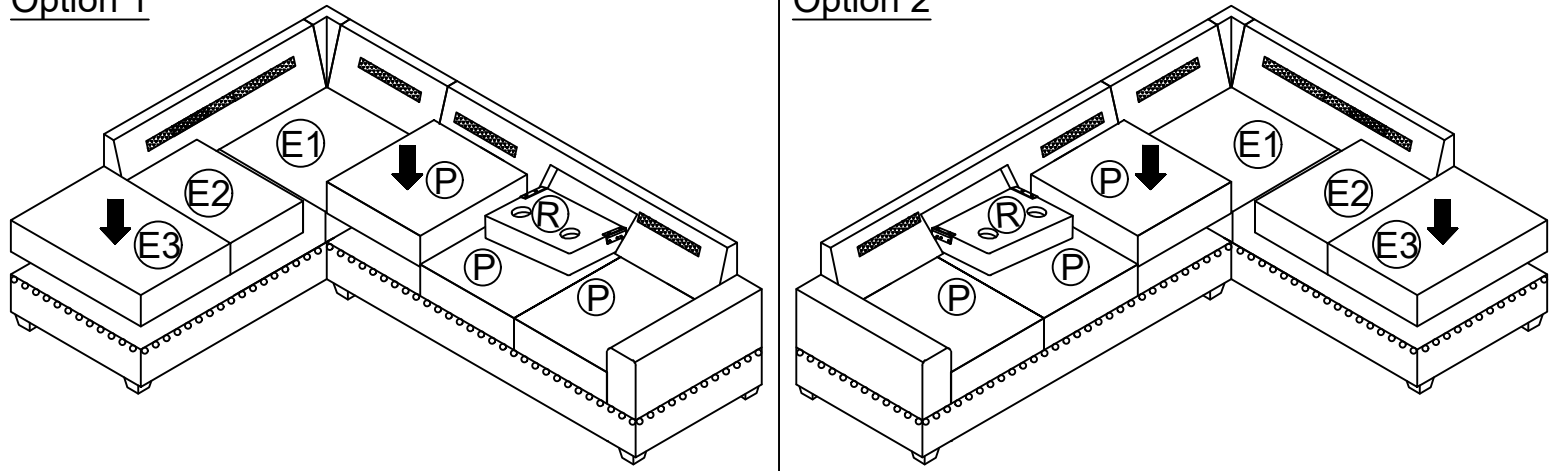

**Tips:** Stretch, pull down and pat seat cushions and back cushions to return nature shape and state.

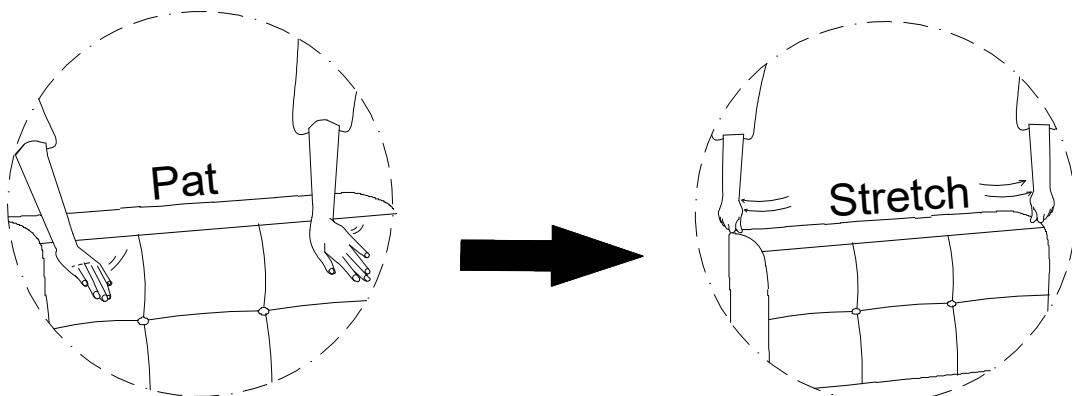

**Step 11:**

Remove back cushion from their package

Place F1x1, F2x1, F3x1, F4x1 and Qx2 onto the sofa.

Option 1

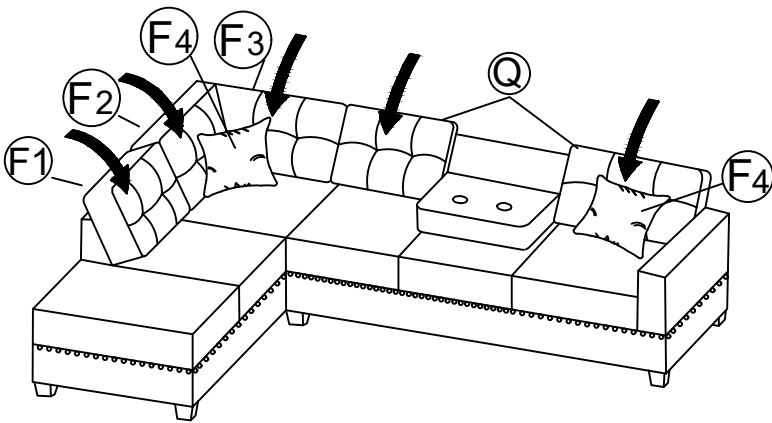

Option 2

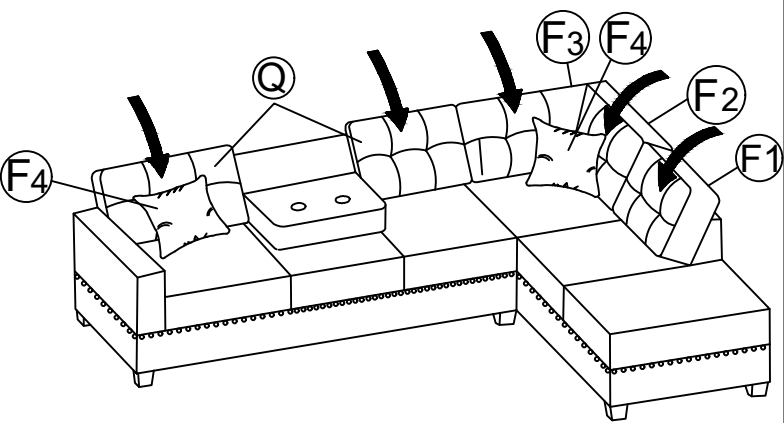

**Step 12:**

Manually legs G x 4 to X, as shown.

Attach seat cushion Y x 1 to X.

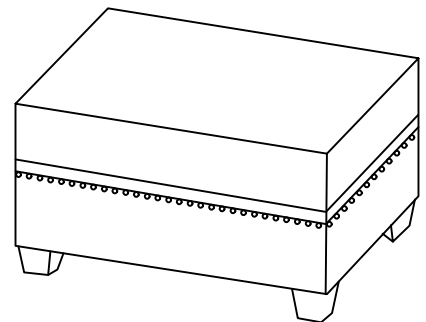
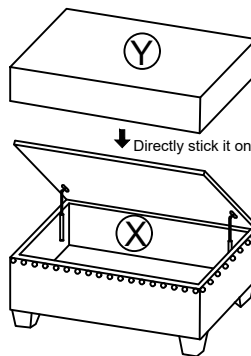
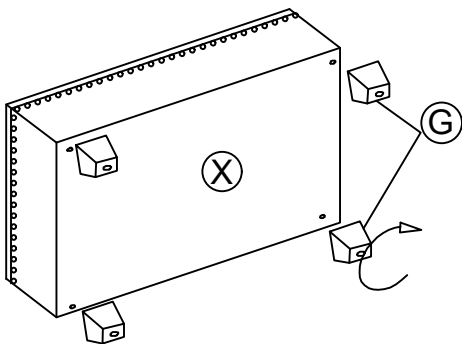

**Assembly Completed !**

THE CONSOLE PIECE CAN BE DROPPED DOWN AND TURN INTO AN ARMREST PANEL WITH CUP HOLDERS

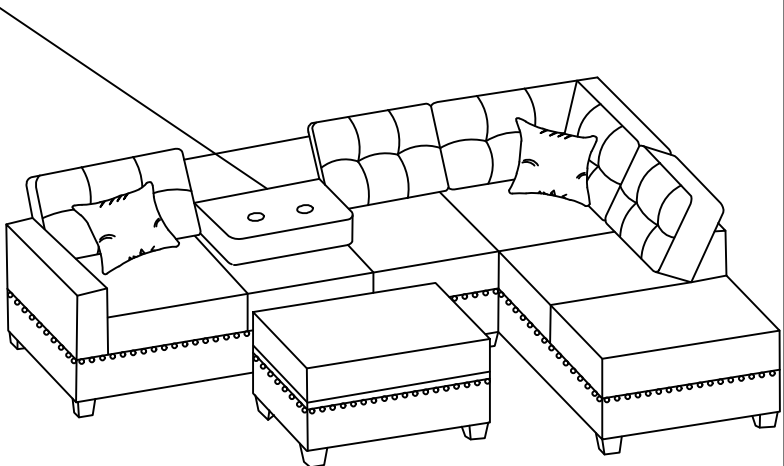
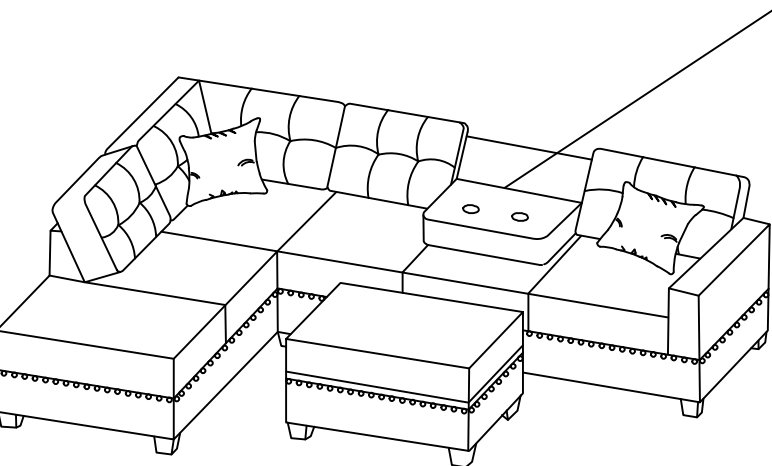

**OPTION 1: CHAISE ON LEFT**

**OPTION 2: CHAISE ON RIGHT**