

Assembly Instruction

SKU:WF310329AAD/WF310331AAD/WF310330AAD

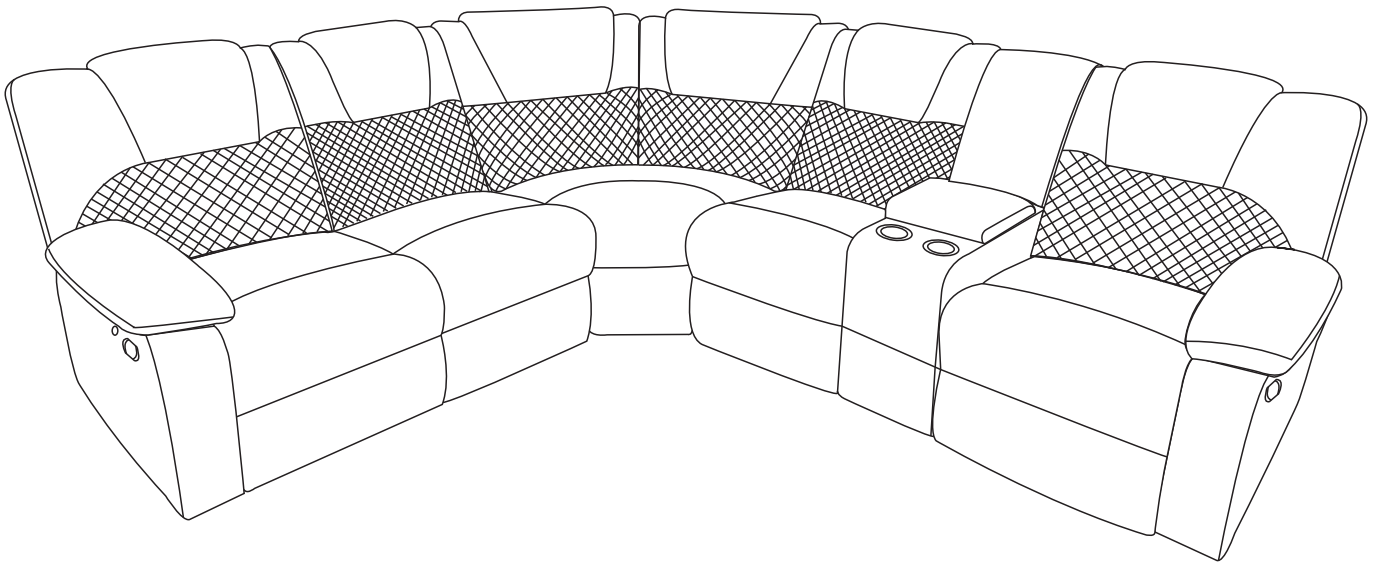

PARTS

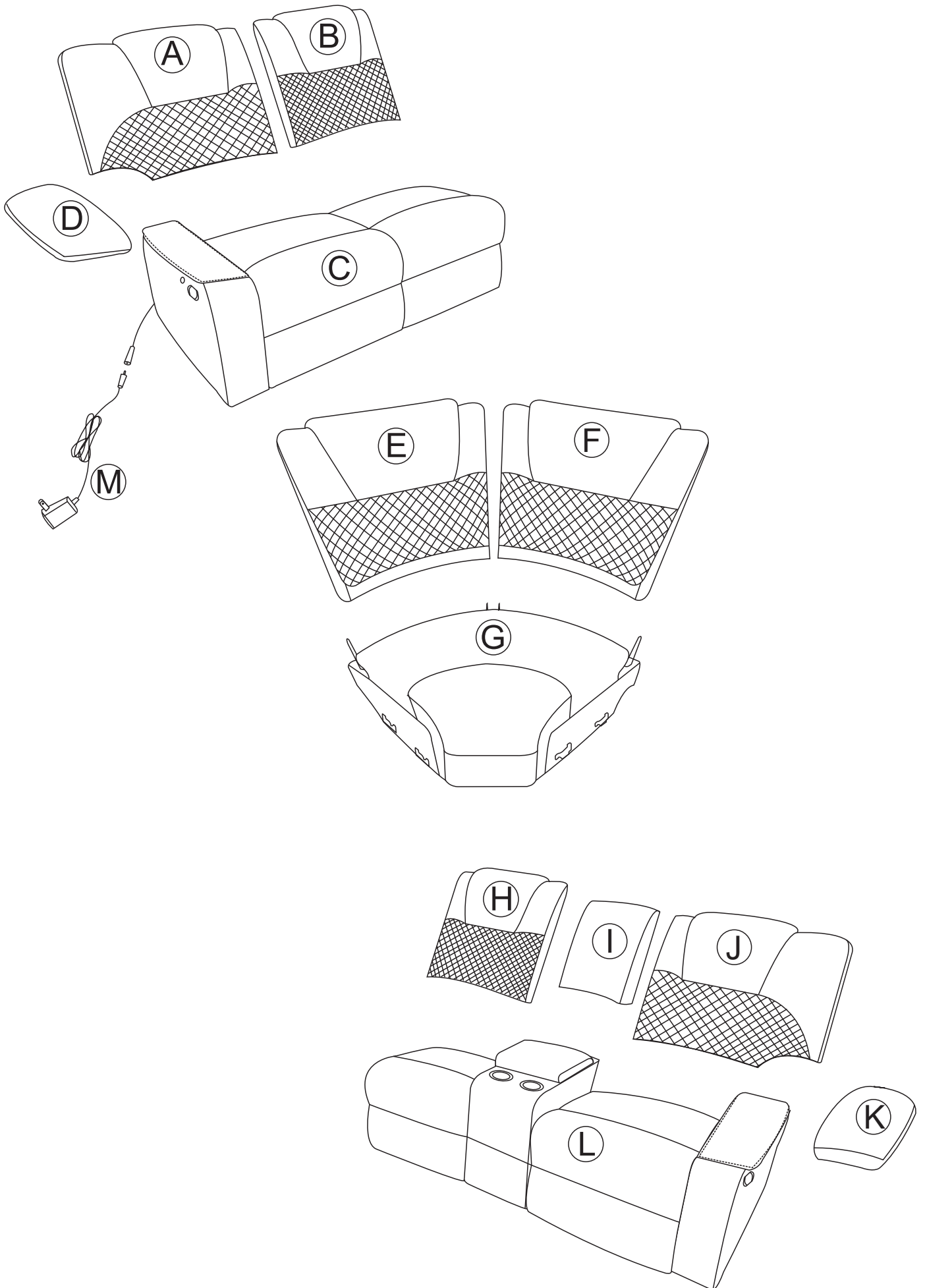

PARTS LIST - BOX 1

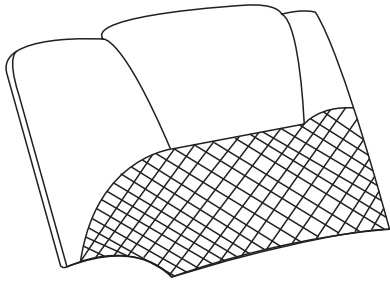

A

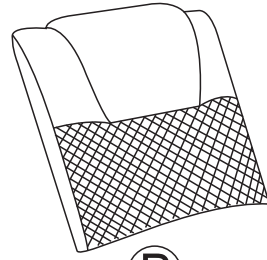

B

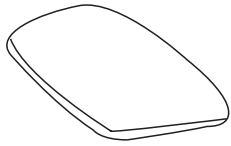

D

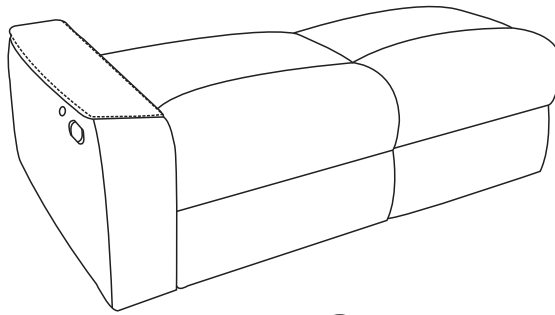

C

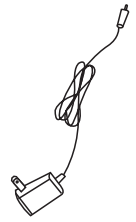

M

PARTS LIST - BOX 2

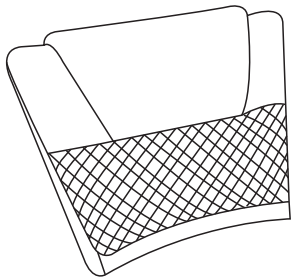

E

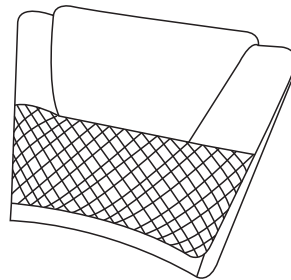

F

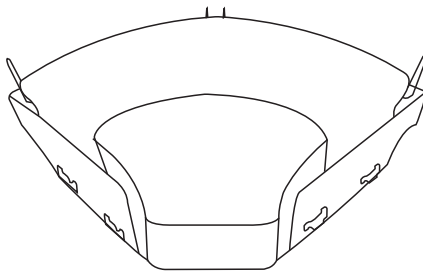

G

PARTS LIST - BOX 3

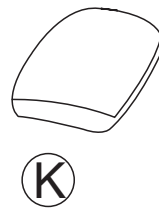
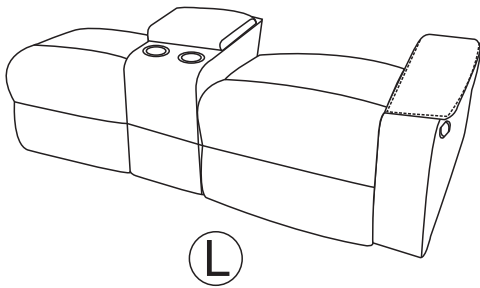
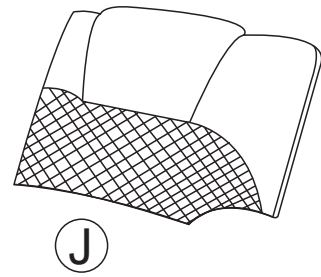
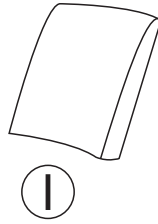
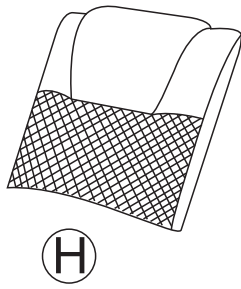

STEP 1:

Attach backrest (A/B/D) to seat (C) by aligning and inserting metal brackets. Connect power cable (M) to seat (C) port. Ensure brackets are fully inserted and secured.

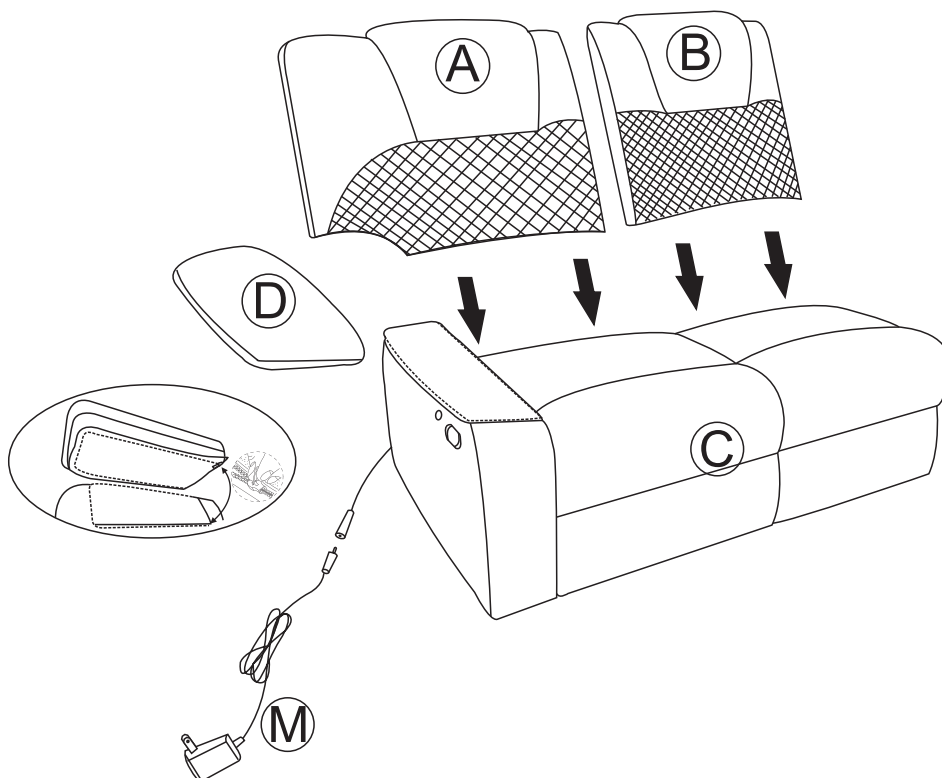

STEP 2:

Attach backrest (E/F) to seat (G) by aligning and inserting metal brackets. Ensure brackets are fully inserted and secured.

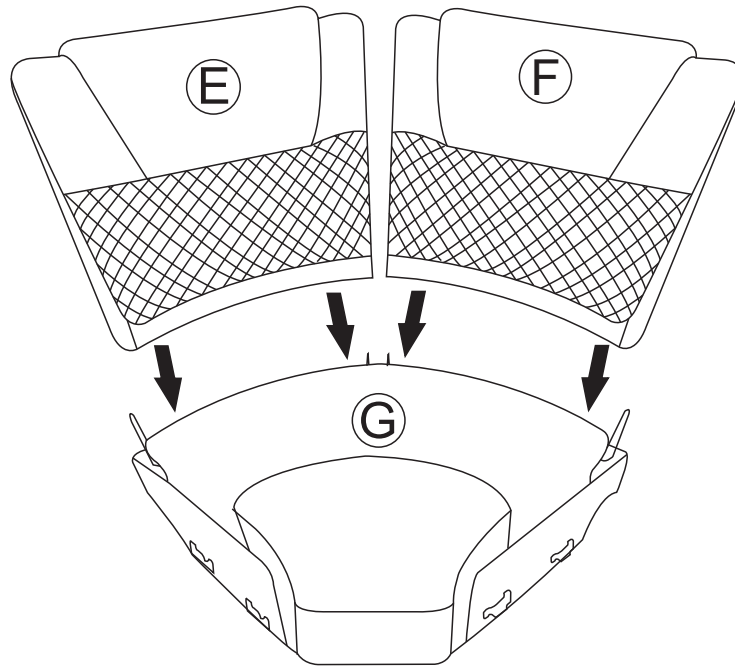

STEP 3:

Take out I/K and L from BOX3. Position them as shown:

TOP VIEW

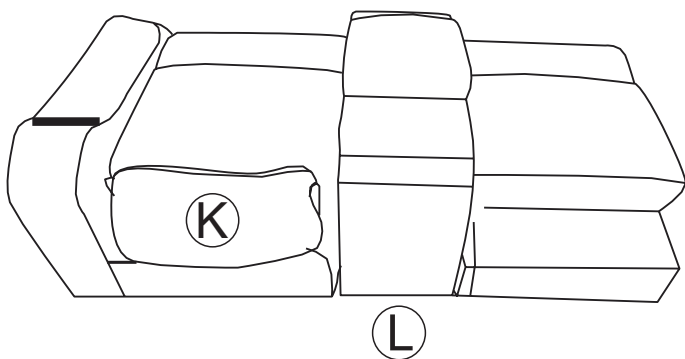

BOTTOM VIEW

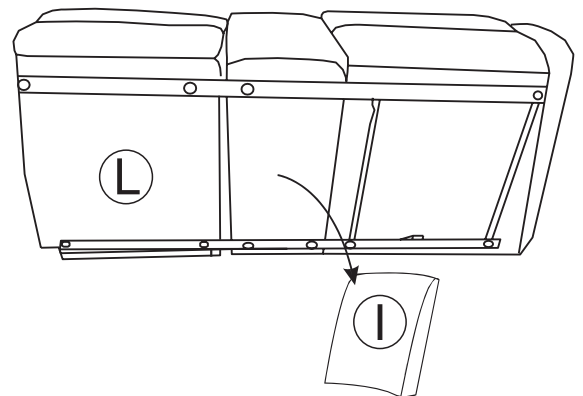

STEP 4:

Attach backrest (H/I/J/K) to seat (L) by aligning and inserting metal brackets. Ensure brackets are fully inserted and secured.

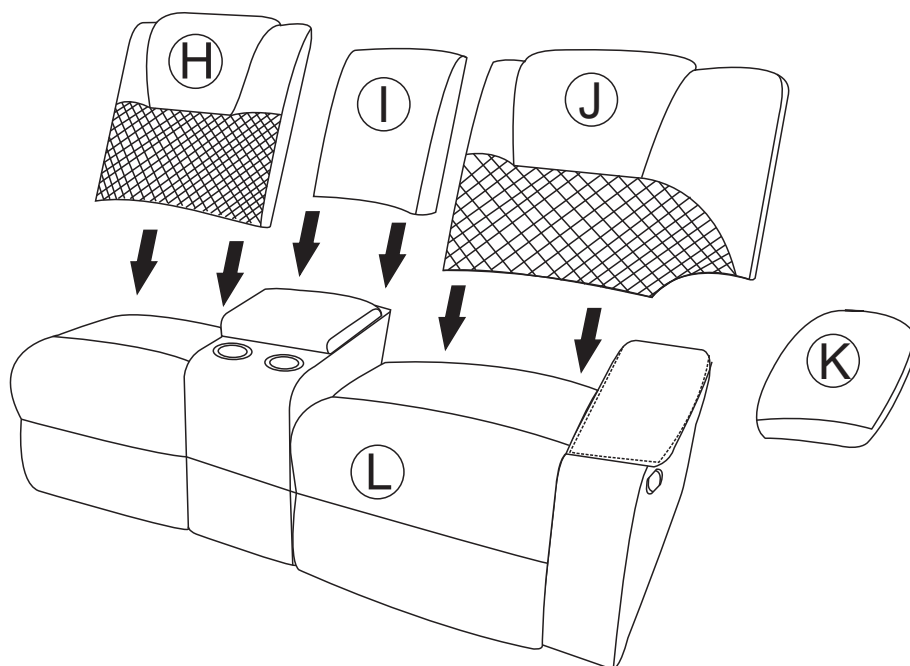

STEP 5:

Connect left and right sides to middle parts using clasps. Ensure brackets are fully inserted and secured.

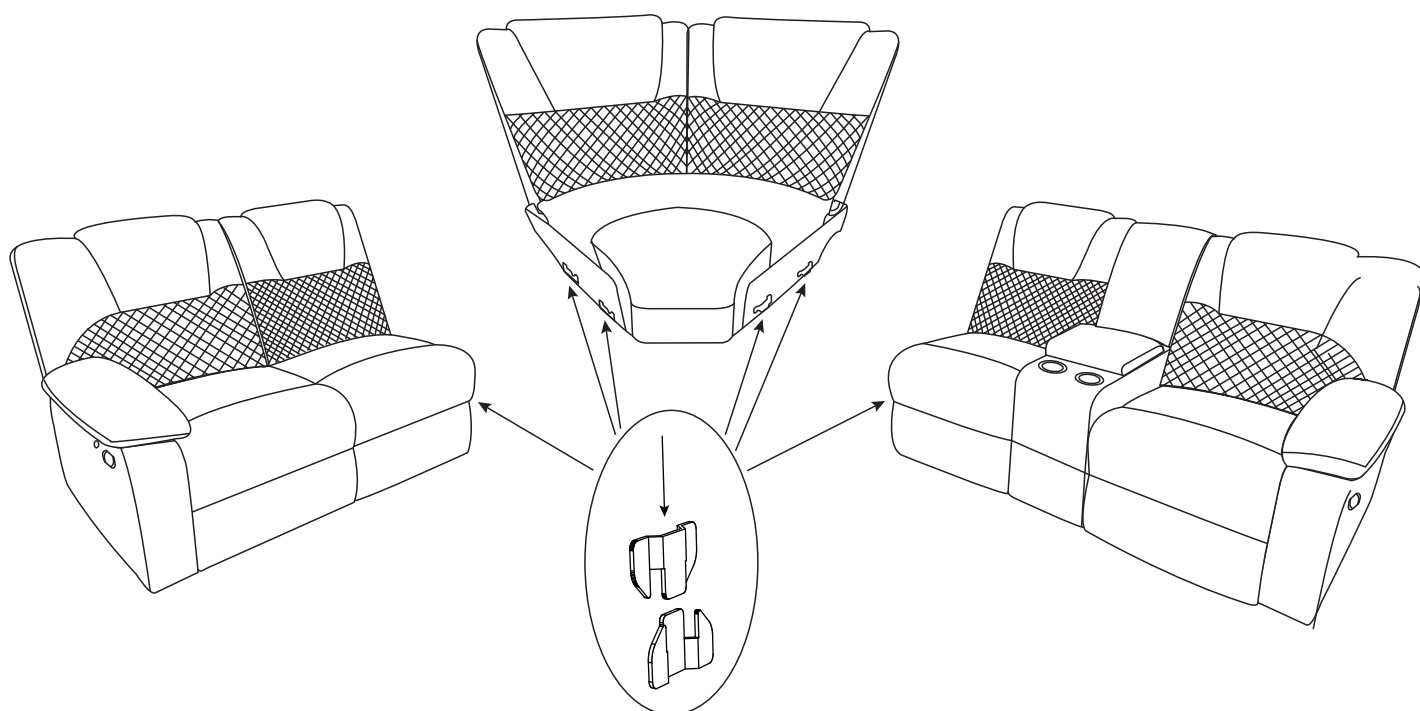

COMPLETE

