

ASSEMBLY INSTRUCTIONS

WF308030-WF308031-WF308032

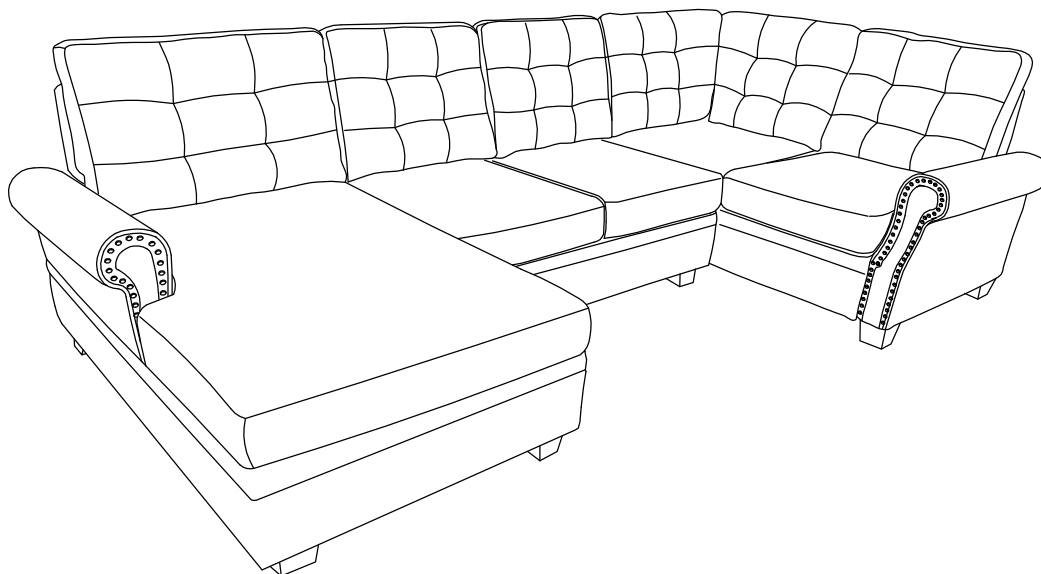

PARTS

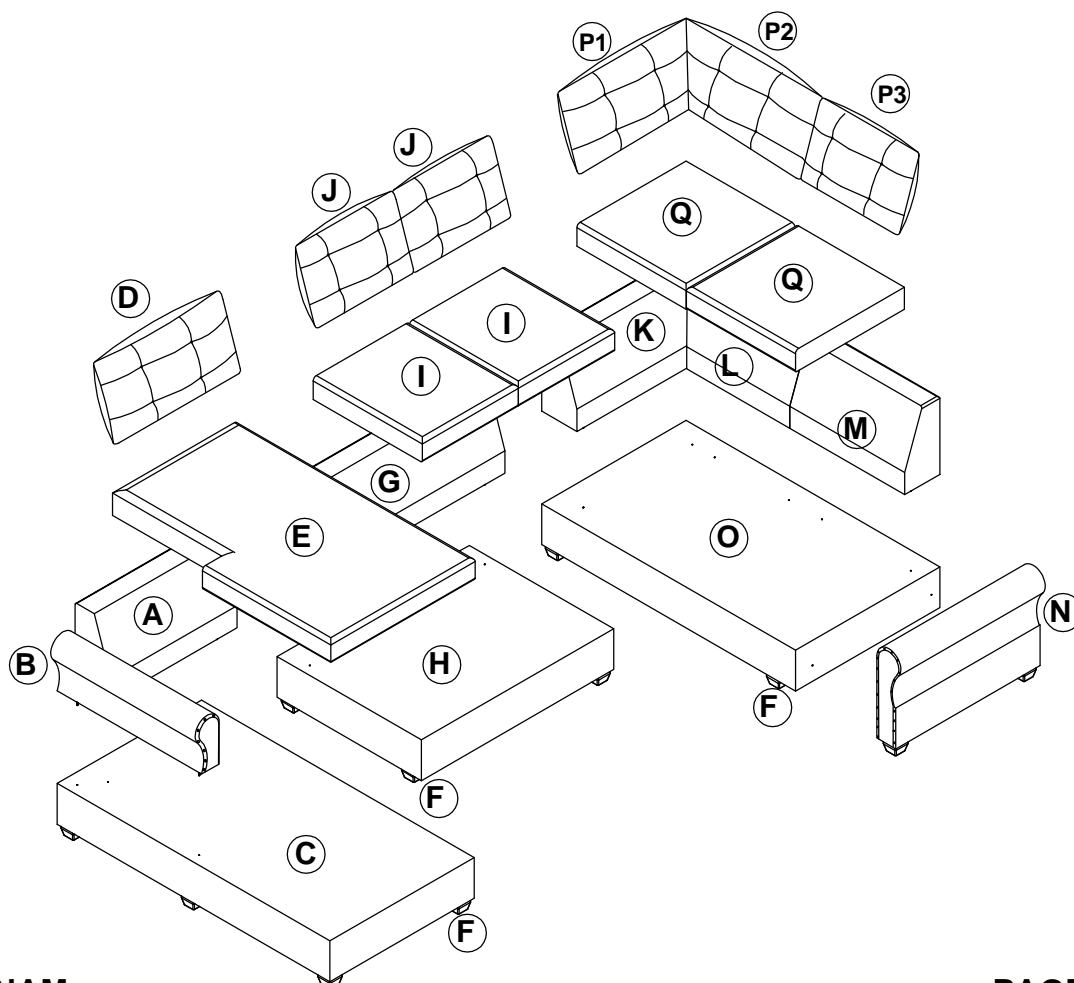

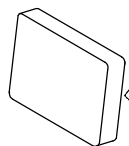
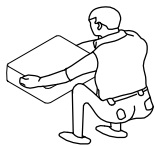
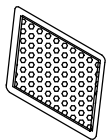

TIPS



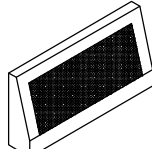
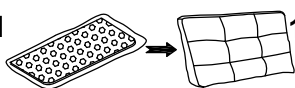
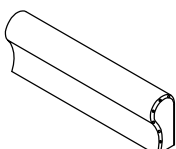
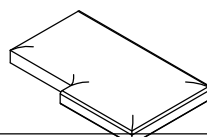
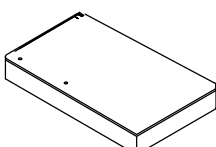

Please allow at least 24 hours for the cushions to recover to its natural state after removing from the package.

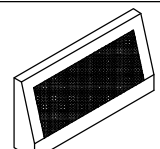
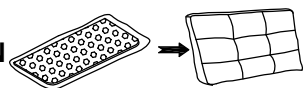
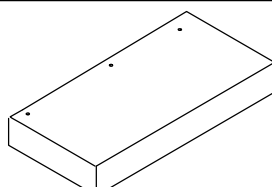

WF308030-COMPONENT LIST

A	CHAISE BACK		1PC	D BACK CUSHION 	1PC
B	LEFT ARM		1PC	E SEAT CUSHION 	1PC
C	CHAISE SEAT		1PC	F LEG 	4PCS

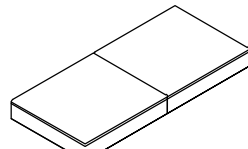

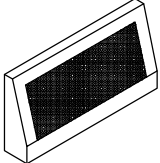
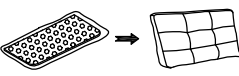
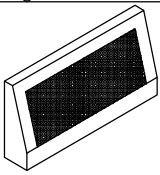
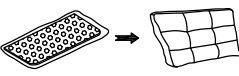
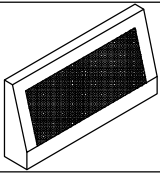
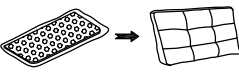
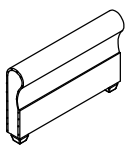
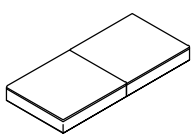
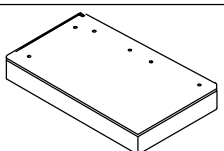

WF308031-COMPONENT LIST

G	SOFA SEAT BACK		1PC	J BACK CUSHION 	2PCS
H	SOFA SEAT SEAT		1PC	F LEG 	4PCS
I	SOFA SEAT SEAT		2PCS		

WF308032-COMPONENT LIST

K	Corner BACK		1PC	P1	BACK CUSHION 	1PC
L	Corner SIDE BACK		1PC	P2	BACK CUSHION 	1PC
M	Corner SIDE BACK		1PC	P3	BACK CUSHION 	1PC
N	RIGHT ARM		1PC	Q	SEAT CUSHION 	2PCS
O	Corner SEAT		1PC	F	LEG 	4PCS

HARDWARE WF308030-WF308031-WF308032

1	HEX NUT		17PCS	3	FLAT WASHER 	17PCS
2	THREADED BOLT		17PCS	4	WRENCH 	1PC

Step 1:

Remove the hardware and the leg box from packet.
Place all parts on a clean, smooth surface

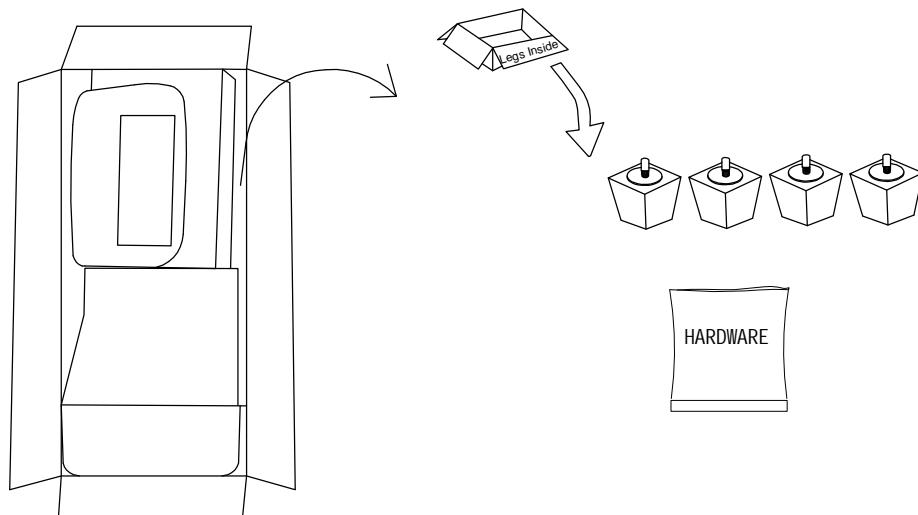

STEP 2

Manually screw 2 to A as shown.

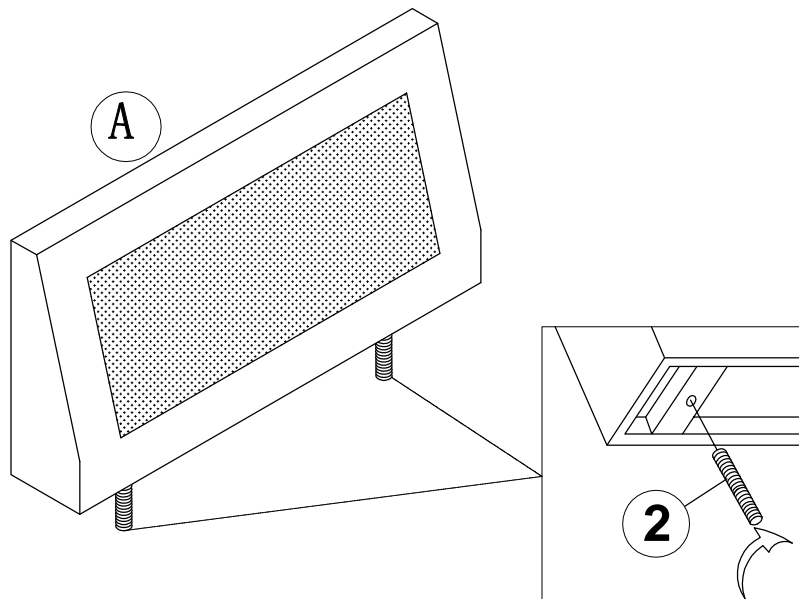

STEP 3

Manually screw 2 to B as shown.

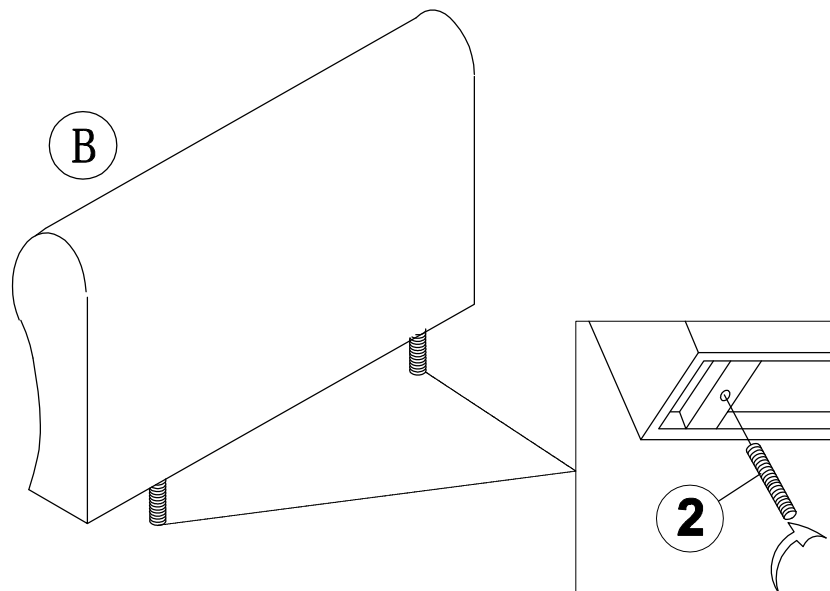

STEP 4

Align the backrest A and Armrest B in C.

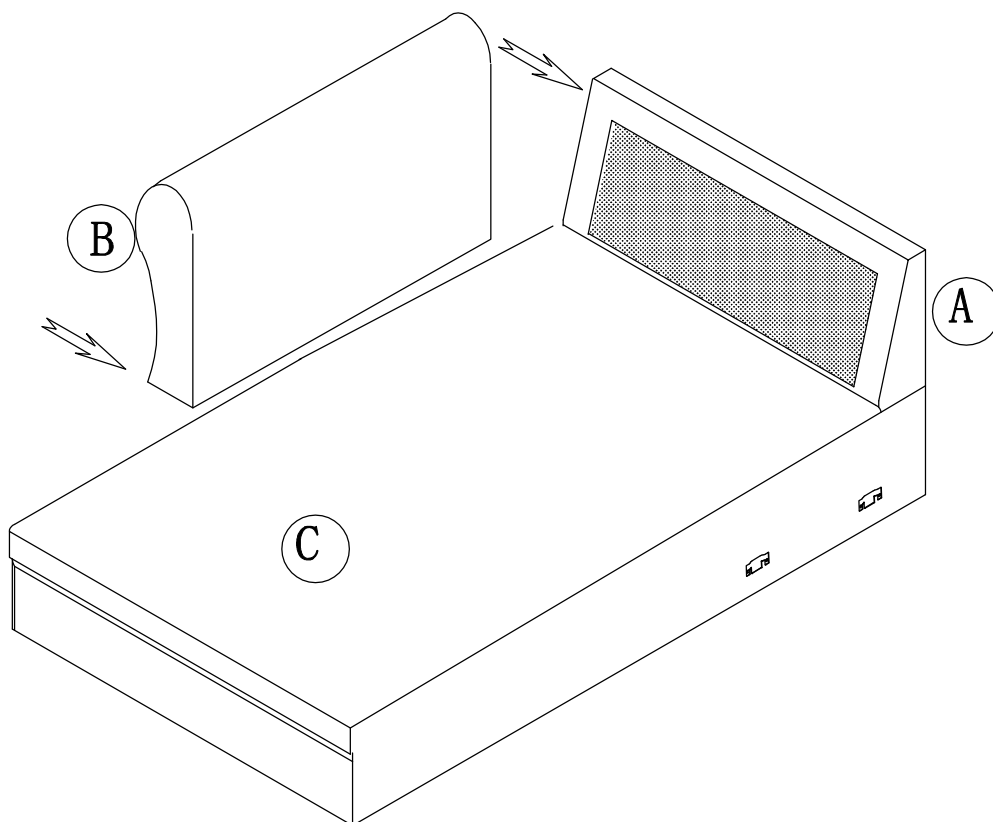

STEP 5

Fix it by using 2, 3, 1 & 4.

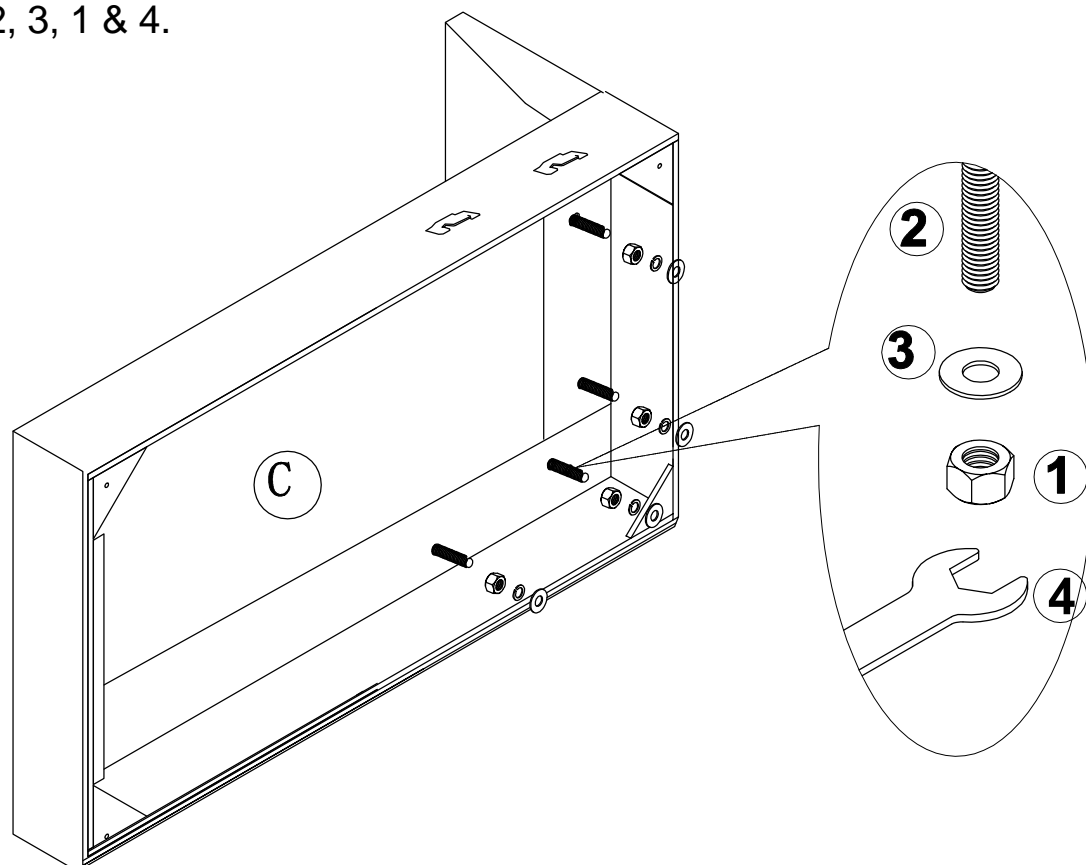

STEP 6

Manually legs F x 4 to C as shown.

▲ Please remove the protective cap on the tip of thread before assembling.

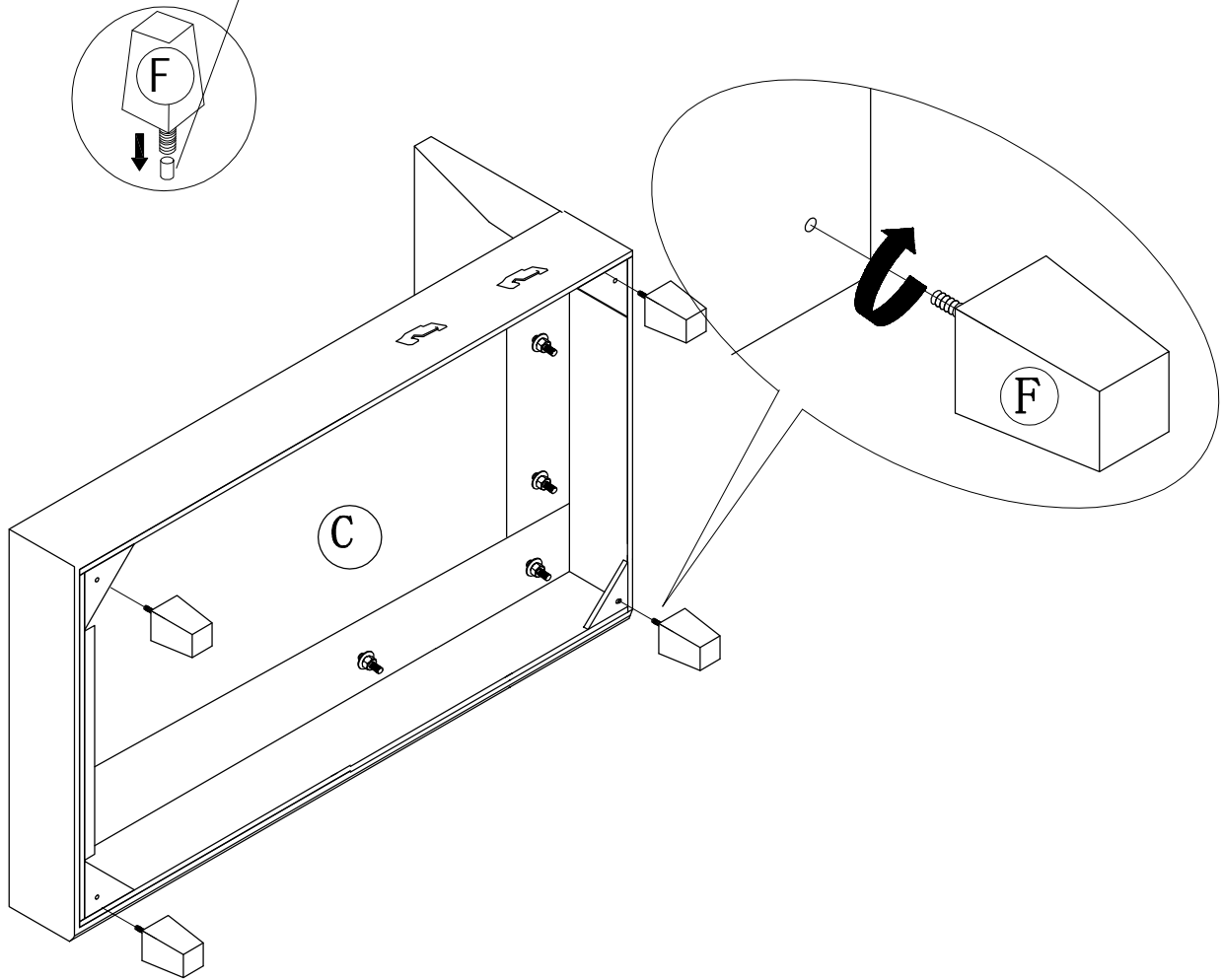

STEP 7

BOTTOM VIEW

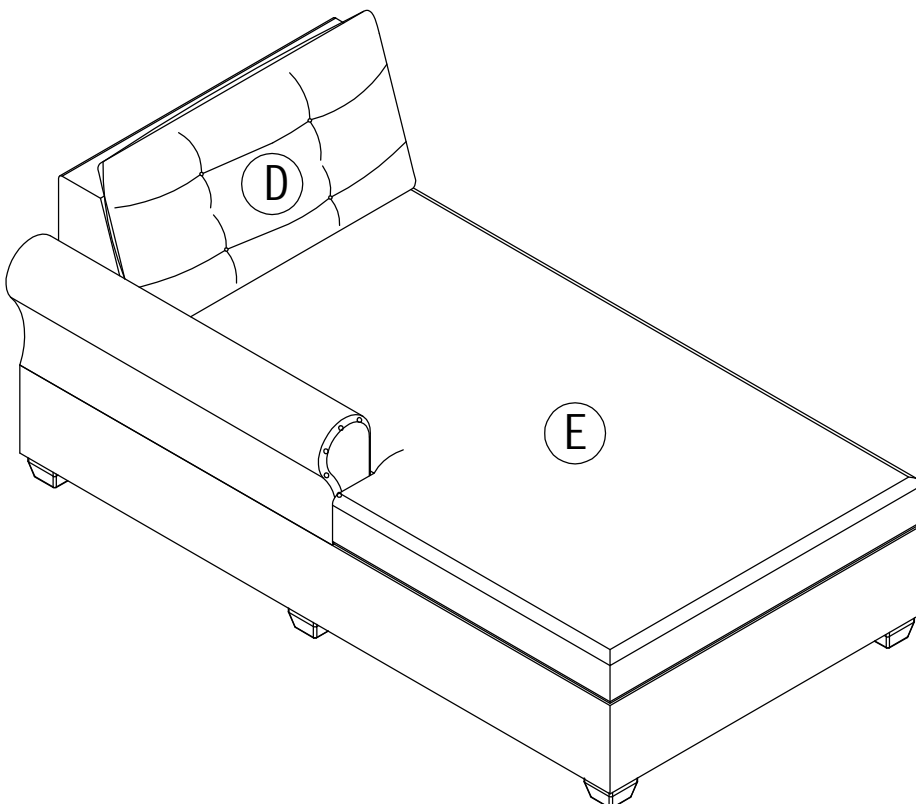

STEP 8

Manually screw 2 to G as shown.

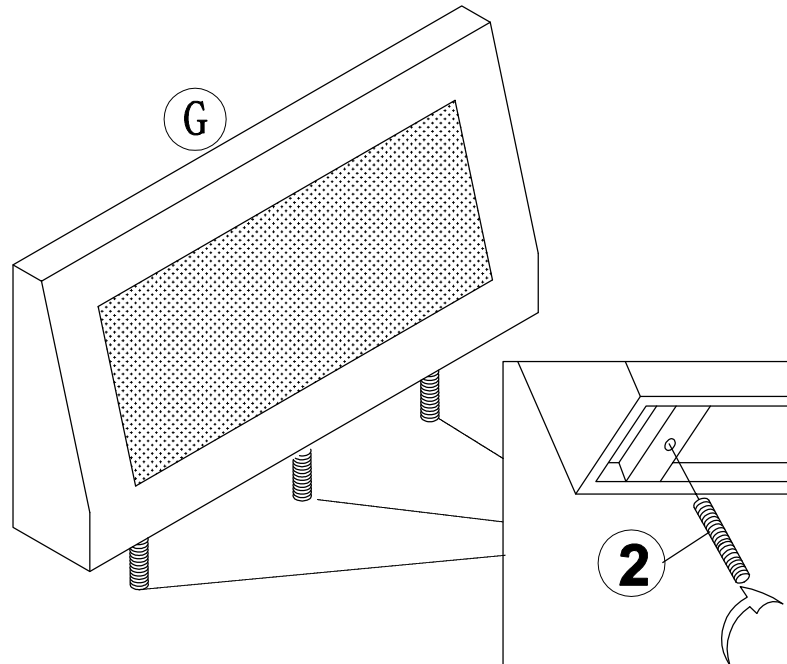

STEP 9

Align the backrest G in H.

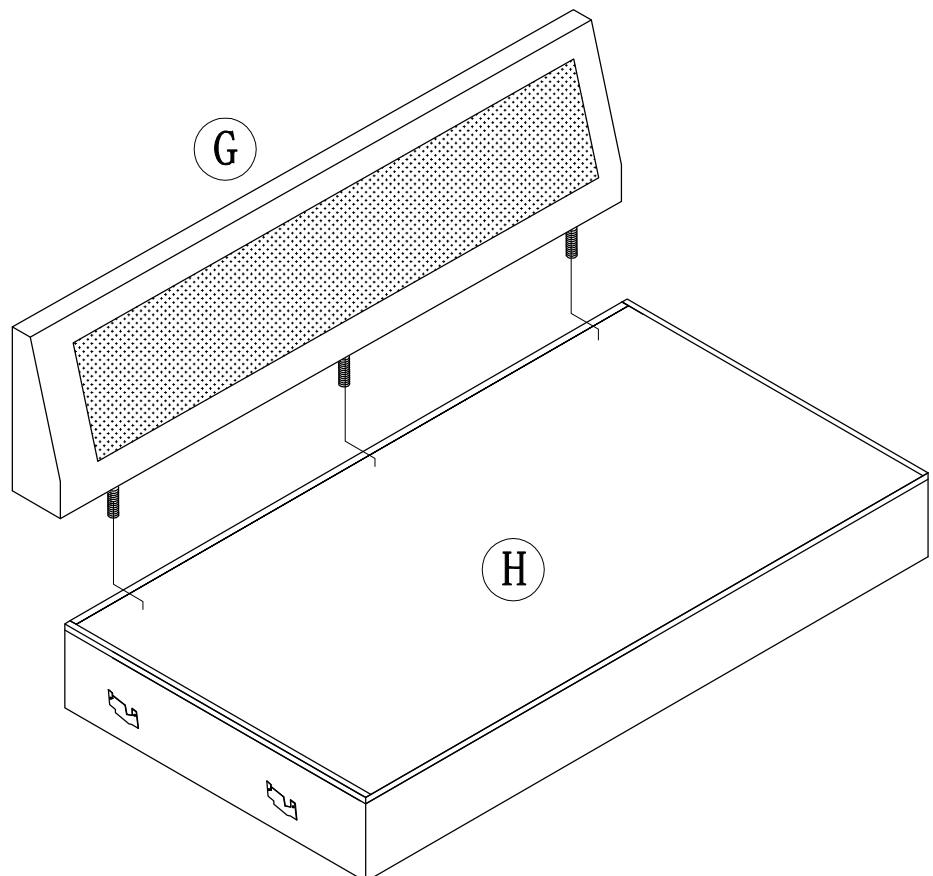

STEP 10

Fix it by using 2, 3, 1 & 4.

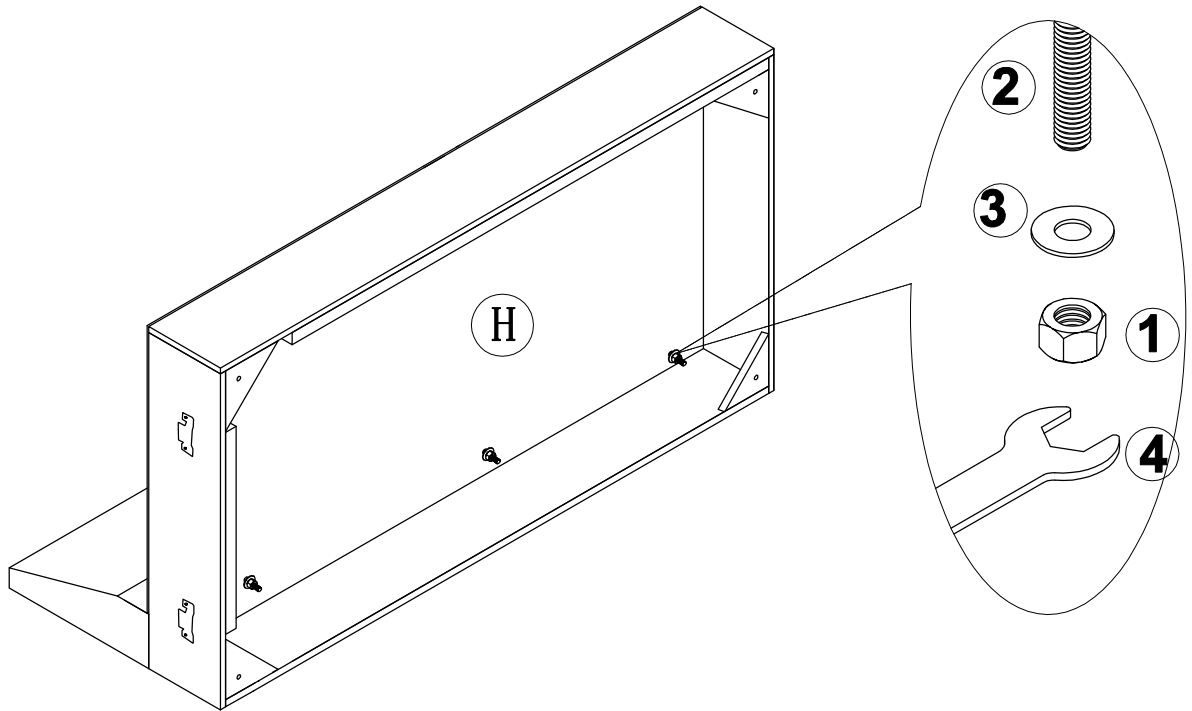

STEP 11

Manually legs F x 4 to H as shown.

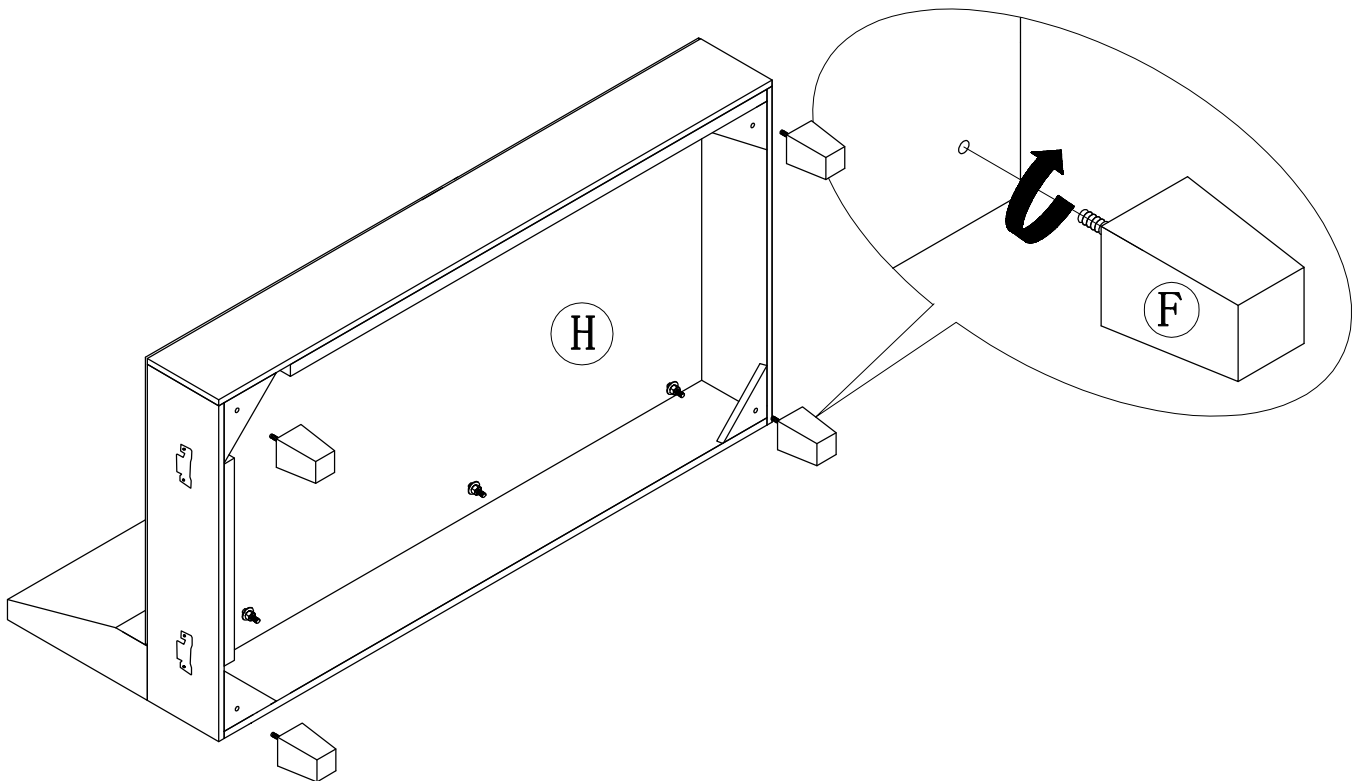

STEP 12

BOTTOM VIEW

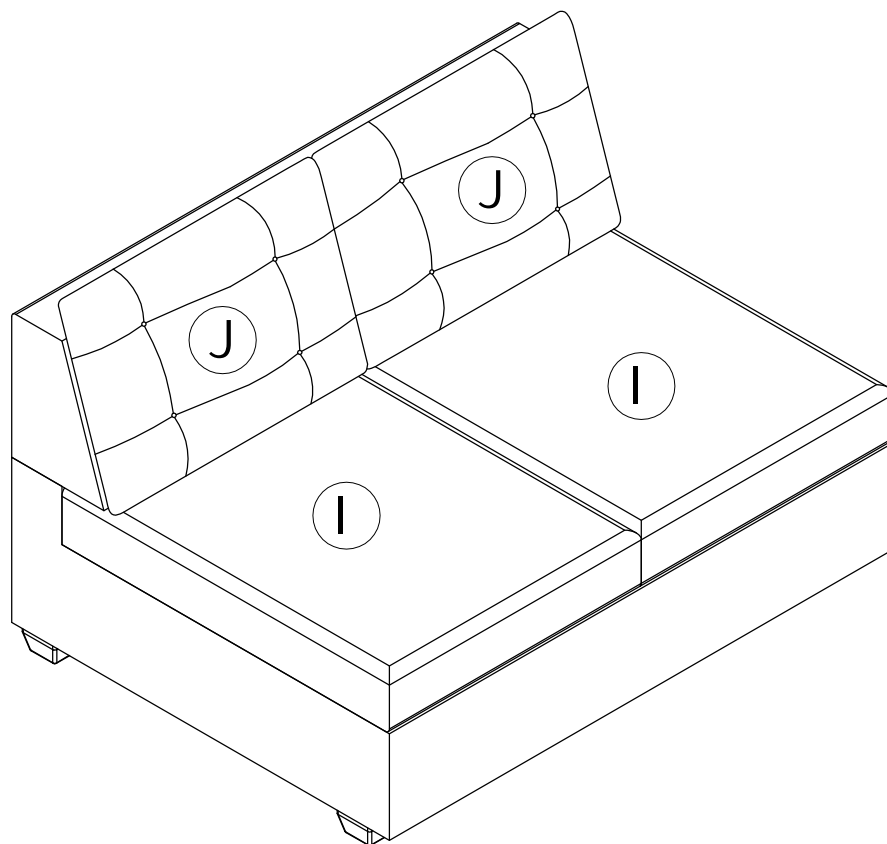

STEP 13

Manually screw 2 to K, L and M as shown.

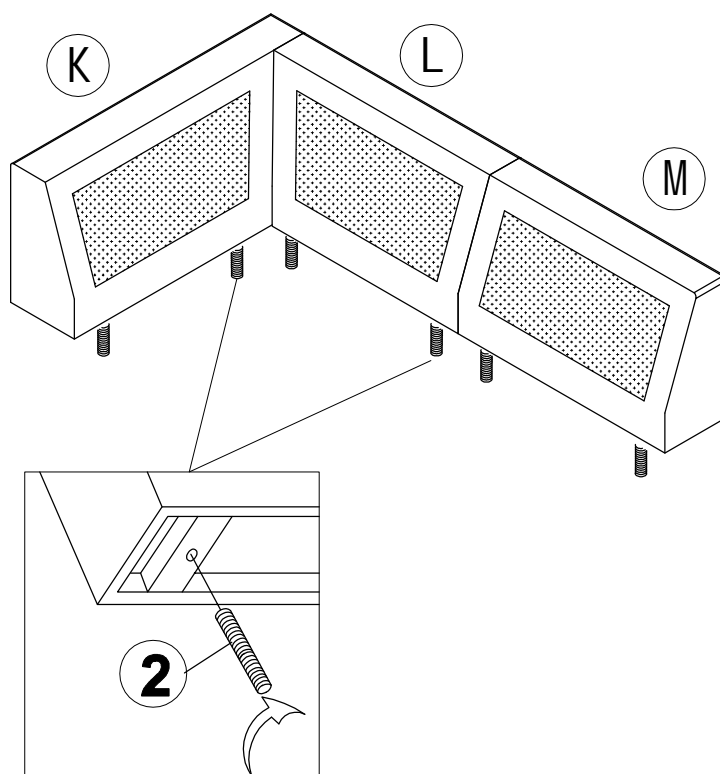

STEP 14

Align the backrest K, L and M in O.

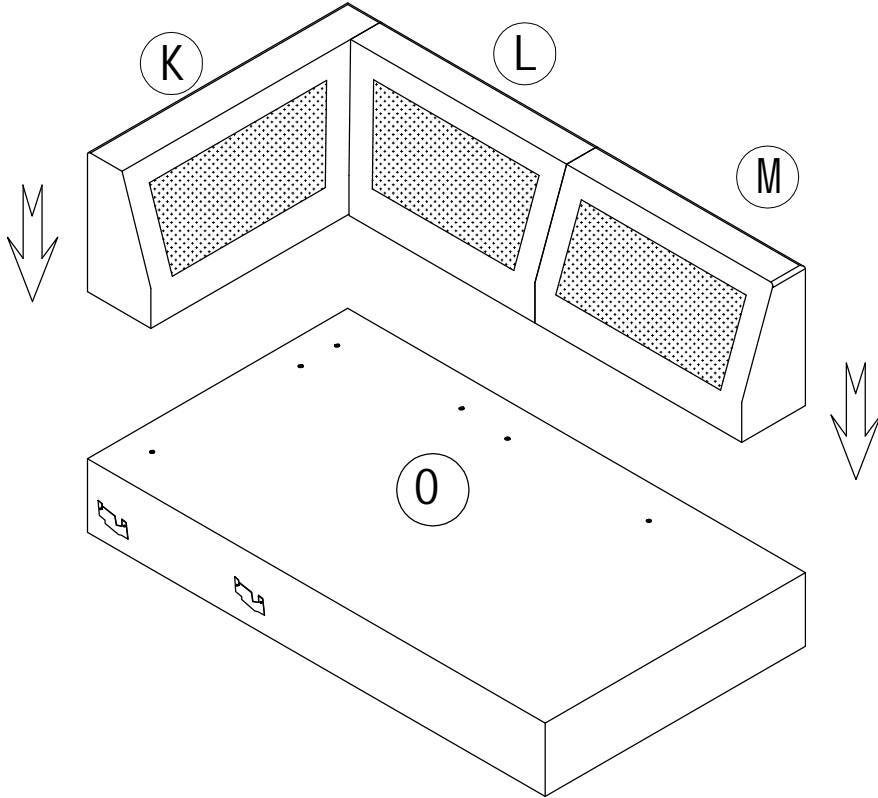

STEP 15

Manually screw 2 to N and align the Armrest to O as shown.

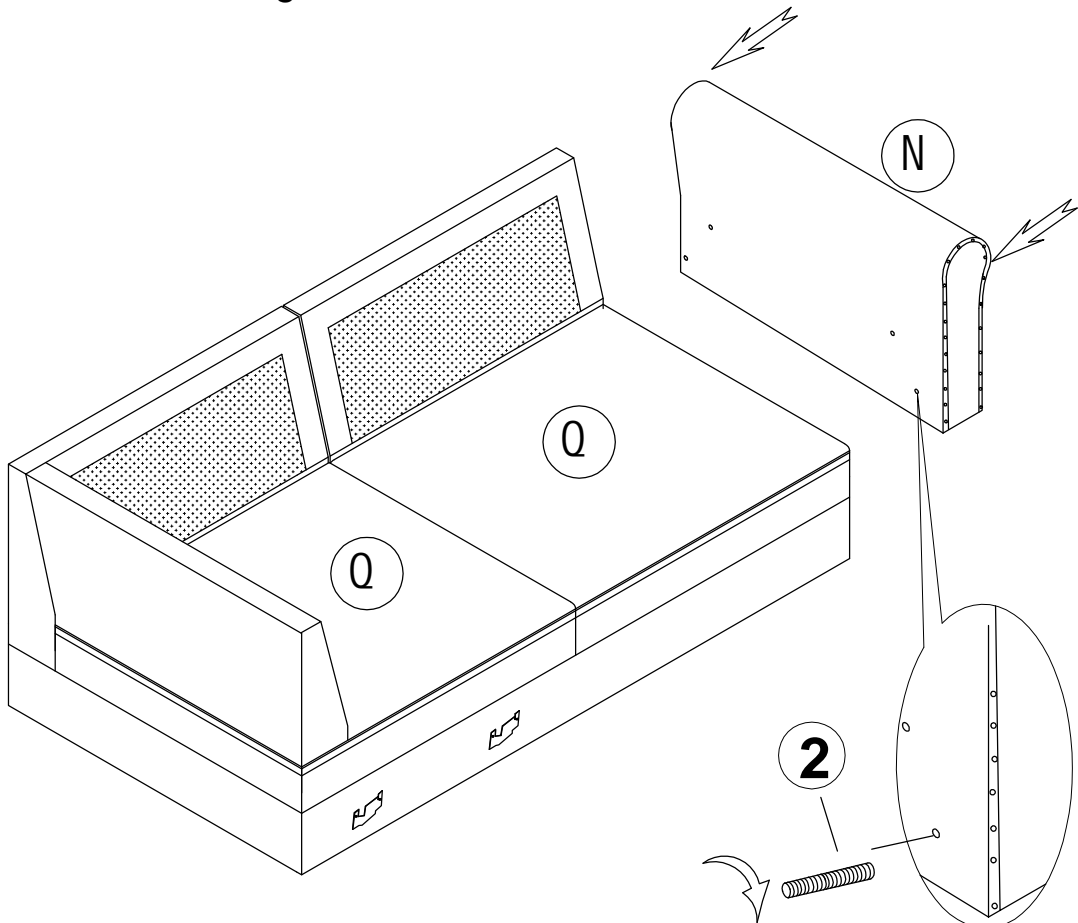

STEP 16

Fix it by using 2, 3, 1 & 4.

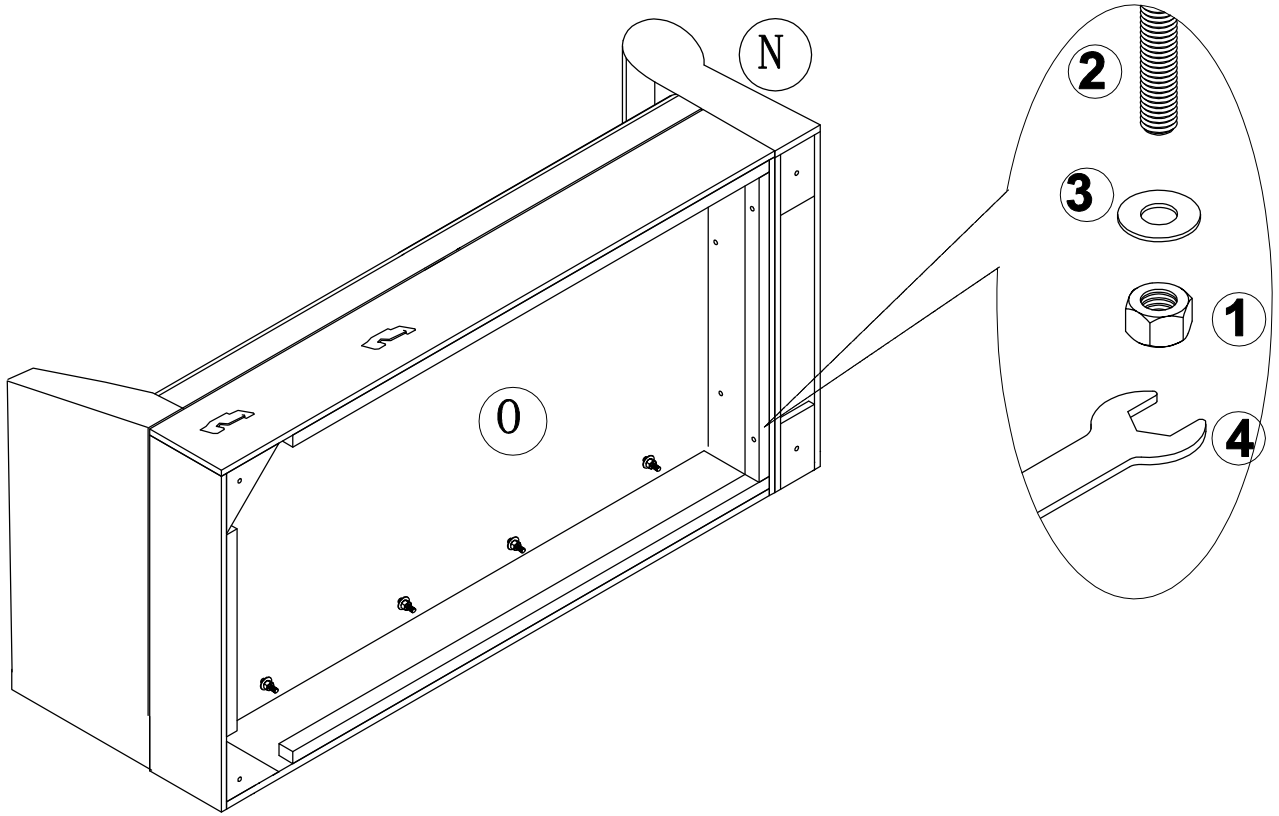

STEP 17

Manually legs F x 4 to O as shown.

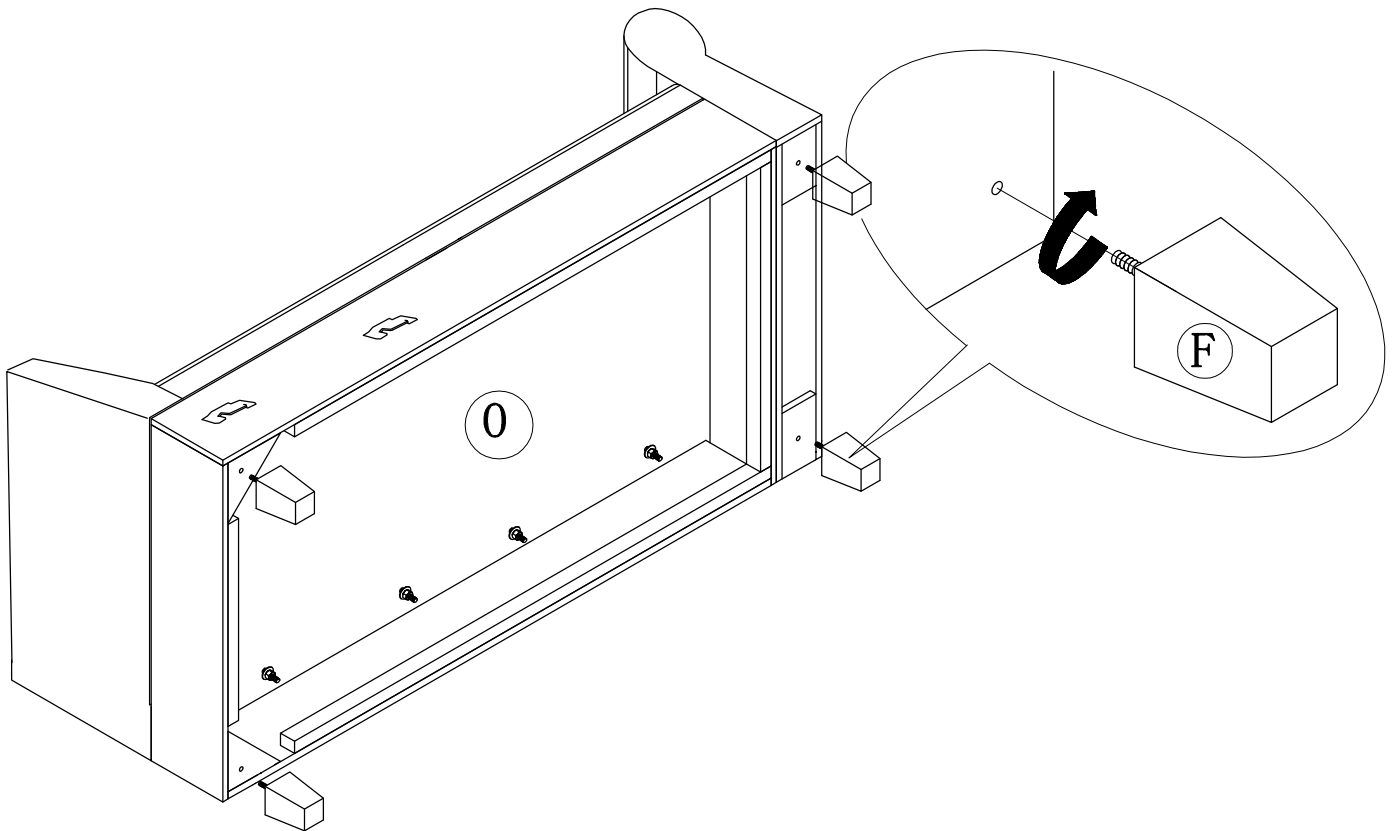

STEP 18

BOTTOM VIEW

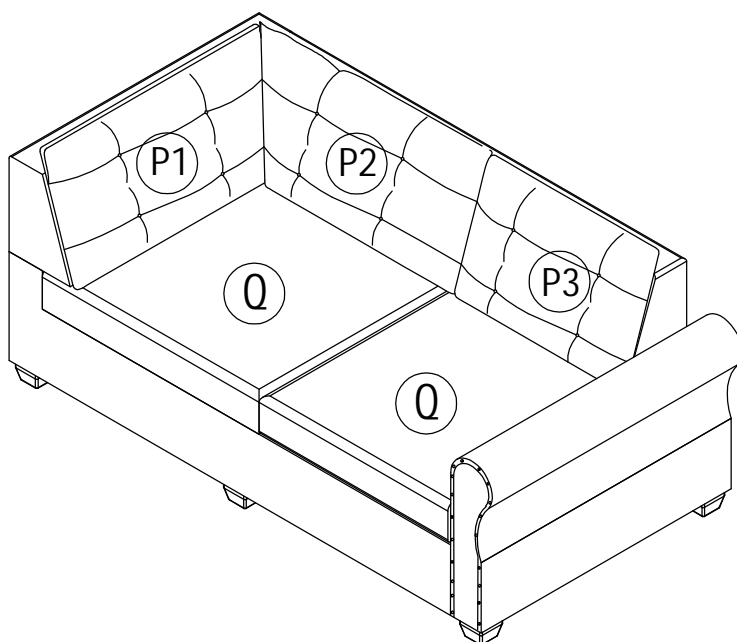

STEP 19

Joint the connector of Chaise, Sofa and Corner to fix together.

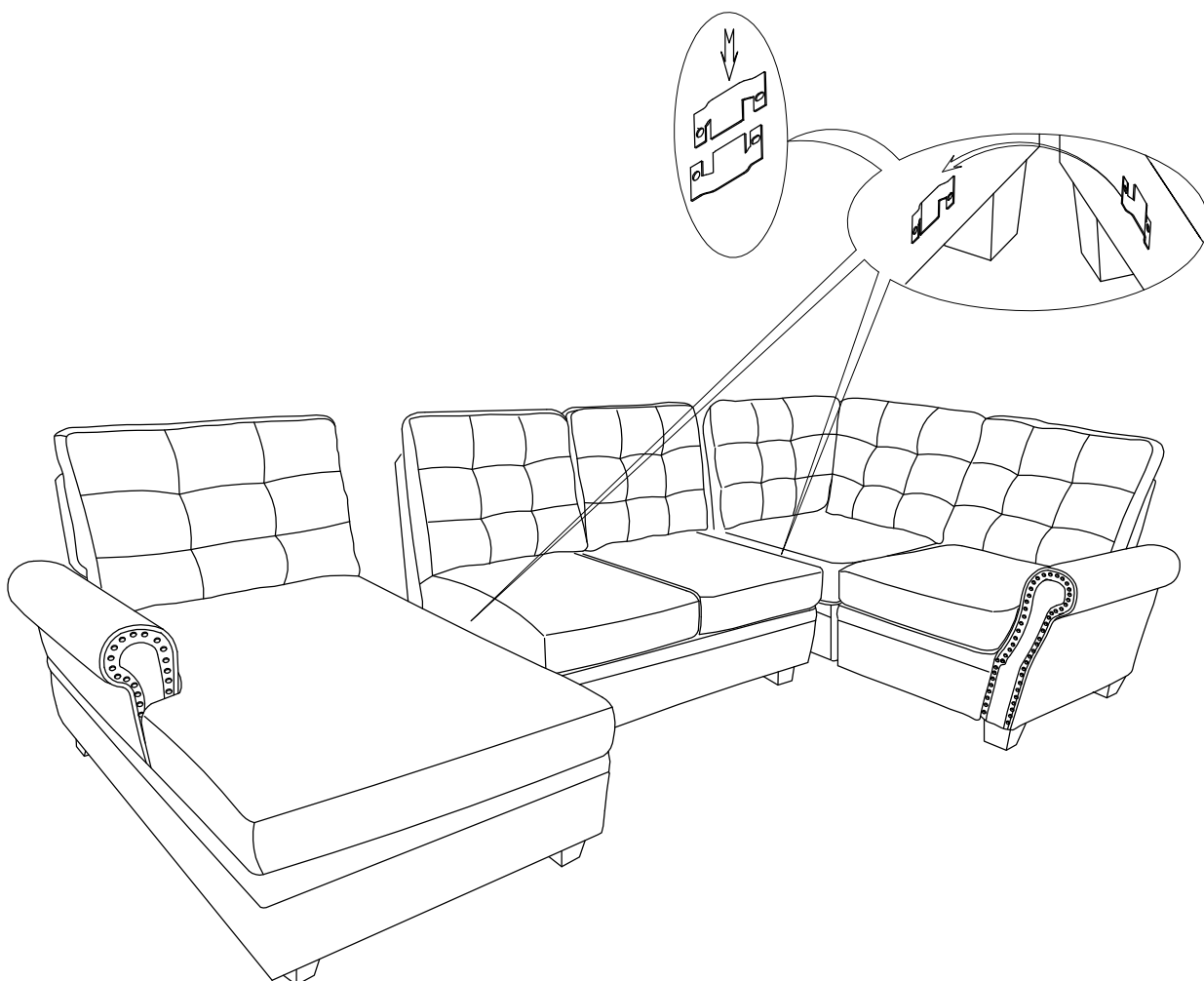

BOTTOM VIEW

