

ASSEMBLY INSTRUCTIONS

ITEM NO . WF304306/07/08

Your chair comes packaged in one box. Carefully remove all of components from the packaging and set aside for assembly.

CAUTION:
DO NOT use any sharp objects to open plastic wrapped components as damage to product or components may result.

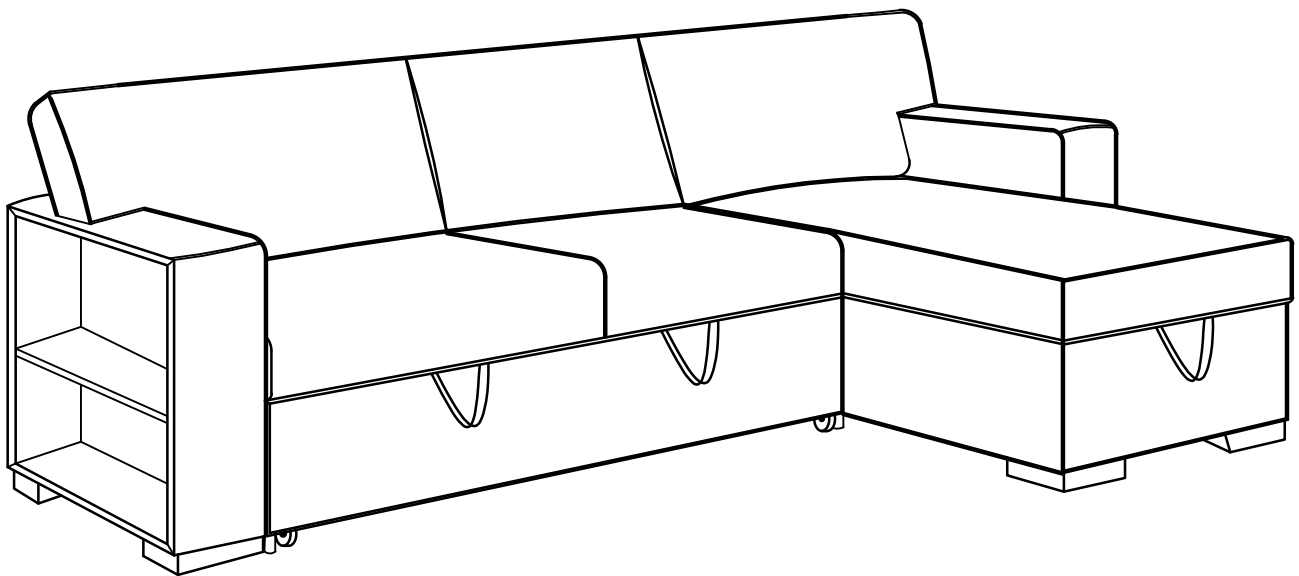



IMPORTANT NOTE:

- ① PLACE ALL PARTS ON A CLEAN AND SMOOTH SURFACE SUCH AS A RUG OR CARPET TO AVOID THE PARTS FROM BEING SCRATCHED.
- ② BEFORE YOU BEGIN, KINDLY FOLLOW THE ASSEMBLY INSTRUCTIONS STEP BY STEP.
- ③ DO NOT TIGHTEN ALL SCREWS AND BOLTS UNTIL THE CHAIR IS FULLY SET-UP.

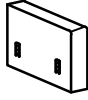

PARTS LIST - WF304308

PART	DRAWING	DESCRIPTION	QTY	PART	DRAWING	DESCRIPTION	QTY
A		LEFT Arm	1	B		RIGHT Arm	1



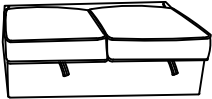

PARTS LIST - WF304307

PART	DRAWING	DESCRIPTION	QTY	PART	DRAWING	DESCRIPTION	QTY
C		Chaise	1	D		Backrest	1
				E		Backrest	2

PARTS LIST - WF304306

PART	DRAWING	DESCRIPTION	QTY	PART	DRAWING	DESCRIPTION	QTY
F		Love seat	1	G		RAF Back Cushion	1
H		LAF Back Cushion	1				

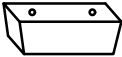
HARDWARE LIST - WF304306

PART	DRAWING	DESCRIPTION	QTY	PART	DRAWING	DESCRIPTION	QTY
I		Screw M8 x 55mm	18	J		Roller	4
K		Legs	6	L		Screw #8 x 25mm	16
M		Legs	6				

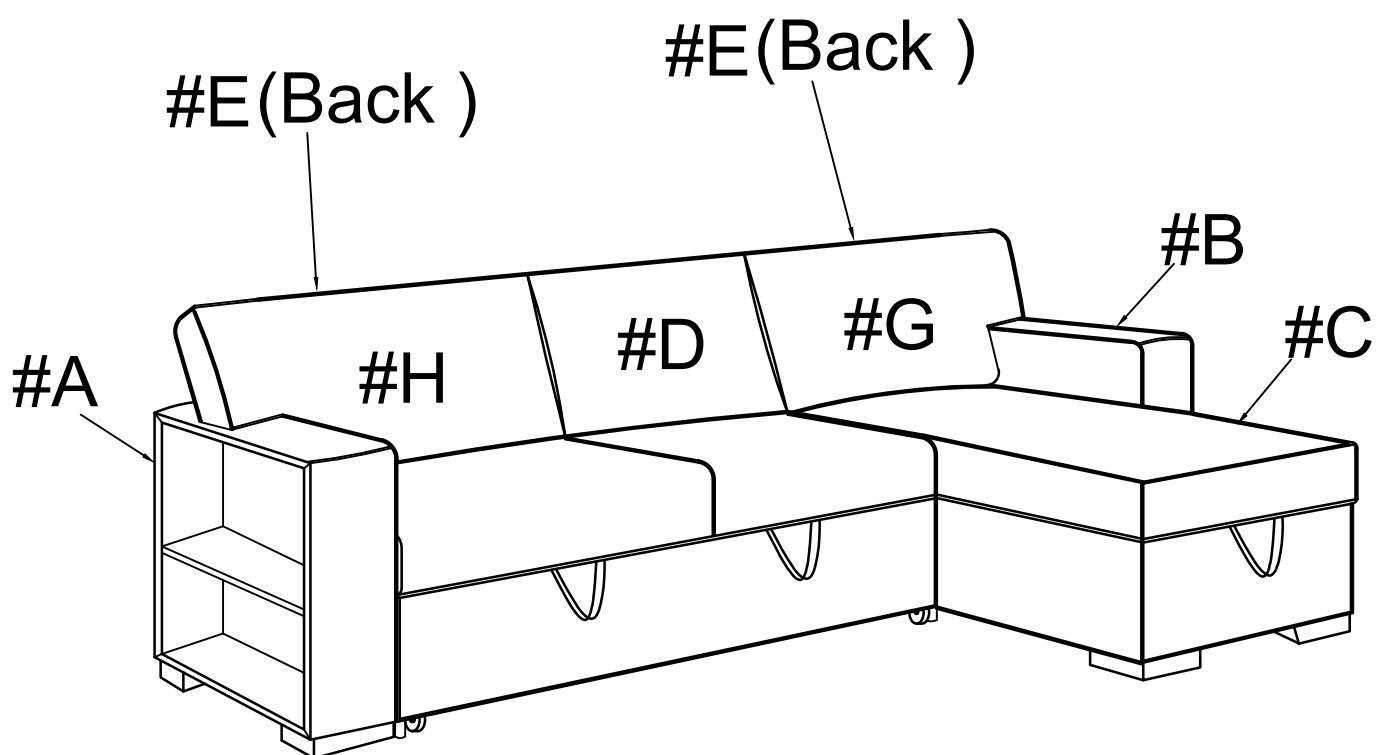

THE PARTS ARE LOCATED INSIDE THE BOX AS BELOW:

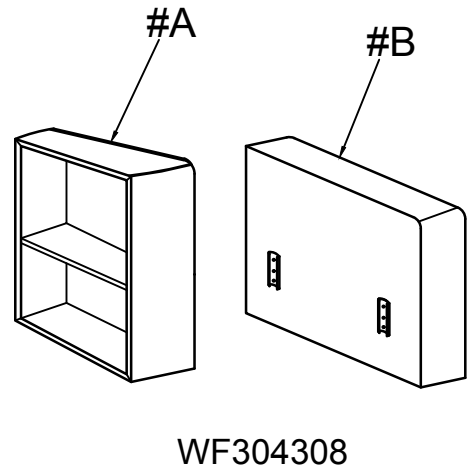
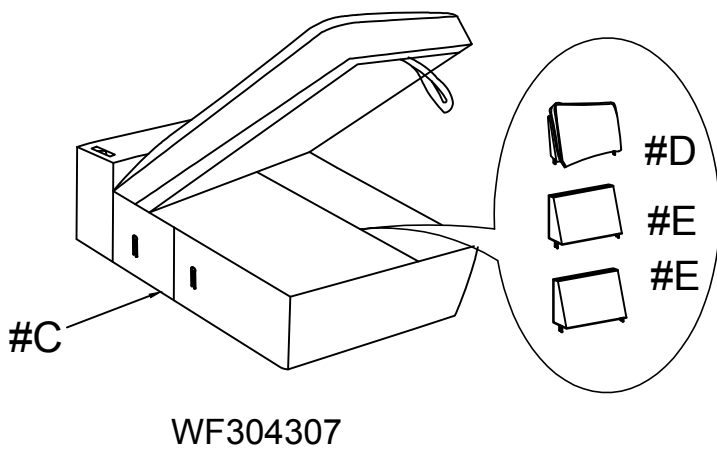
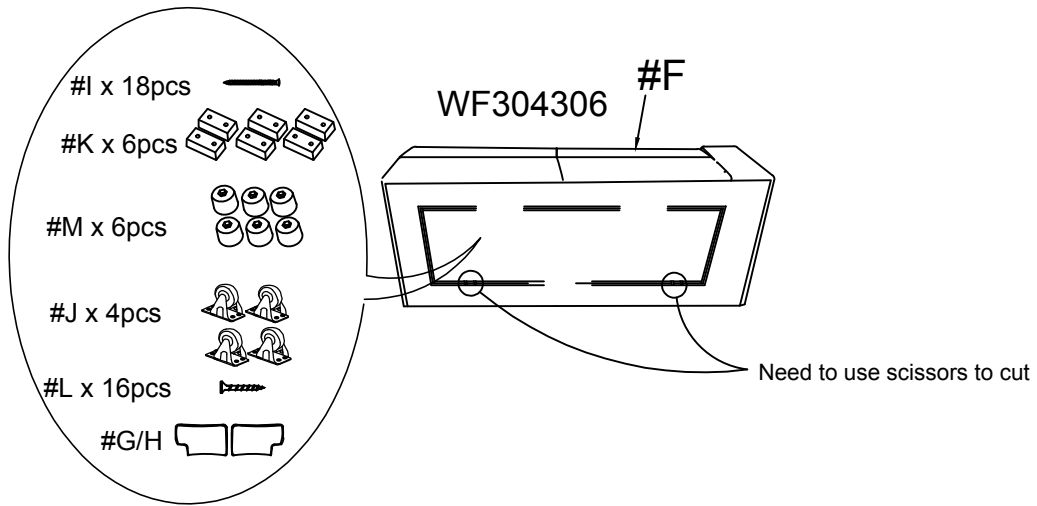

STEP 1

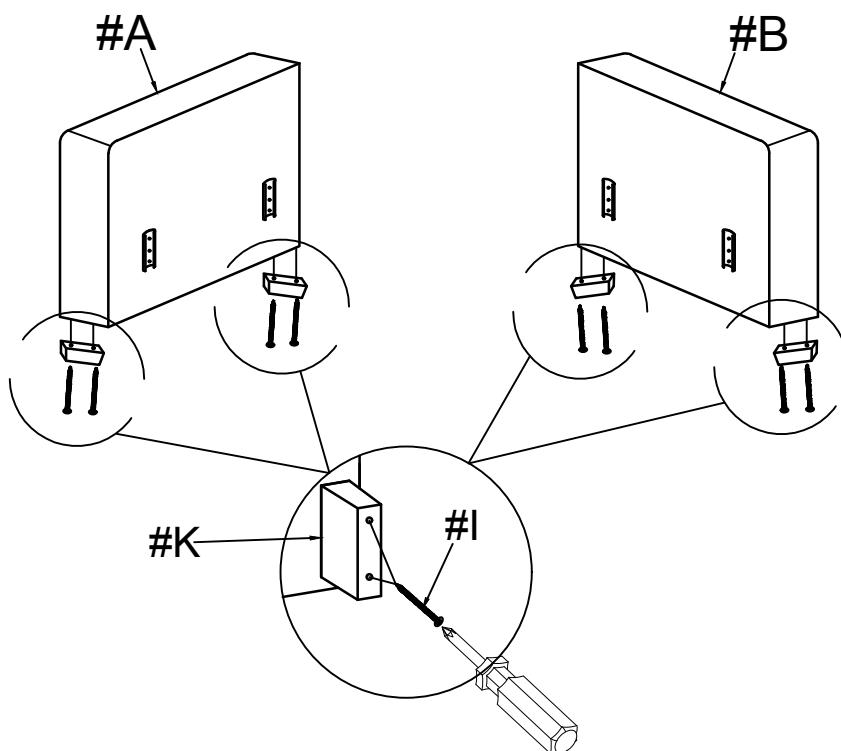

STEP 2

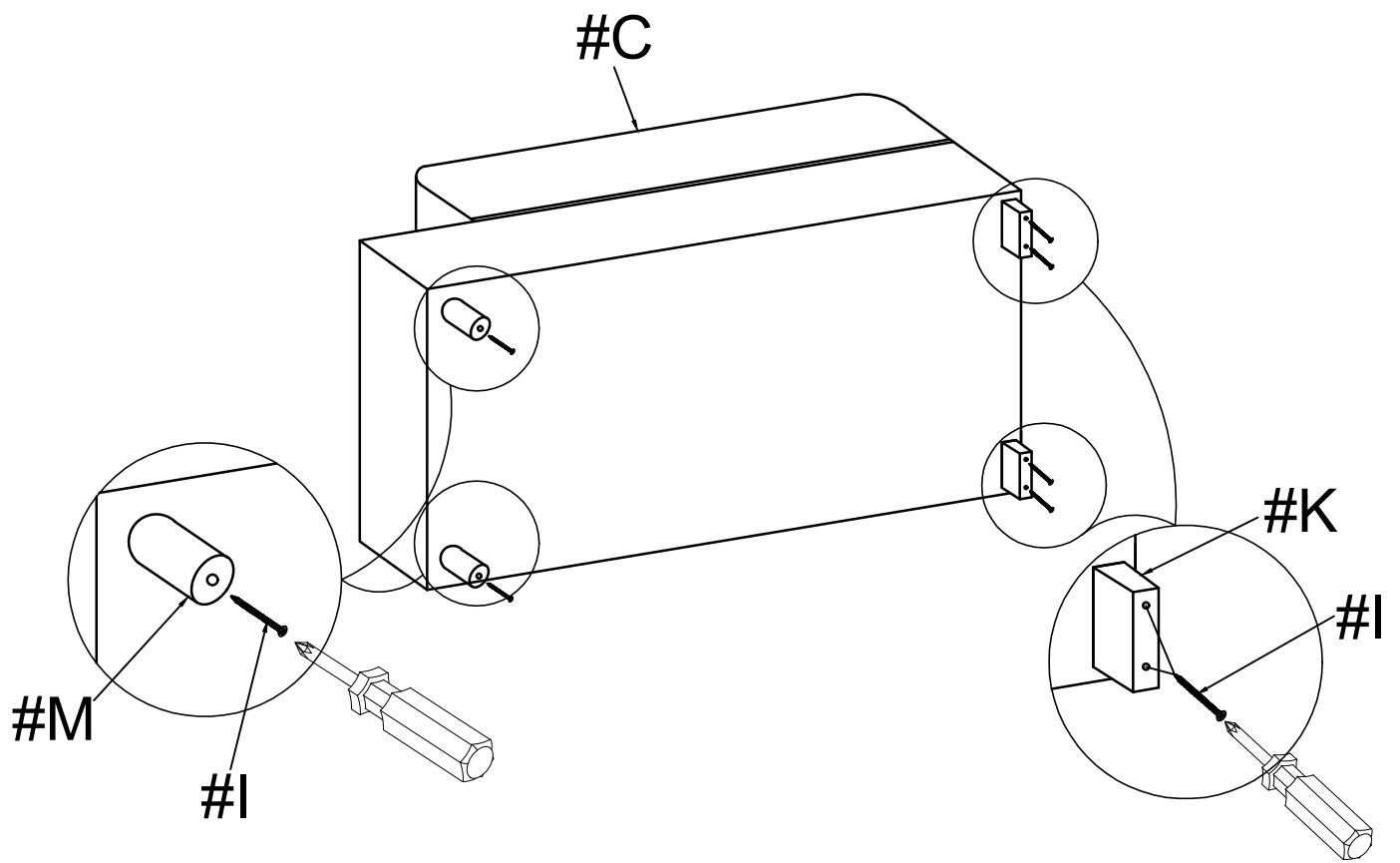

STEP 3

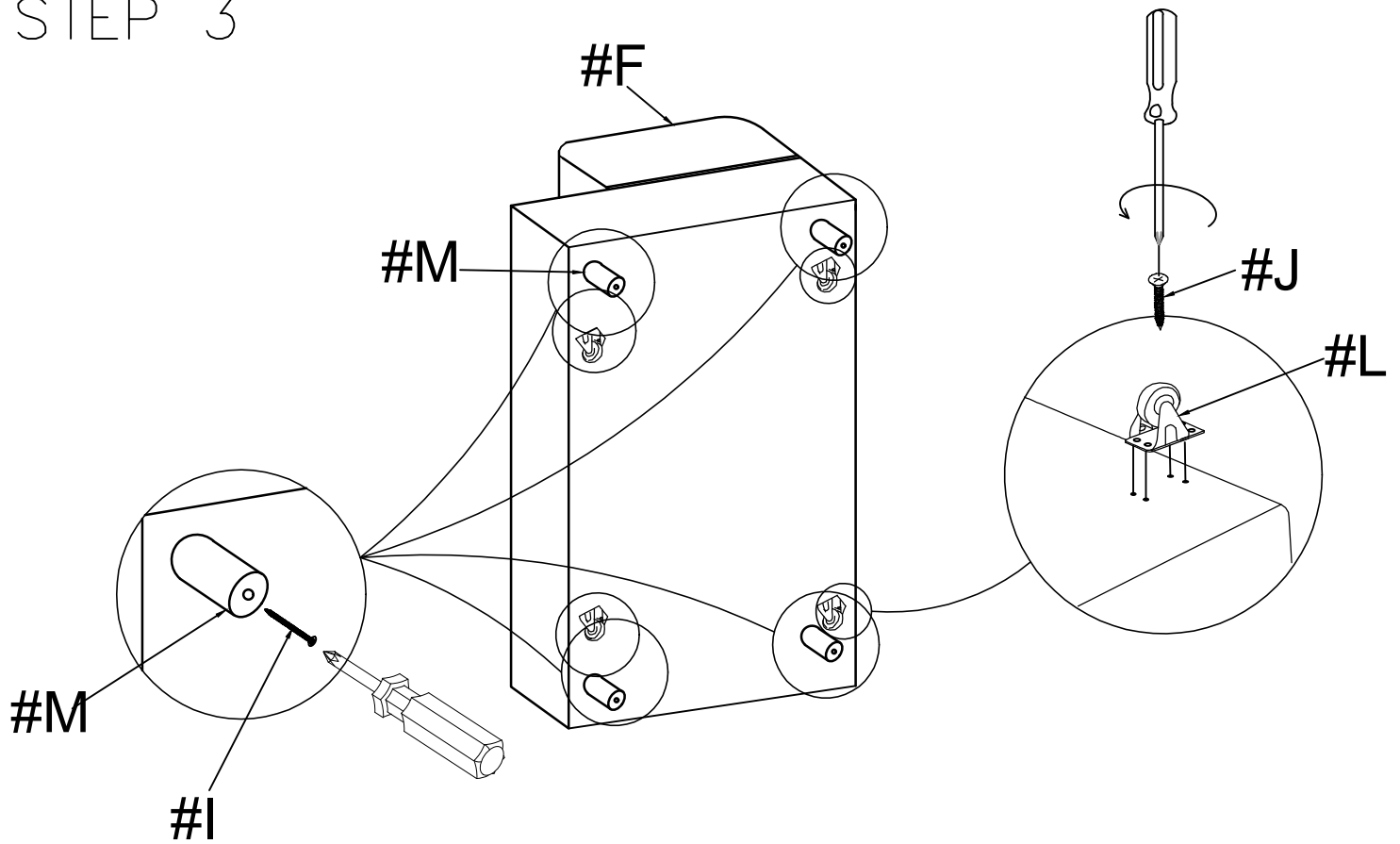

STEP 4

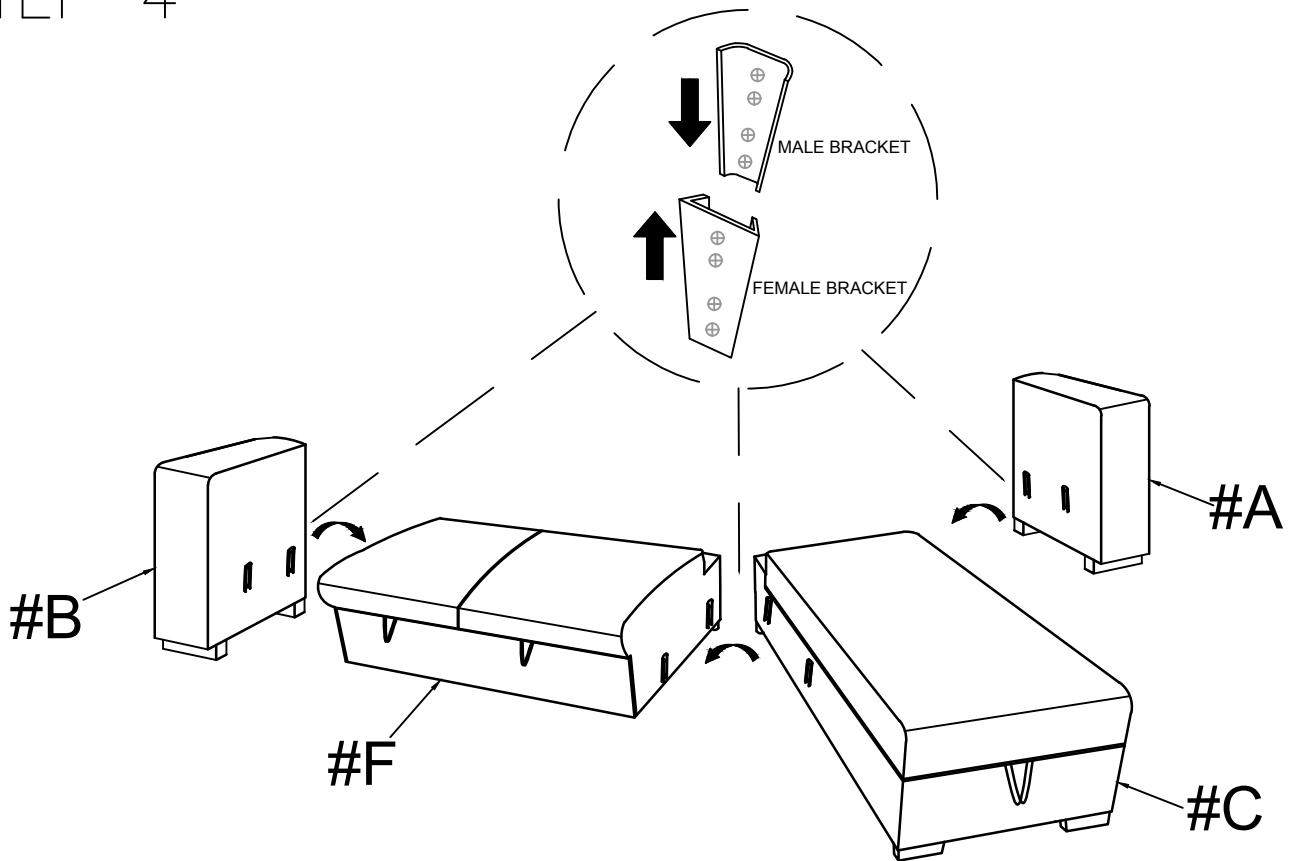

STEP 5

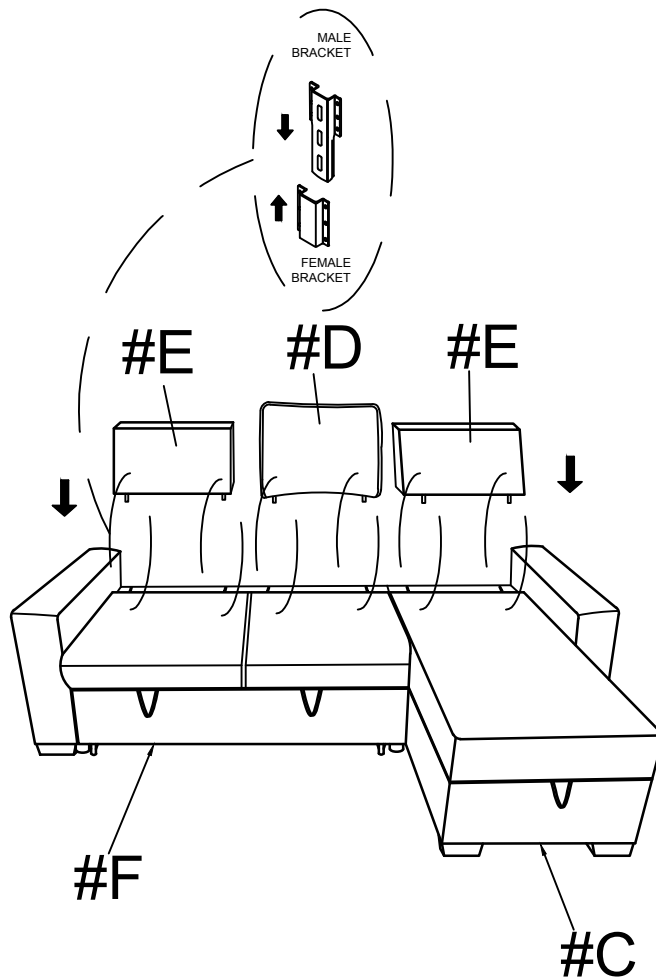

STEP 6

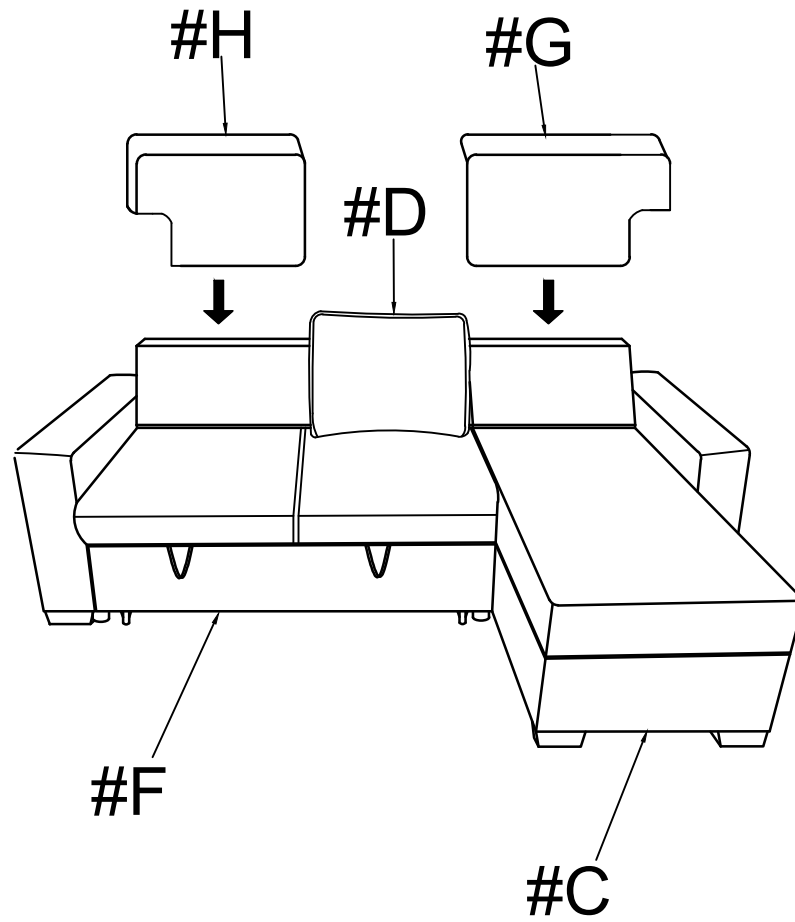

STEP 7

ARMREST CAN BE EXCHANGE IN BETWEEN

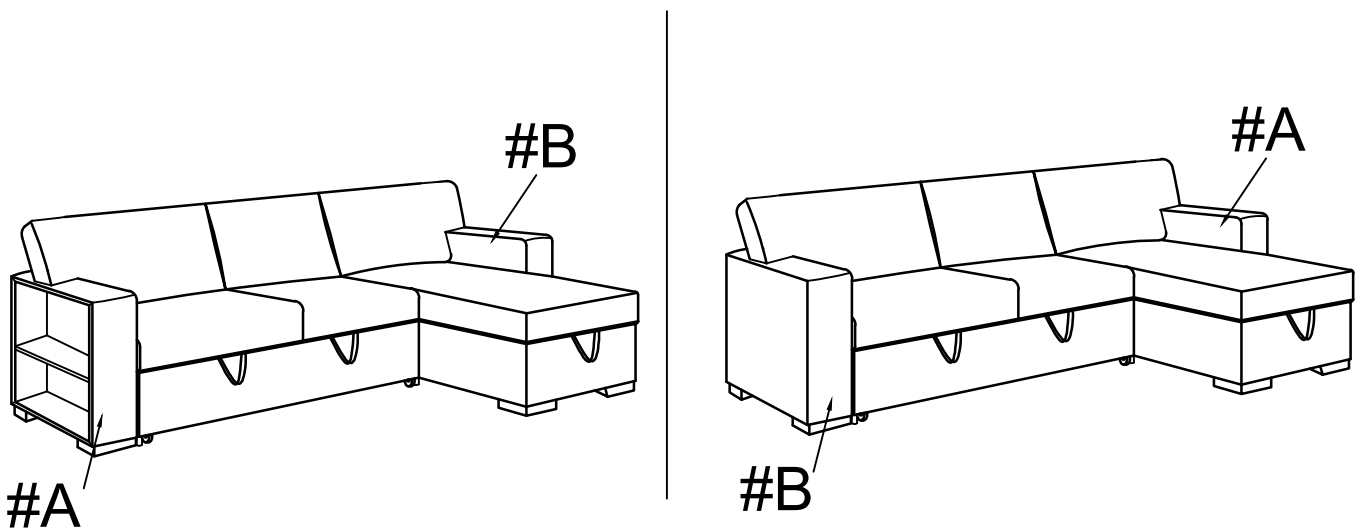

STEP 8

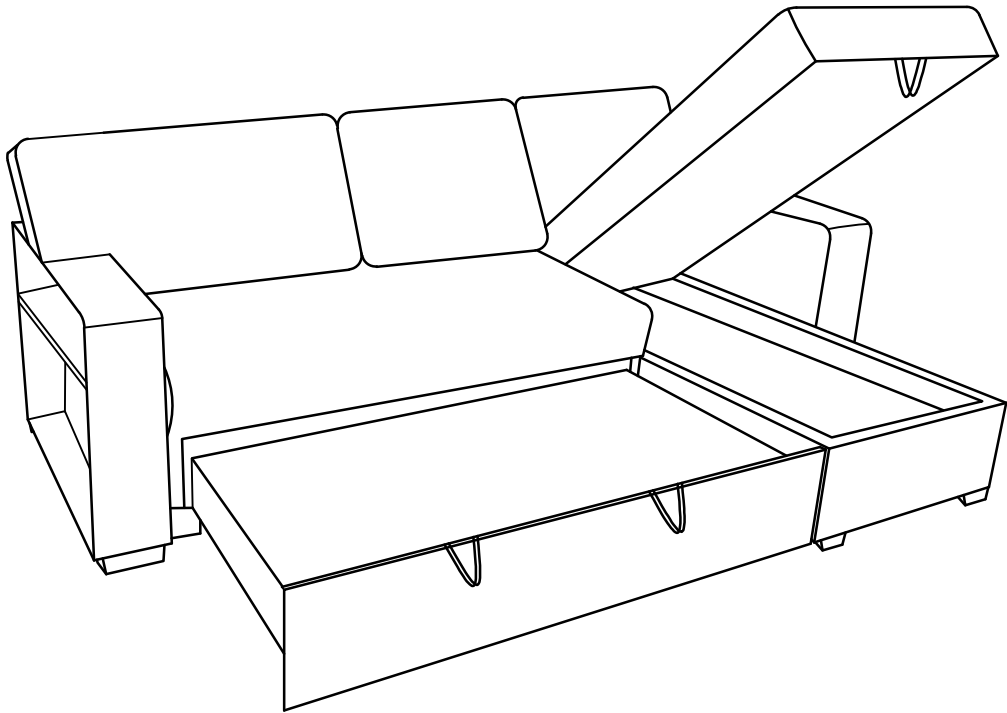

STEP 9

