

ASSEMBLY INSTRUCTION

ITEM: WF284017 - OTTOMAN
WF284016 - CHAISE
WF284015 - SOFA

Please choose the CHAISE will be on the LEFT or RIGHT hand side

CHAISE ON LEFT

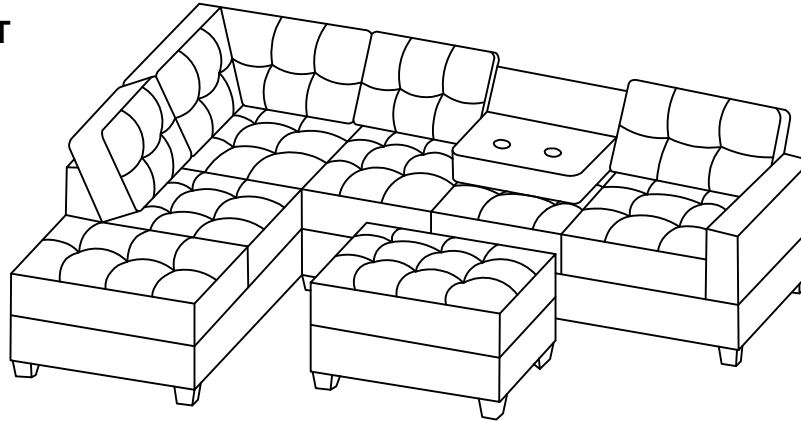



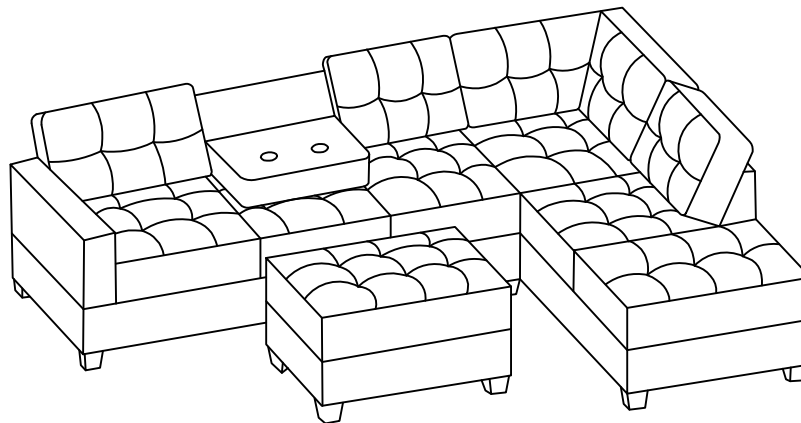



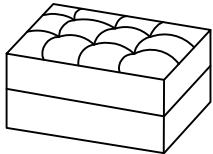
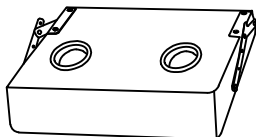
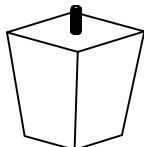

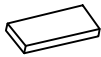

CHAISE ON RIGHT













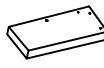

WF284017 - COMPONENT LIST

NO.	DRAWING	QTY	DESCRIPTION
X		1	STORAGE
R		1	SOFA MIDDLE BACK CUSHION
G		4	PLASTIC LEGS

WF284016 - COMPONENT LIST

NO.	DRAWING	QTY	DESCRIPTION
A		1	CHAISE SEAT FRAME
B		1	RSF SHORT CHAISE BACK REST
C		1	CHAISE BACK REST
D		1	RSF LONG CHAISE BACK REST
E1		1	REAR SEAT CUSHION
E2		1	MIDDLE SEAT CUSHION
E3		1	FRONT SEAT CUSHION
F2		1	MIDDLE BACK CUSHION
F3		1	REAR BACK CUSHION
G		4	PLASTIC LEGS

WF284015 - COMPONENT LIST

NO.	DRAWING	QTY	DESCRIPTION
M		1	SOFA SEAT FRAME
N		1	SOFA BACK REST
O		1	ARM
P		3	SOFA SEAT CUSHION
Q		2	SOFA BACK CUSHION
F1		1	CHAISE BACK CUSHION
G		4	PLASTIC LEGS
H		11	PLAT WASHER Ø5/16' X 22MM
I		11	NUT Ø5/16" X 12MM
J		11	BOLT Ø5/16" X 90MM
S		4	BOLT Ø1/4" x 25MM
T		1	ALLEN KEY
K		1	OPEN WRENCH

Please follow the drawings below to assemble the item.
 Legs and hardware are stored in small carton box as shown in drawings, please take out for assembly.

PARTS LIST OF WF284016 BOX

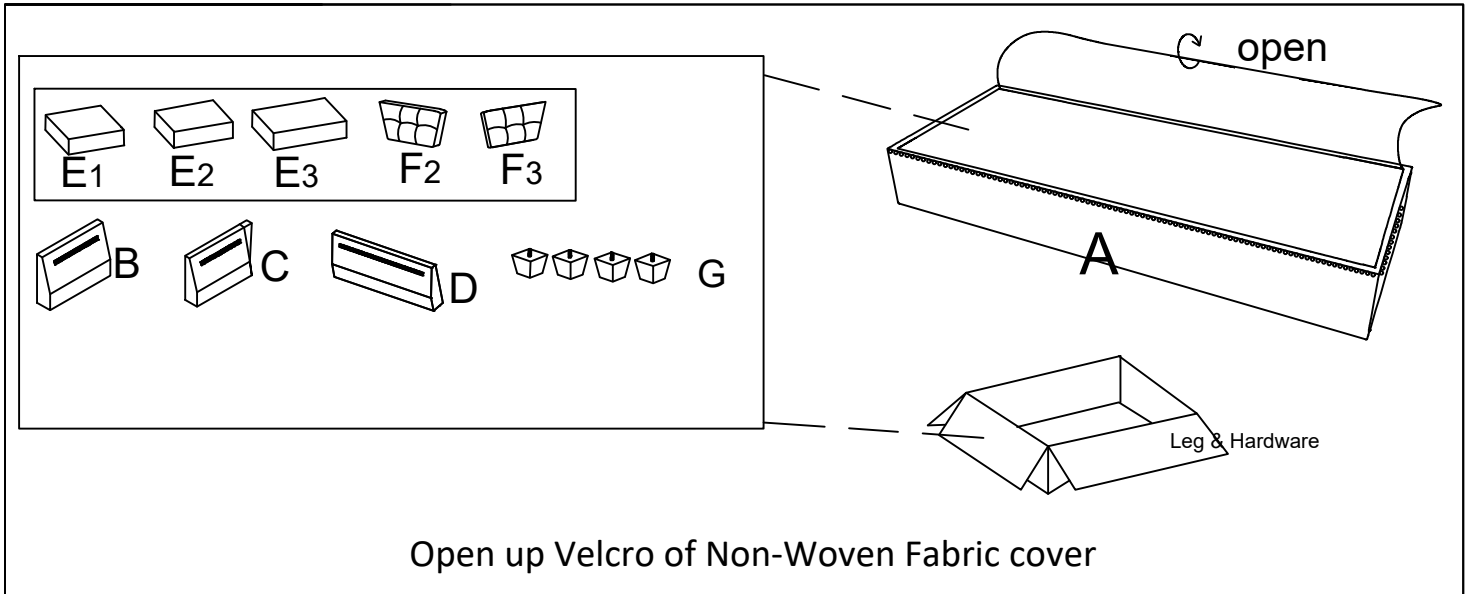

PARTS LIST OF WF284015 BOX

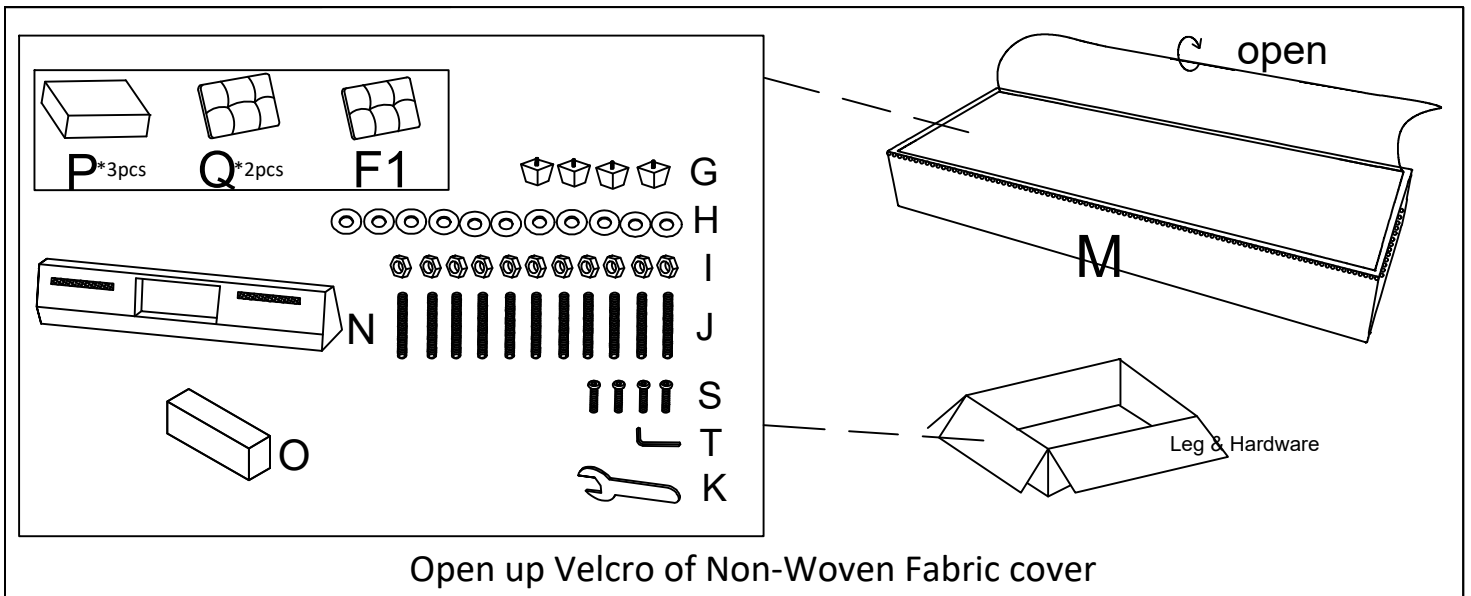

PARTS LIST OF WF284017 BOX

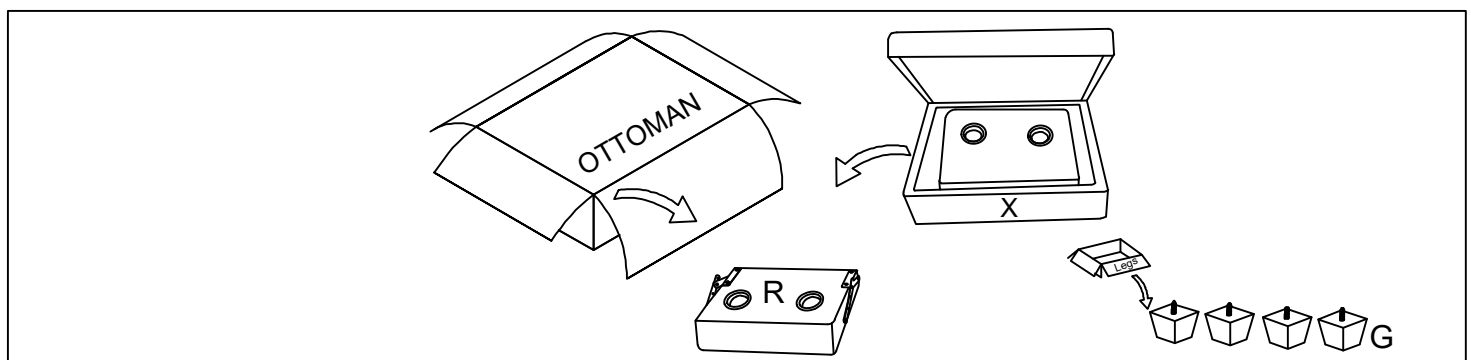

Please follow the drawings below to assemble the item.

Legs and hardware are stored in small carton box as shown in drawings, please take out for assembly.

Step 1

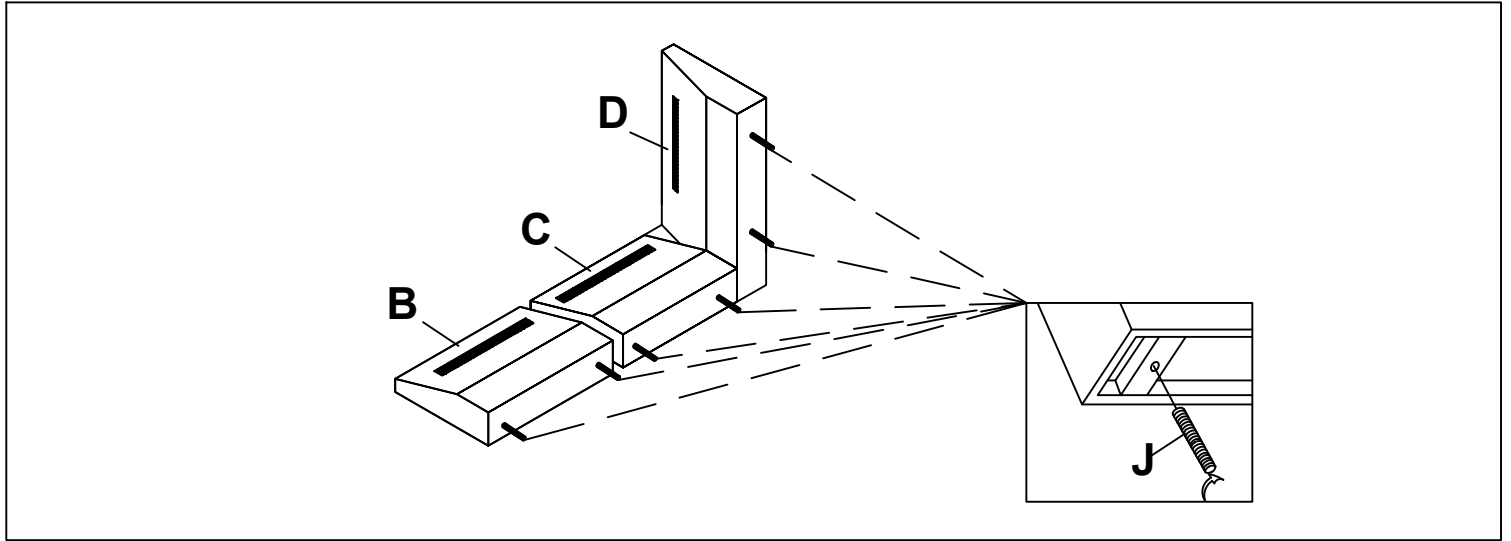

Step 2

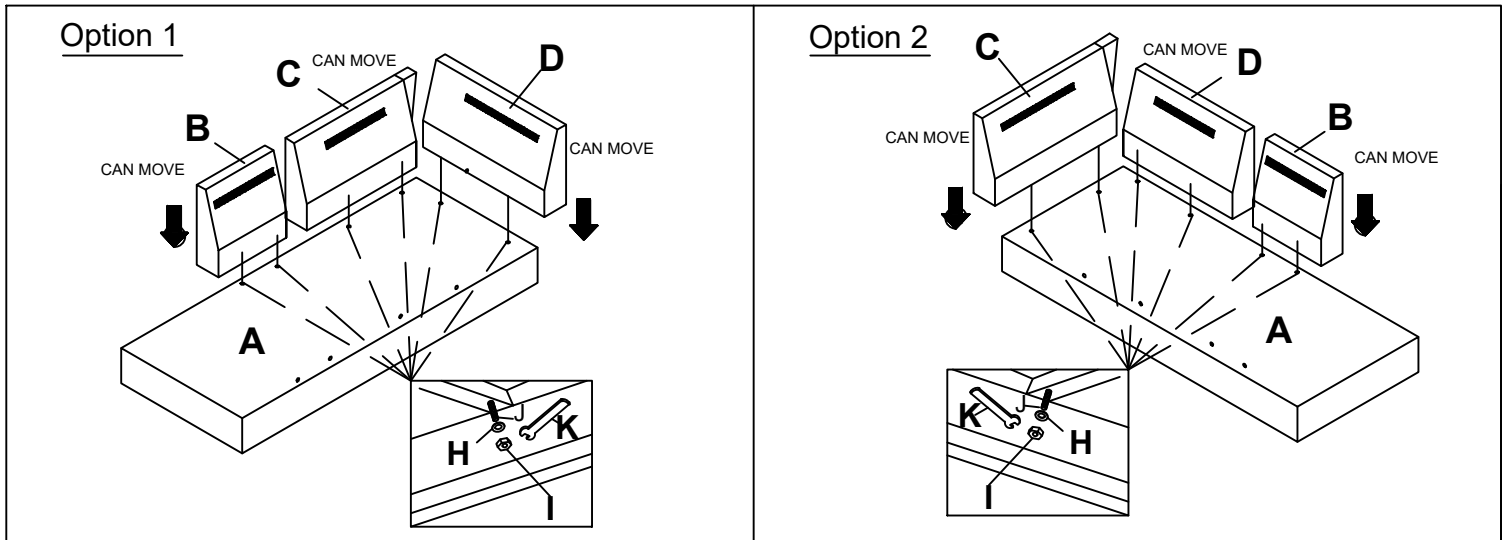

Step 3

Chaise frame finished!

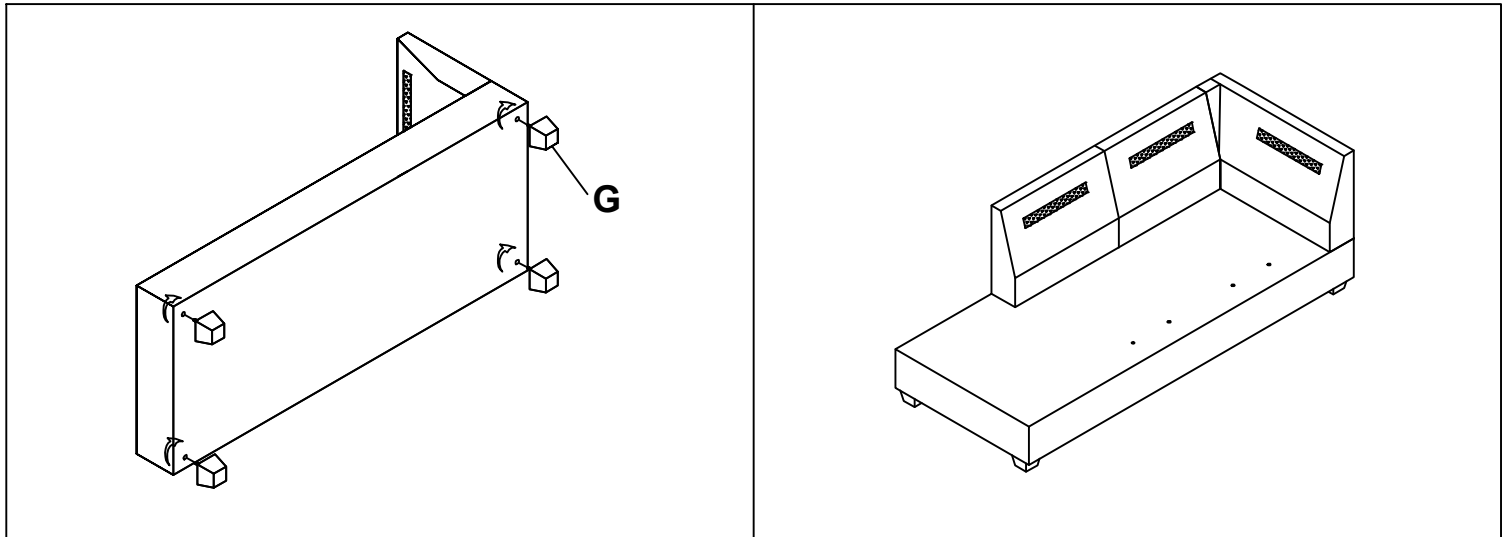

Please follow the drawings below to assemble the item.
Legs and hardware are stored in small carton box as shown in drawings, please take out for assembly.

Step 4

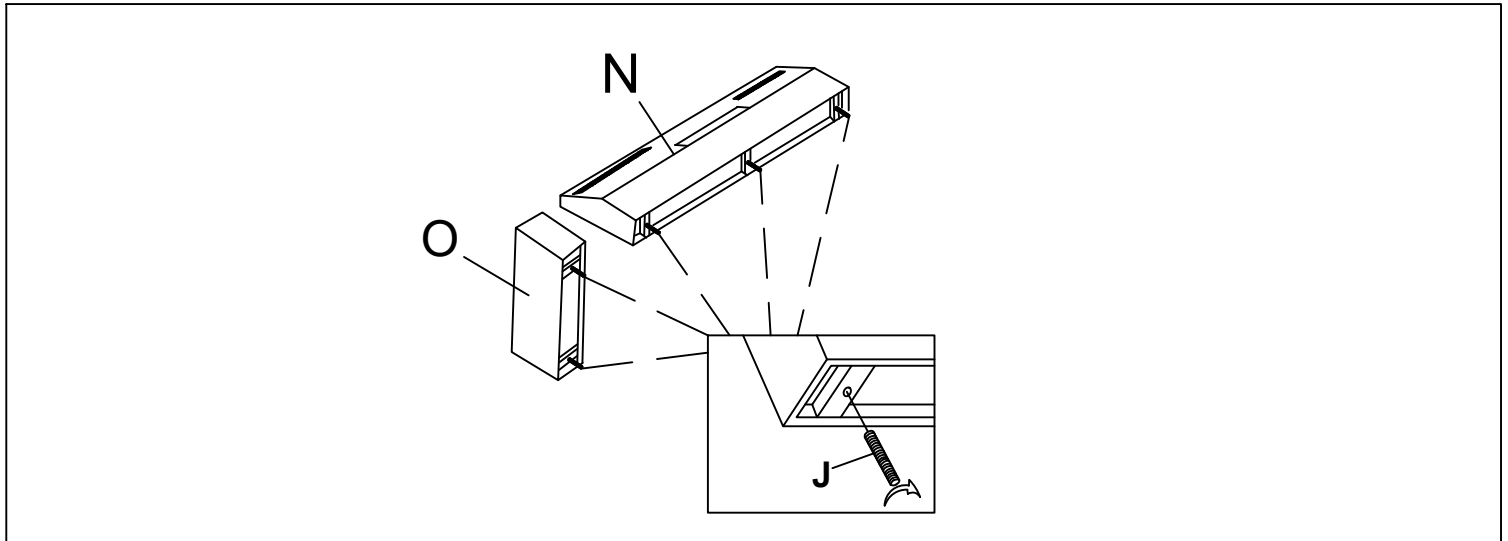

Step 5

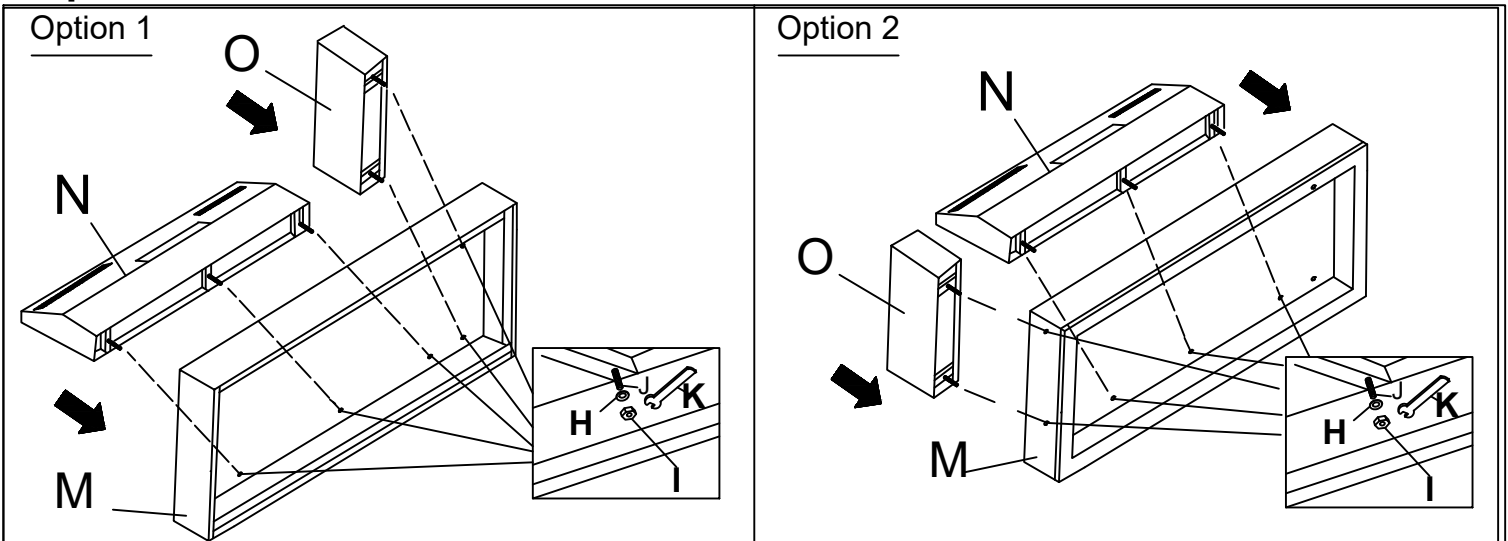

PAGE 4 OF 6

Step 6

Sofa frame finished!

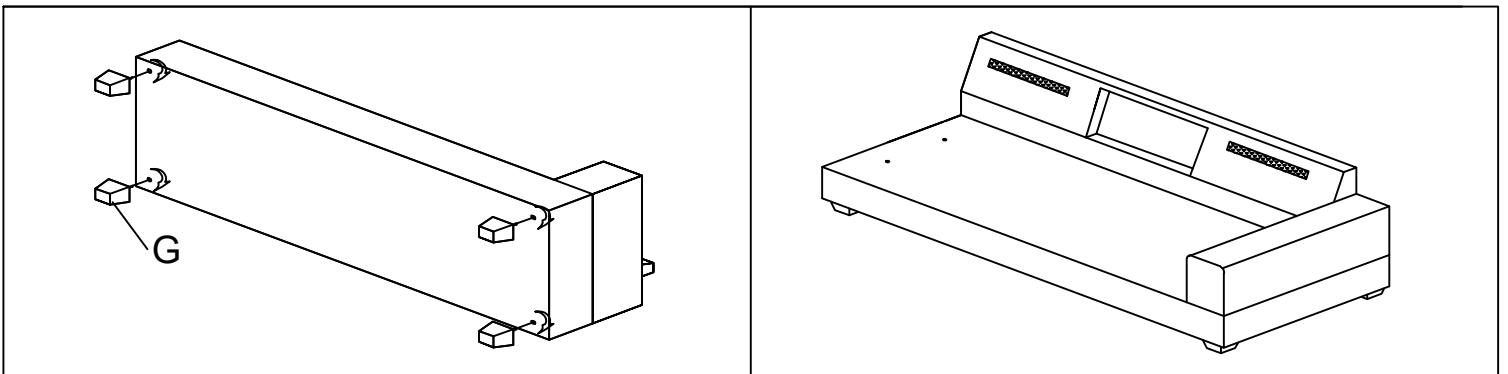

Step 7

Option 1

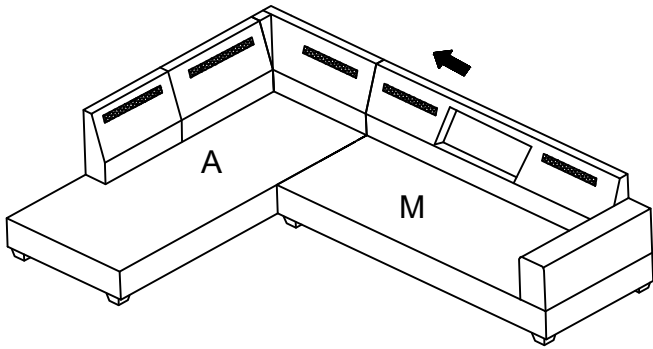

Option 2

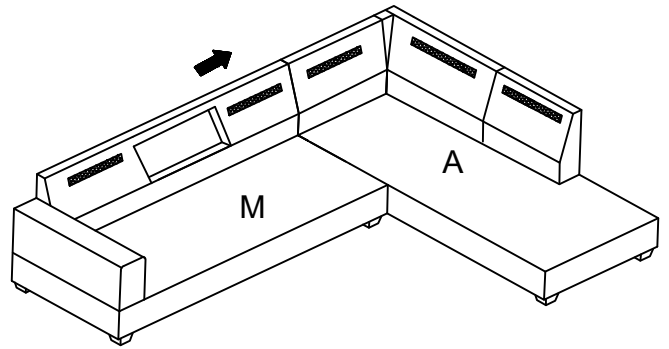

Step 8

Option 1

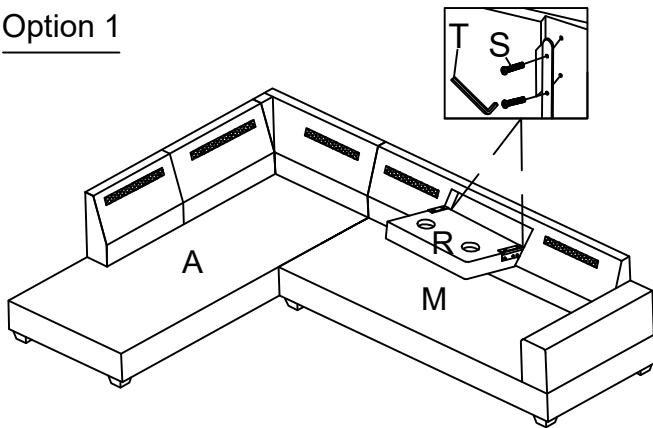

Option 2

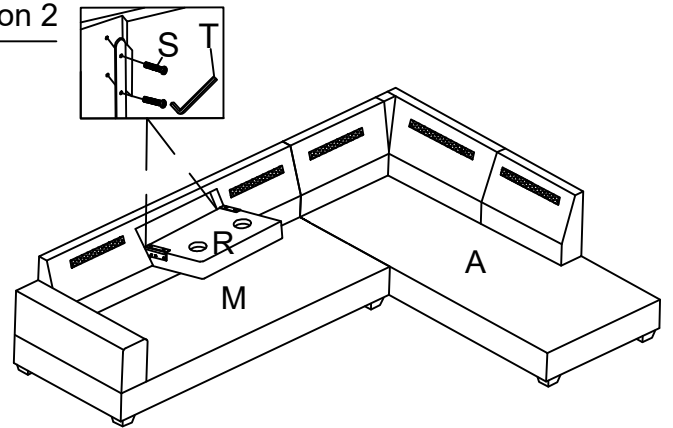

Step 9

Option 1

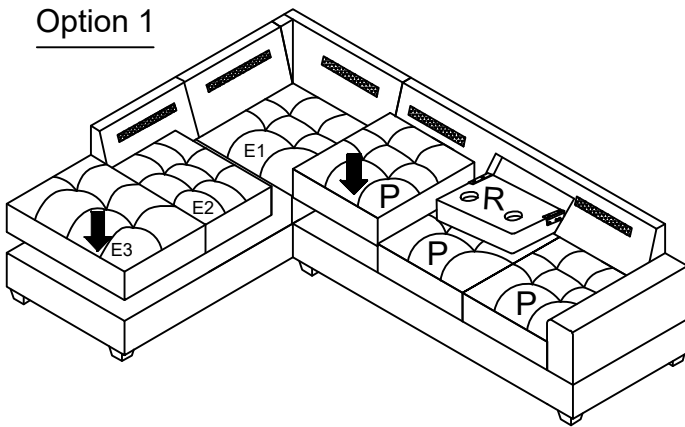

Option 2

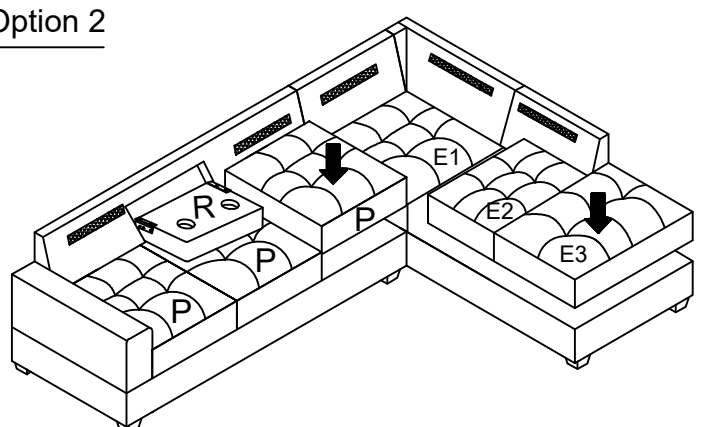

Step 10

Option 1

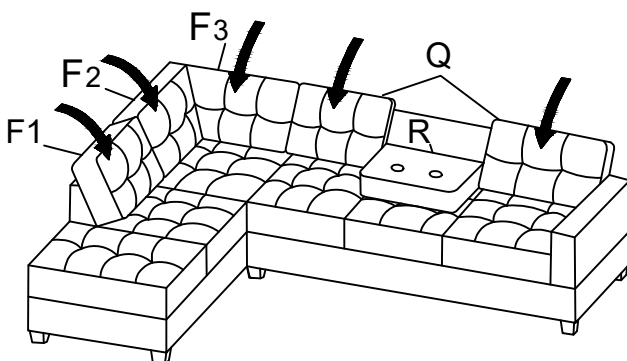

Option 2

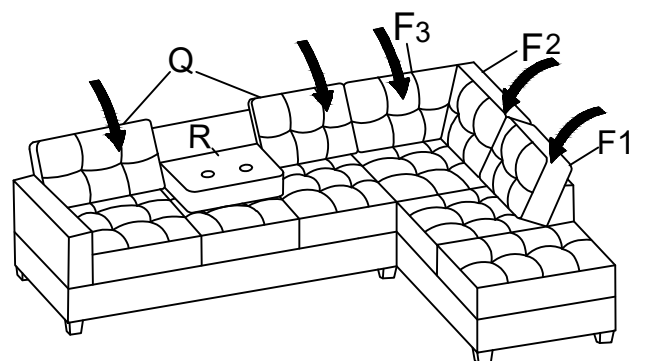

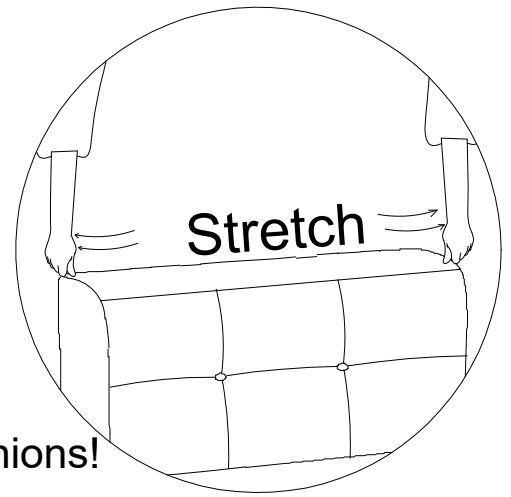
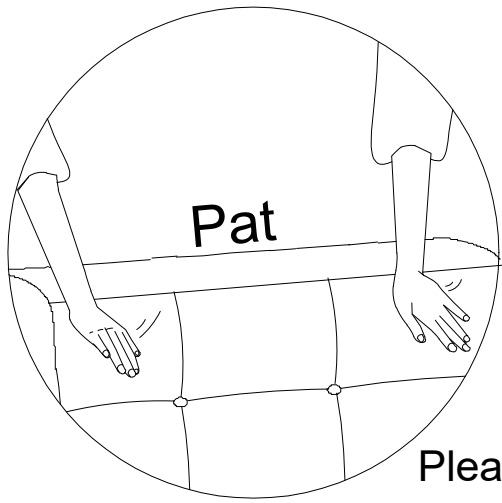

Please apply for all cushions!

Step 11

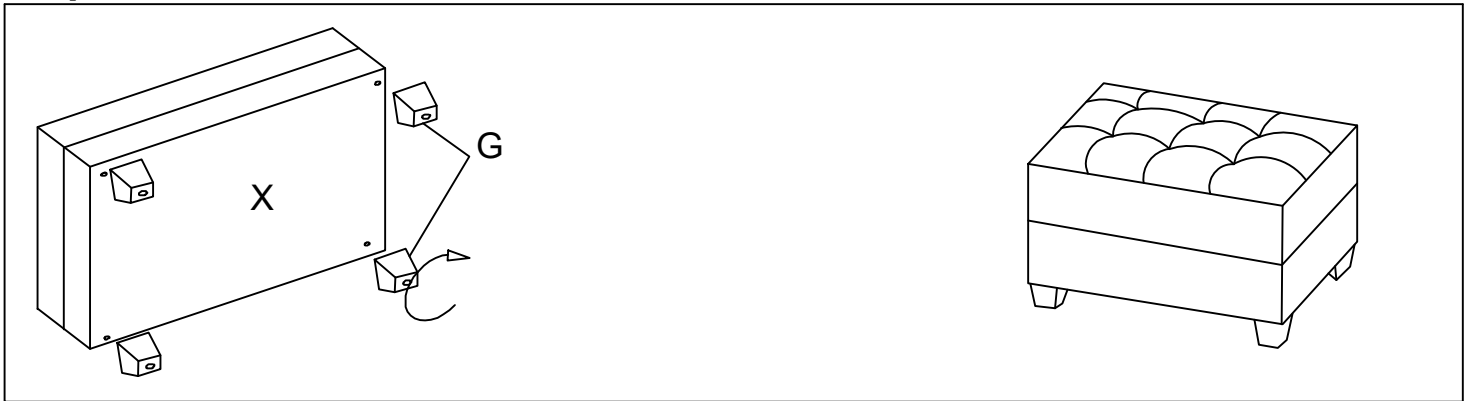

Assembly Completed!

THE CONSOLE PIECE CAN BE DROPPED DOWN AND TURN INTO AN ARMREST PANEL WITH CUP HOLDERS

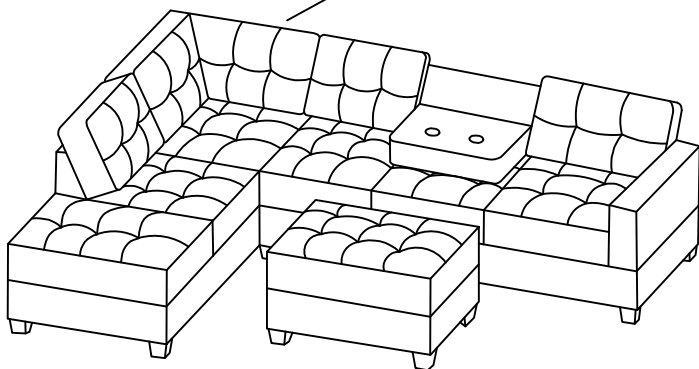

CHAISE ON LEFT

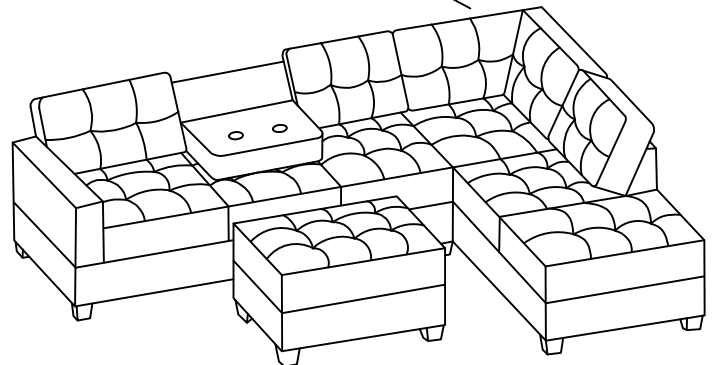

CHAISE ON RIGHT