

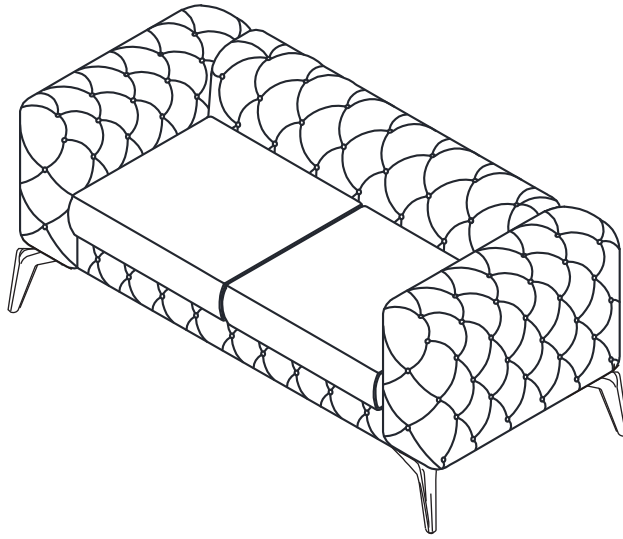

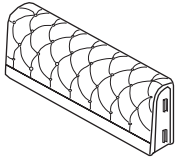



ASSEMBLY INSTRUCTIONS

2 SEATER SOFA

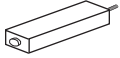
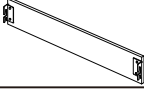

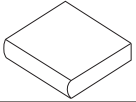

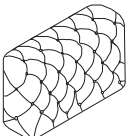
2 SEATER SOFA is packed in 3 cases

Carton	Disignation	Part	Hardware
1/3	Backrest	#2 	(A) (B) (C) (D)
	Leg	#6 	
	Support leg	#8 	
	Former board	#1 	
2/3	Riser plate	#5 	
	Cushion	#7 	
3/3	Left arm	#3 	
	Right arm	#4 	

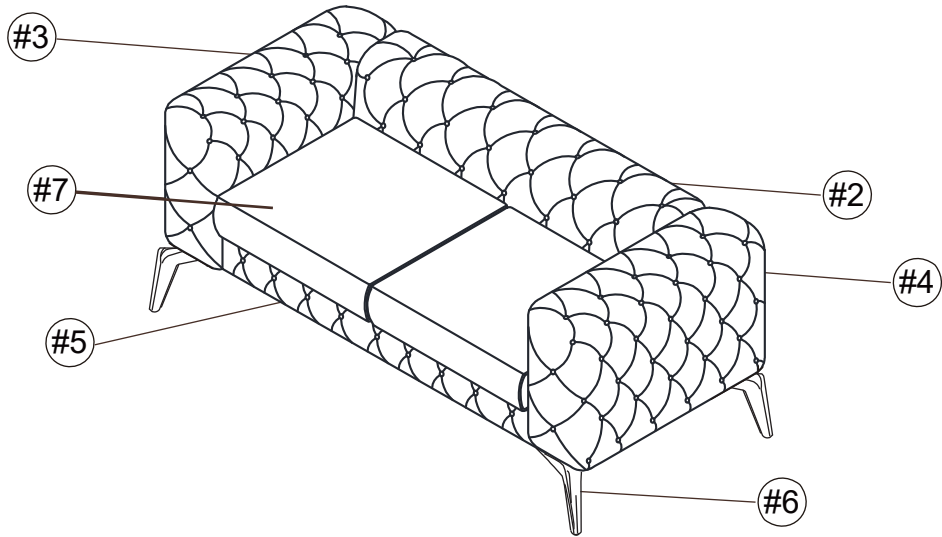

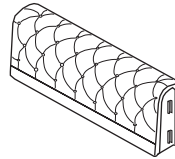
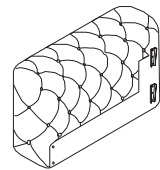
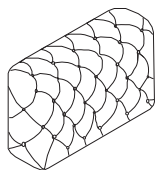
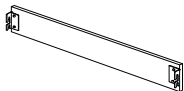
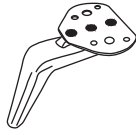
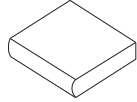

ASSEMBLY INSTRUCTIONS



PARTS

<p>#1 1pc</p>  <p>RISER PLATE</p>	<p>#2 1pc</p>  <p>BACKREST</p>	<p>#3 1pc</p>  <p>LEFT ARM</p>	<p>#4 1pc</p>  <p>RIGHT ARM</p>
<p>#5 1pc</p>  <p>FORMER BOARD</p>	<p>#6 4pcs</p>  <p>LEG</p>	<p>#7 2pcs</p>  <p>CUSHION</p>	<p>#8 3pcs</p>  <p>SUPPORT LEG</p>

HARDWARE

<p>#A 12 pcs</p>  <p>BOLT 1 -1/2" L</p>	<p>#B 1 pc</p>  <p>ALLEN KEY 4mm L</p>	<p>#C 12 pcs</p>  <p>FLAT WASHER 16mm</p>	<p>#D 12 pcs</p>  <p>SPRING WASHER</p>
--	---	---	---

ASSEMBLY INSTRUCTIONS

STEP1:

Pull the HOOK&LOOP in the bottom of backrest(#2) and open it,take out paper box (#6,#8,HARDWARE)

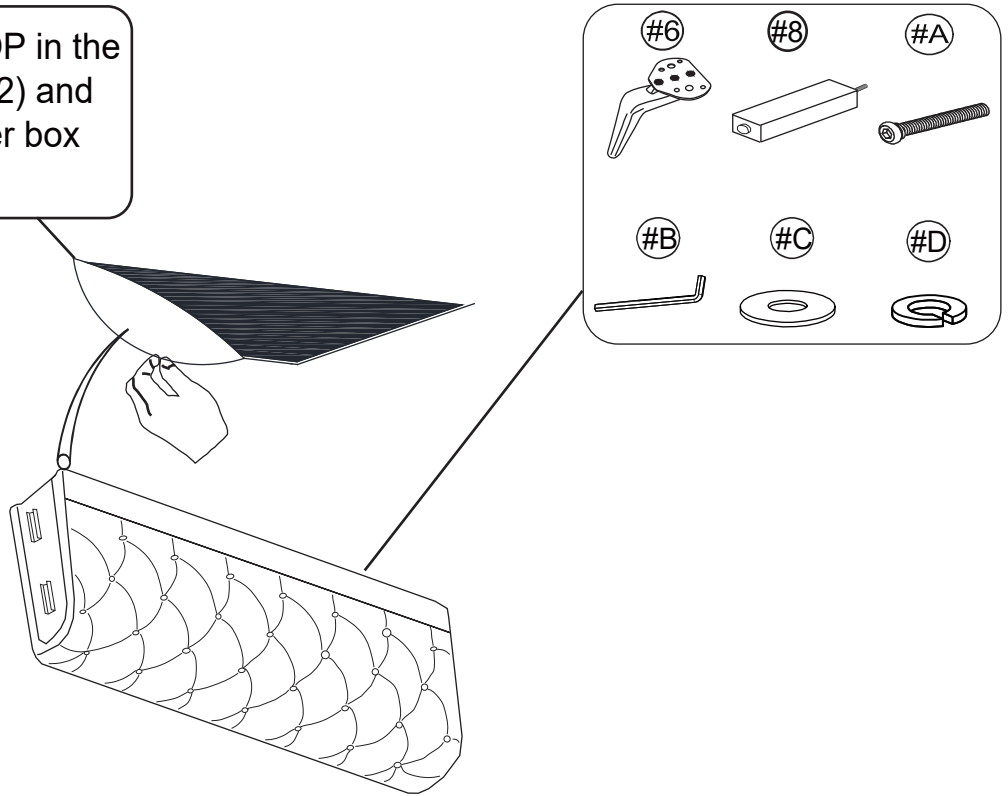

STEP2:

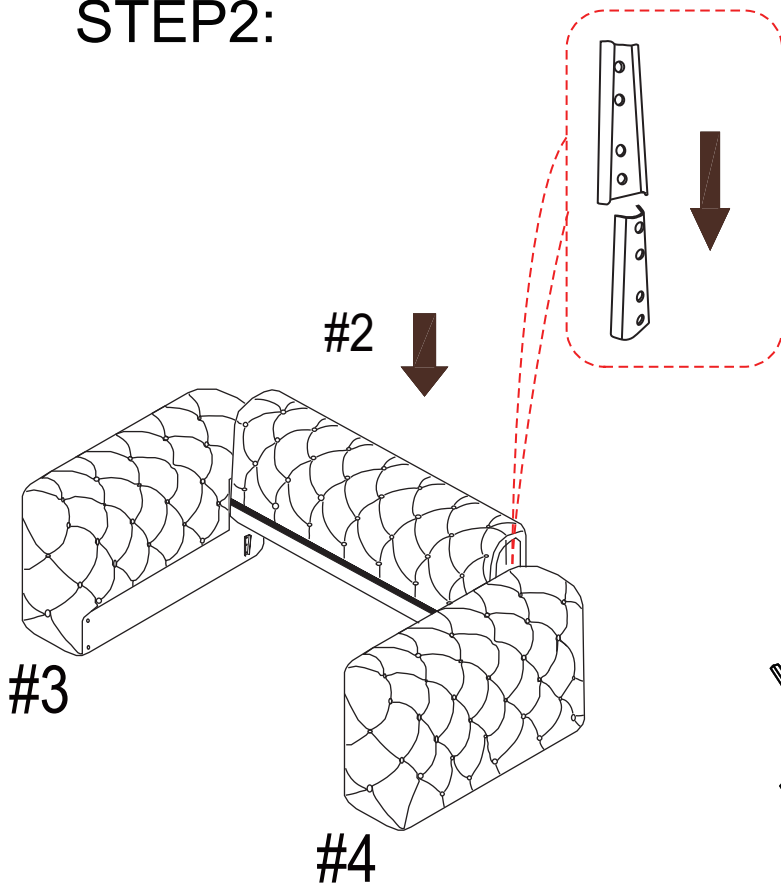

STEP3:

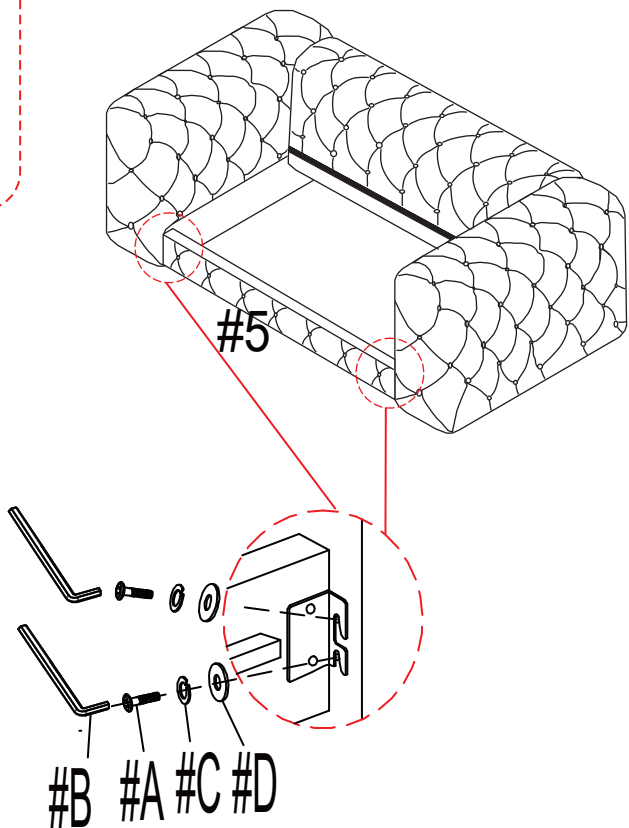

ASSEMBLY INSTRUCTIONS

STEP4:

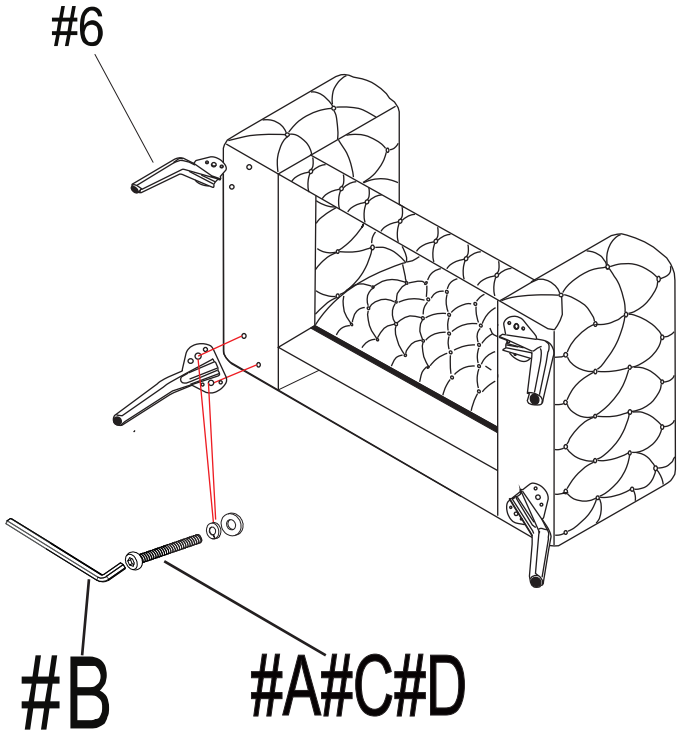

STEP5:

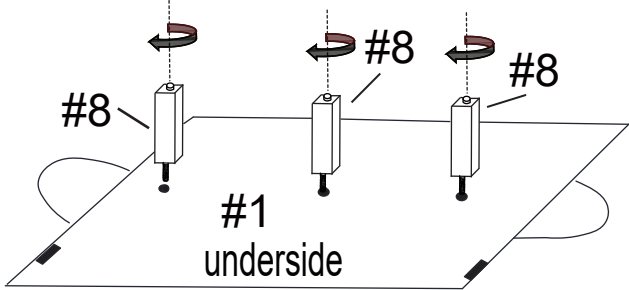

STEP6:

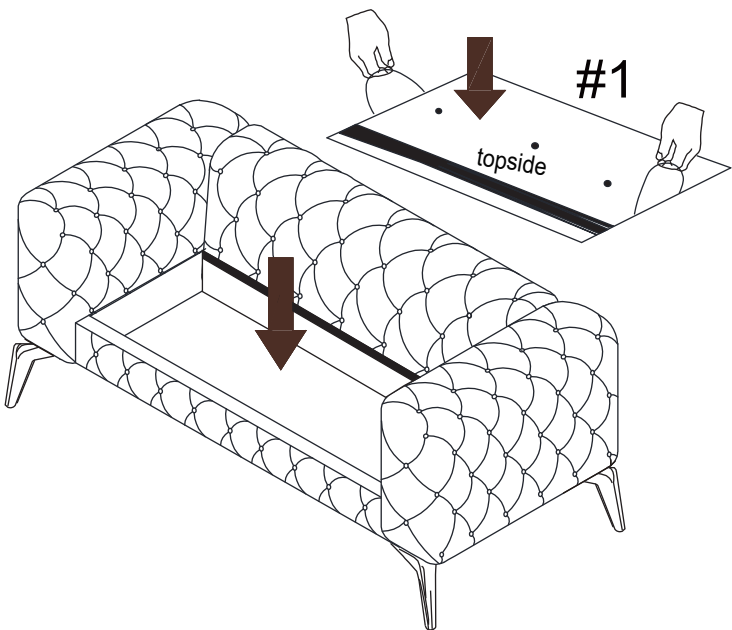

STEP7:

