





ASSEMBLY INSTRUCTION







ITEM NO.: WF288479 SOFA BED
WF288480 SOFA BED

Thank you for purchasing this quality product. Be sure to check all packing material carefully for small parts, which may have come loose inside the carton during shipment. Identify and count all parts and compare with the **HARDWARE LIST** below.

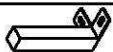
Caution: Please read instructions thoroughly before unpacking assembly parts. Sharp, exposed staple tips can cause injury, therefore, for your production, please remove any exposed staples used in packing.

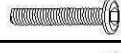
1. We recommend that you assemble this product with the assistance of another person; this will make assembly easier, and will help to eliminate damage to the product or injury to persons during assembly.
2. Please do not over tighten screws or bolt until the assembly is completed.
3. Please put all parts on a non-abrasive floor before assembly, and follow the assembly steps to assemble your sofa.

PARTS LIST			
No	Description	Sketch	Q'ty
1	Left Sofa Body		1 PC
2	Right Sofa Body		1 PC
3	Left Facing Arm		1 PC
4	Right Facing Arm		1 PC
5	Pillow		2 PCS

HARDWARE LIST			
No	Description	Sketch	Q'ty
A	Leg		4 PCS
B	Center Leg		2 PCS
C	Hex Key M4 x 21 x 57 mm		1 PC
D	Bolt 5/16" x 40mm		2 PCS
E	Bolt 5/16" x 20mm		12 PCS
F	Spring Washer 5/16"		14 PCS
I	Washer M5/16" x 16 x 2mm		14 PCS

Step 1 :

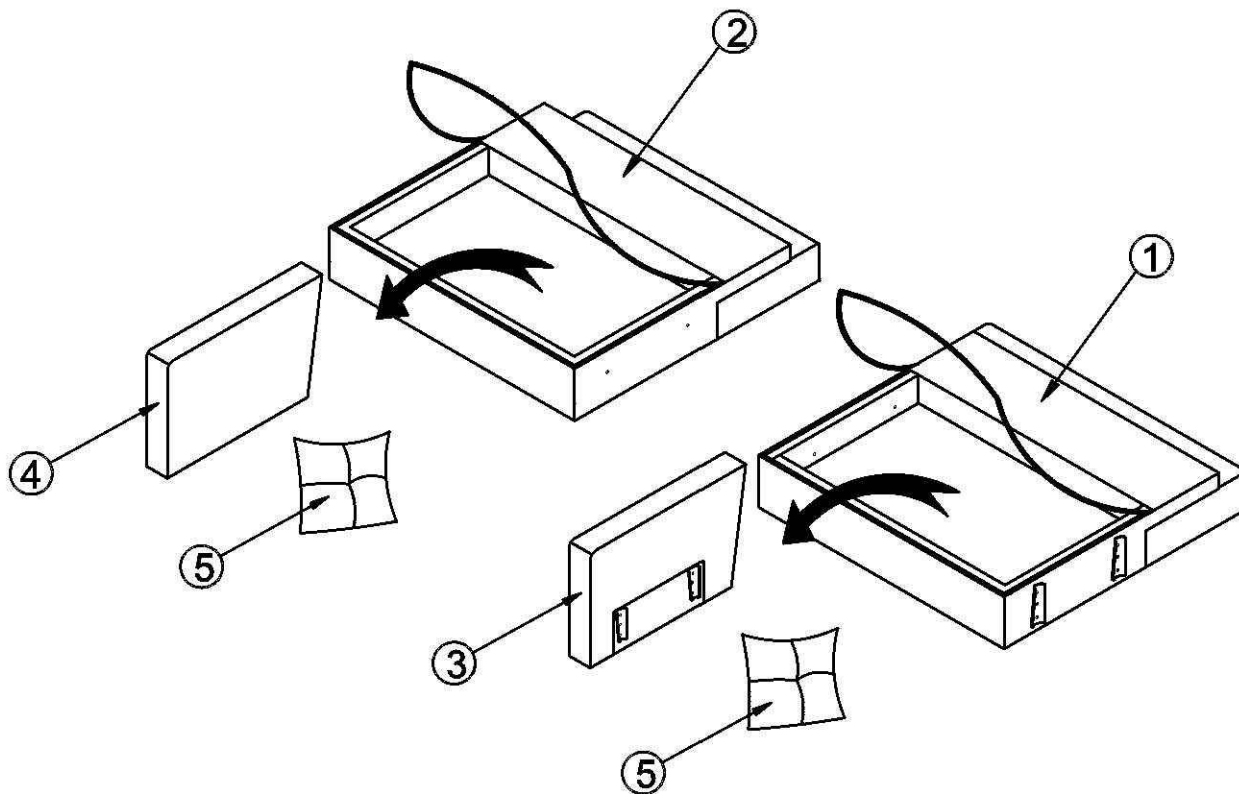

ASSEMBLY INSTRUCTION

ITEM NO.: WF288479 SOFA BED

WF288480 SOFA BED

Step 2 :

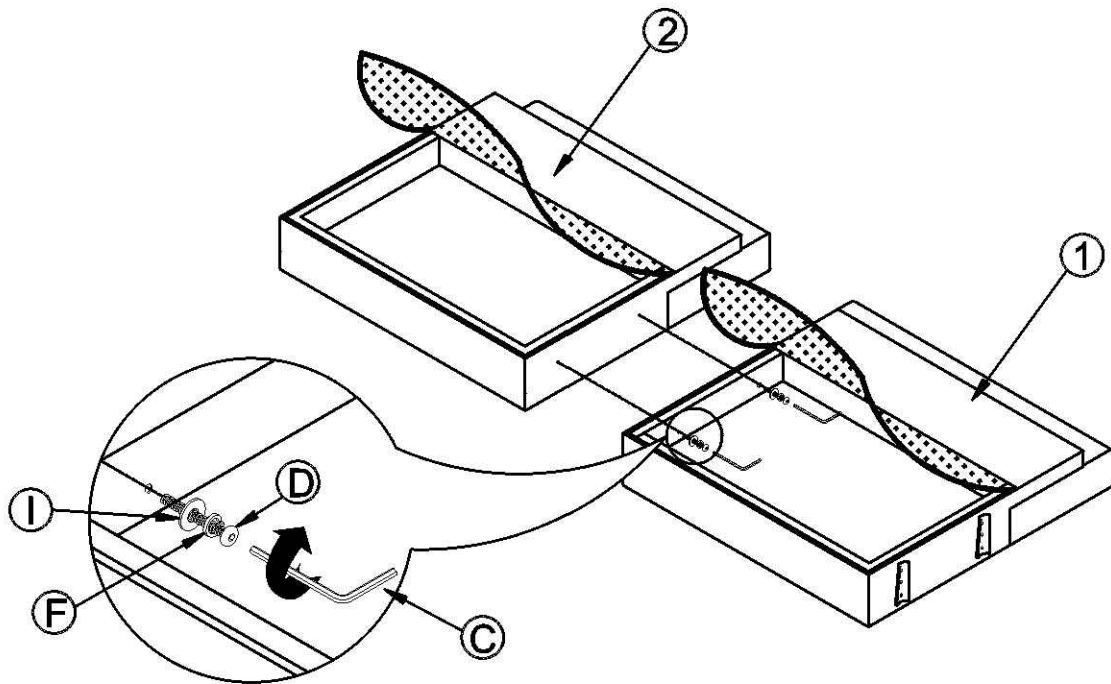

Step 3 :

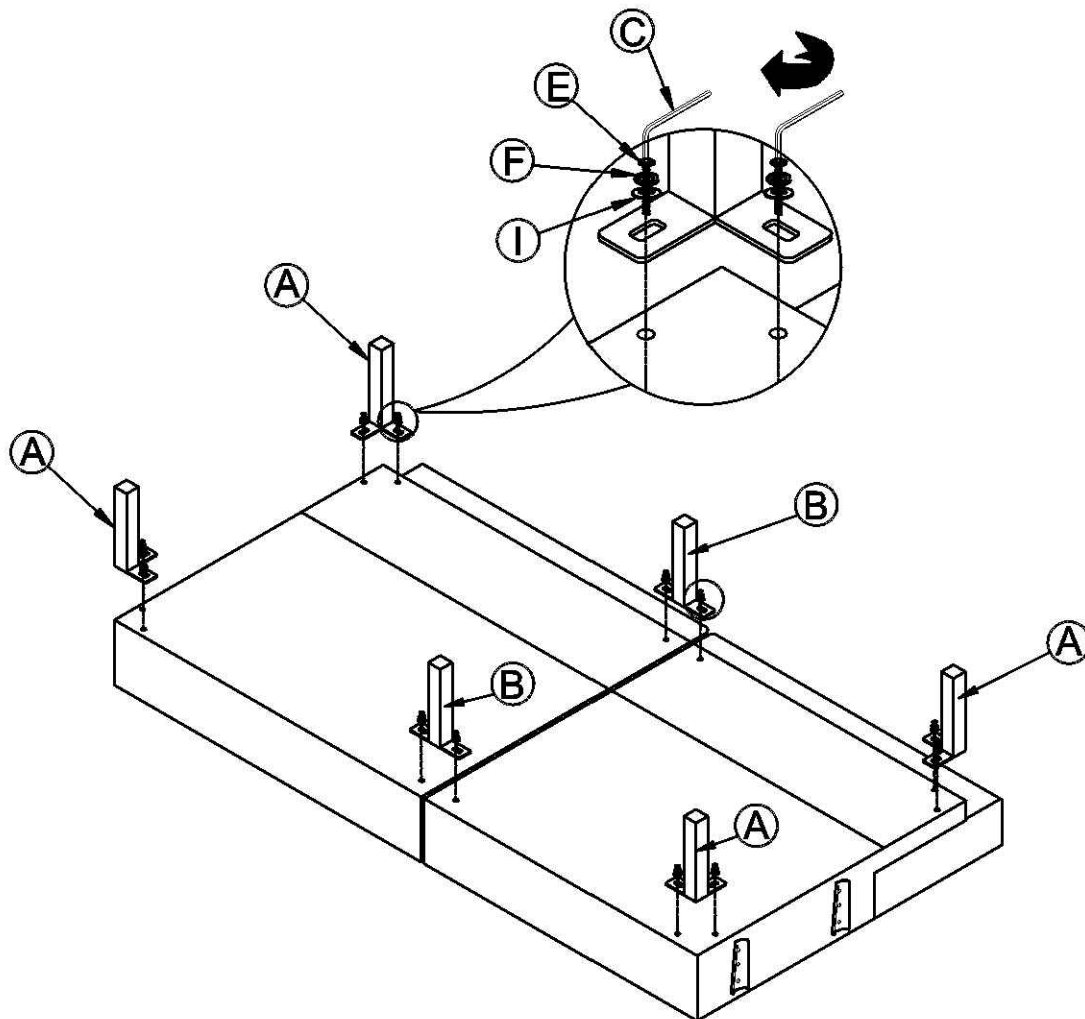

ASSEMBLY INSTRUCTION

ITEM NO.: WF288479 SOFA BED

WF288480 SOFA BED

Step 4 :

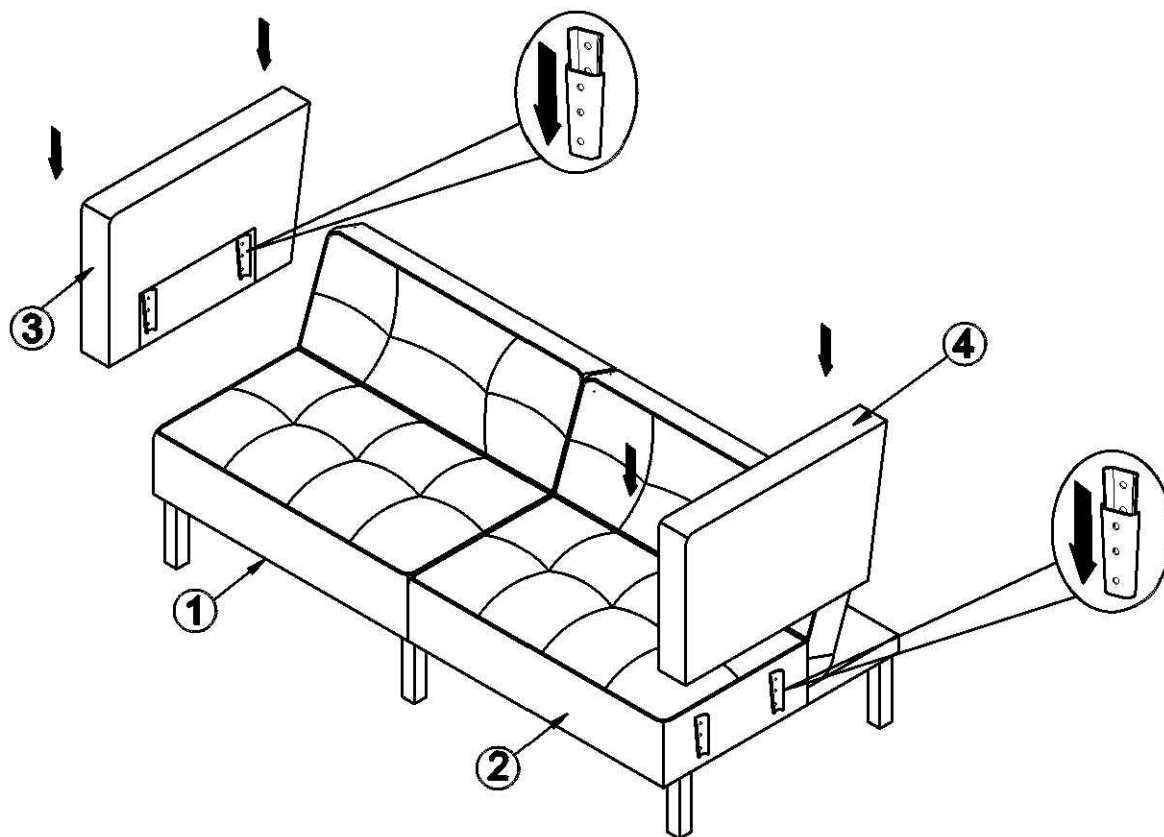

Step 5 :

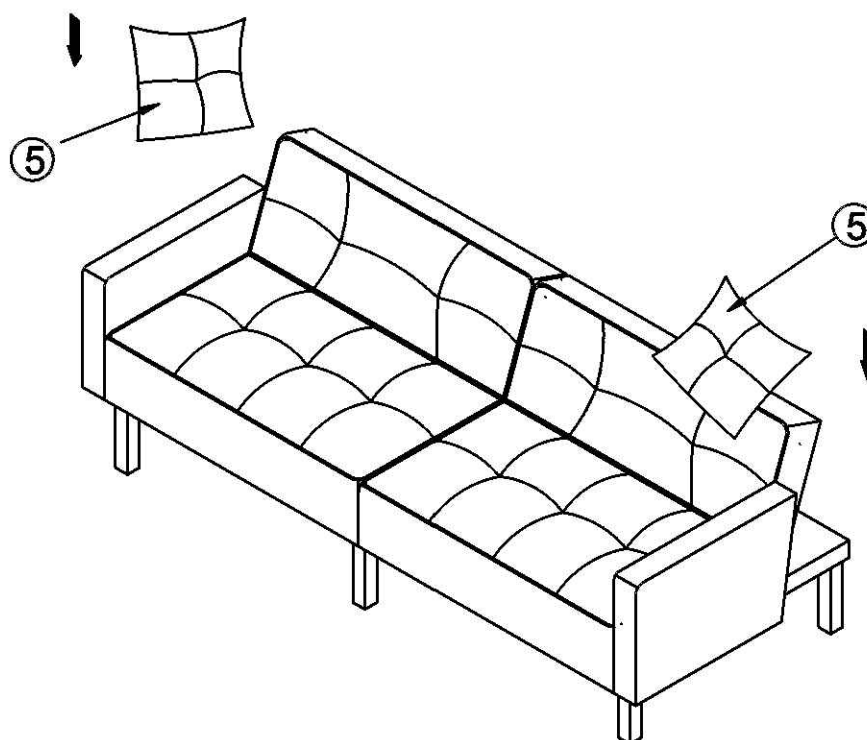

ASSEMBLY INSTRUCTION

ITEM NO.: WF288479 SOFA BED

WF288480 SOFA BED

