

# TRAMPOLINE WITH ENCLOSURE NET

## U S E R M A N U A L

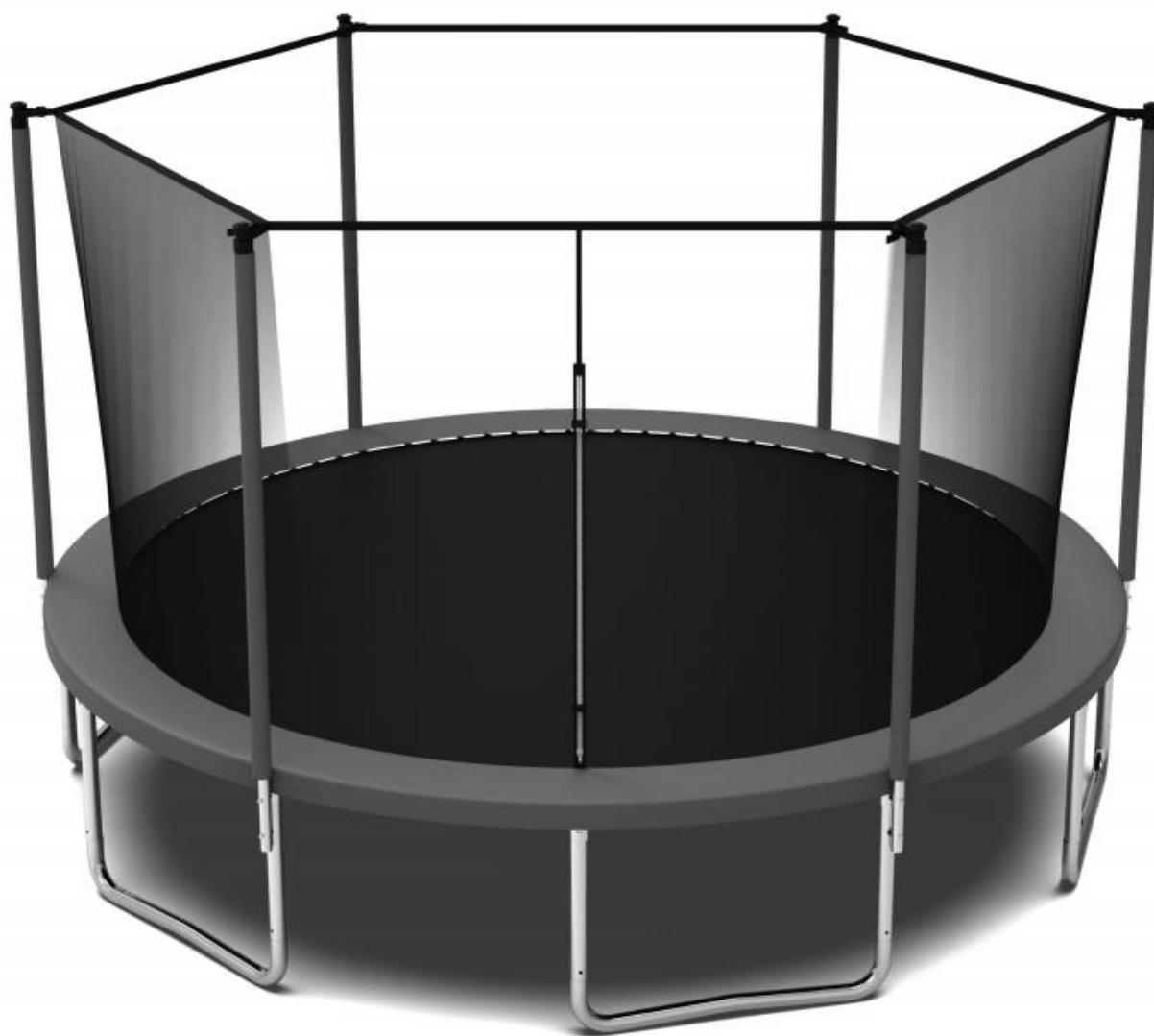

### MSG-TN-1406



If you can't contact the seller in case of any problems, please contact the trampoline factory through this email address and we will provide you with assistance.  
[service@cnmersco.com](mailto:service@cnmersco.com)

# INSTALLATION WARNING

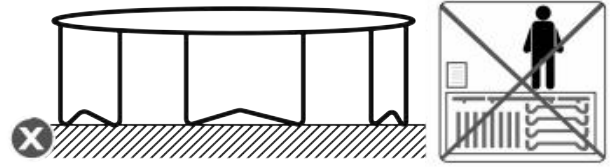
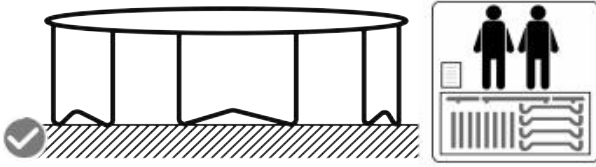

1. Please make sure at least 2 people install the trampoline.

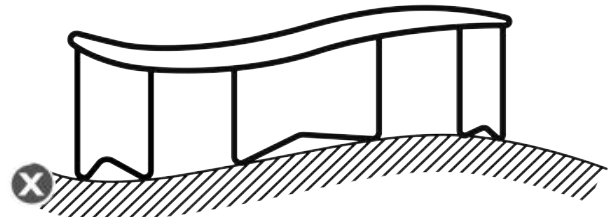
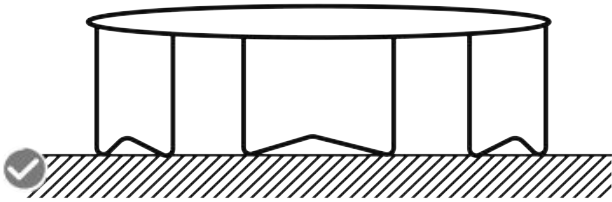

2. Please install the trampoline on the flat and non-slippery ground.

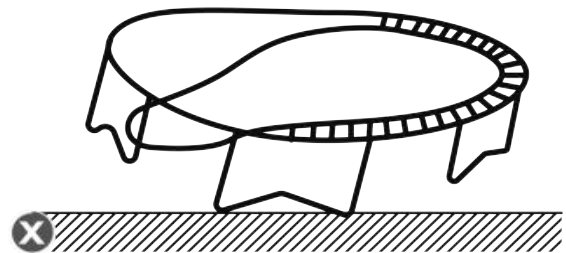
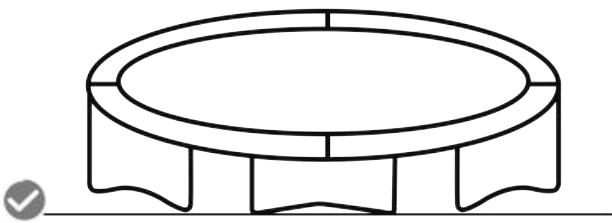

3. Please install the springs in the X-shape order one by one as requested in the instructions.

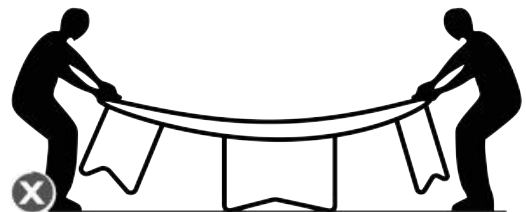
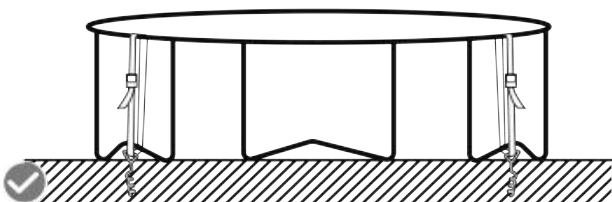

4. Please do not move or lift the trampoline during or after installation but use the tie down stakes kit to secure it.

# USE WARNING



Do not somersault or flip.



Do not dunk and hold onto the ring.



Do not jump onto the trampoline from a height.



Do not intentionally hit the safety enclosure net.



Do not use the trampoline in stormy weather but disassemble and store it.



Do not exceed 330lbs for a single user and do not exceed the total weight for multiple users.



Do not place any sharp objects on the trampoline.



Do not use during pregnancy, high blood pressure or other injuries.

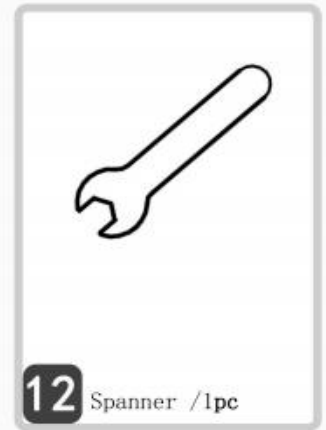
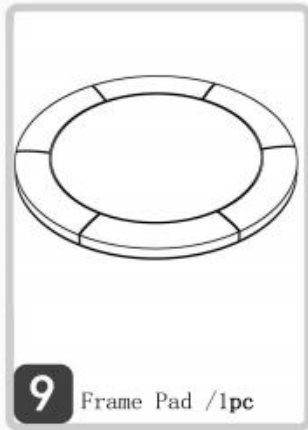
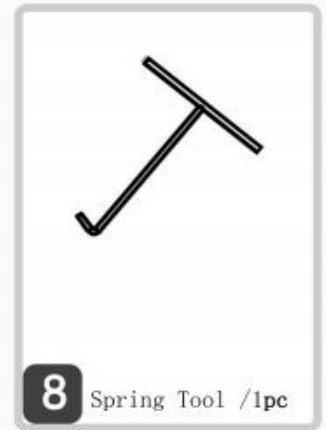
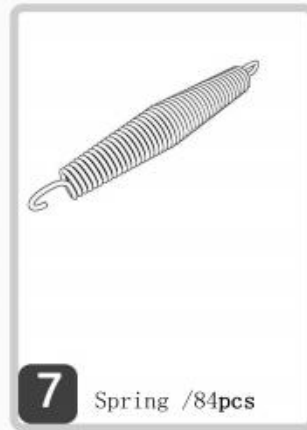
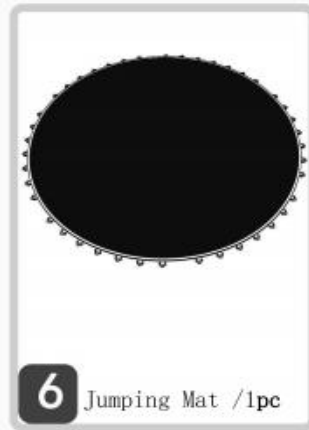
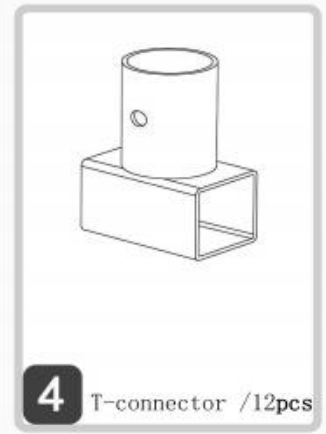
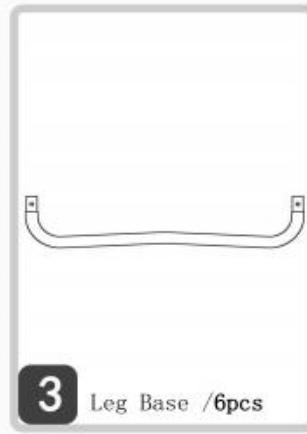
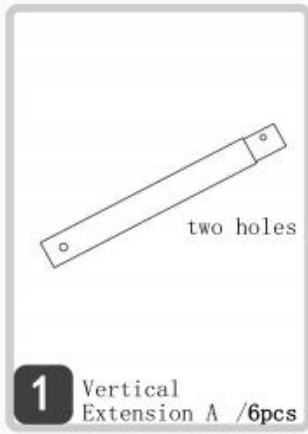

# INSTRUCTION

## STEP 1:

Insert all Vertical Leg Extensions(#1) and Leg Extensions(#2)into the Leg (#3), assemble leg extension (#1) on the left, leg extension(#2) on the right.

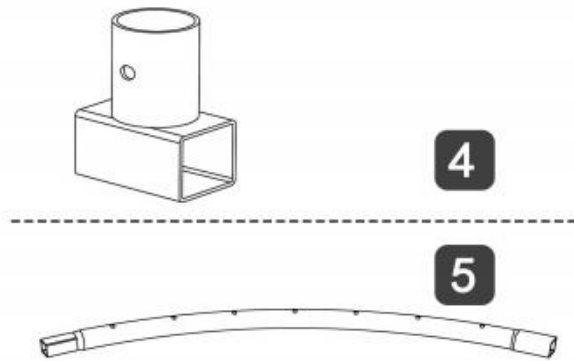

## STEP 2:

2 People would be necessary at this part. Find out all the Top Rail(#5), and simply slide the thicker end to the T-Connector(#4), then connect the other side of T-Connector(#4) to adjacent section with the thinner side.

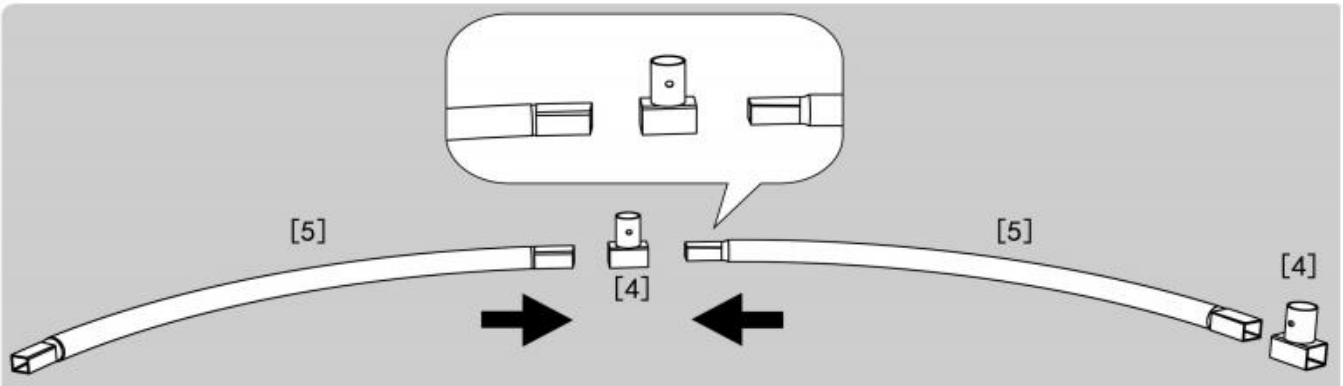

**STEP 3:**

Make sure you find the most flat place and it's plenty enough to put a trampoline, 2 people would be necessary at this part, one person lifts up the support assembly in step 1, and the other person connects the downward connectors in the top rails with leg sockets in step 2 to the support base.

keep repeating step 3 until the 6 bases are connected, as shown in the picture.

Don't forget to check the Connector is tight enough.

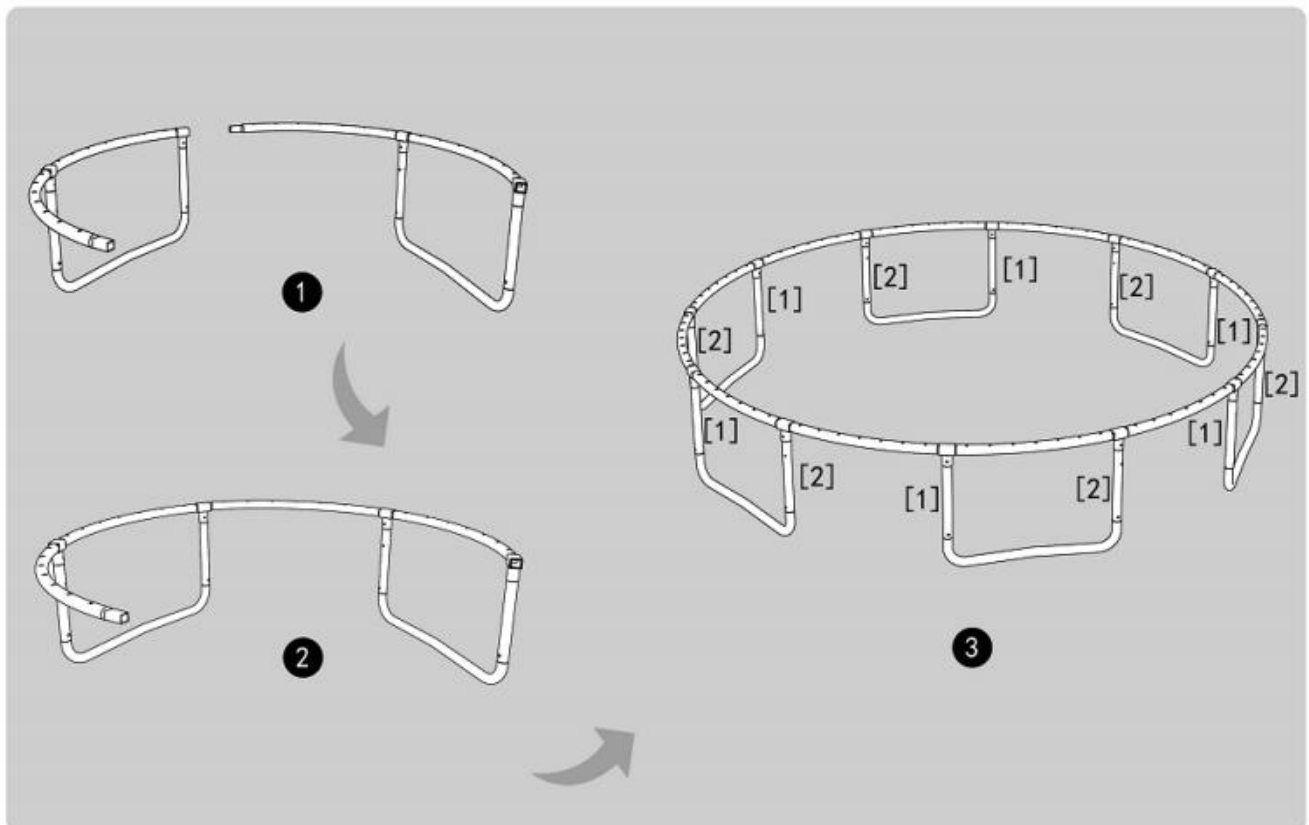
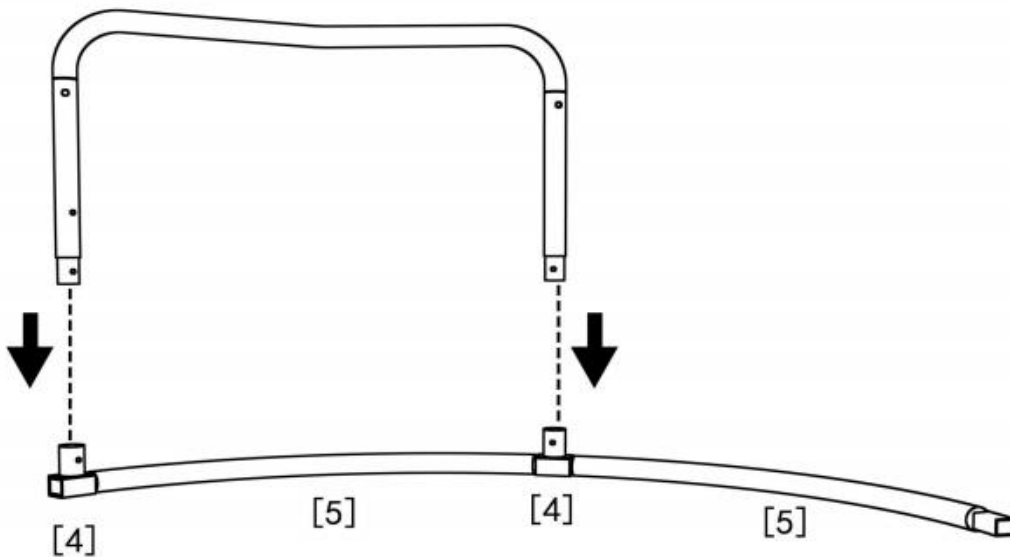

#### STEP4-Trampoline Mat Assembly

The springs need to be placed in position as shown in the diagram below, in order to pull the "Trampoline Mat" in all four directions. Make sure each V-ring on the mat corresponds to every single opening on the top rail.

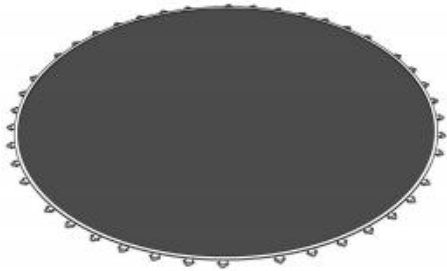

6



7



8

#### MOST IMPORANT TIP:

Count the holes on top rail and the V-rings in mat and mark every quarter point on both mat and top rail, then use the spring to attach the V-rings and hole which were marked.

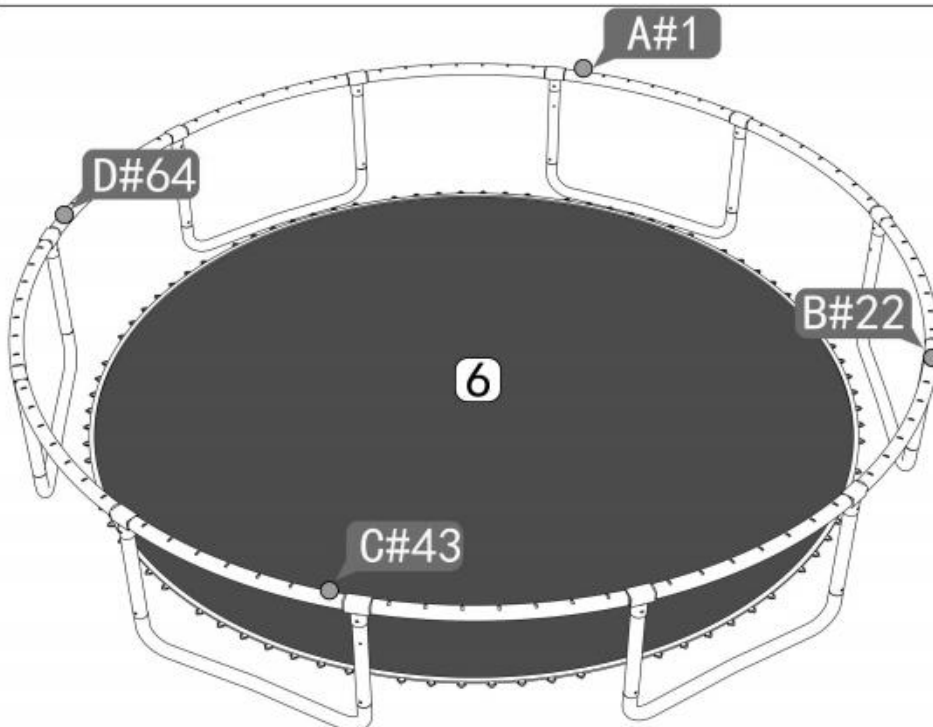

Lay out the Jumping Mat (#6) inside the frame on the floor as the picture on the left.

**TIP 1**

When assembling the jumping mat, please make sure to attach the jumping mat with 4 symmetrical point fixed into the frame first. Then install springs symmetrically every 3 holes along the 4 fixed point.

**TIP 2**

You will need at least one person to help this with portion of assembly. You may need to use gloves for this step!

**WARNING**

Please be careful not to hurt your hands or body parts when installing spring the connector points. **DON'T TRY TO PULL THE SPRING WITH NAKED HAND!**

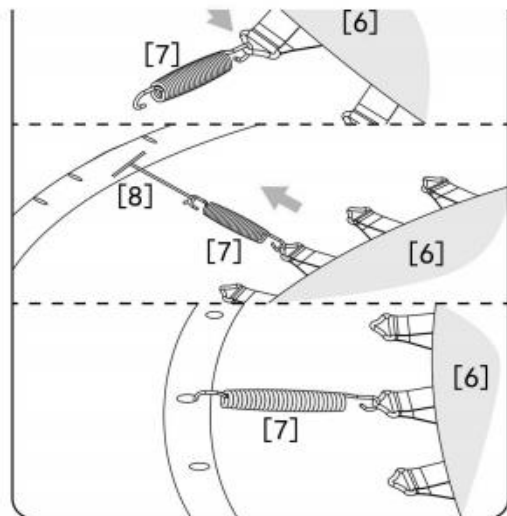
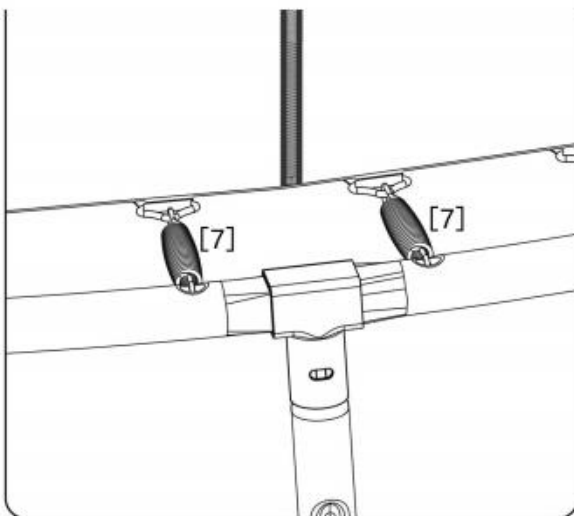
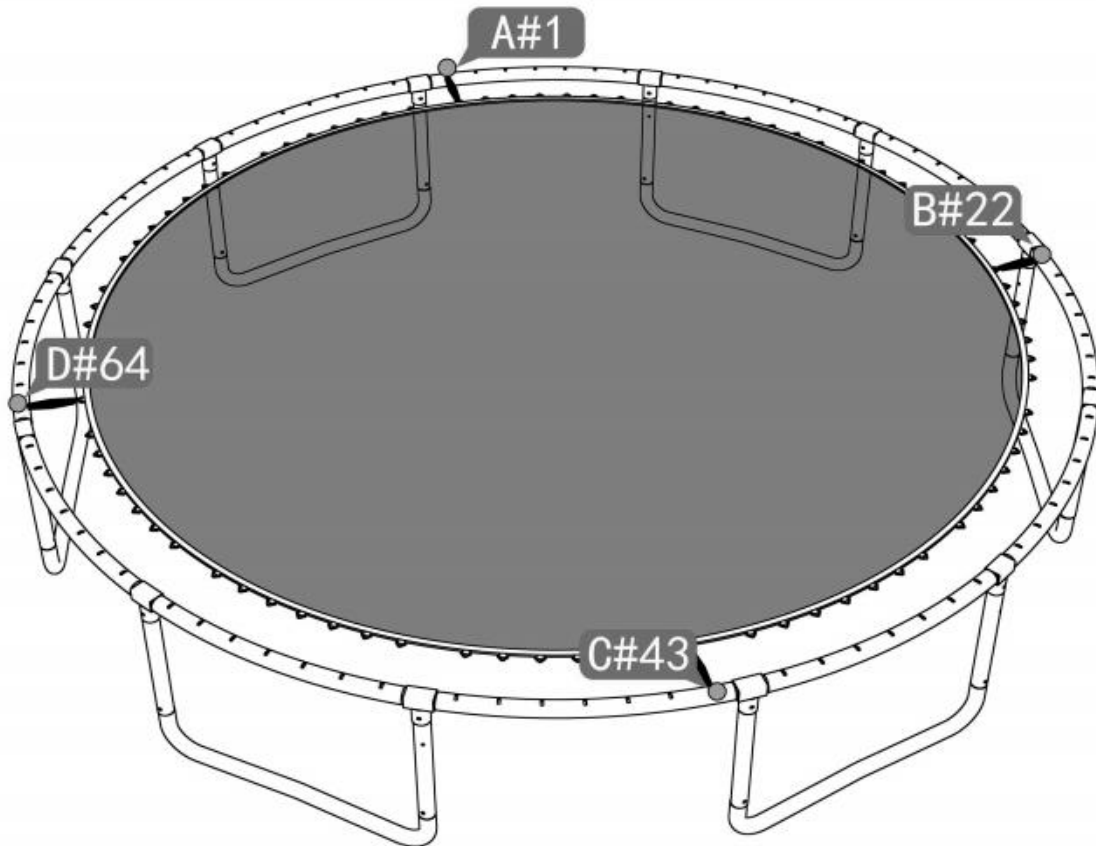



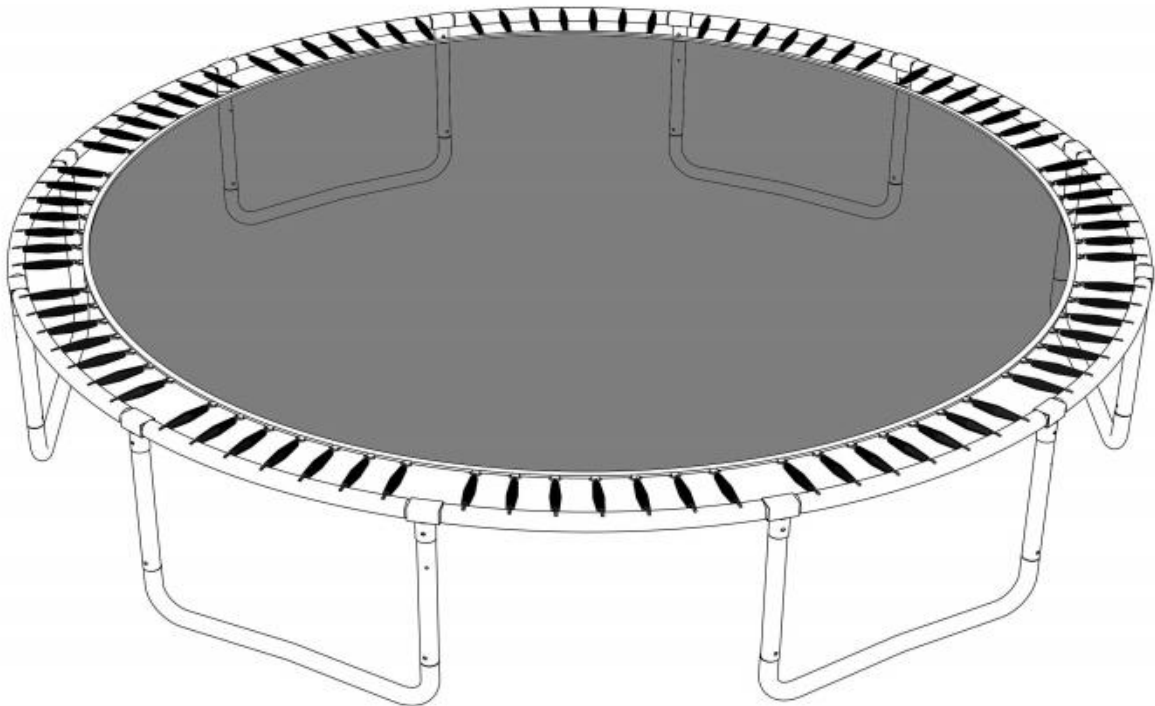
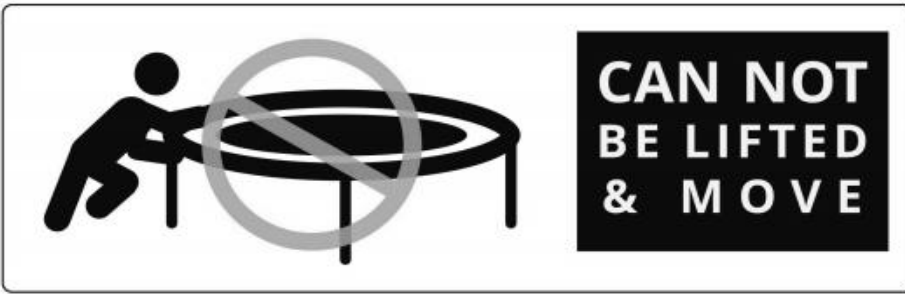

#### HOW TO USE "THE SPRING LOADING TOOL"

Firstly, hang one side of the spring on the triangle attached to the Jumping Mat(#6), and use the spring tool(#8) to hook the other side of spring (As shown in the top image to the right).

Pull the Spring Tool(#8) until the spring hook insert the hole on the Top Rail and disengage the Spring Tool(#8) leaving the Spring(#7) In place.

Repeat process for all springs

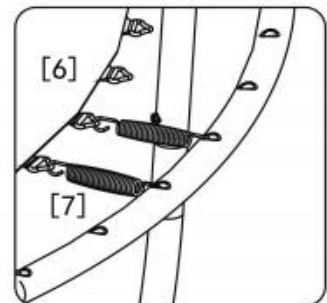
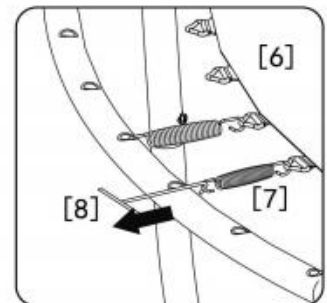

STEP5-Frame Cover Pad Assembly

A.Lay the Frame cover pad over the trampoline so that the springs and the steel frame is covered. Please ensure that the Frame Pad covers all metal parts.

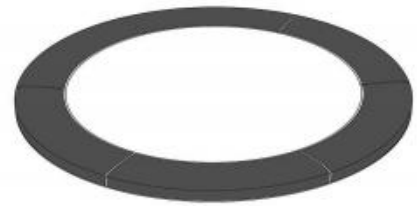

9

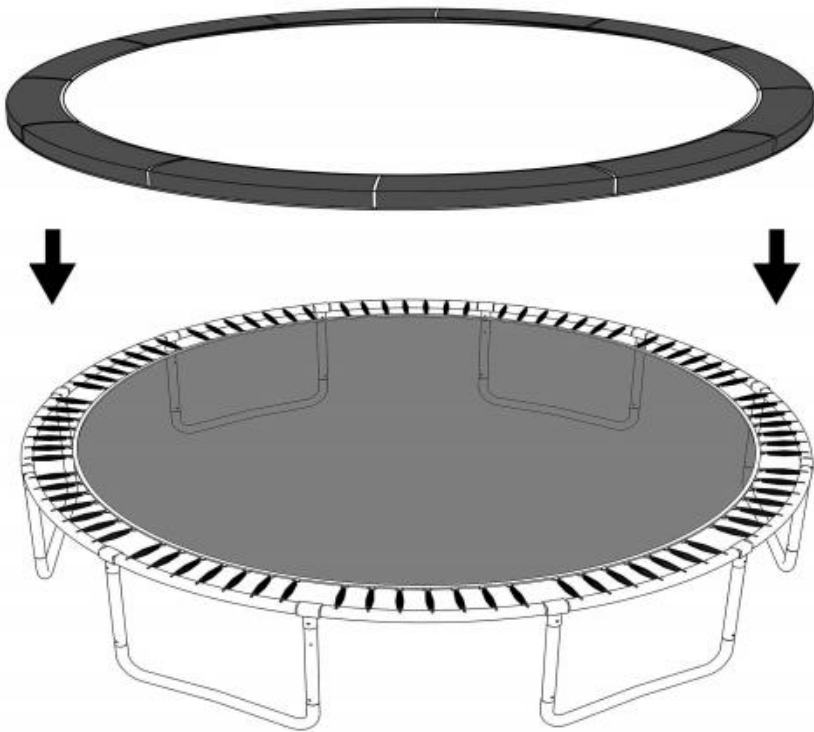

B.Tie the strap located at the under side of the frame pad to the frame.

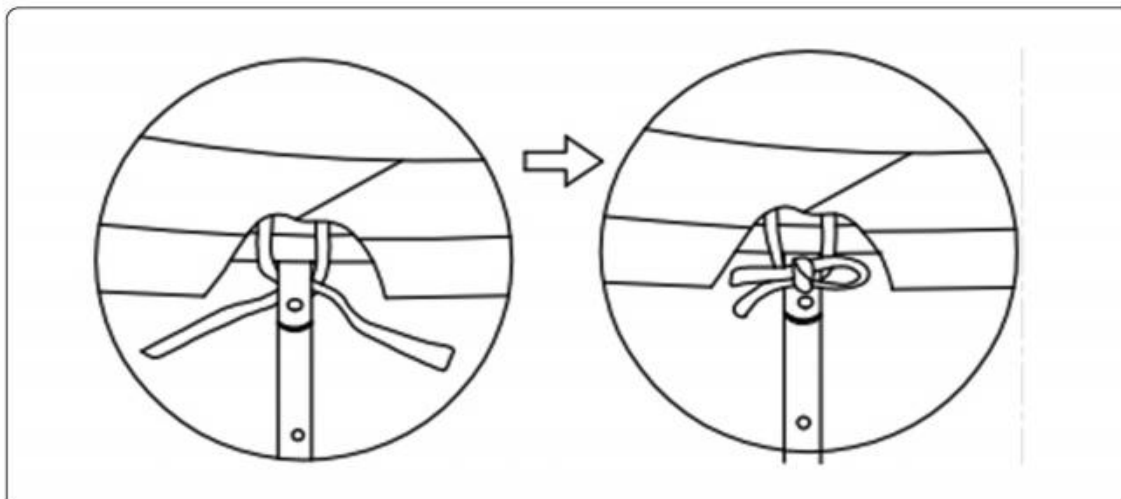

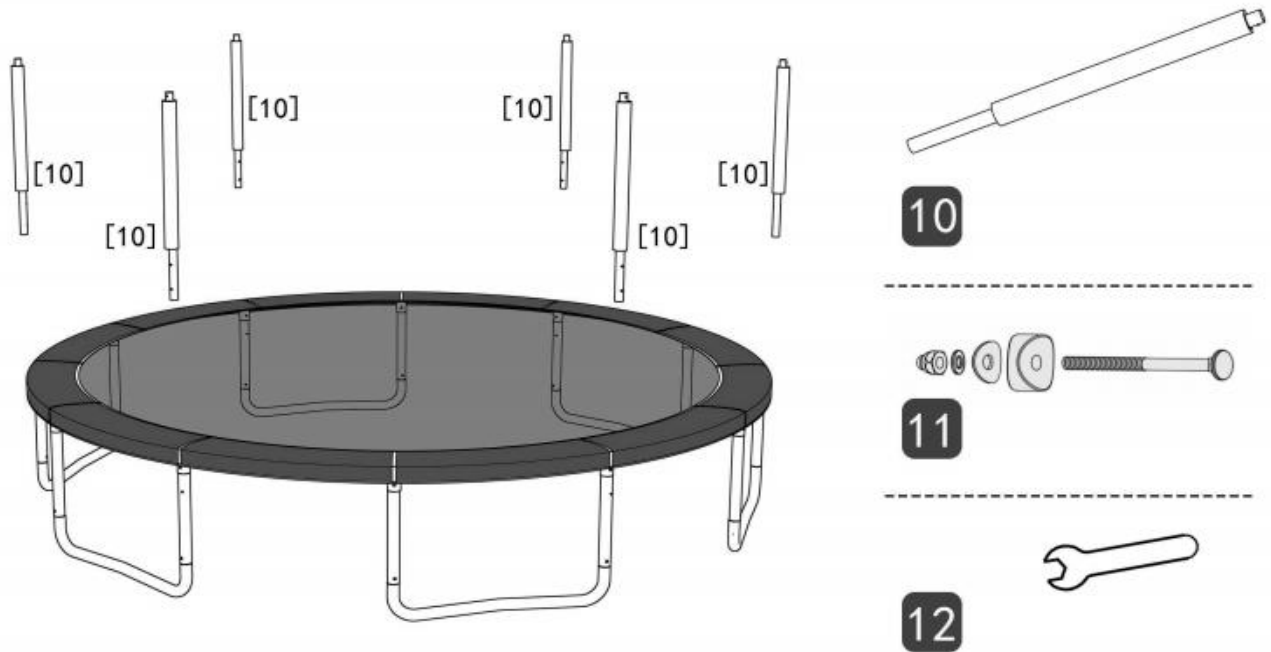

**STEP 6:**

Mount the Bottom Safety Pole(#10) onto the Vertical Leg Extension(#2) using screw(#11) Firm the bolt using the spanner(#12)

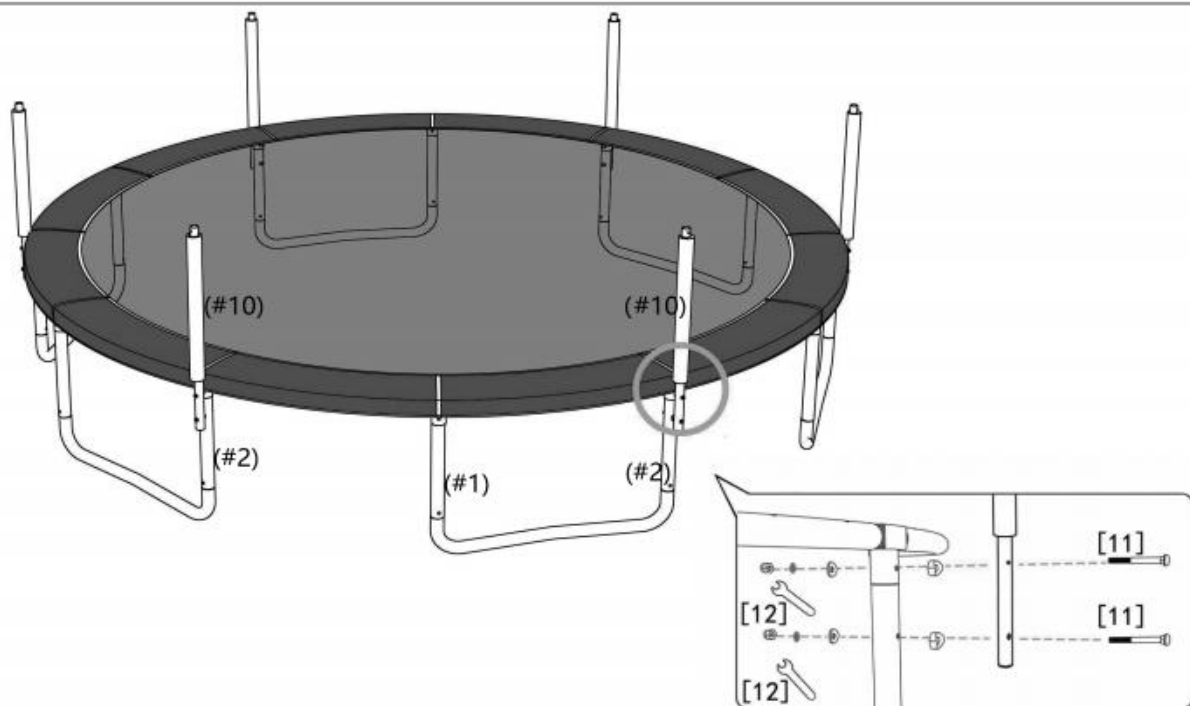

**STEP 7:**

Insert the Up Safety Pole(#13/14) into the top of the Bottom Safety Pole(#10),and then rotate the Up Safety Pole(#13/14) to make the hole position coincide with the marble position of the Bottom Safety Pole (#10) untill the metal marbles pop out and fixed Repeat step 7 to install 6 of the safety pole.

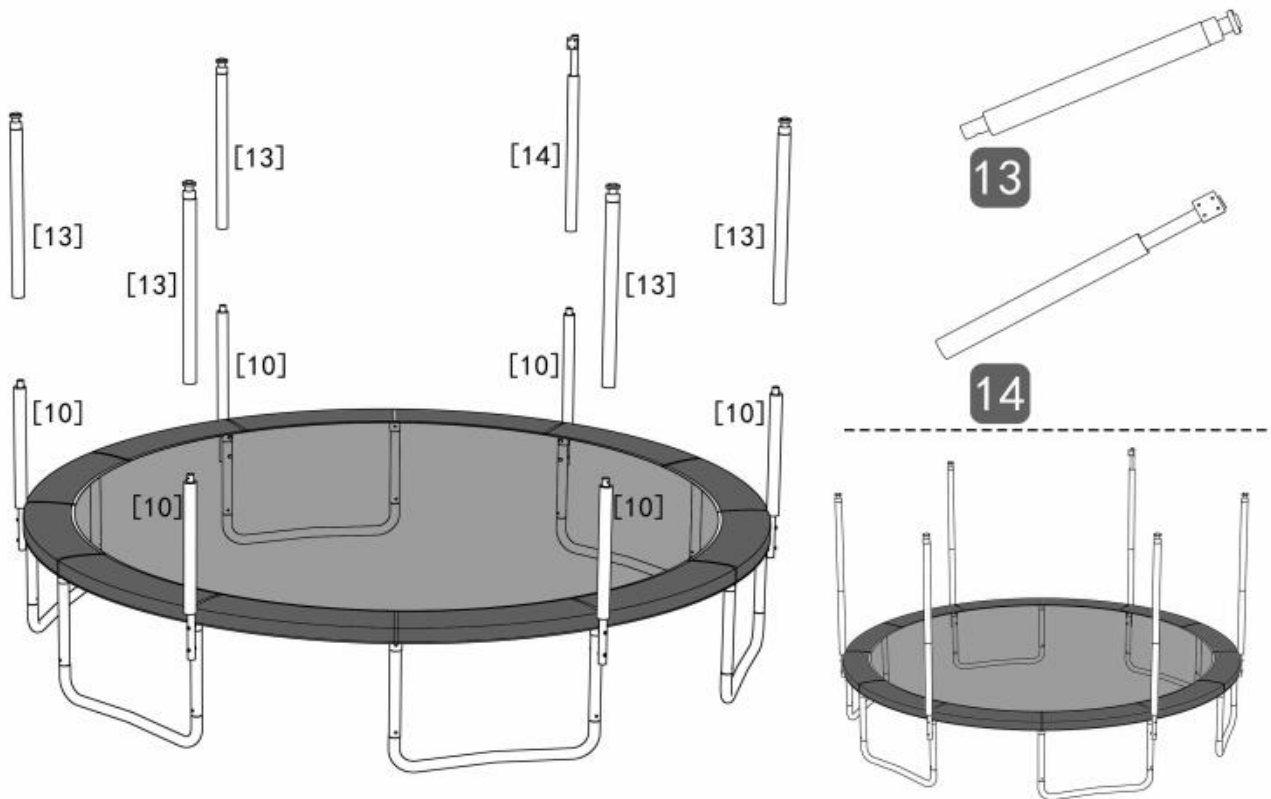
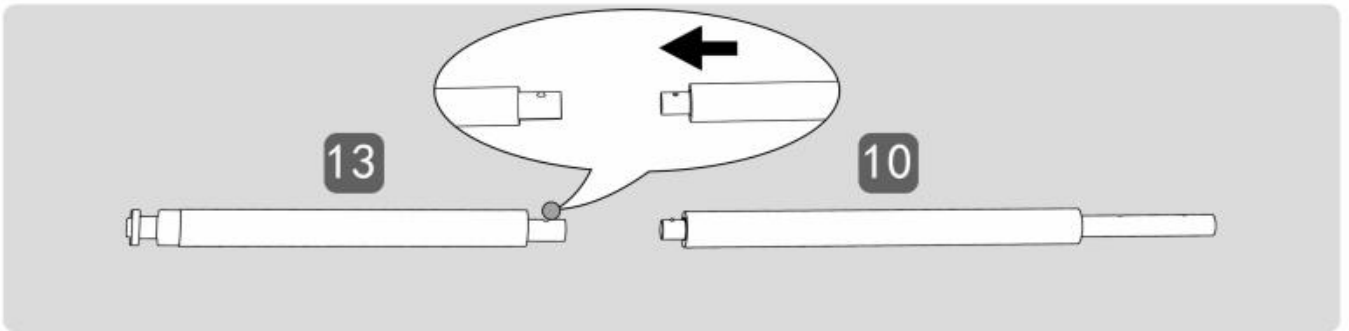

### STEP 8-Secure Safety Net

Put each opening at the top of the safety net(#15) onto the top of the Up Safety Pole(#13/14) till safety net is installed.

Components net ropes(#16),safety net(#15)through the bottom hole components,and parts cross around spring and fixed.

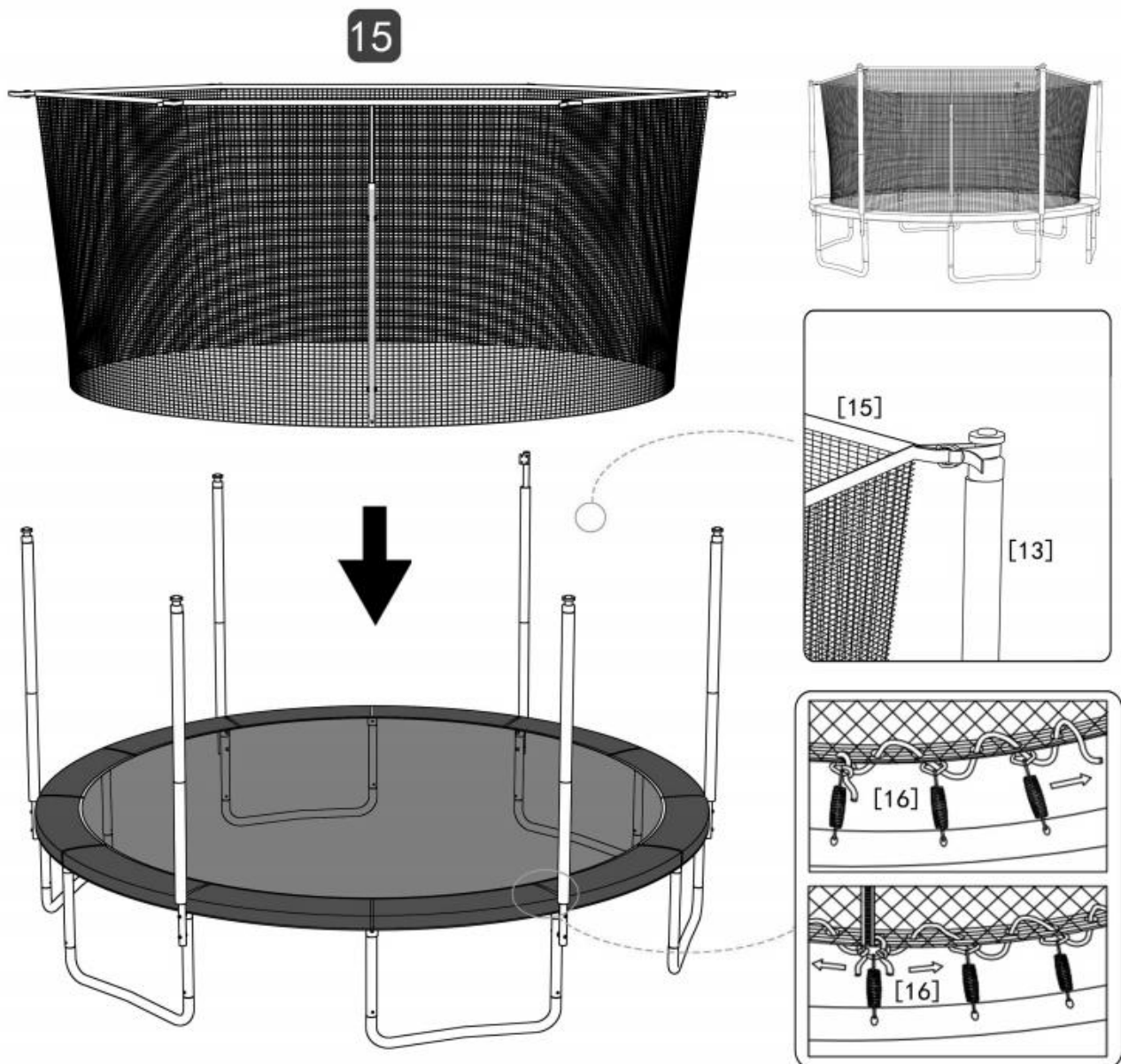

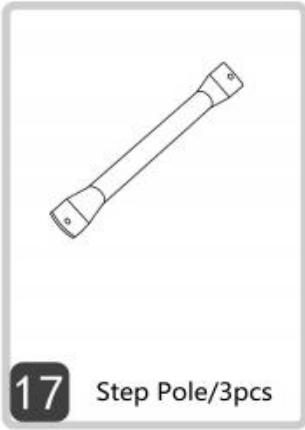

**17** Step Pole/3pcs



**18** Frame Pole/2pcs



**19** Bolt Pack/6pcs

### STEP 9-LADDER ASSEMBLY

Take out the Frame Pole(#18), Step Pole(#17) and screw(#19). And screw the Step Pole(#17) above the Frame Pole(#18) as shown in the figure.

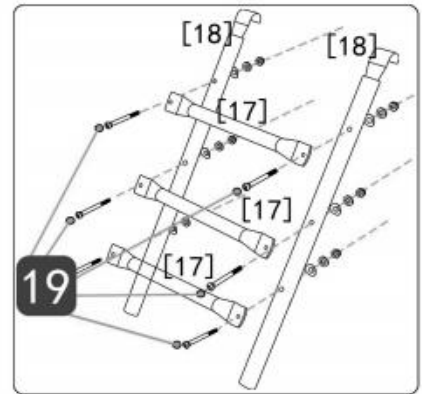
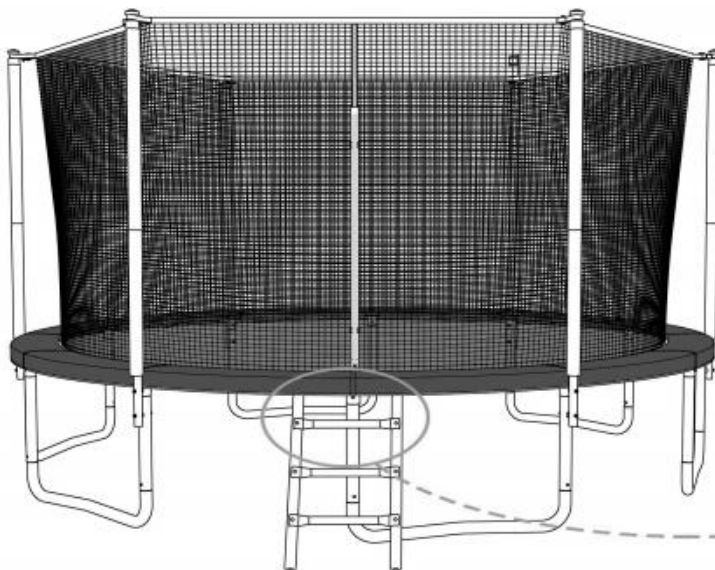

# BASKETBALL HOOP

## INSTALLATION MANUAL

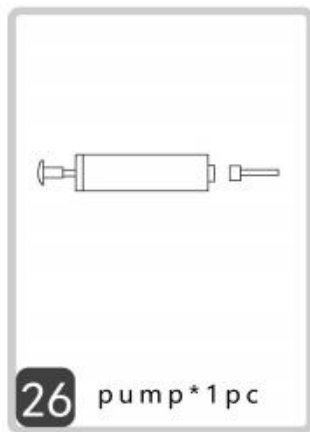
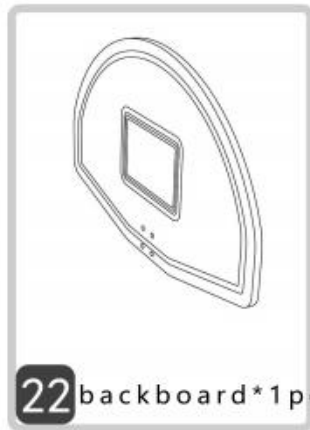
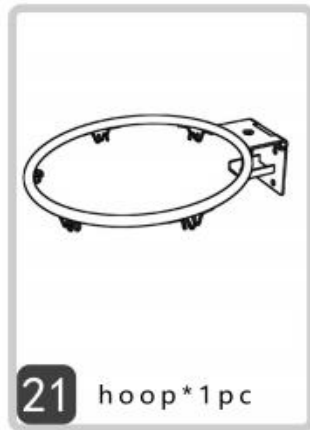

**⚠ WARNING**  
\* Read and follow this installation manual  
\* Adult assembly required

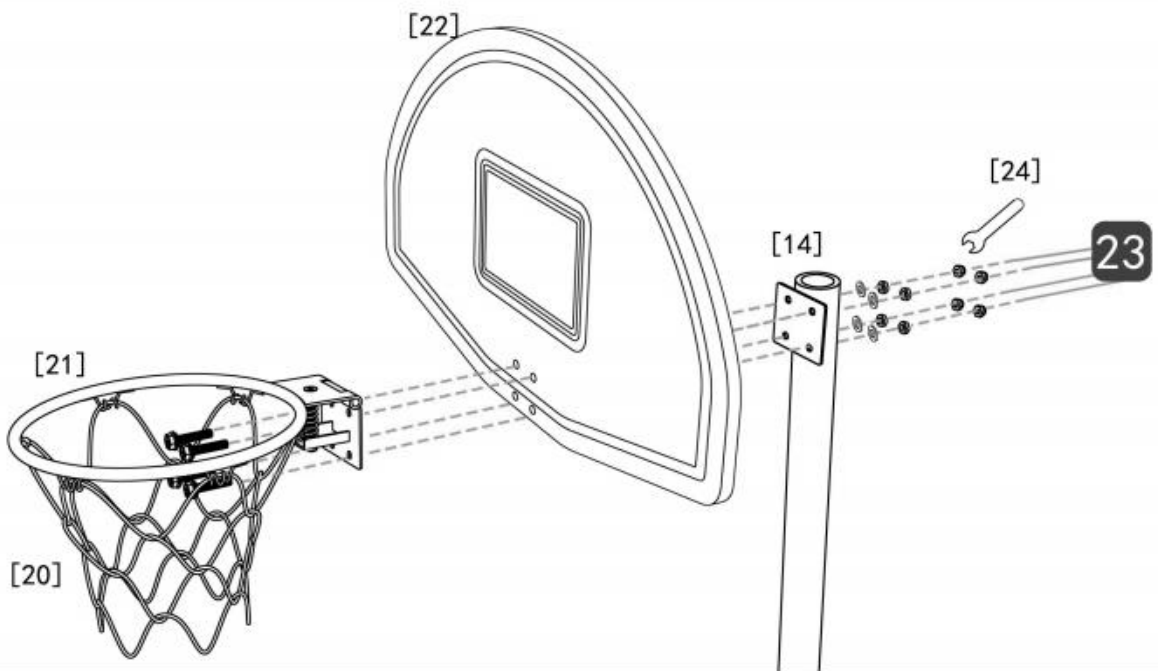

**STEP 10:**

Install the Backboard(#22) and Basketball Net(#20) onto the Backboard Specific Pole(#14),secure them with screw(#23)

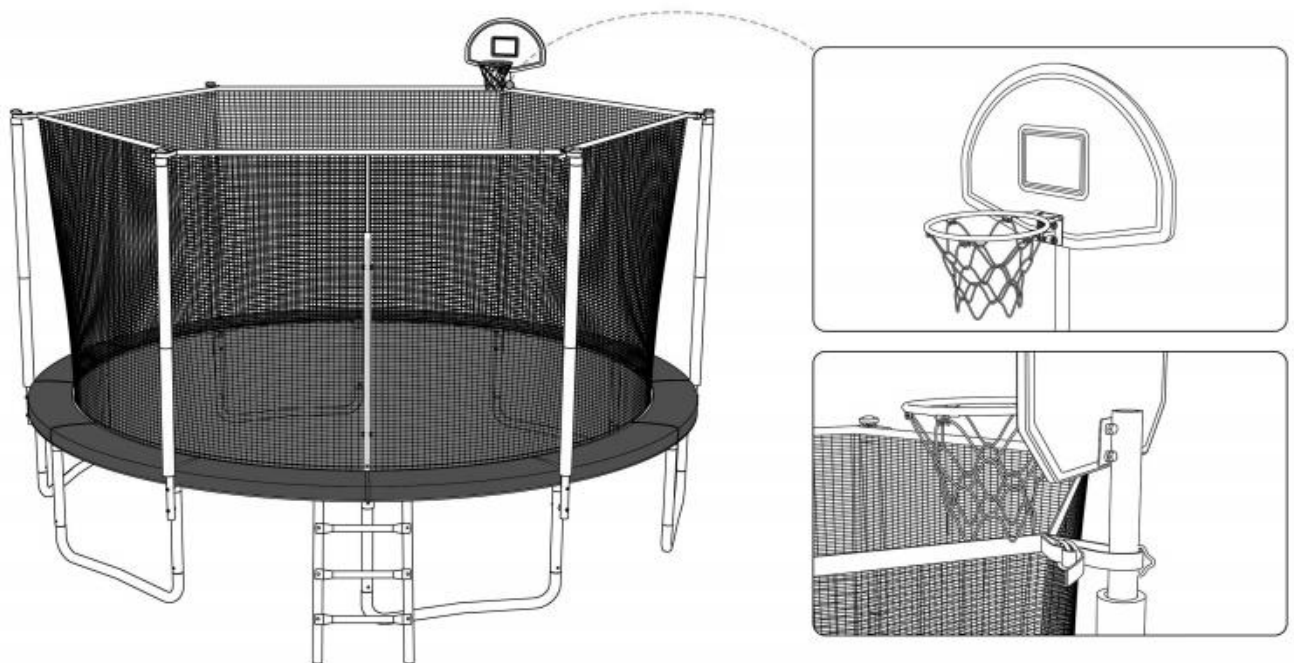

The strap on the safety net passes through the triangle buckle behind the backboard  
 △



## **CARE AND MAINTENANCE**

This trampoline was designed and manufactured with quality materials and craftsmanship. If proper care and maintenance is provided. It will provide all jumpers with years of exercise, fun, and enjoyment as well as reduce the risk of injury. Please follow the guidelines listed below:

This trampoline is designed to with hold a certain amount of weight and use . Please make sure that only one person at any one time uses the trampoline. Also, the person should weight less than **330lbs (150kgs)** jumpers should either wear socks, gymnastics shoes, or be barefoot .

When using the trampoline. Please be aware that street shoes or tennis shoes should NOT be worn while using the trampoline in order to prevent the trampoline mat from getting cut or damaged please do not allow any pets onto the mat. Also, jumpers should remove all sharp objects from their person prior to using the trampoline. Any type of sharp or pointed objects should be kept off the trampoline mat at all times.

Always inspect the trampoline before each use for worn, abused or missing parts. A number of conditions could arise that may increase your chances of getting injured. Please be aware of:

Punctures, holes, or tears in the trampoline mat

Sagging trampoline mat

Loose stitching or any kind of deterioration of the mat

Bent or broken frame parts, such as the legs

Broken, missing, or damaged springs

Damaged, missing, or Insecurely attached frame pad

Protrusions of any types (especially sharp types) on the frame, springs, or mat

## **CARE AND MAINTENANCE**

### **WINDY CONDITIONS**

In severe wind Situations, the trampoline can be blown about. If you expect windy weather conditions, the trampoline should be moved to a sheltered area or disassembled. Another option is to tie the round, outside portion (top frame) of the trampoline to the ground using ropes and stakes.

To ensure security, at least three (3) tie downs should be used. Do not just secure the legs of the trampoline to the ground because they can pull out the frame sockets.

### **MOVING THE TRAMPOLINE**

If you need to move the trampoline, two people should be used. All connector points should be wrapped secured with weather resistant tape, such as duct tape. This will keep the frame intact during the move and prevent the connector points from dislocating and separating. When moving, lift the trampoline slightly off the ground and keep it horizontal to the ground. For any type of other move, you should disassemble the trampoline.

IF YOU FIND ANY OF THE PREVIOUS CONDITIONS, OR ANYTHING ELSE THAT YOU FEEL COULD CAUSE HARM TO ANY USER, THE TRAMPOLINE SHOULD BE DISASSEMBLED OR SECURED FROM USE UNTIL THE CONDITIONS HAS BEEN RESOLVED.

**THE PRODUCT SPECIFICATIONS AND INFORMATION MENTIONED IN THESE OPERATING INSTRUCTIONS ARE FOR REFERENCE ONLY, AND ARE SUBJECT TO CHANGE WITHOUT NOTICE.**



