

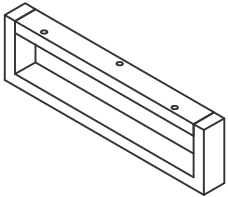

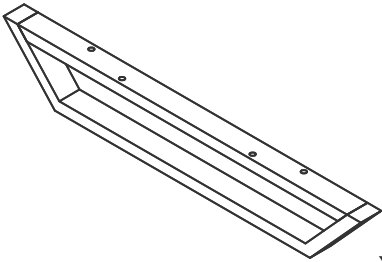

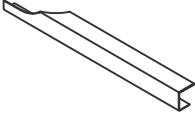

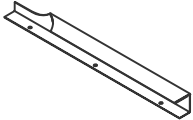

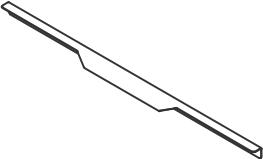
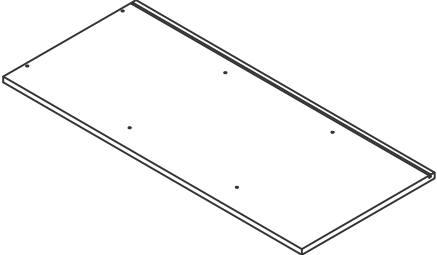
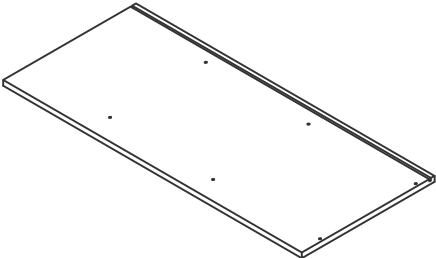
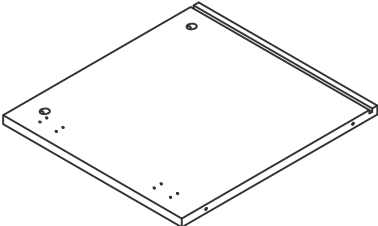
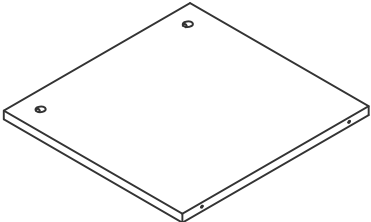
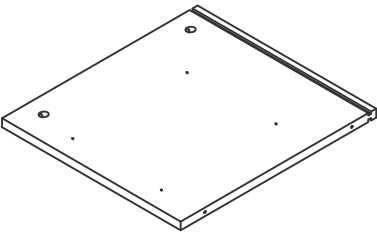
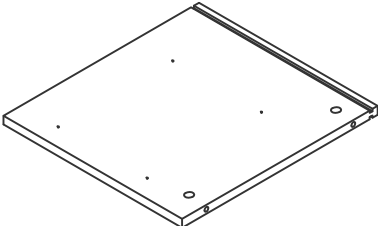
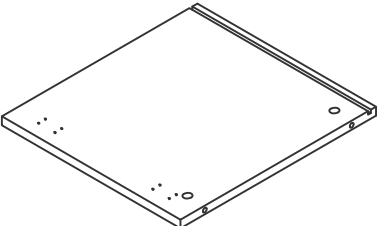
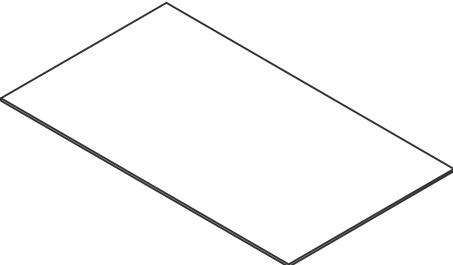
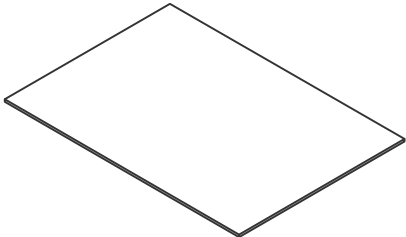
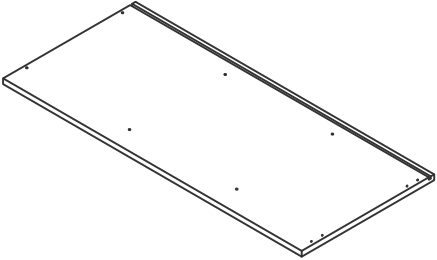
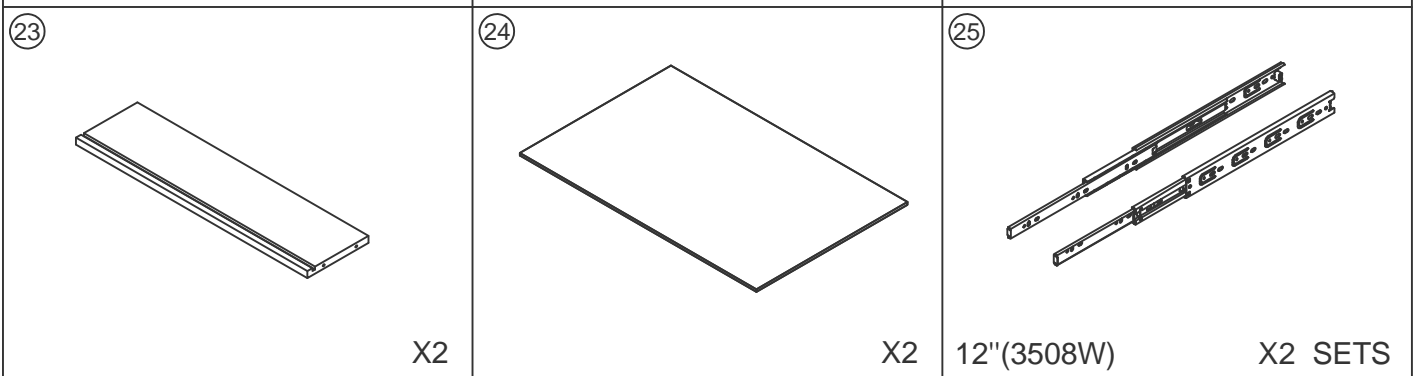
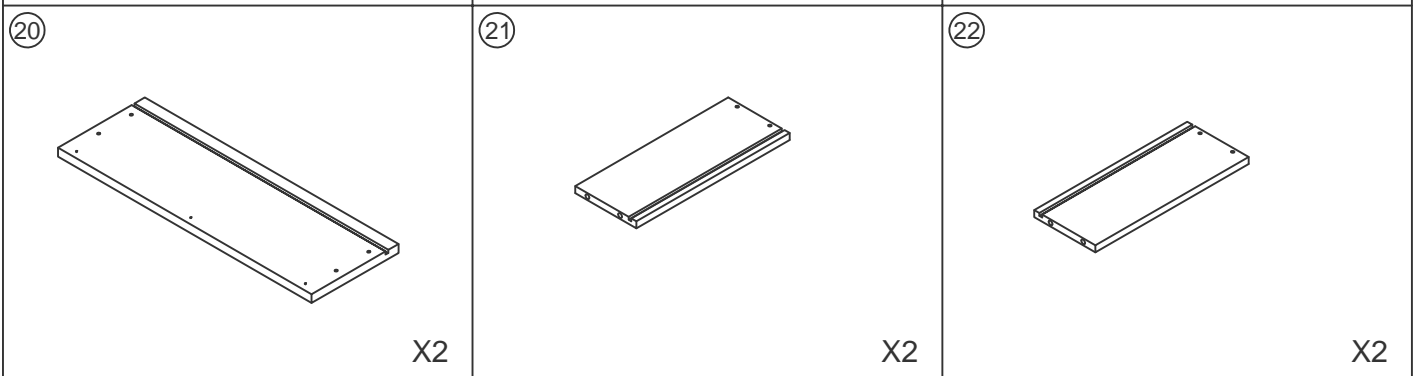
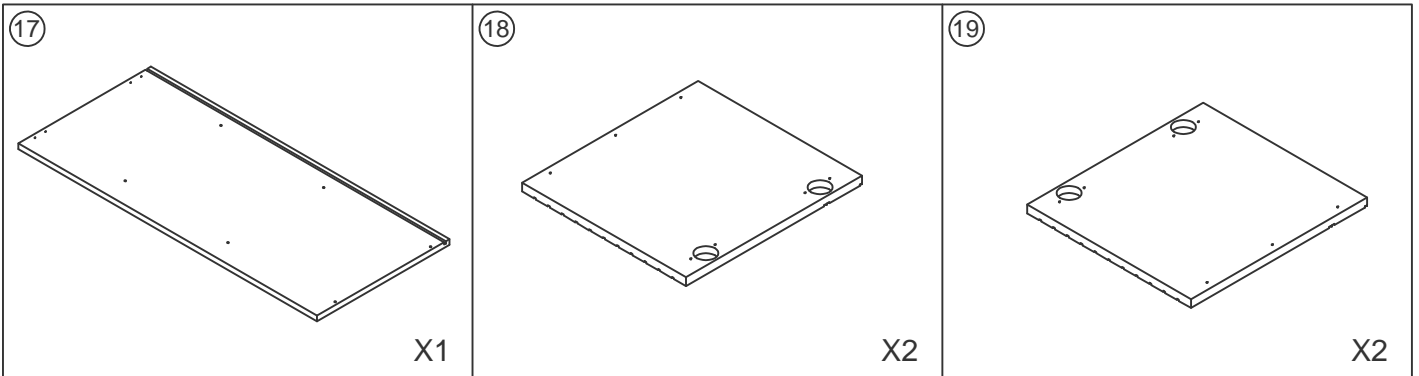







<p>①</p>  <p>X2</p>	<p>②</p>  <p>X1</p>	<p>③</p>  <p>X2</p>
<p>④</p>  <p>X2</p>	<p>⑤</p>  <p>X2</p>	<p>⑦</p>  <p>X1</p>
<p>⑧</p>  <p>X1</p>	<p>⑨</p>  <p>X1</p>	<p>⑩</p>  <p>X2</p>
<p>⑪</p>  <p>X1</p>	<p>⑫</p>  <p>X1</p>	<p>⑬</p>  <p>X1</p>
<p>⑭</p>  <p>X2</p>	<p>⑮</p>  <p>X1</p>	<p>⑯</p>  <p>X1</p>



<p>Ⓐ M5X42</p>	<p>Ⓑ Ø15X10</p>	<p>Ⓒ M6X30</p>	<p>Ⓓ M5X40</p>	<p>Ⓔ M3.5X14</p>	<p>Ⓕ</p>	<p>Ⓖ</p>	<p>Ⓗ</p>	<p>Ⓙ M6XØ28</p>
 <p>20 PCS</p>	 <p>20 PCS</p>	 <p>10 PCS</p>	 <p>22 PCS</p>	 <p>98 PCS</p>	 <p>4 PCS</p>	 <p>8 PCS</p>	 <p>12 PCS</p>	 <p>6 PCS</p>
<p>Ⓚ M3.5X12</p>	<p>Ⓛ</p>	<p>Ⓜ</p>	<p>4#</p>					
 <p>14 PCS</p>	 <p>2 PCS</p>	 <p>2 PCS</p>	 <p>1 PCS</p>	 <p>1 PCS</p>				

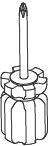
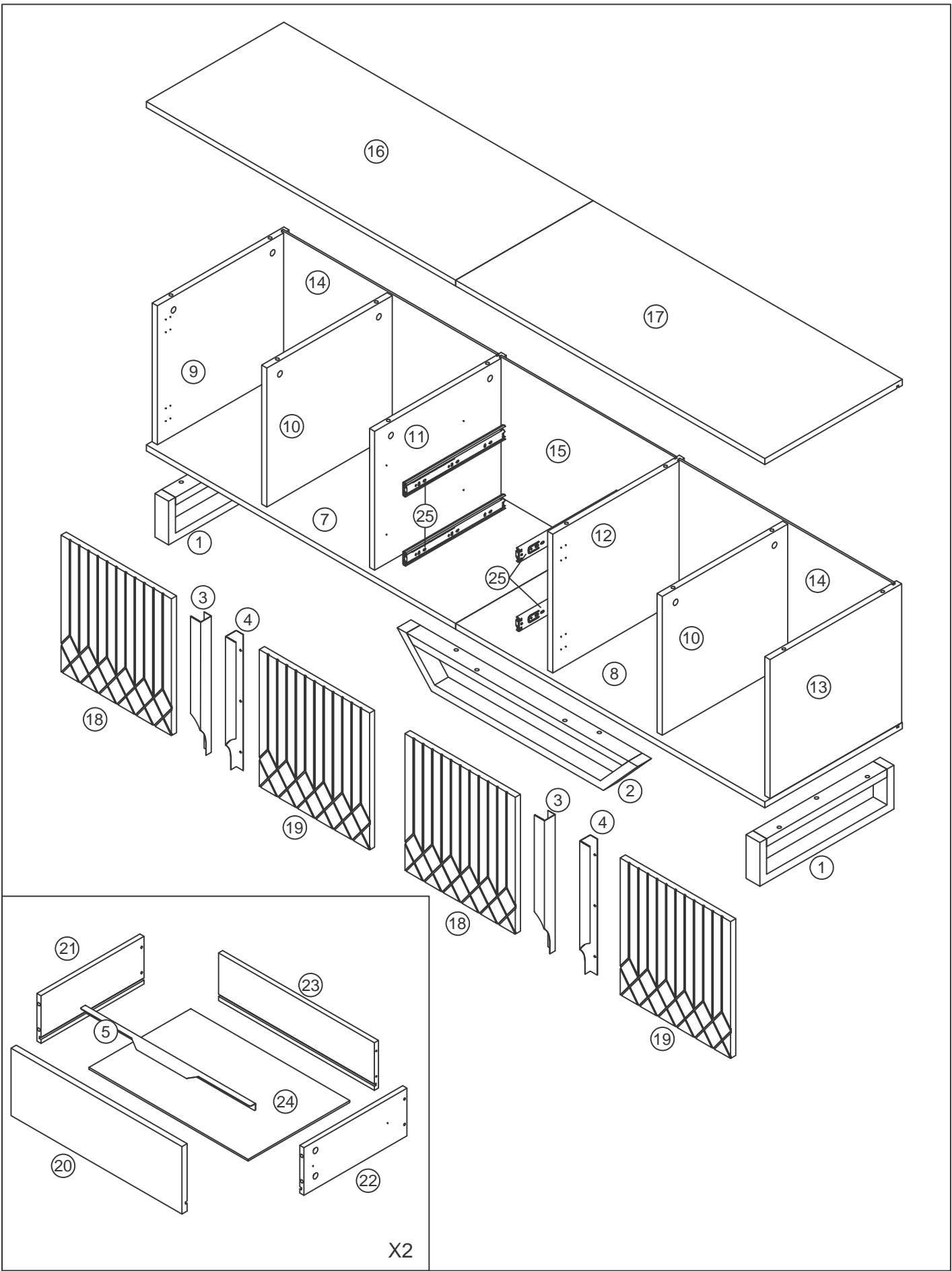

## CAM LOCK FASTENING SYSTEM

This Cam Lock Fastening System will be used throughout the assembly process.

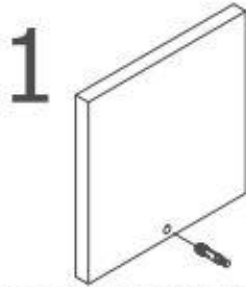

1 Press CAM BOLT into hole.

2

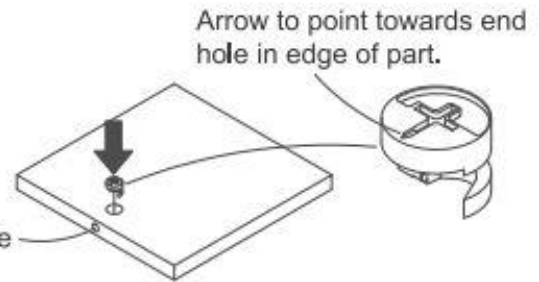

End hole

Press CAM LOCK into hole.

3

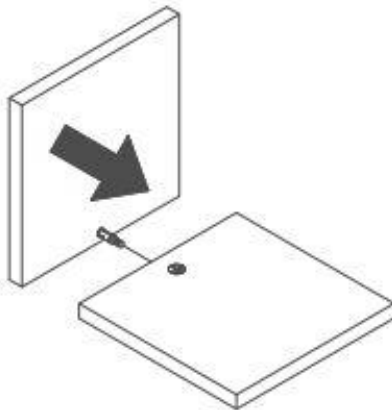

Press parts together so CAM BOLT inserts into edge hole.

4

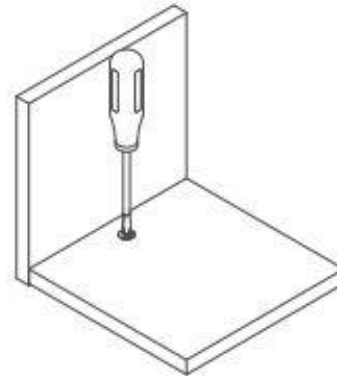

Using a screwdriver, turn the CAM LOCK clockwise to lock the CAM LOCK and CAM BOLT into their holes and fastening parts together.

### M5X42

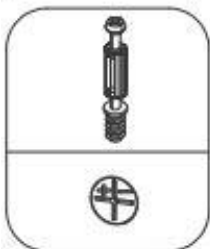

Notice: Proper orientation of CAM LOCK

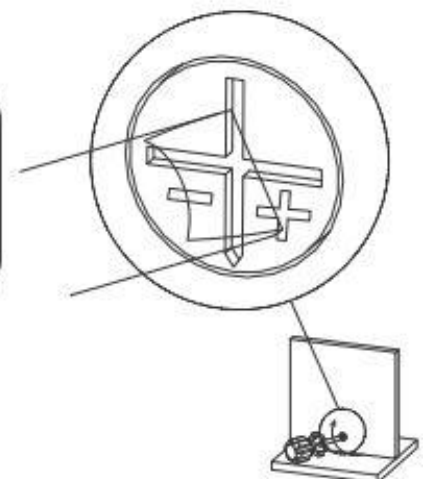
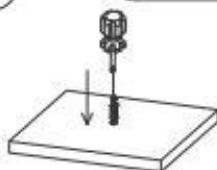

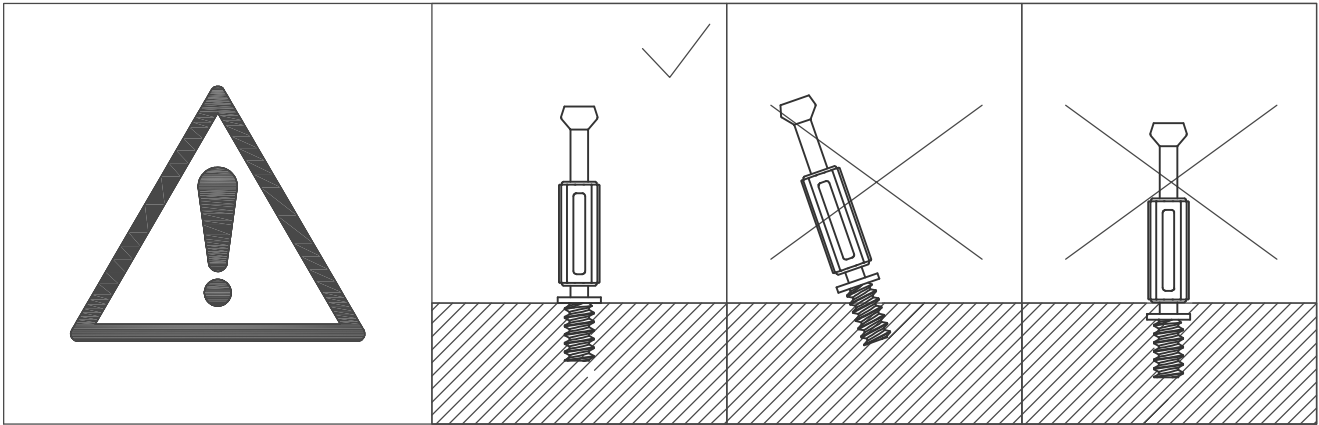

Slides Must Be Separated Before Assembly,  
After Separated, Set Aside Until Needed for Assembly.

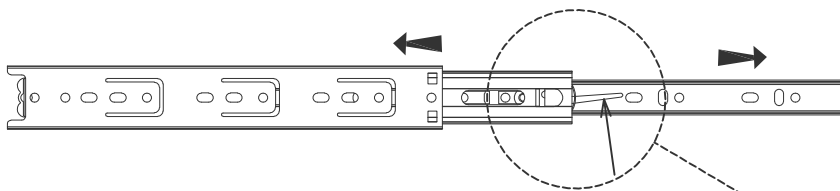

STEP1: Extend slide

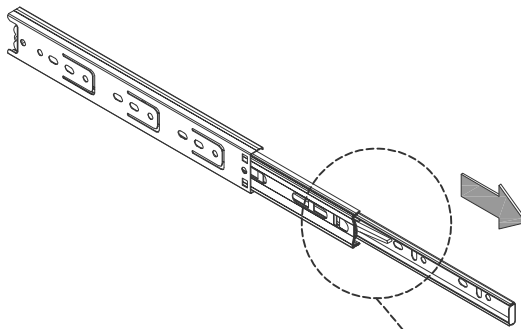

STEP2: Push Lever UP

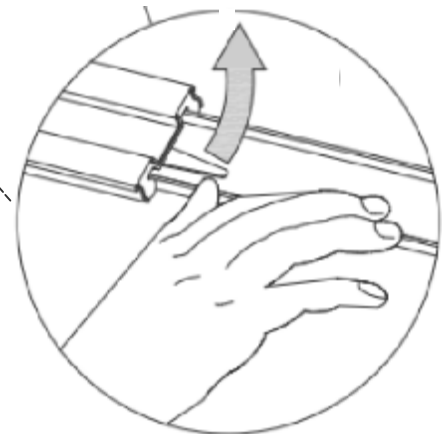

STEP3: Remove Runner

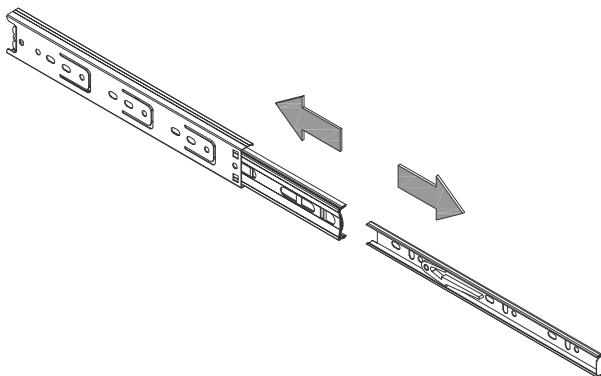

1

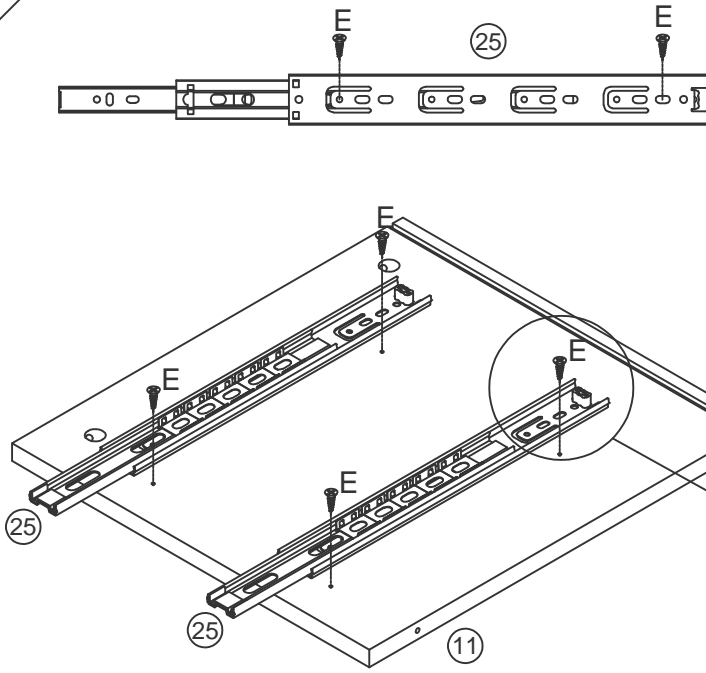

(E) M3.5X14



4 PCS

2

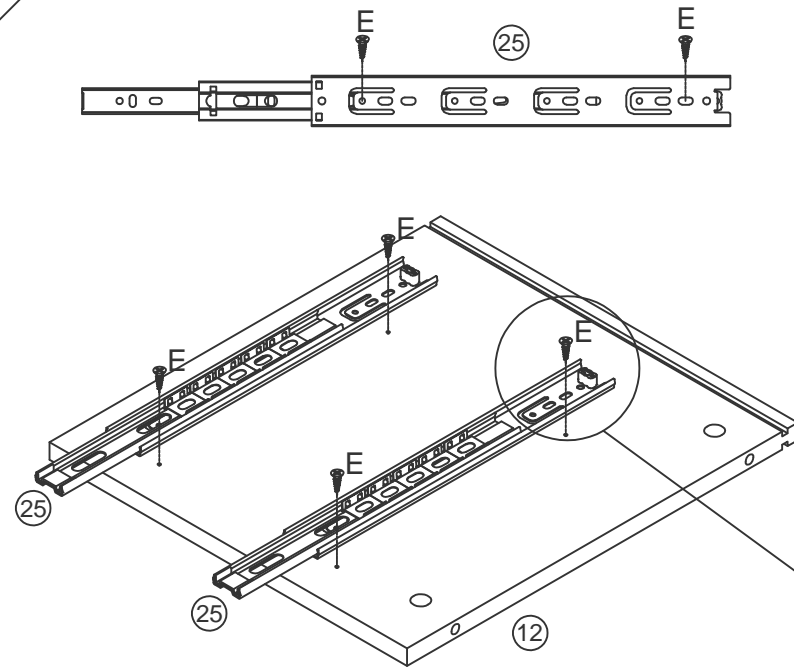





(E) M3.5X14

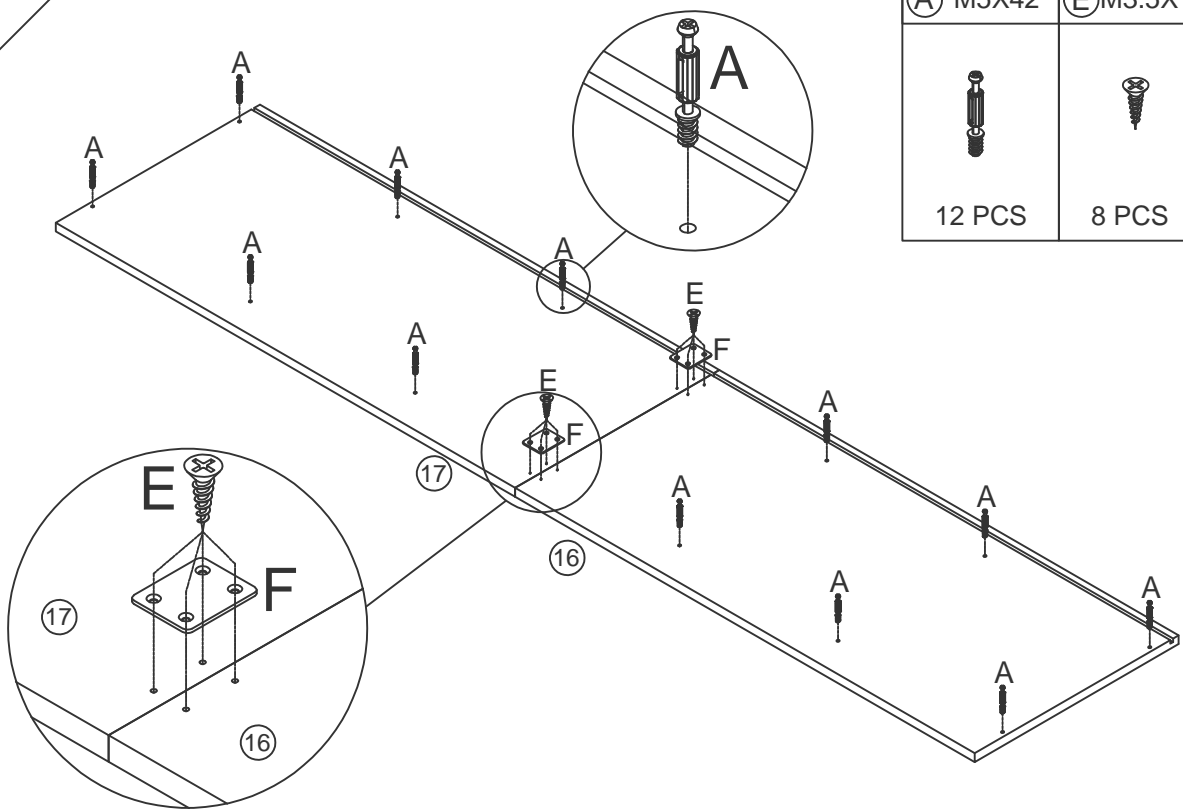

4 PCS

3



(A) M5X42	(E) M3.5X14	(F)
		
12 PCS	8 PCS	2 PCS

4

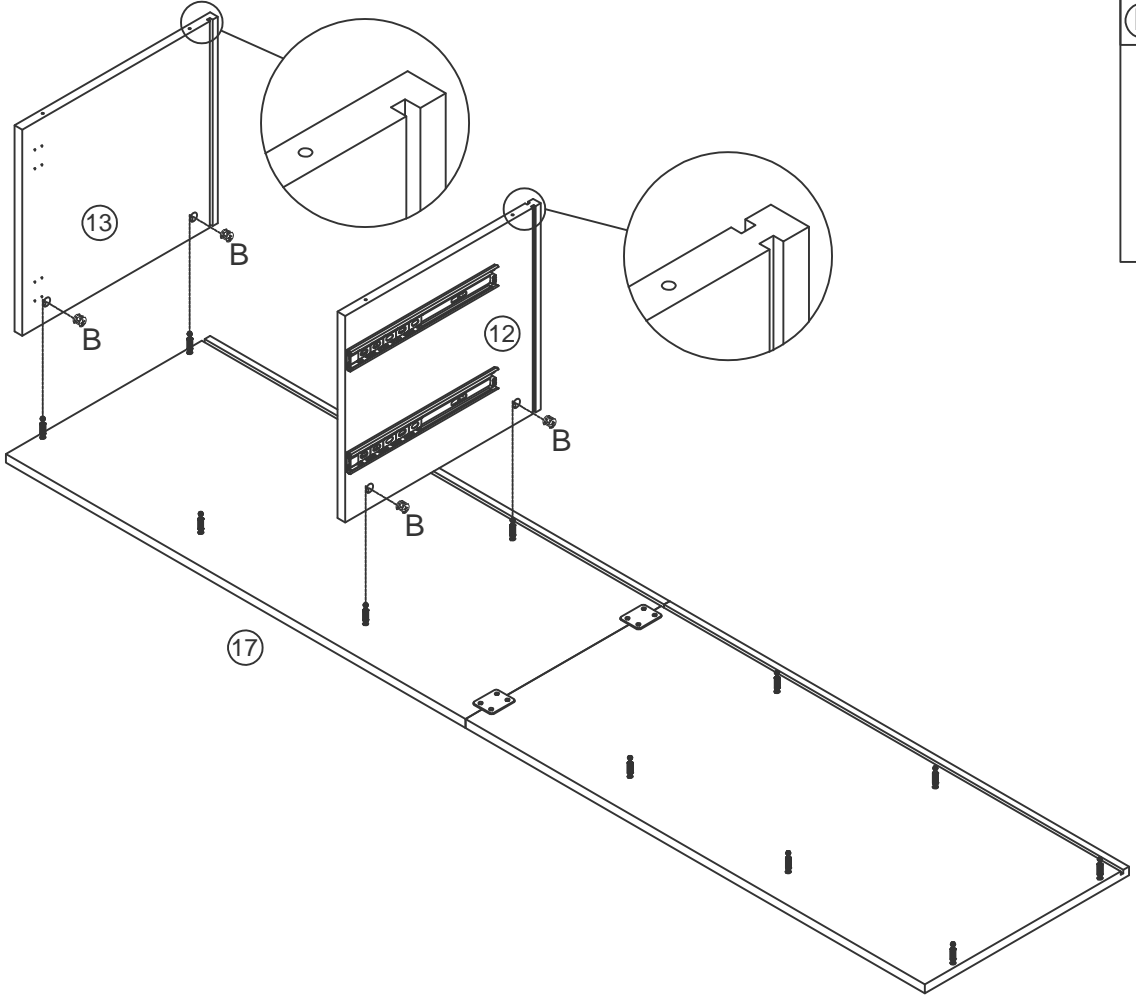

(B) Ø15X10

4 PCS



5

(B) Ø15X10



8 PCS

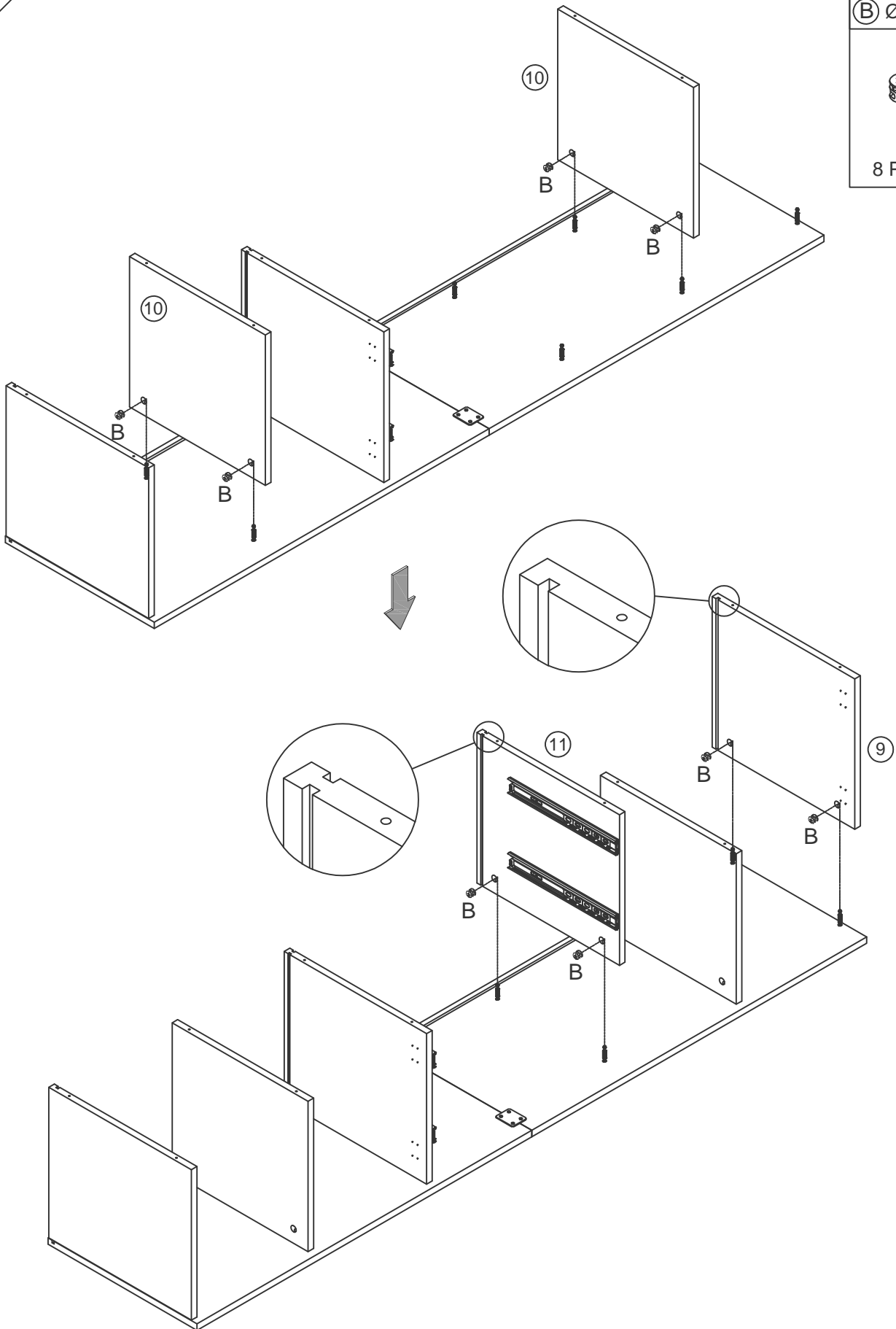

6

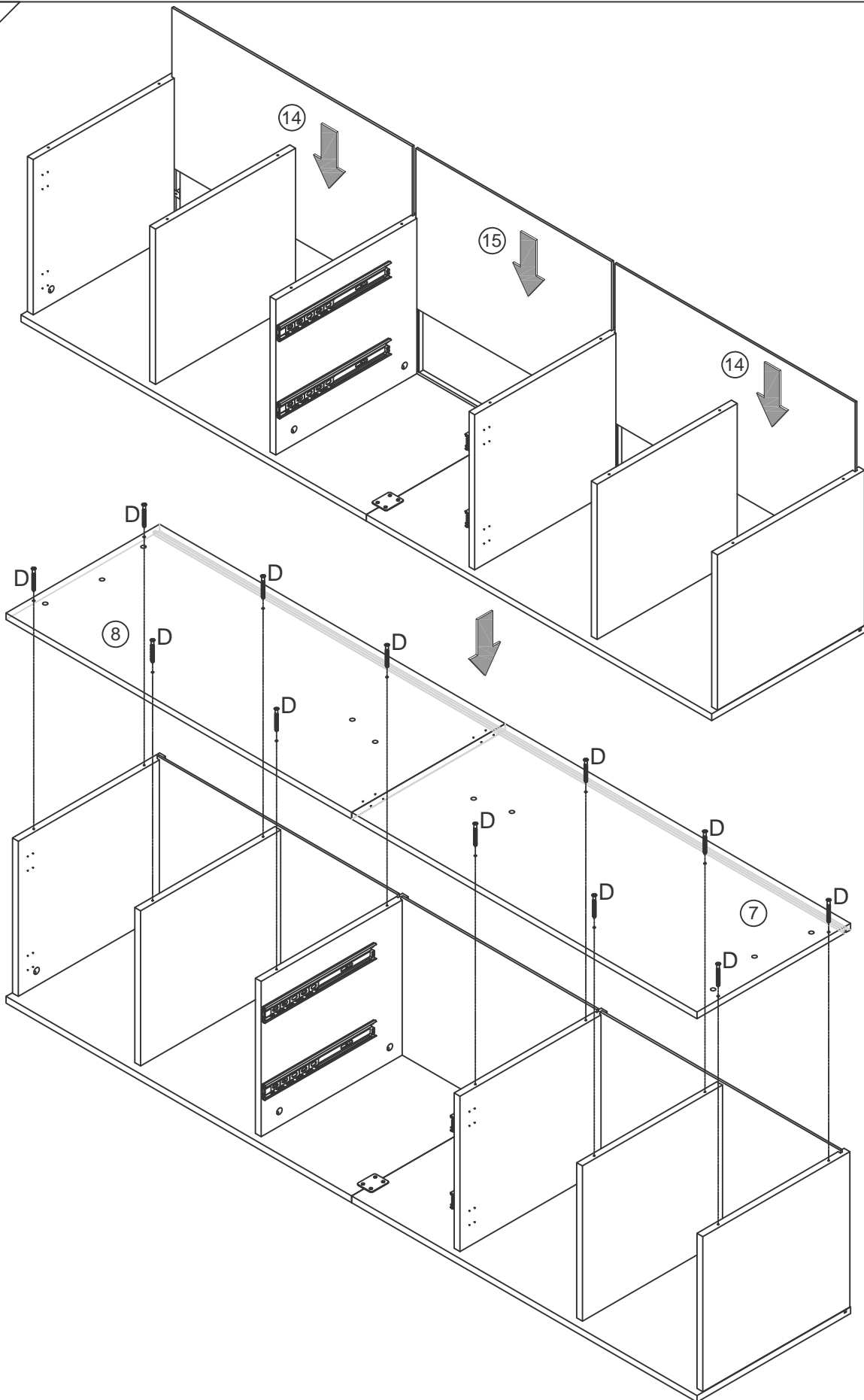



ⓓ M5X40



12 PCS

7

Ⓔ M3.5X14	Ⓕ
	
8 PCS	2 PCS

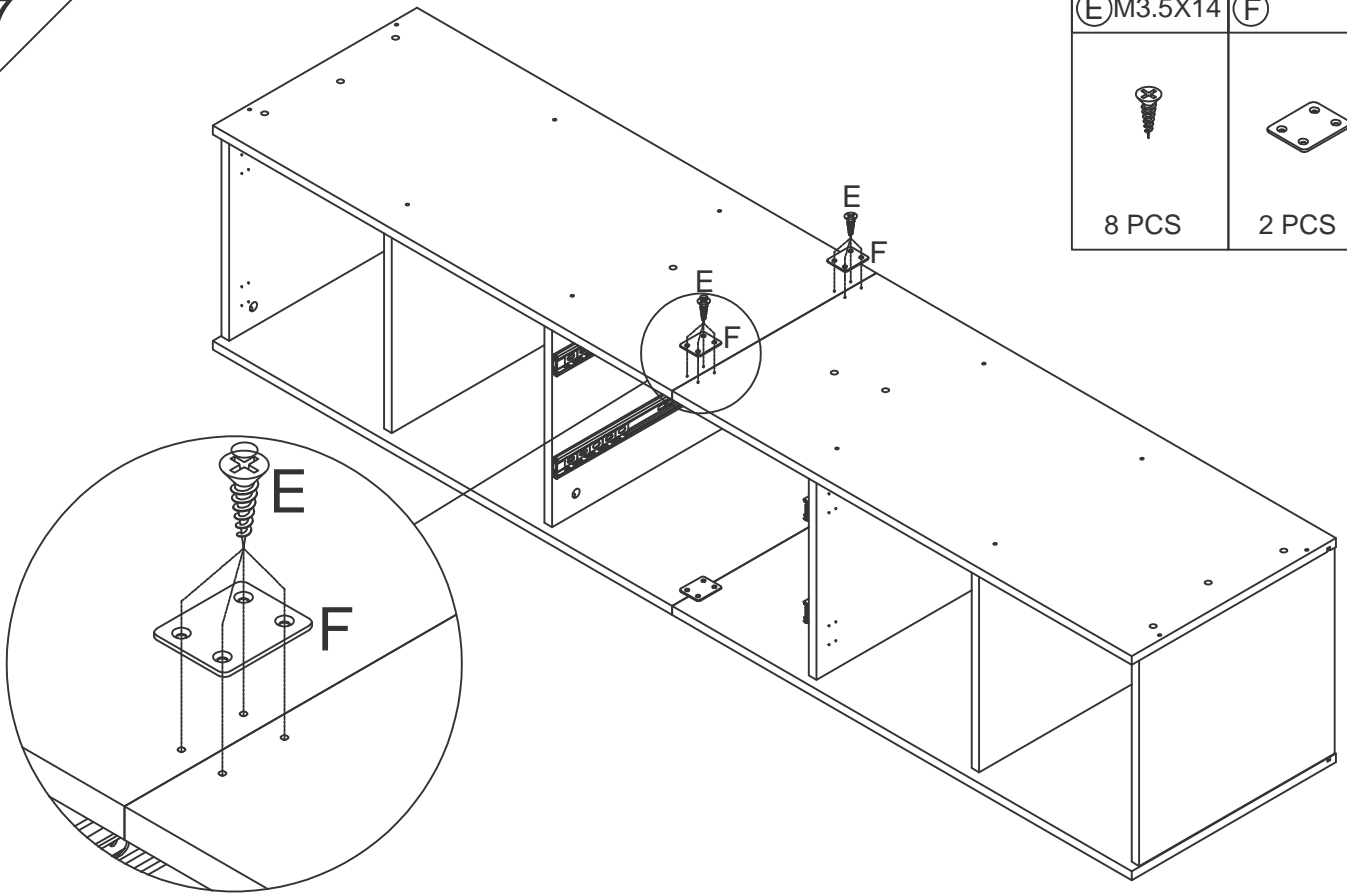

8

Ⓒ M6X30

10 PCS

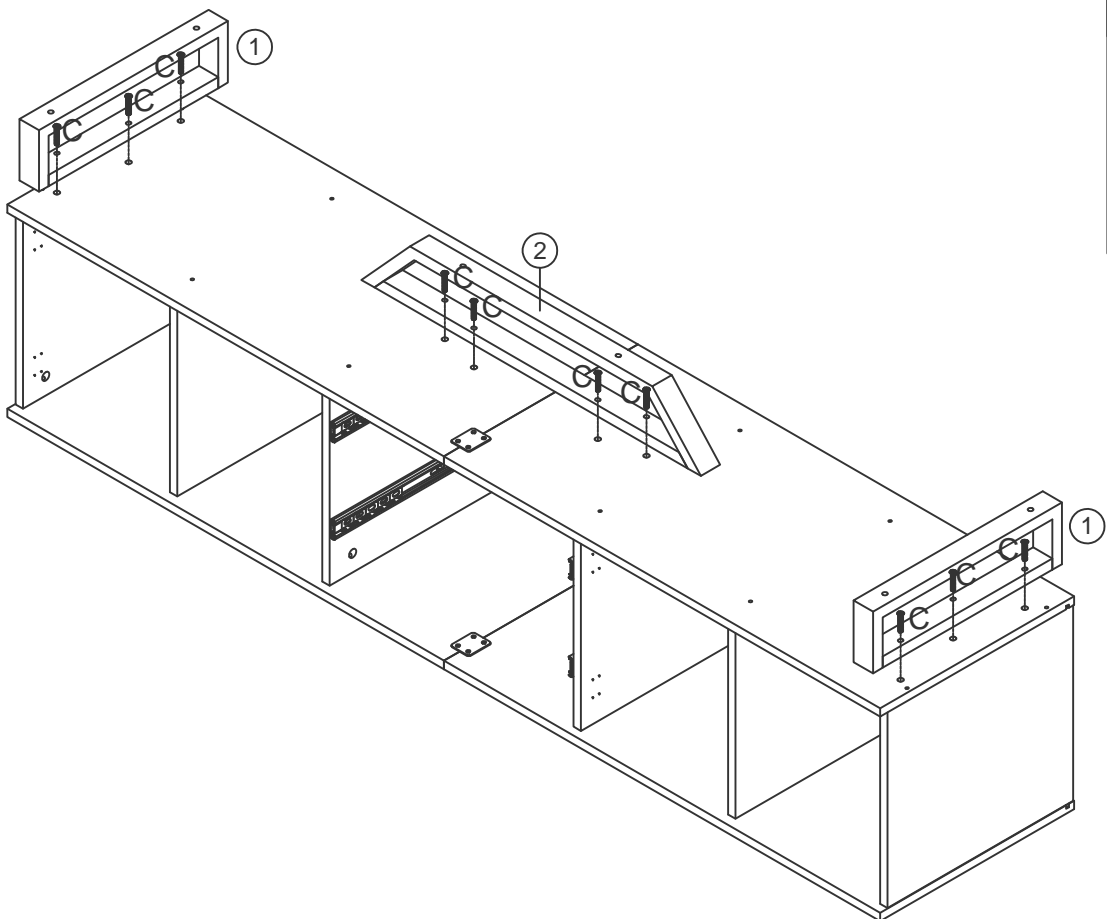

9

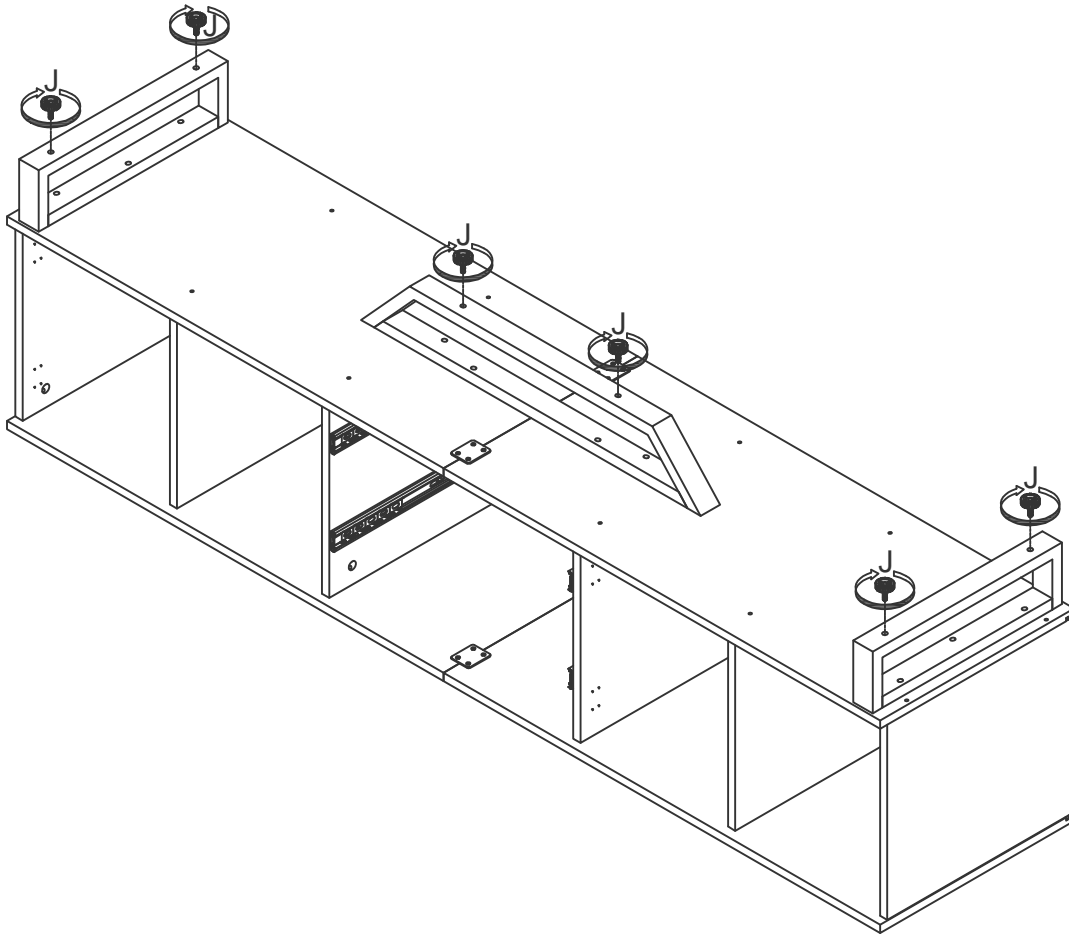

ⓐ M6XØ28



6 PCS

10

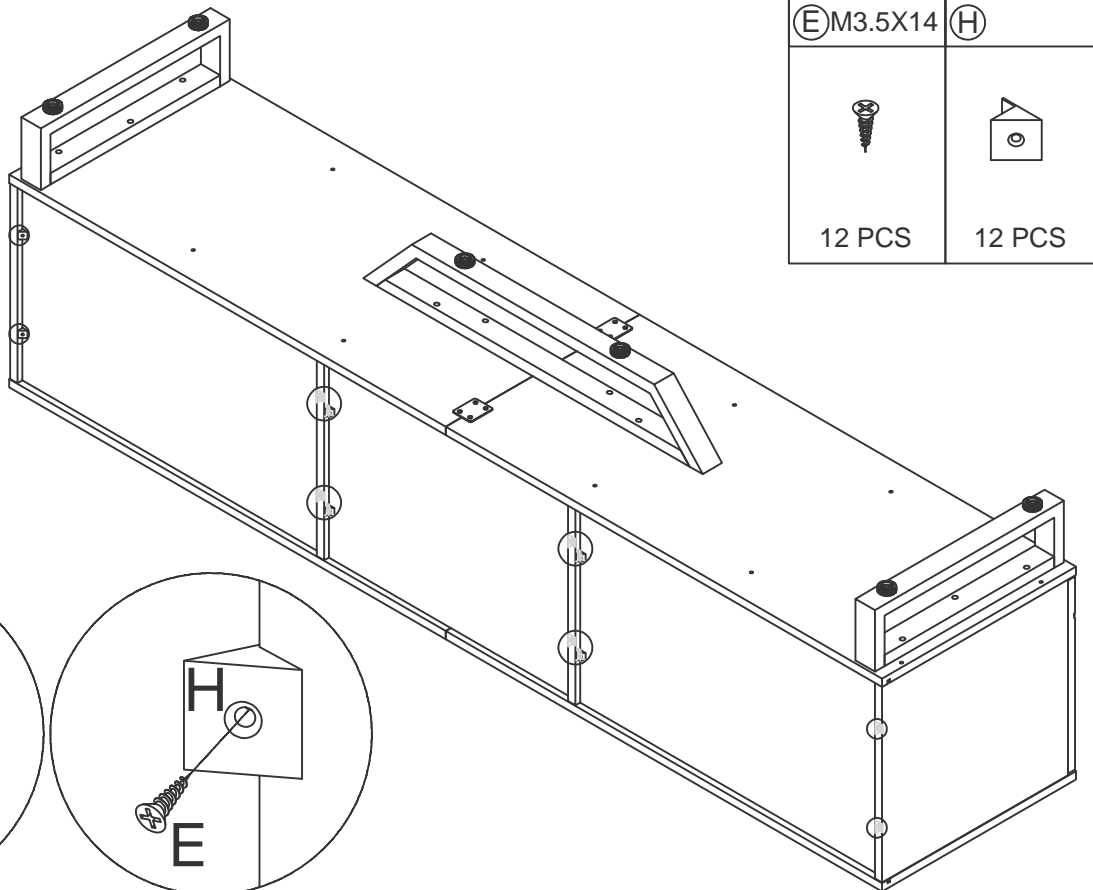

ⓐ M3.5X14

ⓑ







12 PCS

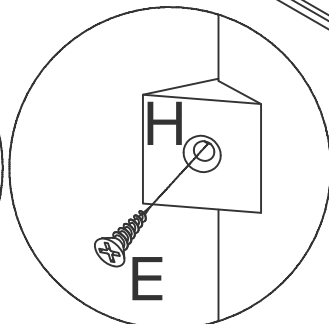
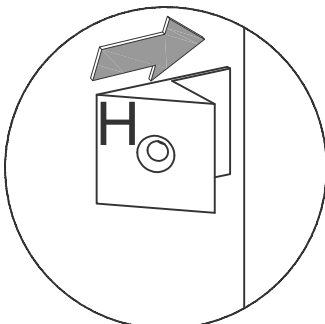

12 PCS



11

(A) M5X42	(B) Ø15X10	(D) M5X40	(K) M3.5X12
			
8 PCS	8 PCS	8 PCS	14 PCS

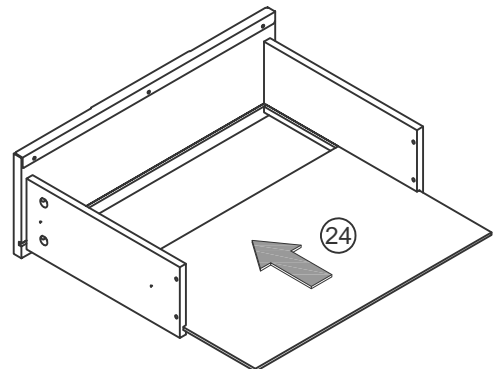
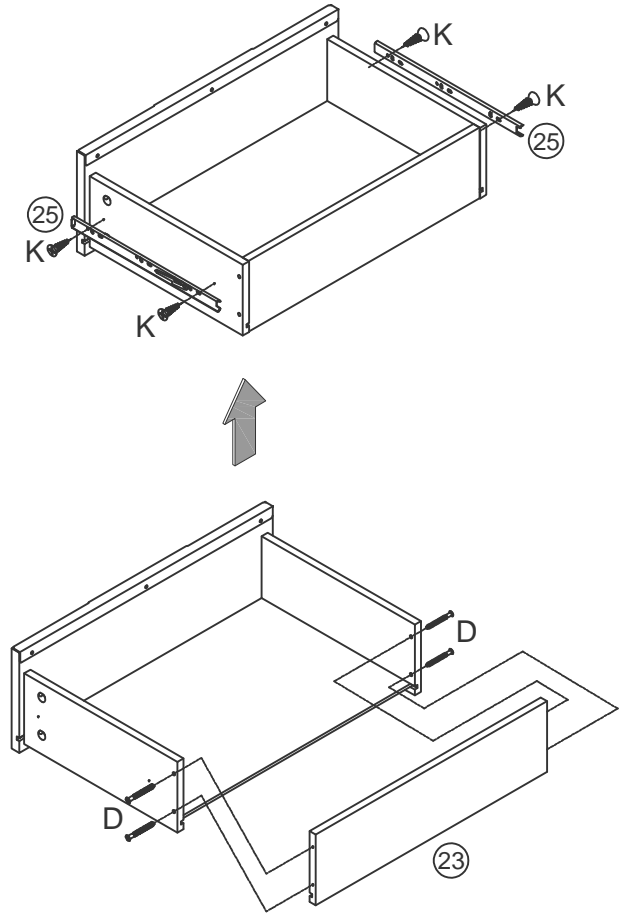
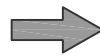
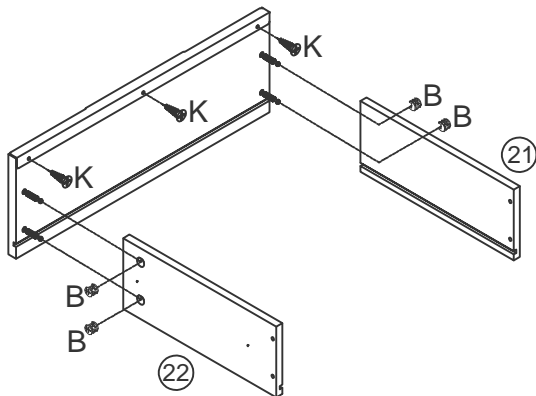
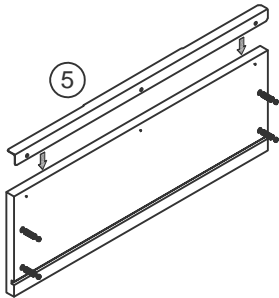
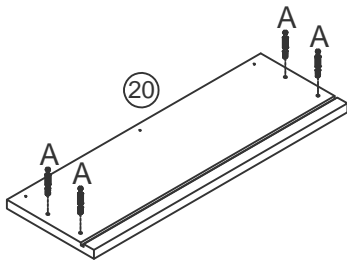

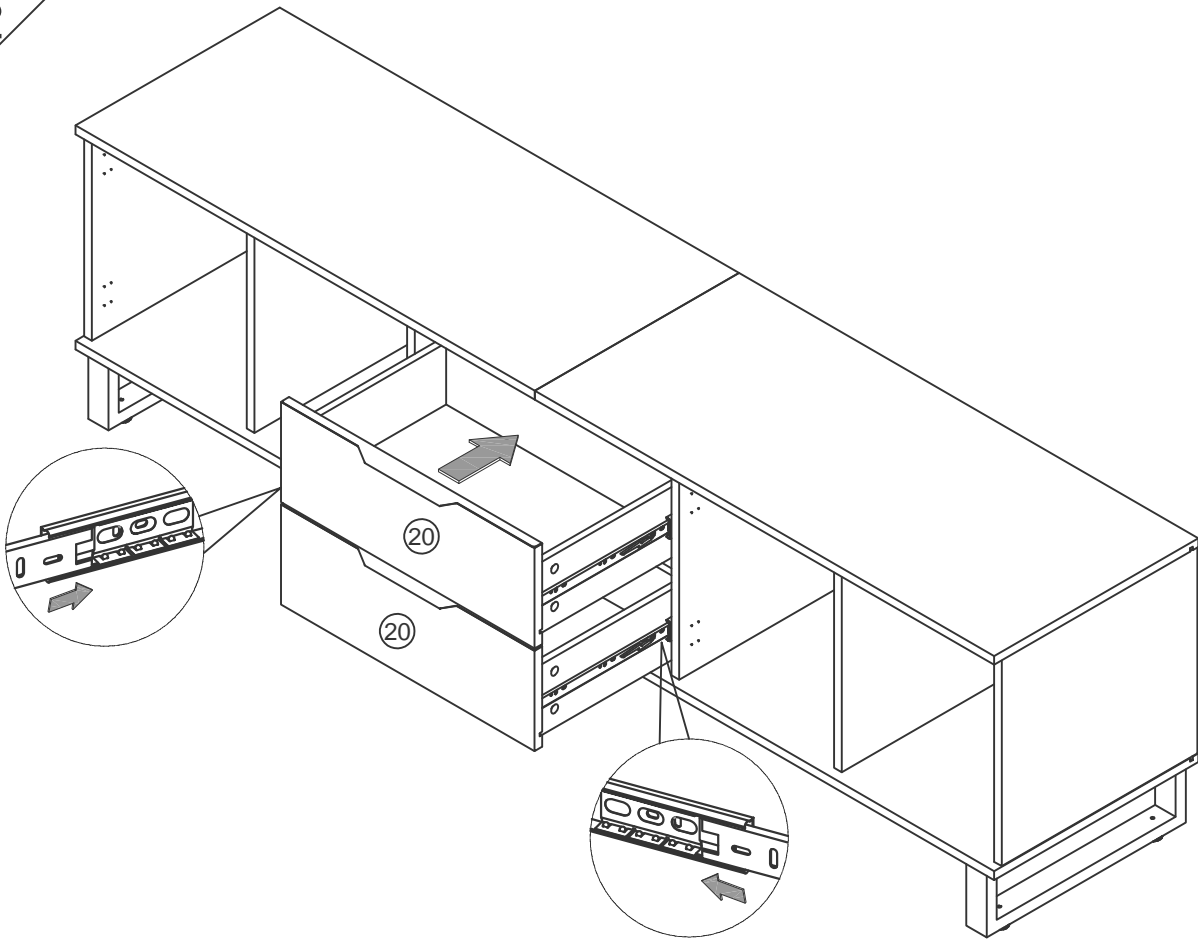

X2

12

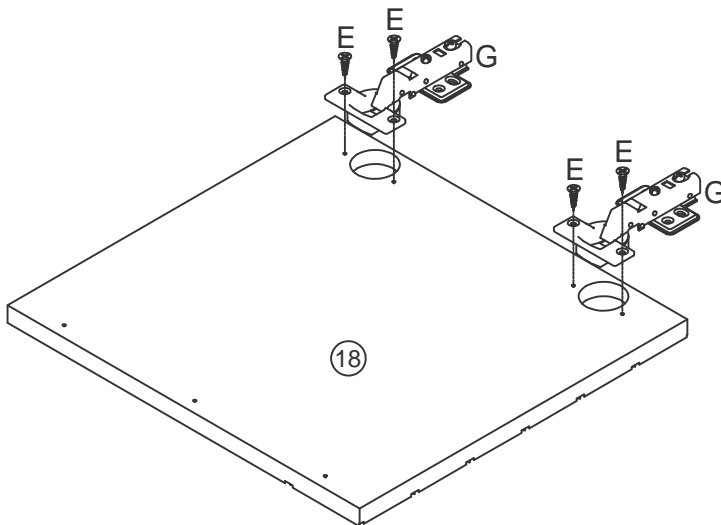

13



Ⓔ M3.5X14	Ⓖ
	
8 PCS	4 PCS

X2

14

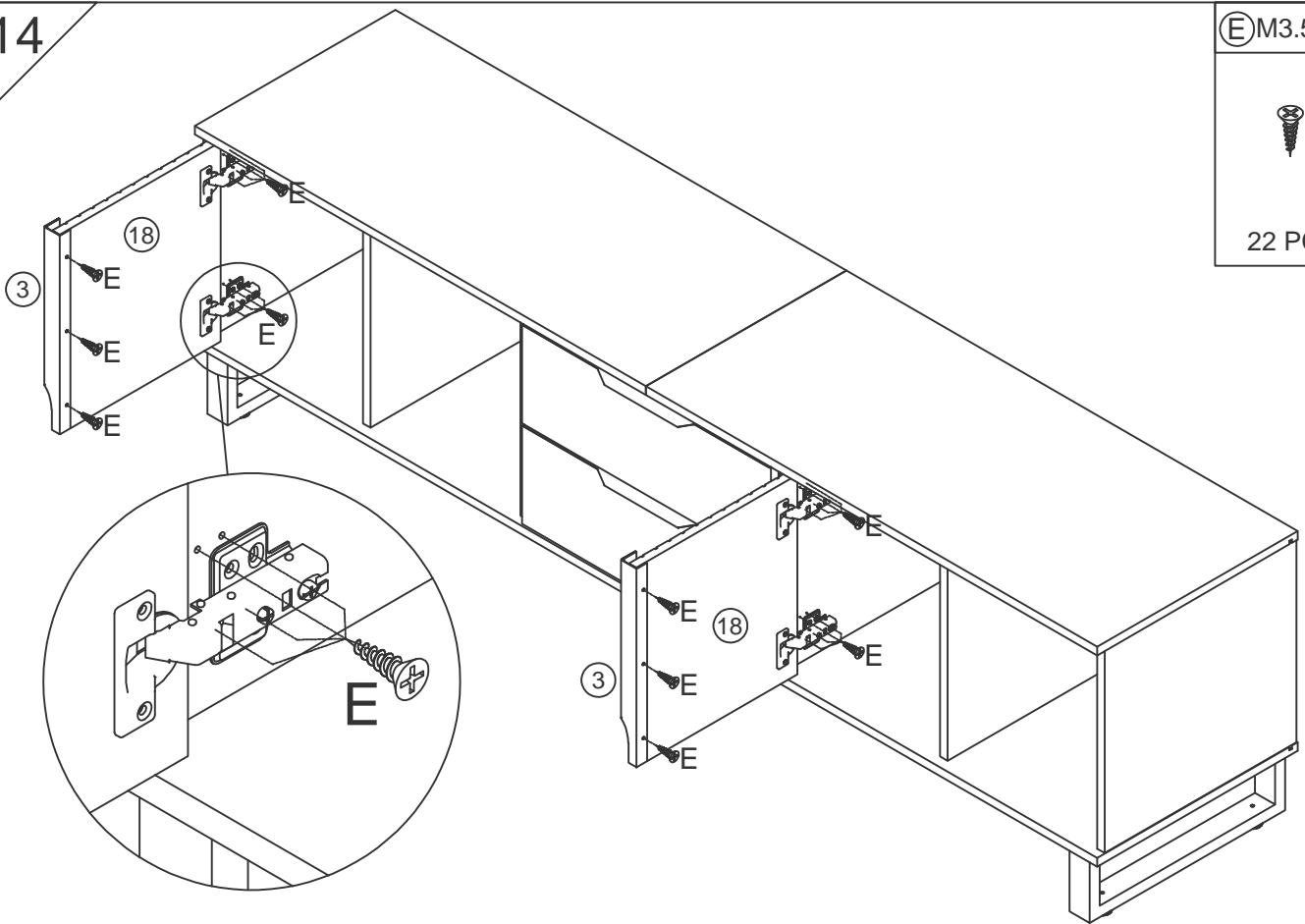

ⓔ M3.5X14



22 PCS

15

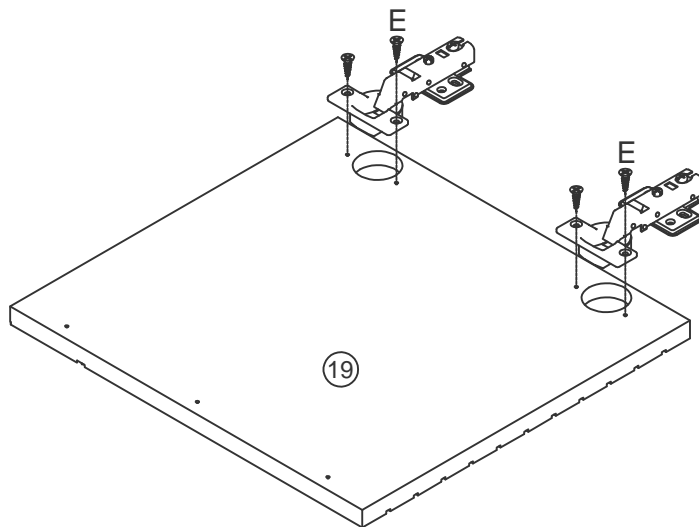

ⓔ M3.5X14

ⓖ



8 PCS



4 PCS

X2

16

ⓔ M3.5X14



22 PCS

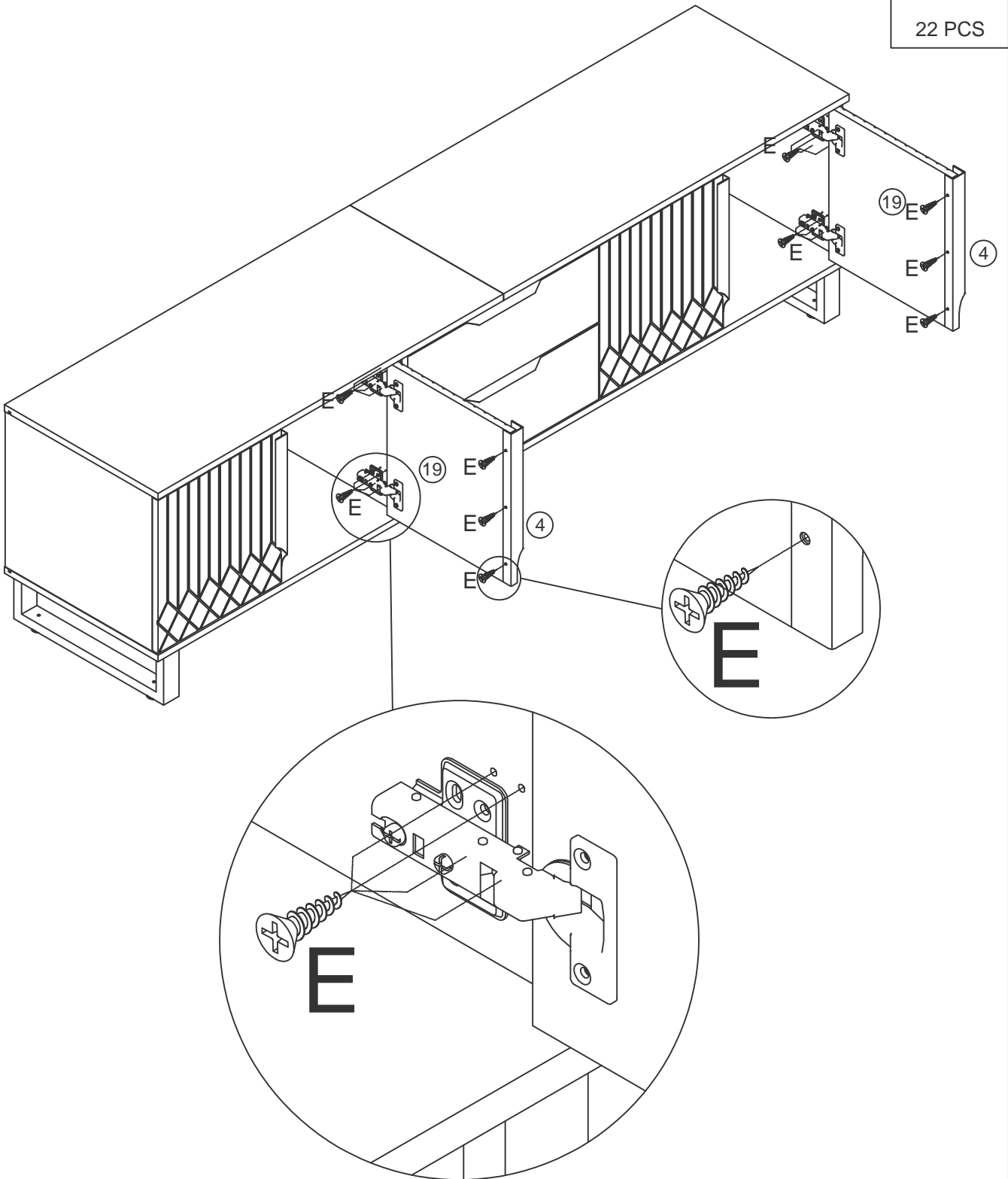



17

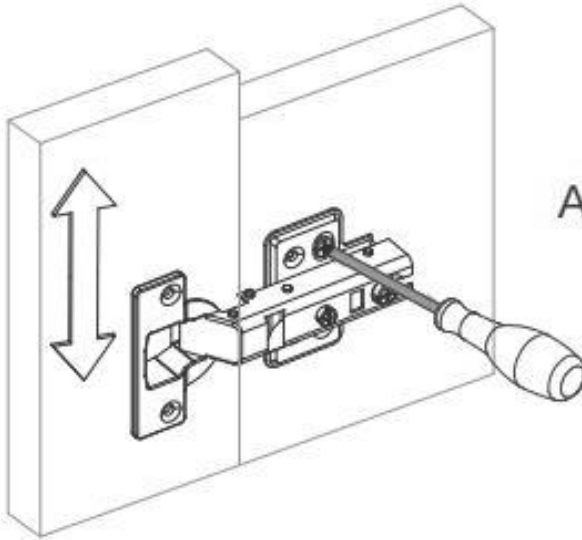

Adjustment up or down

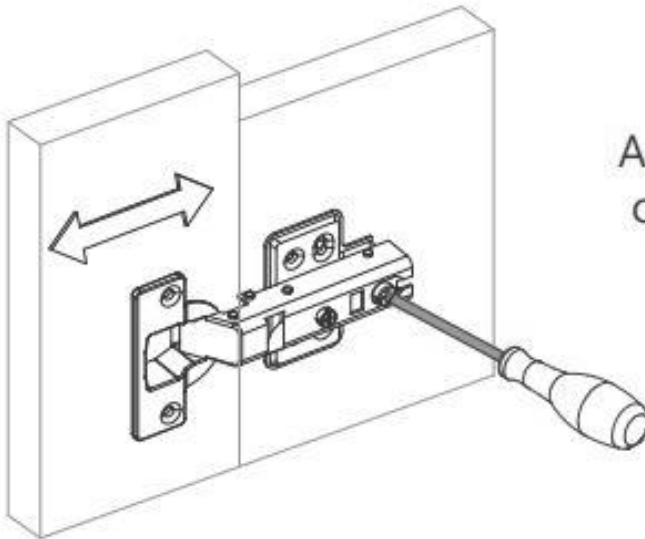

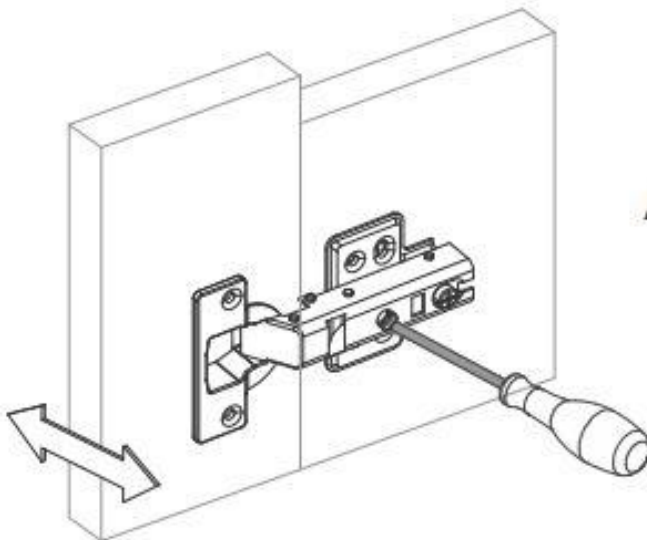

Adjustment forward  
or backward



Adjustment left or right

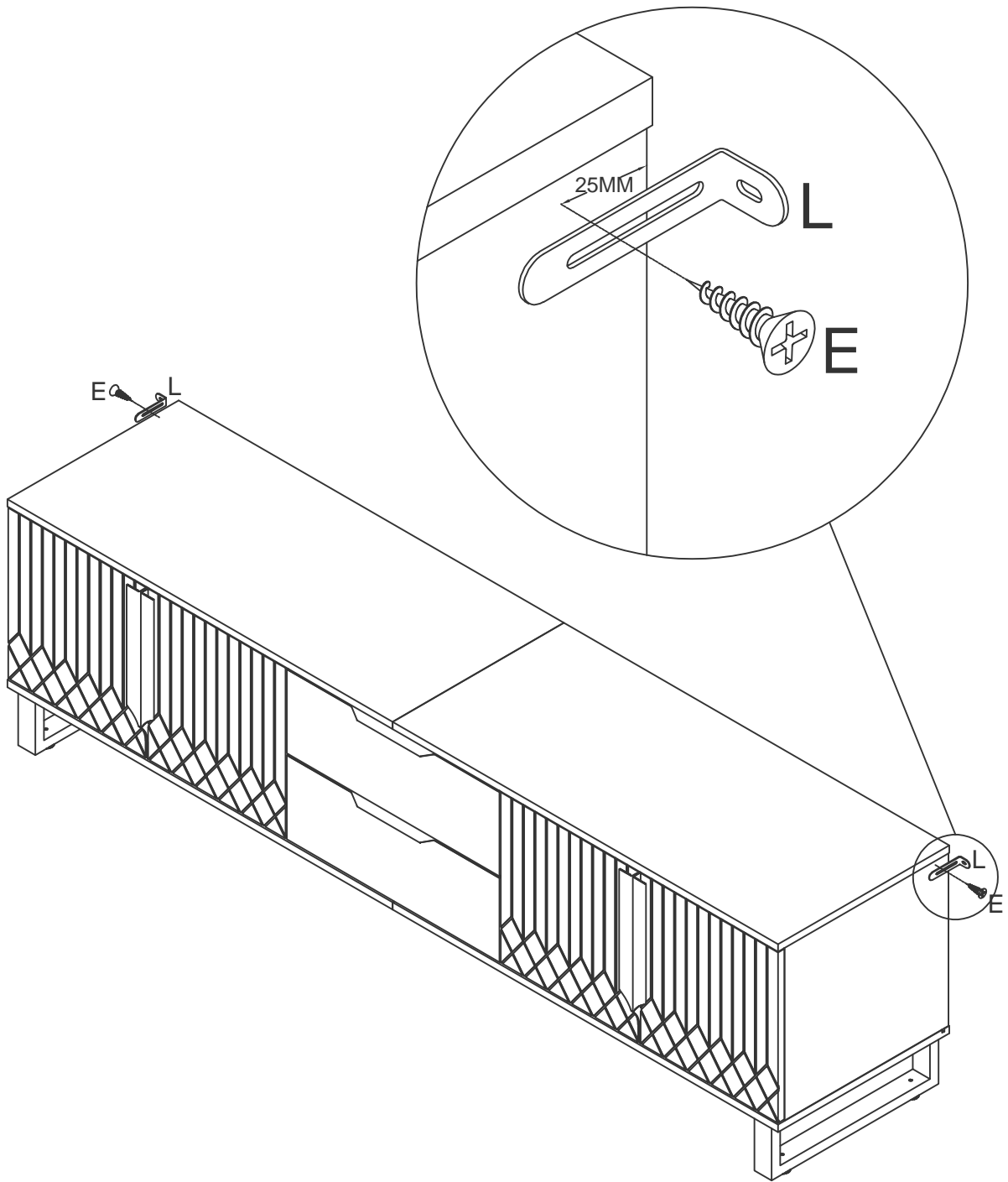

18

(L)	(E) M3.5X14
	
2 PCS	2 PCS



19

 **Attention: For safety and stability, we suggest you have to secure the anti-tip accessories to the wall to prevent tipping, injury, and property damage.**

 2 PCS	 2 PCS
--	--

Step 1

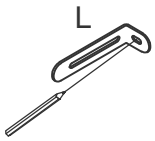

Step 2



Step 3

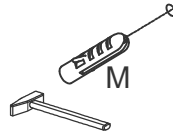

Step 4

