

# ASSEMBLY INSTRUCTIONS

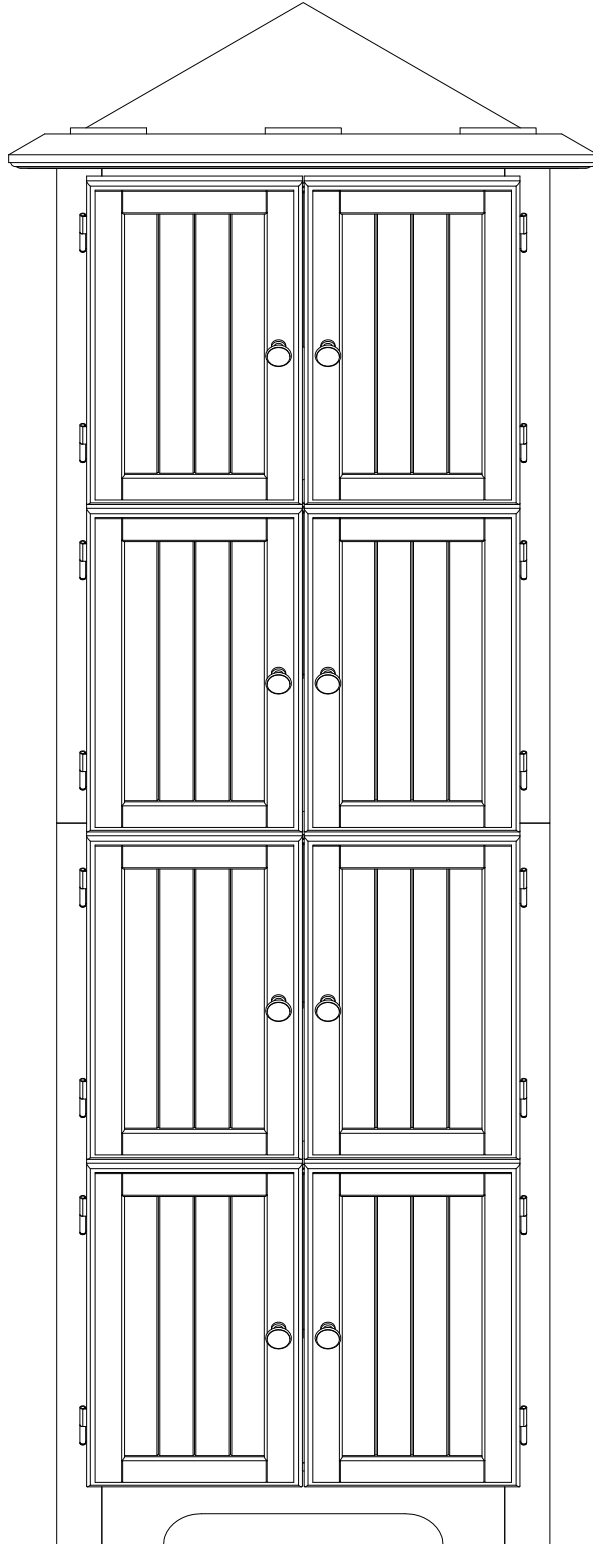

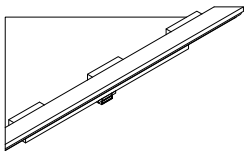

# ASSEMBLY INSTRUCTIONS

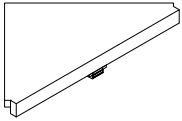
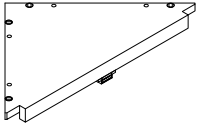
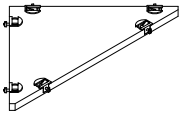
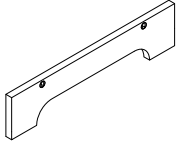
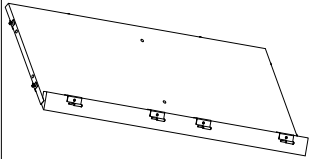
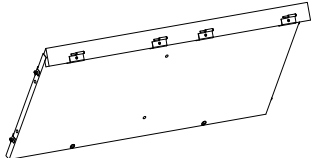

## Part List:

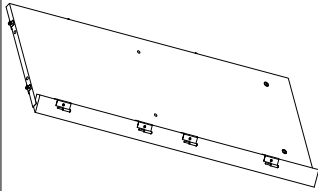
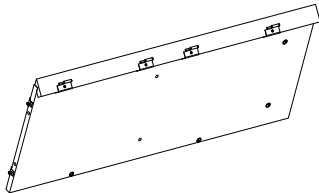
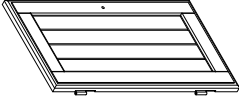
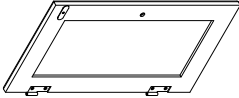
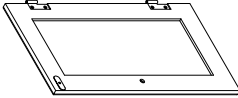
ITEM	DESCRIPTION	PART	QTY
1	Top		1
2	Shelf		2
3	Middle panel		1
4	Bottom		1
5	Apron		1
6	Upper left side		1
7	Upper right side		1

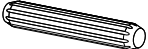

## Part List:

ITEM	DESCRIPTION	PART	QTY
8	Lower left side		1
9	Lower right side		1
10	Upper left door		1
11	Upper right door		1
12	Lower left door		3
13	Lower right door		3

## Hardware List:

ITEM	DESCRIPTION	PART	QTY
A	Short wooden dowel		12
B	Long wooden dowel		4
C	Plastic anchor		1

## Hardware List:

ITEM	DESCRIPTION	PART	QTY
D	Mounting screw		1
E	Flat washer		1
F	Knob		8

Tip: It is recommended to keep all hardware in a box to avoid loss during installation.

- \* Required screwdriver & mallet, not included.
- \* Before discarding packing materials, please check to make sure that all parts and hardware is present.
- \* Two people needed for assembly.
- \* Please follow the instructions closely; do not over tighten screws or bolts unless instructed.
- \* Caution: If using a power drill or power screwdriver for screwing, please be aware to slow down and stop when screw is tight. Failure to do so may result in stripping the screw.

## Guideline For Assembling of Plastic Lock

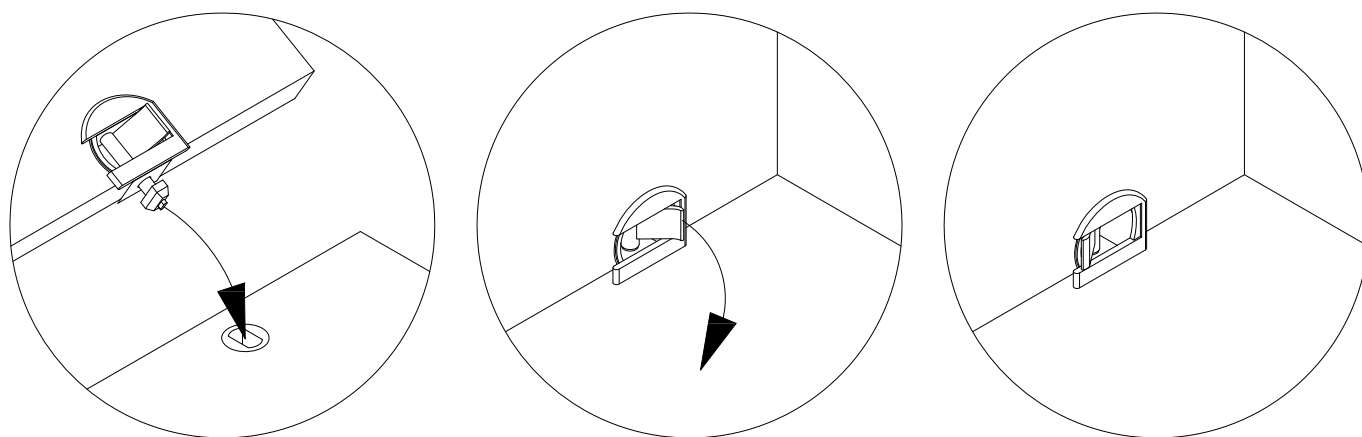

## STEP 1

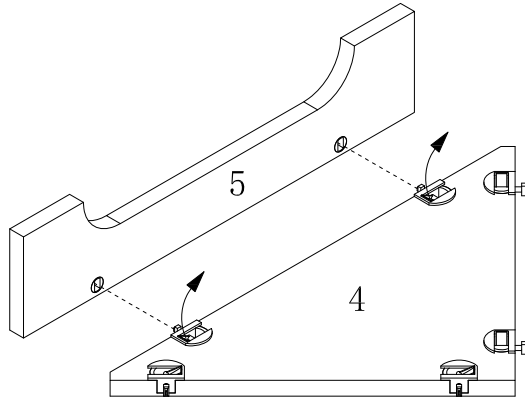

## STEP 2

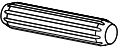
A:  2PCS

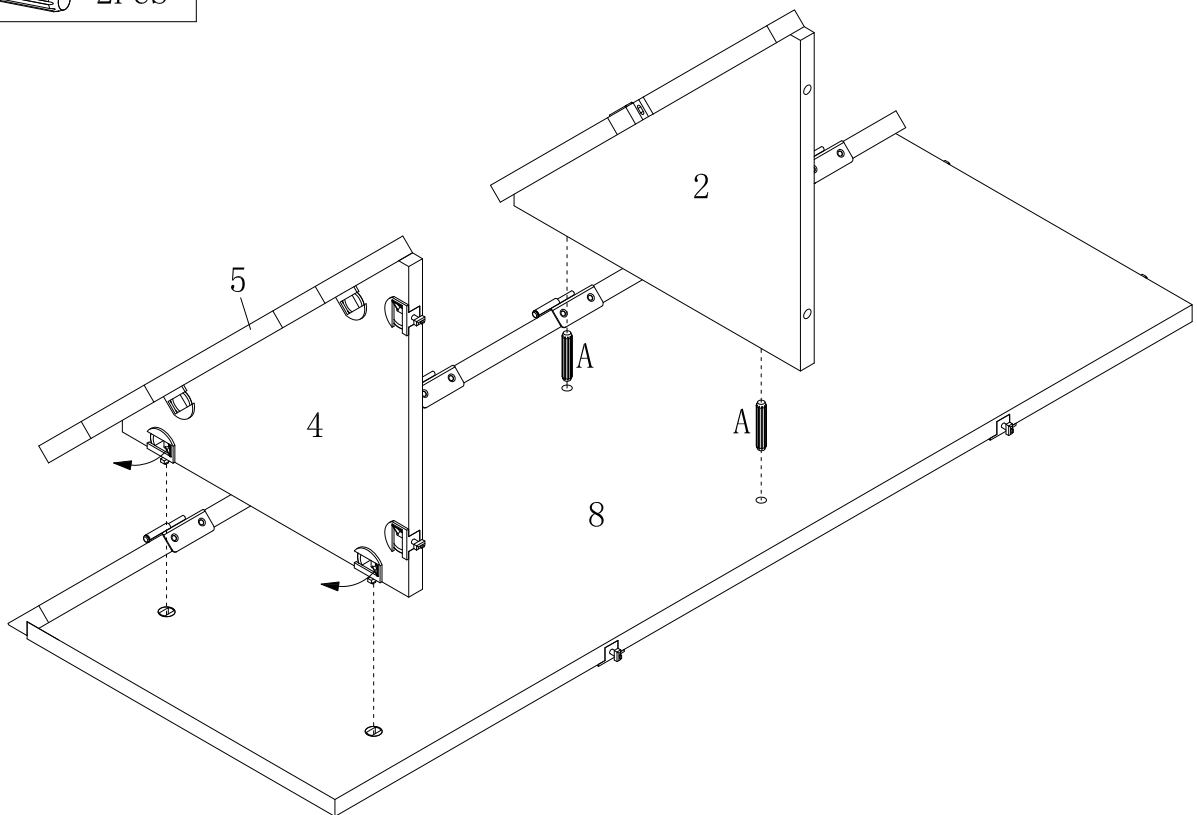

# ASSEMBLY INSTRUCTIONS

## STEP 3

A:  2PCS

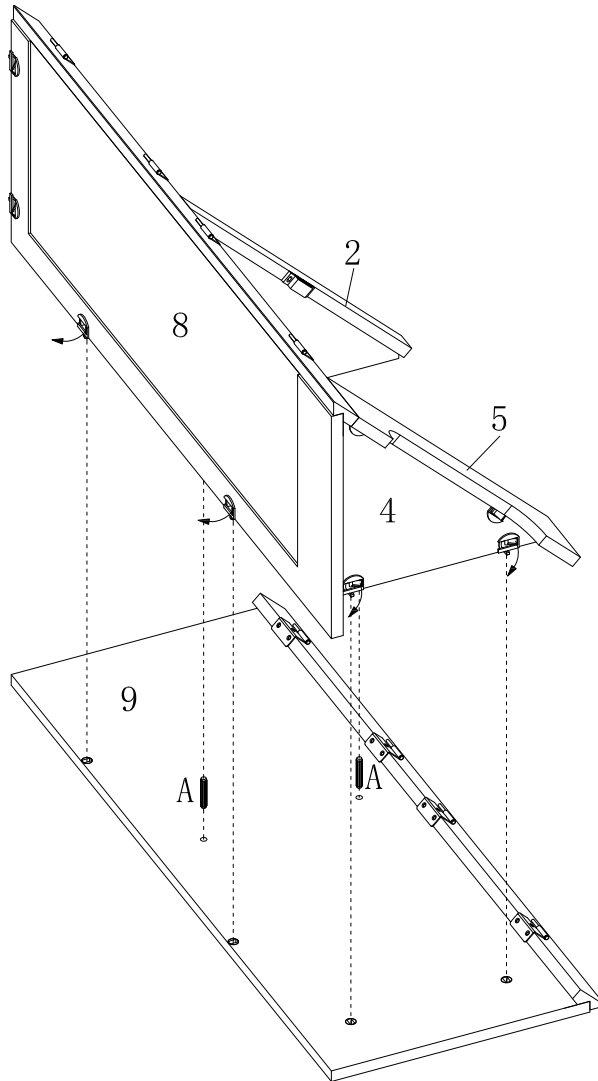

## STEP 4

A:  2PCS

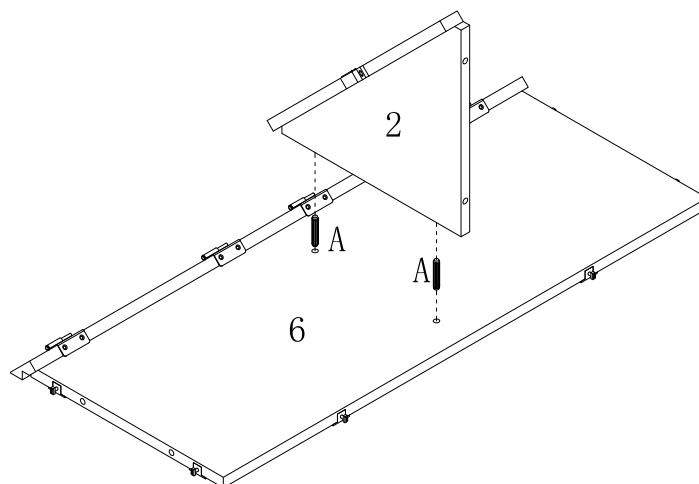

## STEP 5

A:  2PCS

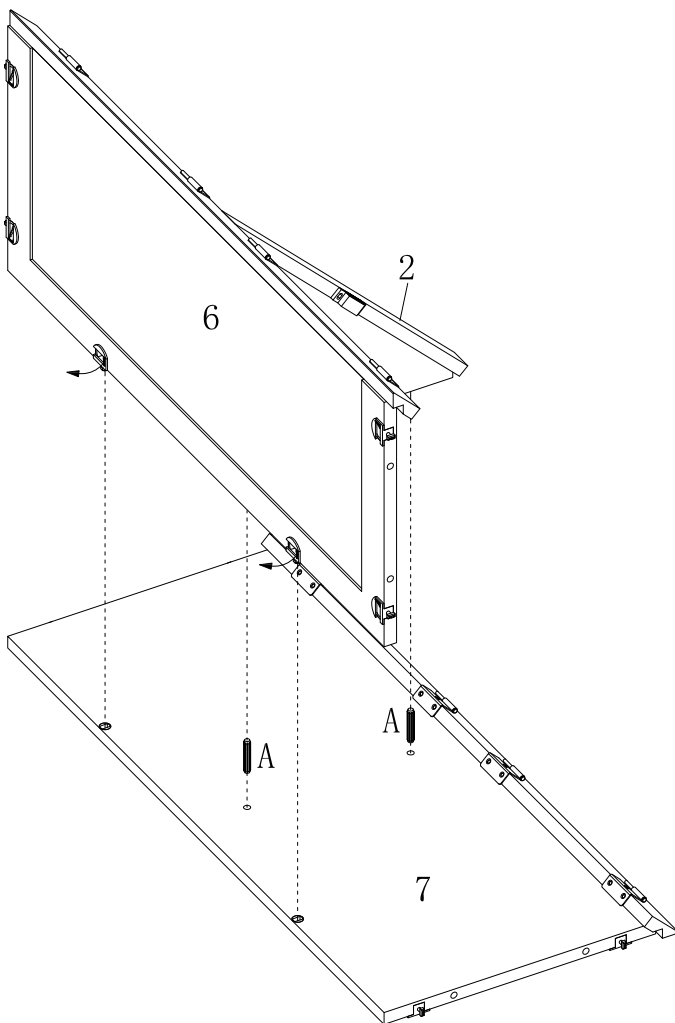

## STEP 6

B:  4PCS

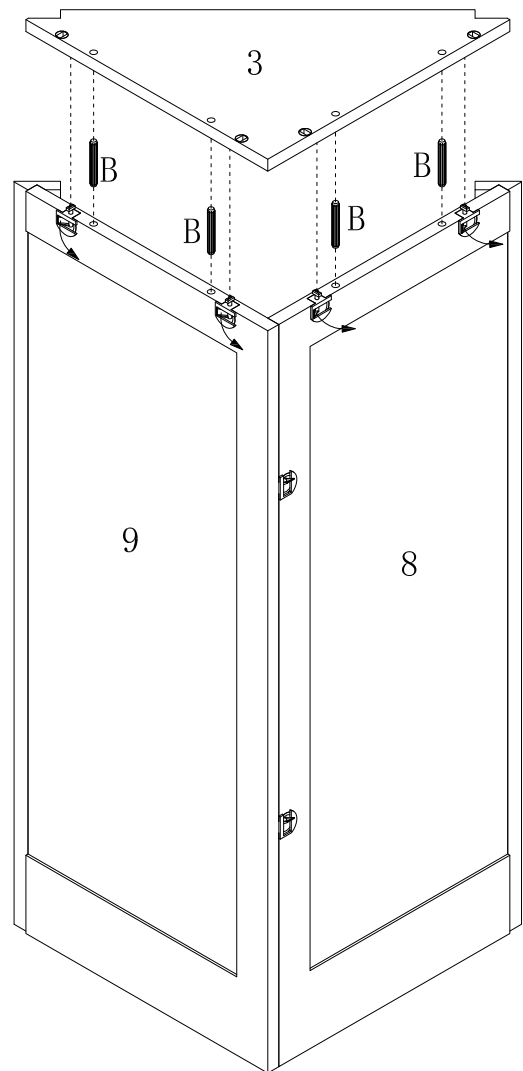

## STEP 7

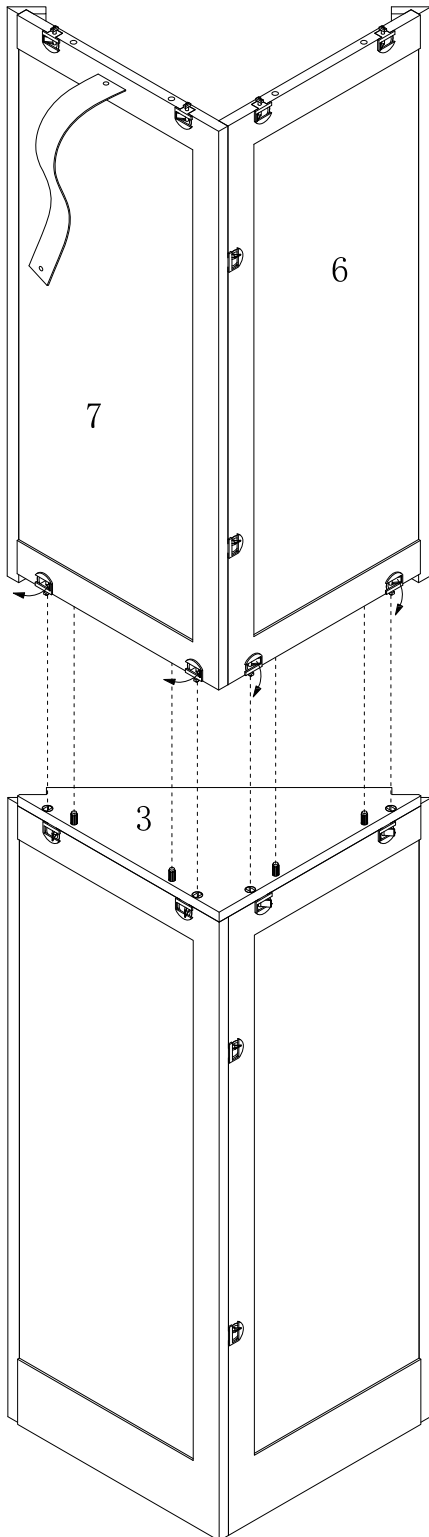

## STEP 8

A:  4PCS

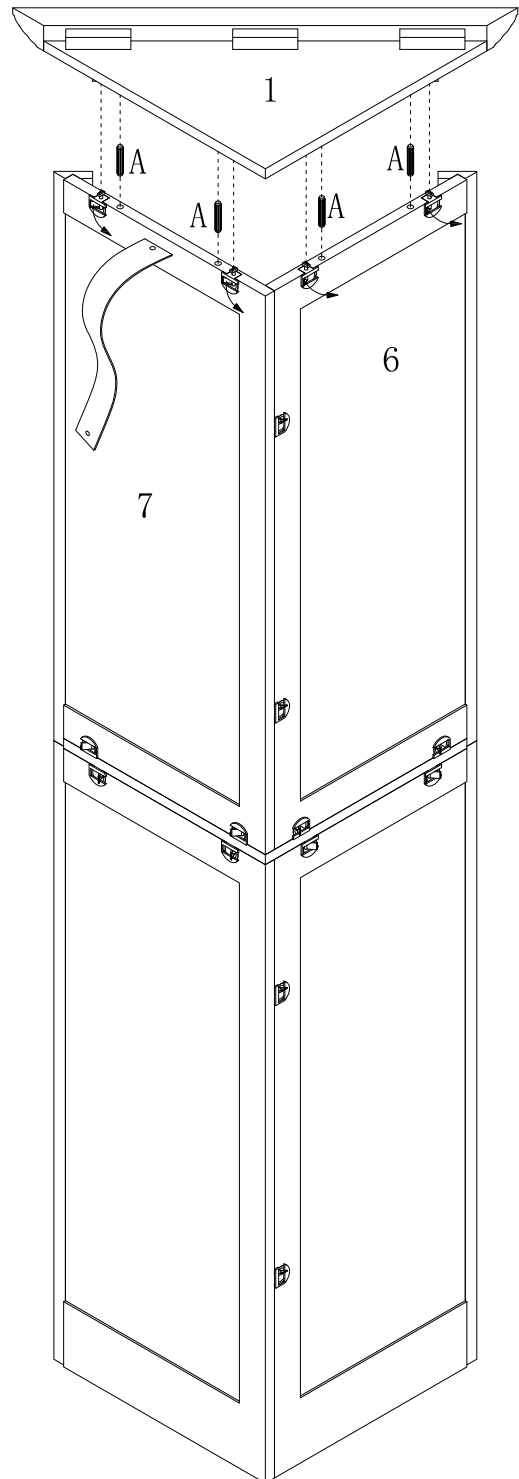





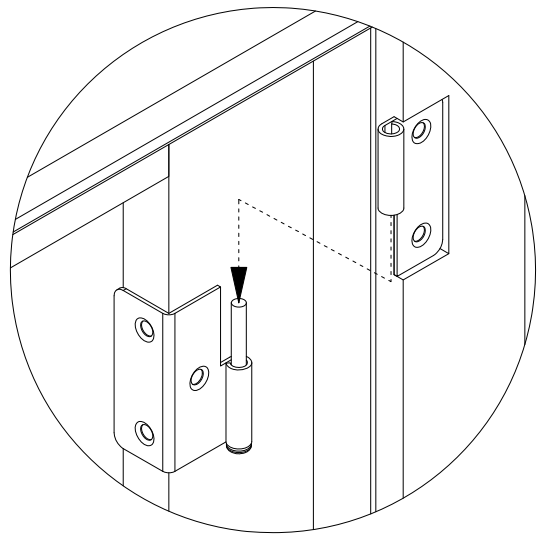
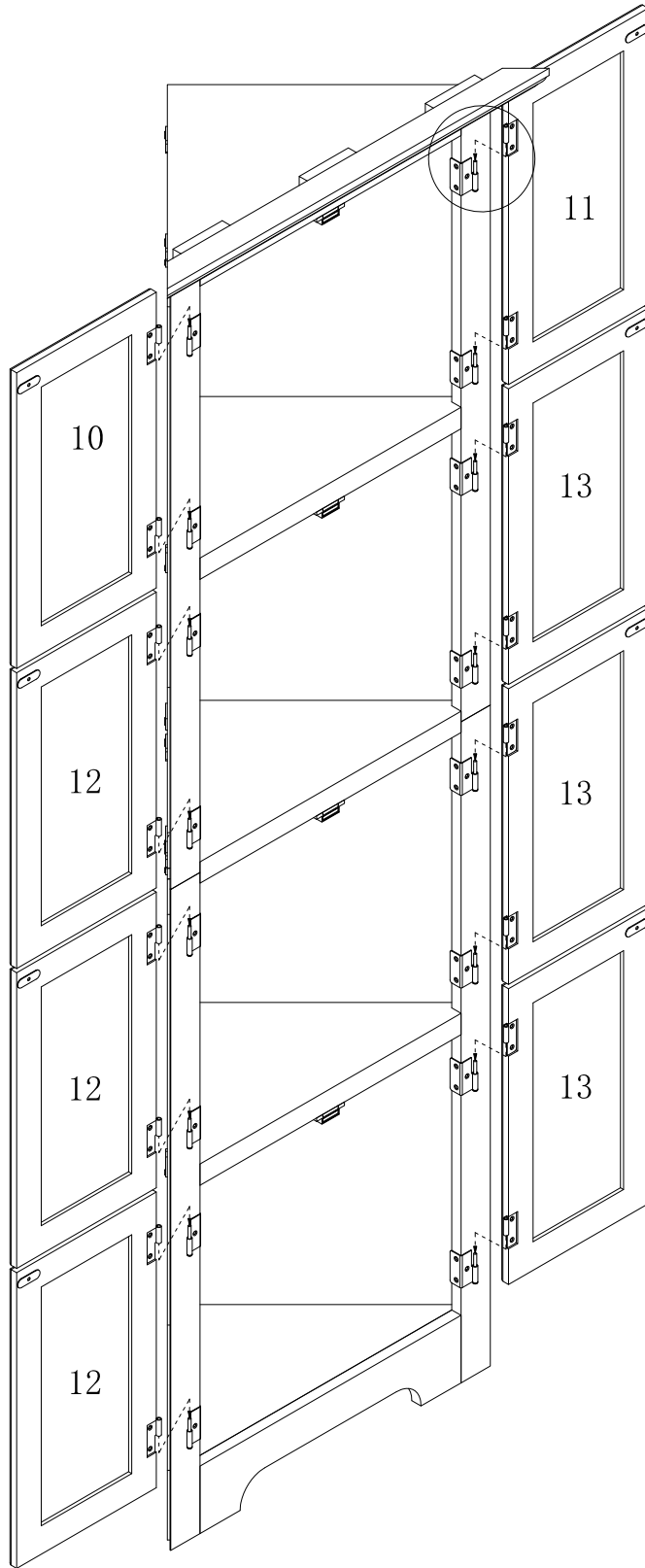

STEP 9



# ASSEMBLY INSTRUCTIONS

## STEP 10

C:		1PC
D:		1PC
E:		1PC
F:		8PCS

