

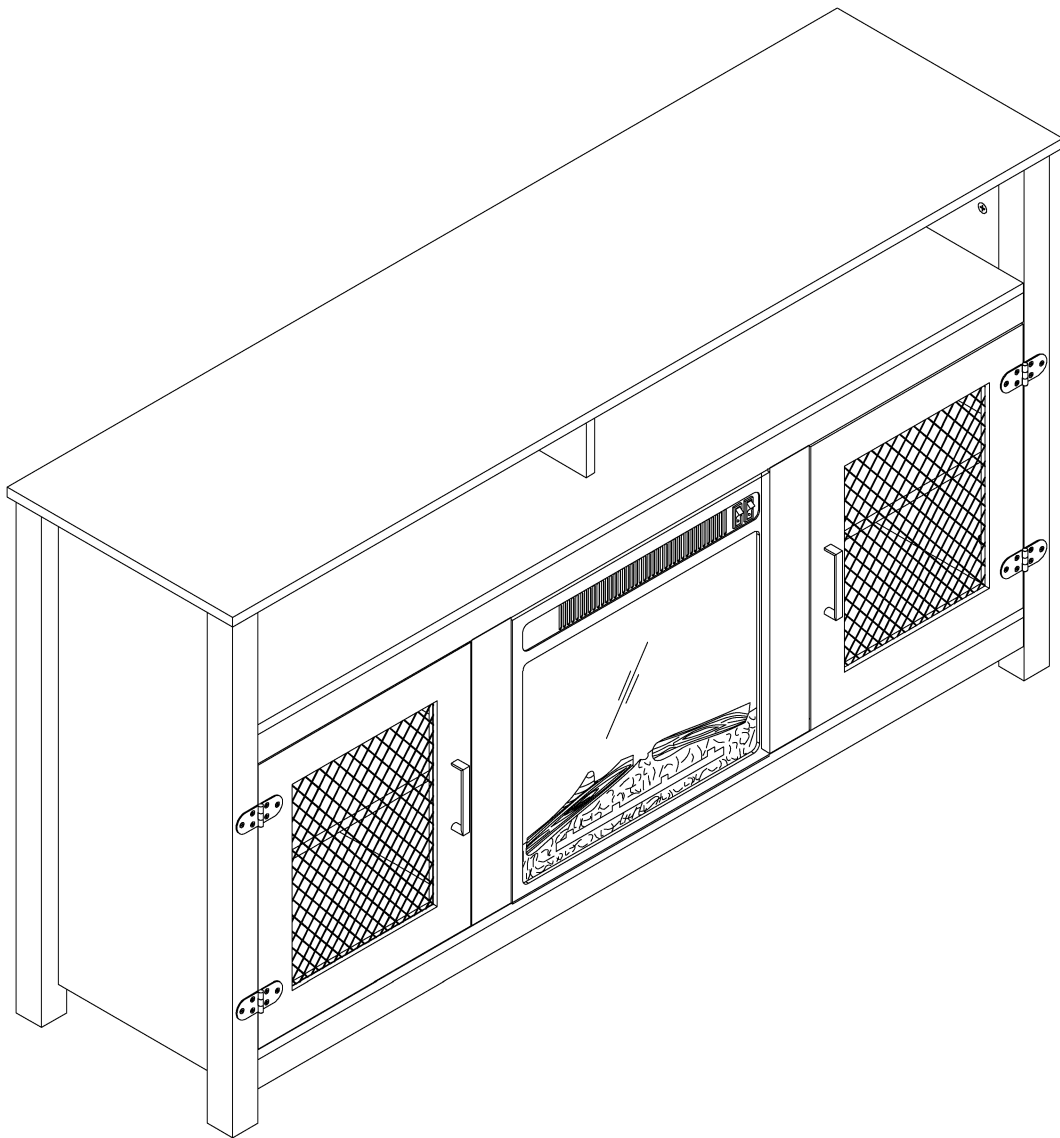

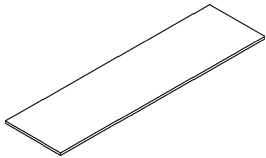

ASSEMBLY INSTRUCTIONS



ASSEMBLY INSTRUCTIONS

Part List:

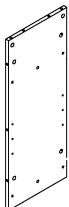
ITEM	DESCRIPTION	PART	QTY
1	Top Panel		1
2	Left Front Post		1
3	Left side Panel		1
4	Left Back Post		1
5	Right Front Post		1
6	Right side Panel		1

Part List:

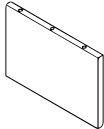
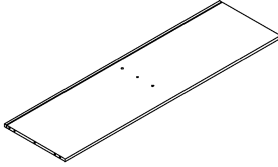
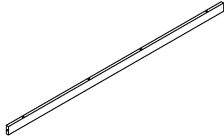
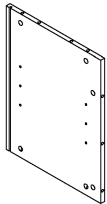
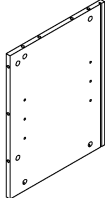
ITEM	DESCRIPTION	PART	QTY
7	Right Back Post		1
8	Upper Divider		1
9	Middle Panel		1
10	Cross Piece		2
11	Lower Left Divider		1
12	Lower Right Divider		1

ASSEMBLY INSTRUCTIONS

Part List:

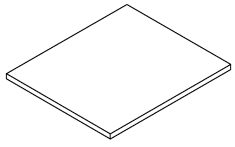
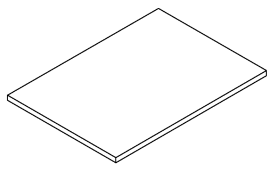
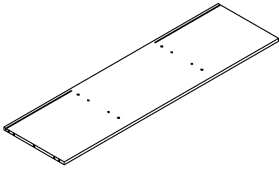
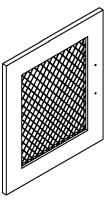
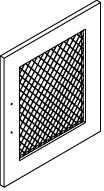



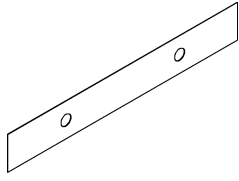
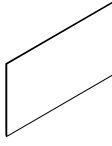
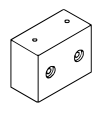

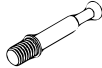

ITEM	DESCRIPTION	PART	QTY
13	Vertical Bar		2
14	Side Adjustable shelf		2
15	middle Adjustable shelf		1
16	Bottom panel		1
17	Left Door		1
18	Right Door		1

Part List:









ITEM	DESCRIPTION	PART	QTY
19	Middle Leg		1
20	Upper Back Panel		1
21	Lower Back Panel		4
22	Magnetic fixing Panel		2

ASSEMBLY INSTRUCTIONS



Hardware List:



ITEM	DESCRIPTION	PART	QTY
A	Camlock bolt		46
B	Camlock		46
C	Wooden dowel	 Ø8x40mm	30
D	Door handle		2
E	Machine screw	 Ø5/32" x7/8"	4
F	Hinge		4
G	Wood screw	 Ø3x12mm	36
H	Wood screw	 Ø4x30mm	4
I	Magnetic		2

Hardware List:

ITEM	DESCRIPTION	PART	QTY
J	Flat Head screw	 Ø3x15mm	4
K	Shelf Support		12
L	Plastic Anchor		1
M	Washer		1
N	Back Insert Buckle		12
O	Safety Wall Strap		1
P	Wood screw	 Ø4x45mm	6
Q	Mounting screw	 Ø4x38mm	1

Belows are fireplace' s parts list:

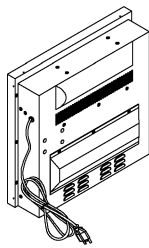
DESCRIPTION	PART	QTY
Side trim		2
Top trim		1

DESCRIPTION	PART	QTY
Insert		1
Screw	 Ø5*10mm	14

ASSEMBLY INSTRUCTIONS

Wooden dowel installation

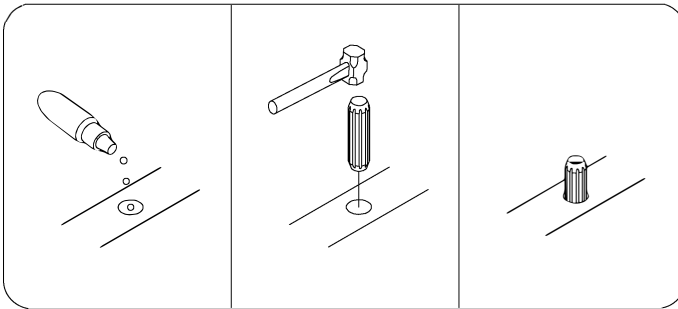

APPLY GLUE INTO PRE-DRILLED HOLE,
AND GENTLY TAP WOOD DOWEL INTO
THE HOLE WITH RUBBER Mallet.

* GLUE--DO NOT PUT IN MOUTH

- * Required screwdriver & mallet, not included.
- * Before discarding packing materials, please check to make sure that all parts and hardware is present.
- * Two people needed for assembly.
- * Please follow the instructions closely; do not over tighten screws or bolts unless instructed.
- * After a few days from initial assembly, the product may have acclimated to the new environment. Please retighten the hardware.

Guideline For Assembling of Cam Lock(A & B)

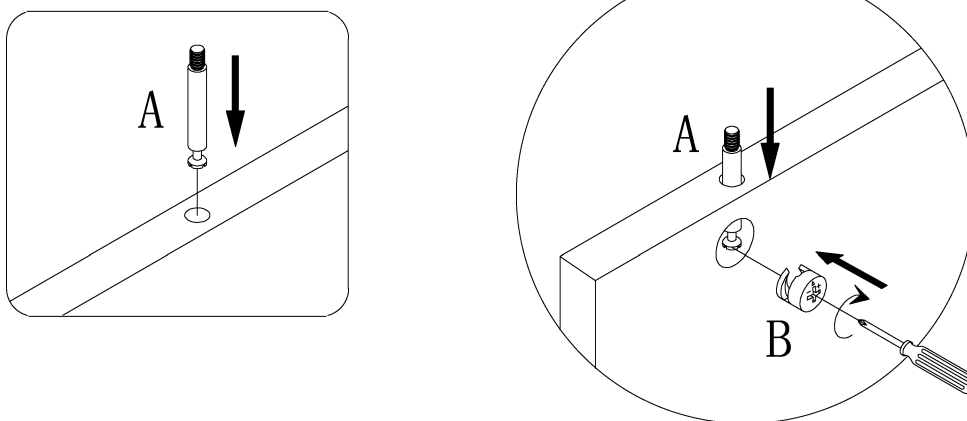



Screw camlock bolt (A) to wood part.

Do not assemble camlock (B) unless instructed.

To assemble camlock (B), ensure long side of the + is facing the bolt (A) before inserting into hole.

ASSEMBLY INSTRUCTIONS

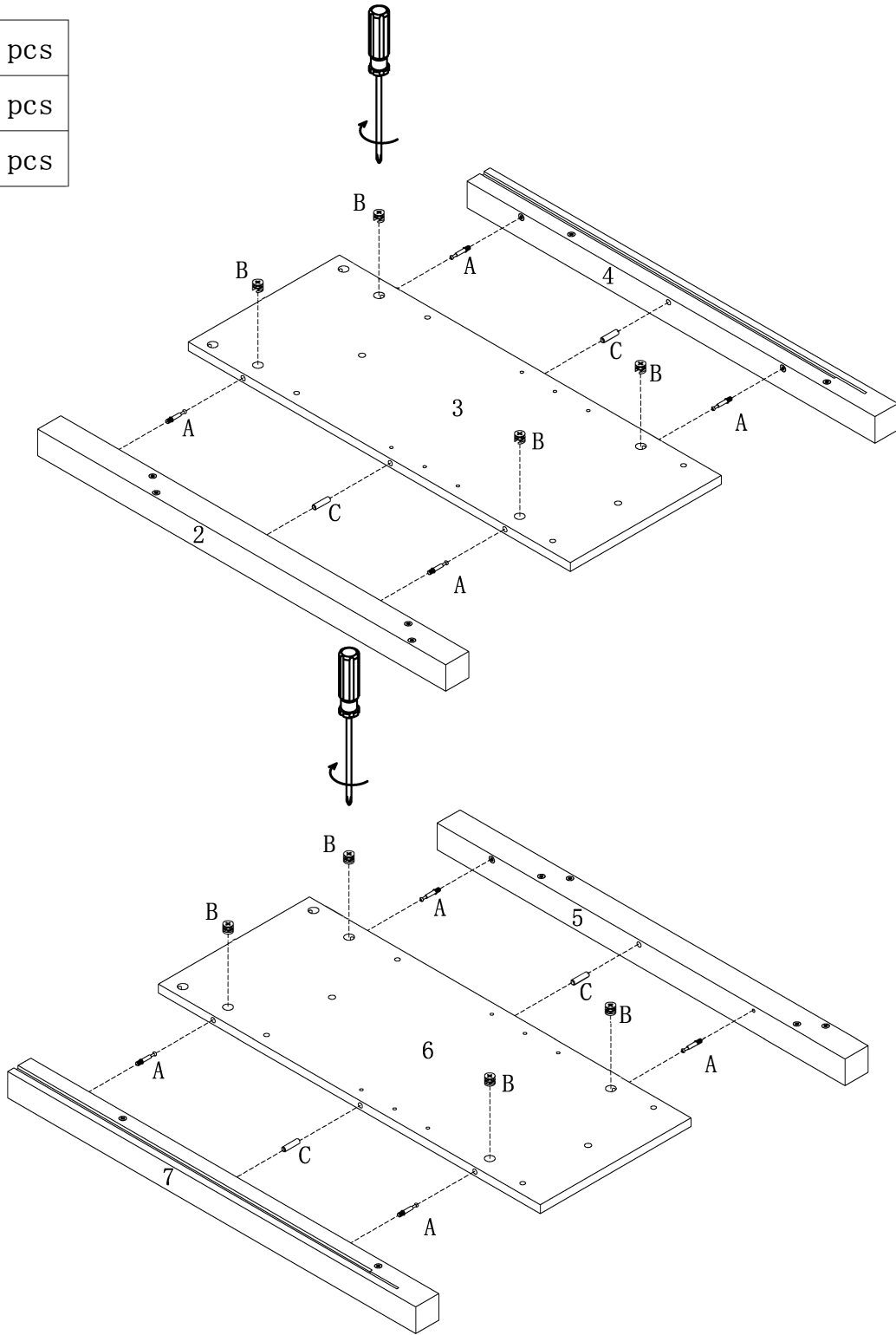

STEP: 1

A:		8 pcs
B:		8 pcs
C:		4 pcs





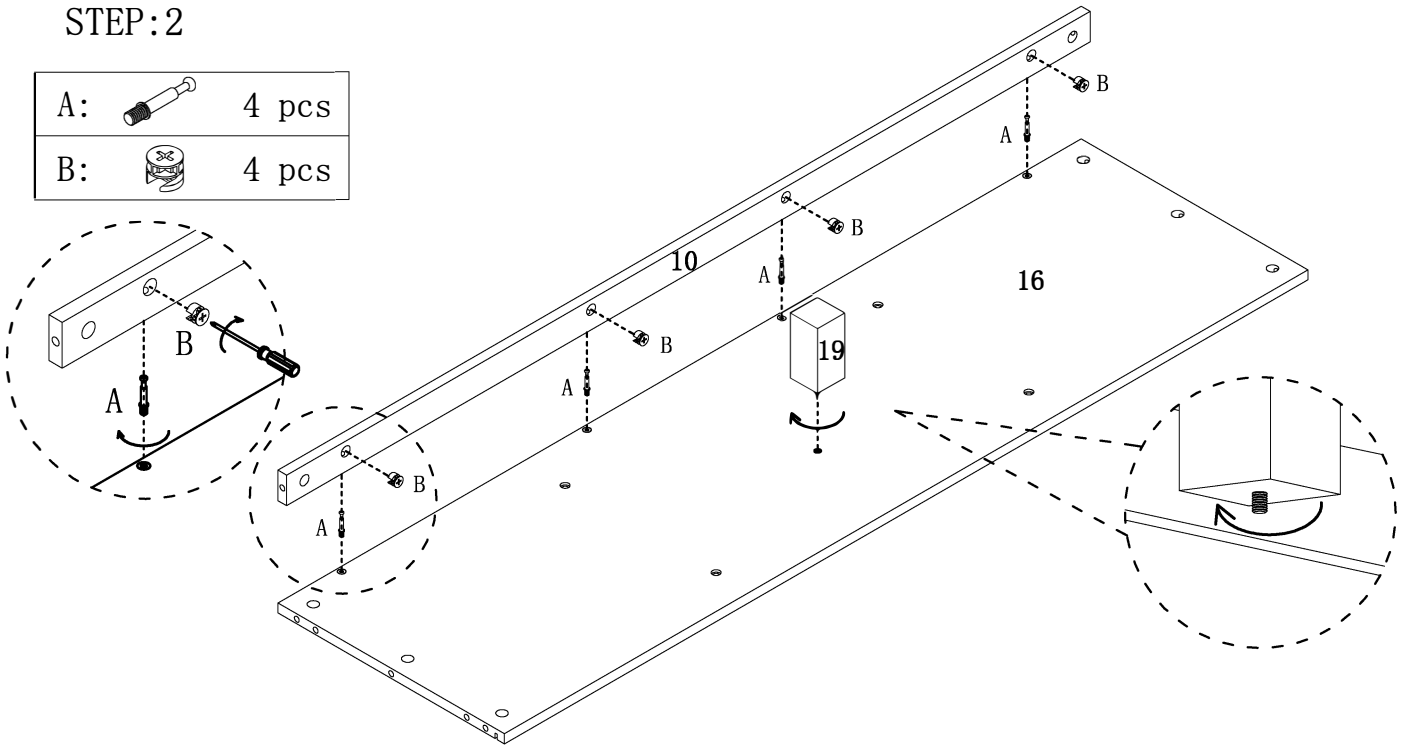

ASSEMBLY INSTRUCTIONS

STEP:2

- | | | |
|----|---|-------|
| A: |  | 4 pcs |
| B: |  | 4 pcs |



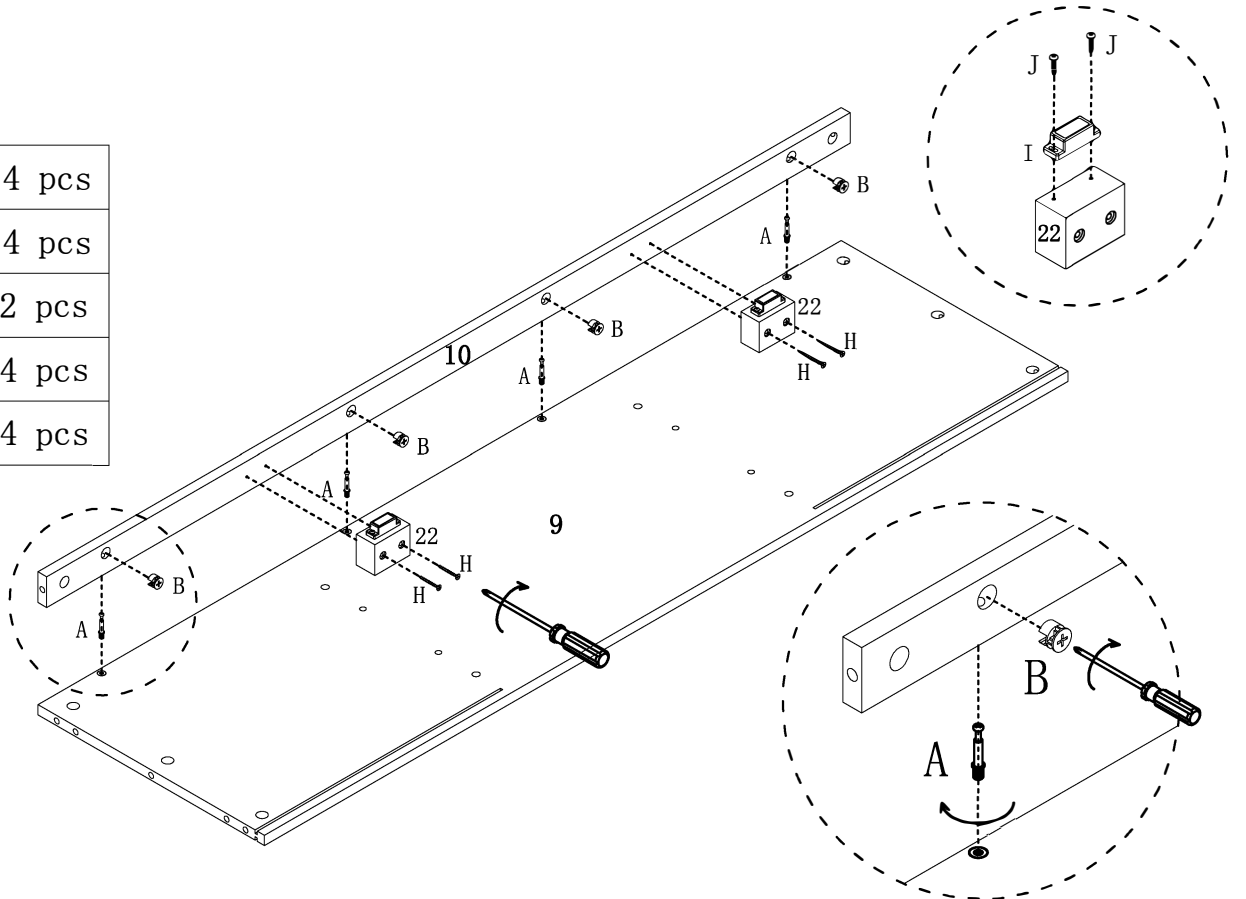

STEP:3

- | | | |
|----|---|-------|
| A: |  | 4 pcs |
| B: |  | 4 pcs |
| I: |  | 2 pcs |
| J: |  | 4 pcs |
| H: |  | 4 pcs |





ASSEMBLY INSTRUCTIONS

STEP:4

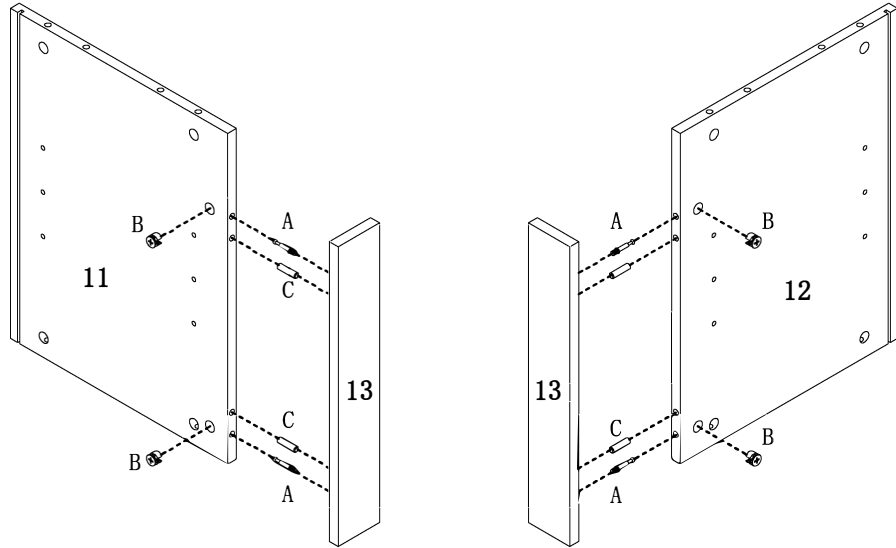
A:		4 pcs
B:		4 pcs
C:		4 pcs



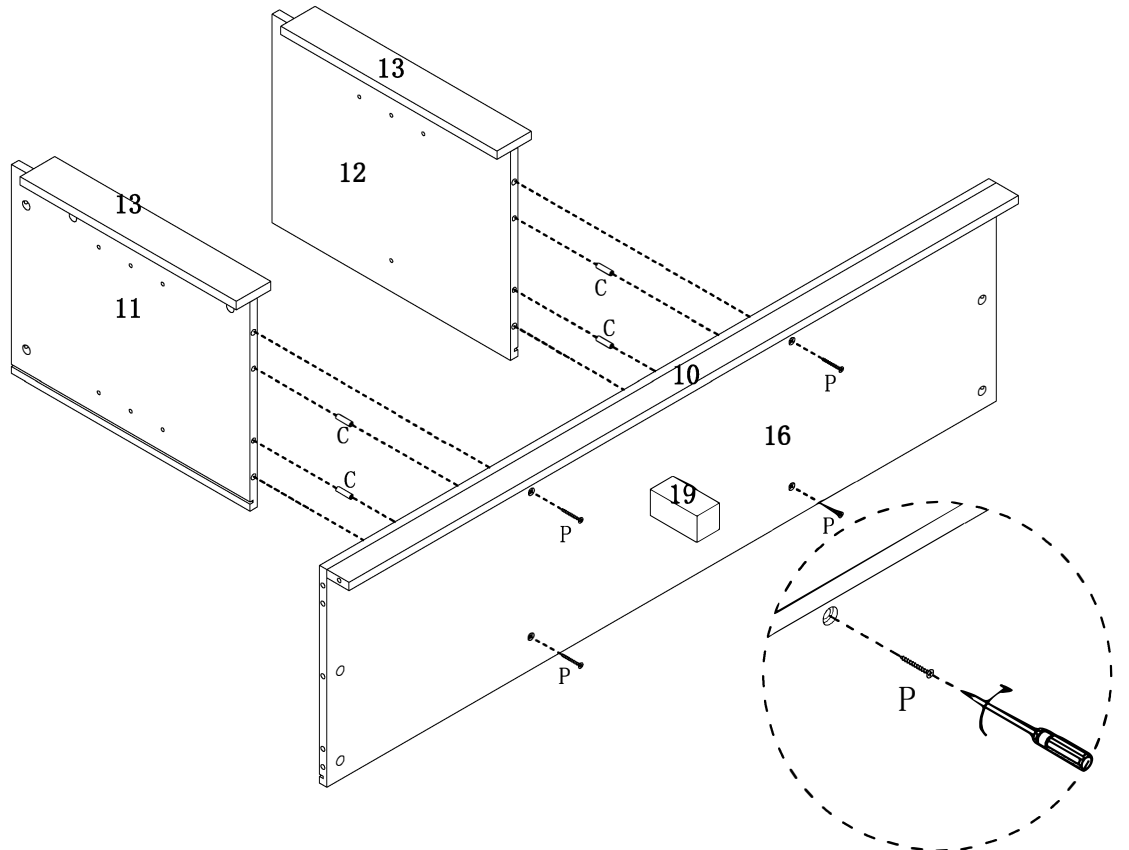

STEP:5

C:		4 pcs
P:		4 pcs



ASSEMBLY INSTRUCTIONS

STEP:6

A:		4 pcs
B:		4 pcs
C:		4 pcs

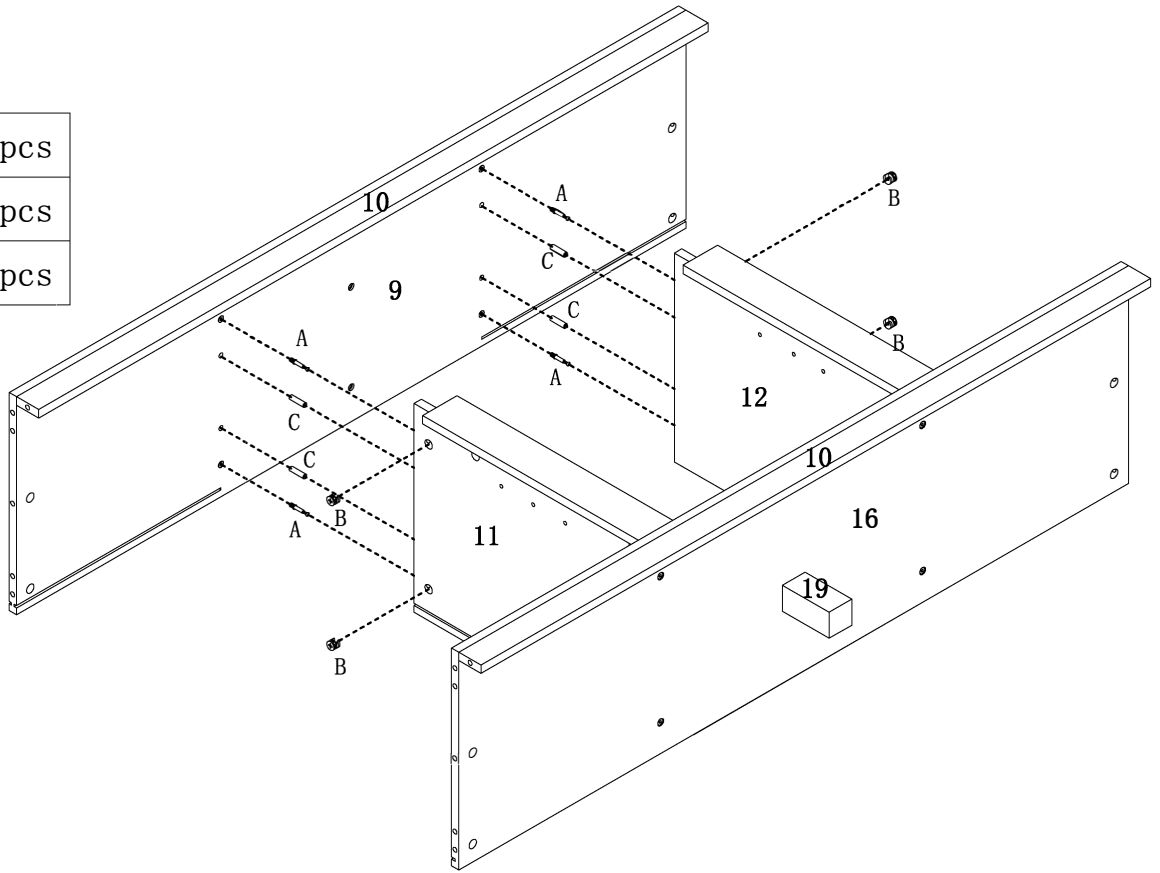

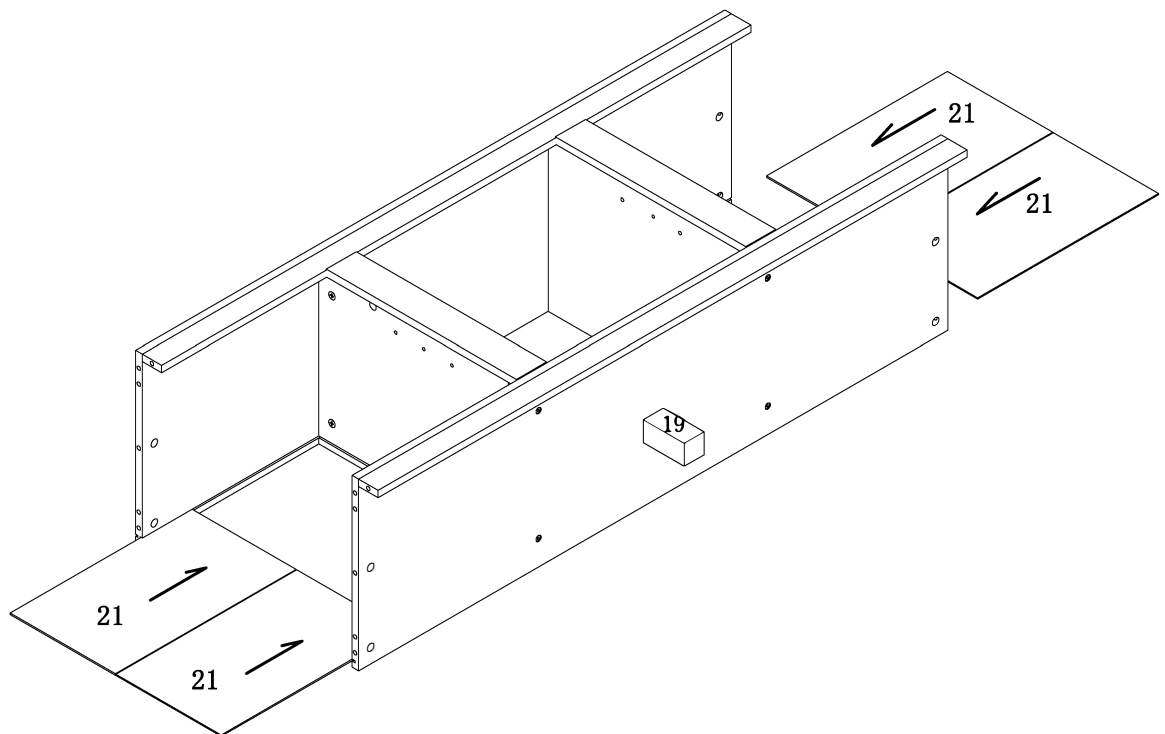

STEP:7



ASSEMBLY INSTRUCTIONS

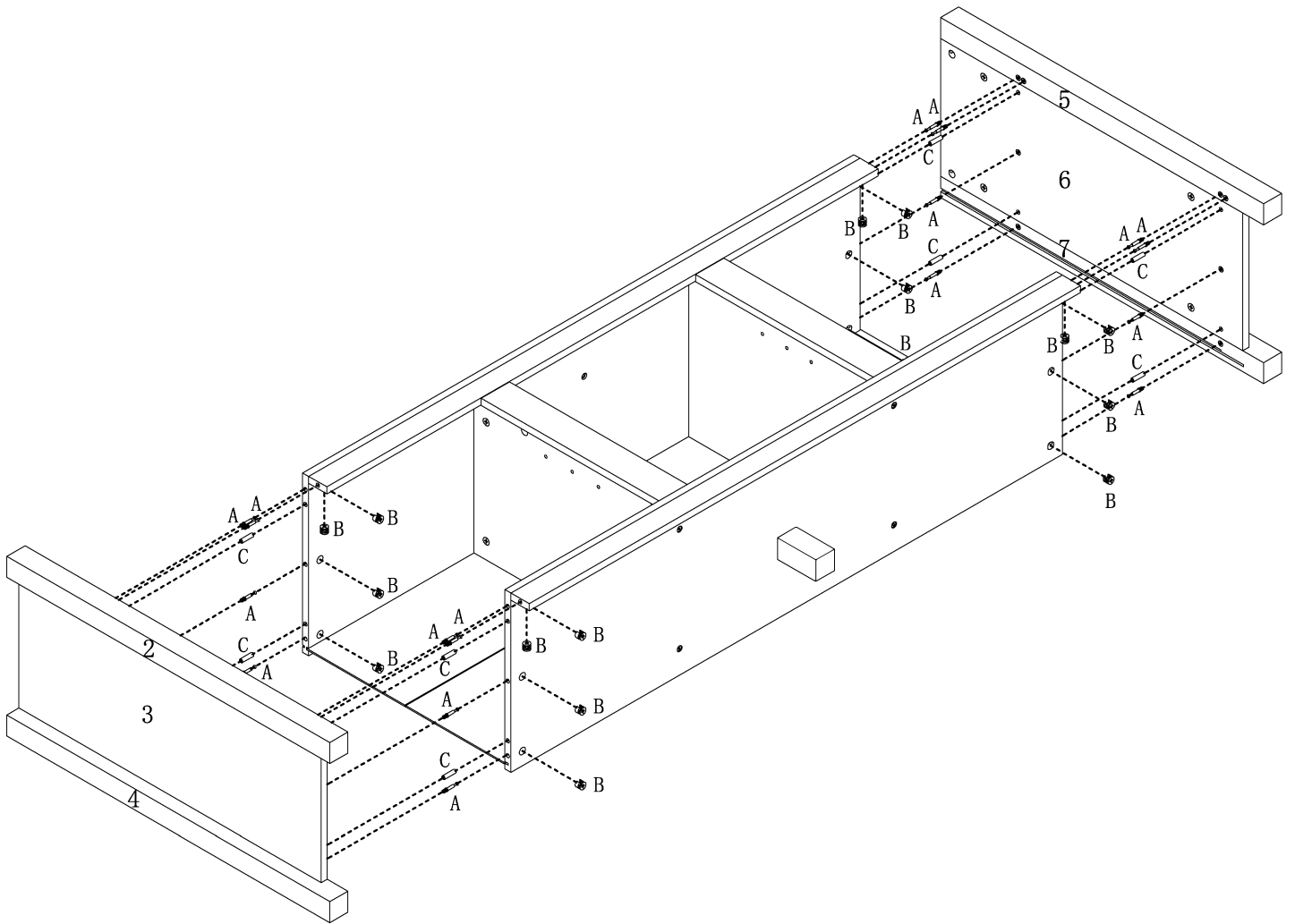

STEP:8

A:		16 pcs
B:		16 pcs
C:		8 pcs



ASSEMBLY INSTRUCTIONS

STEP:9

C:		1 pcs
P:		2 pcs

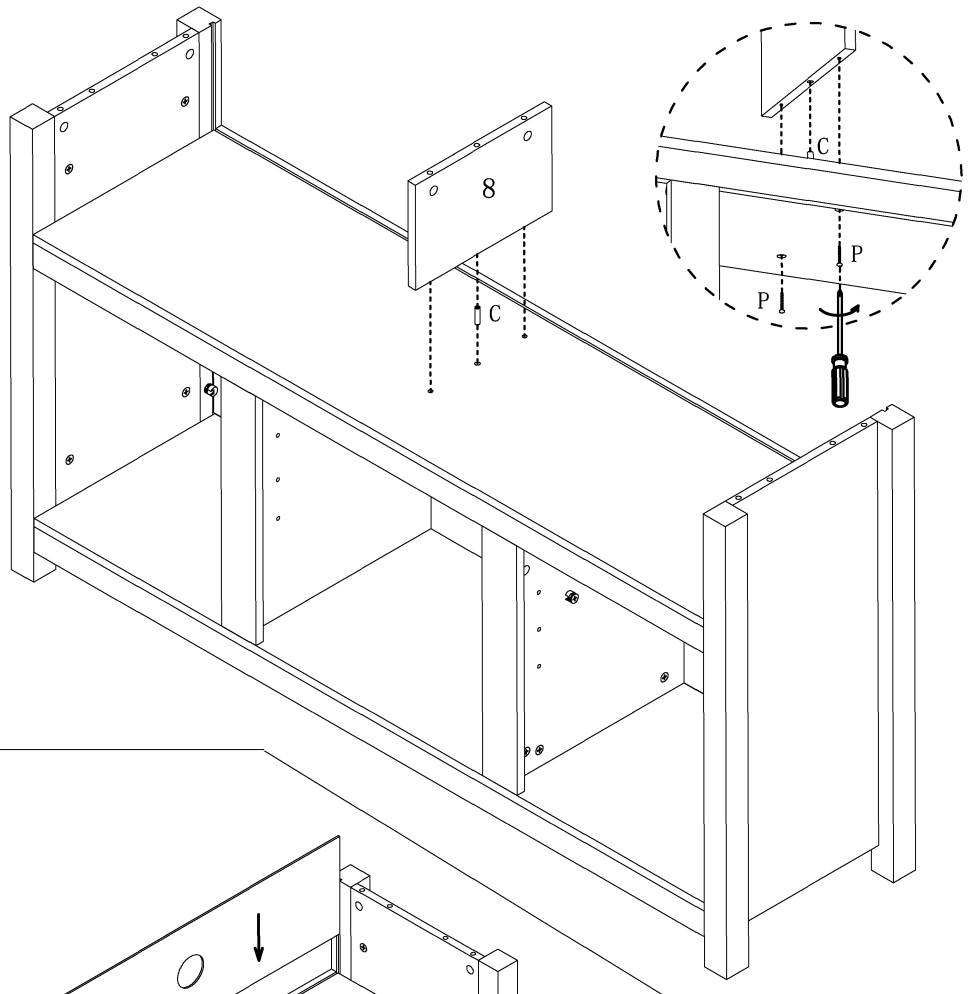

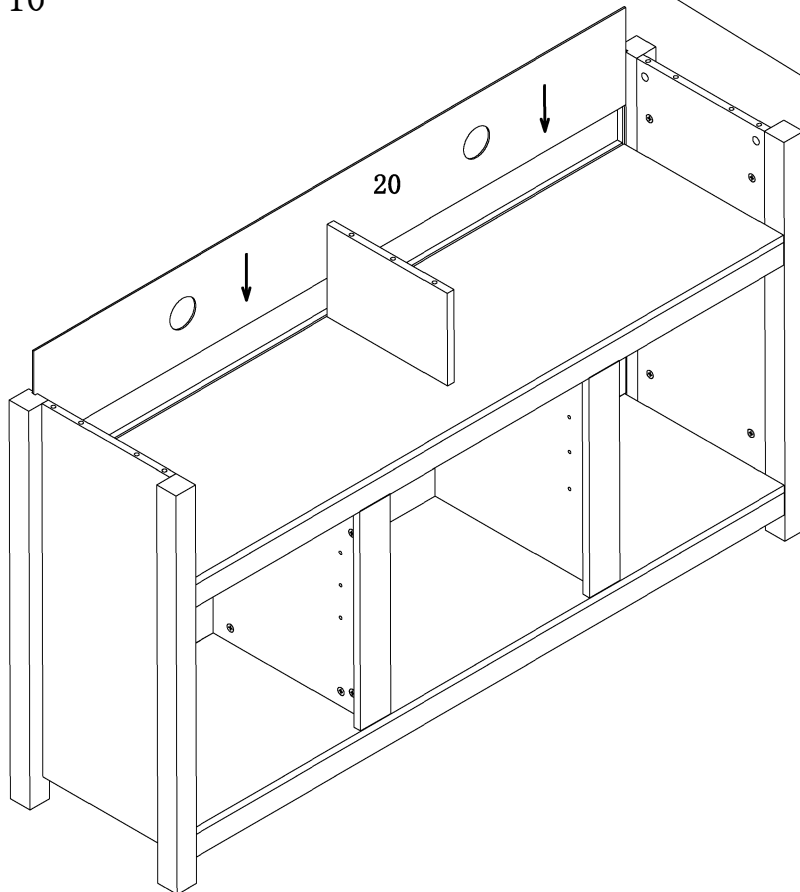

STEP:10



ASSEMBLY INSTRUCTIONS



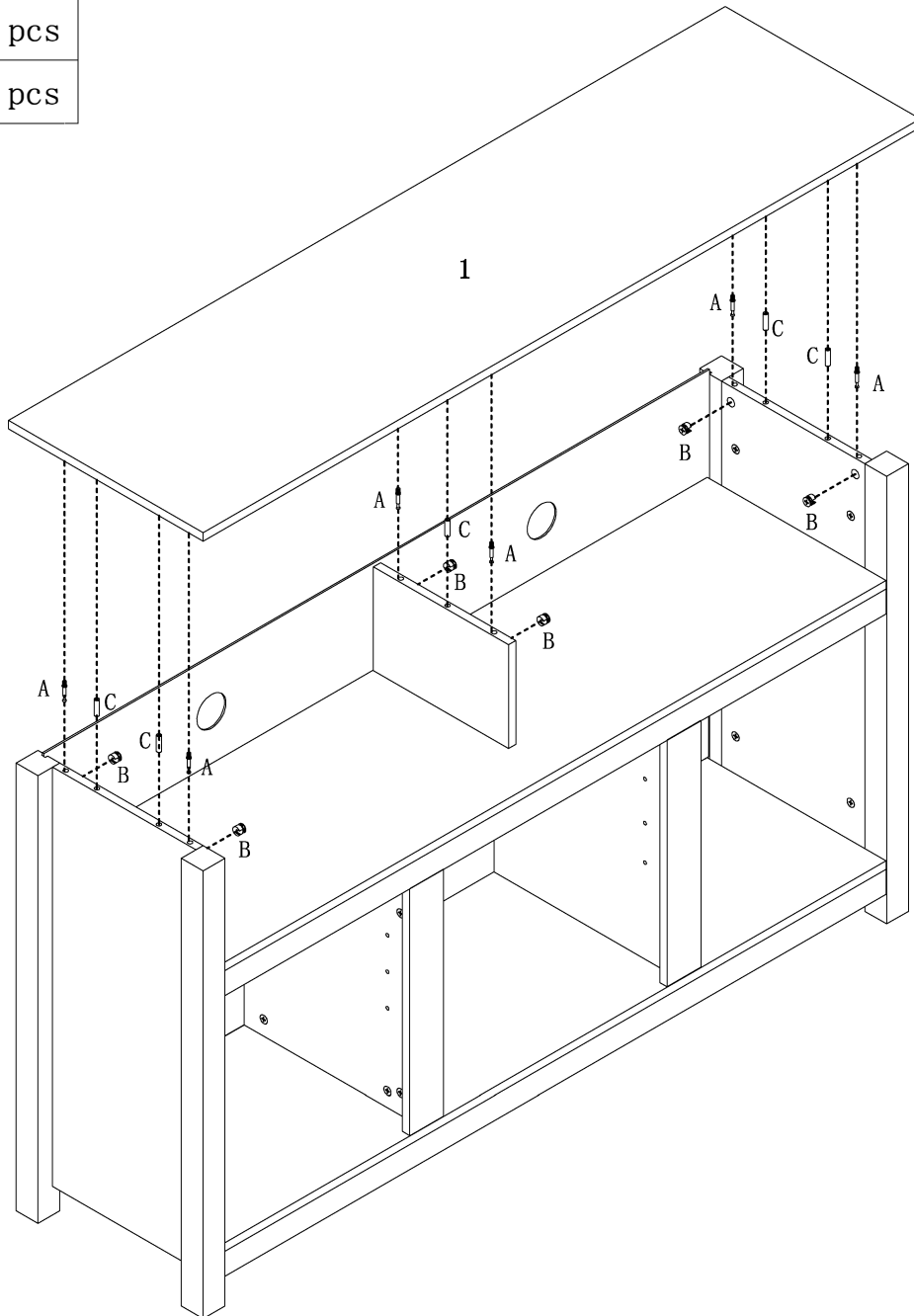

STEP:11

A:		6 pcs
B:		6 pcs
C:		5 pcs



ASSEMBLY INSTRUCTIONS

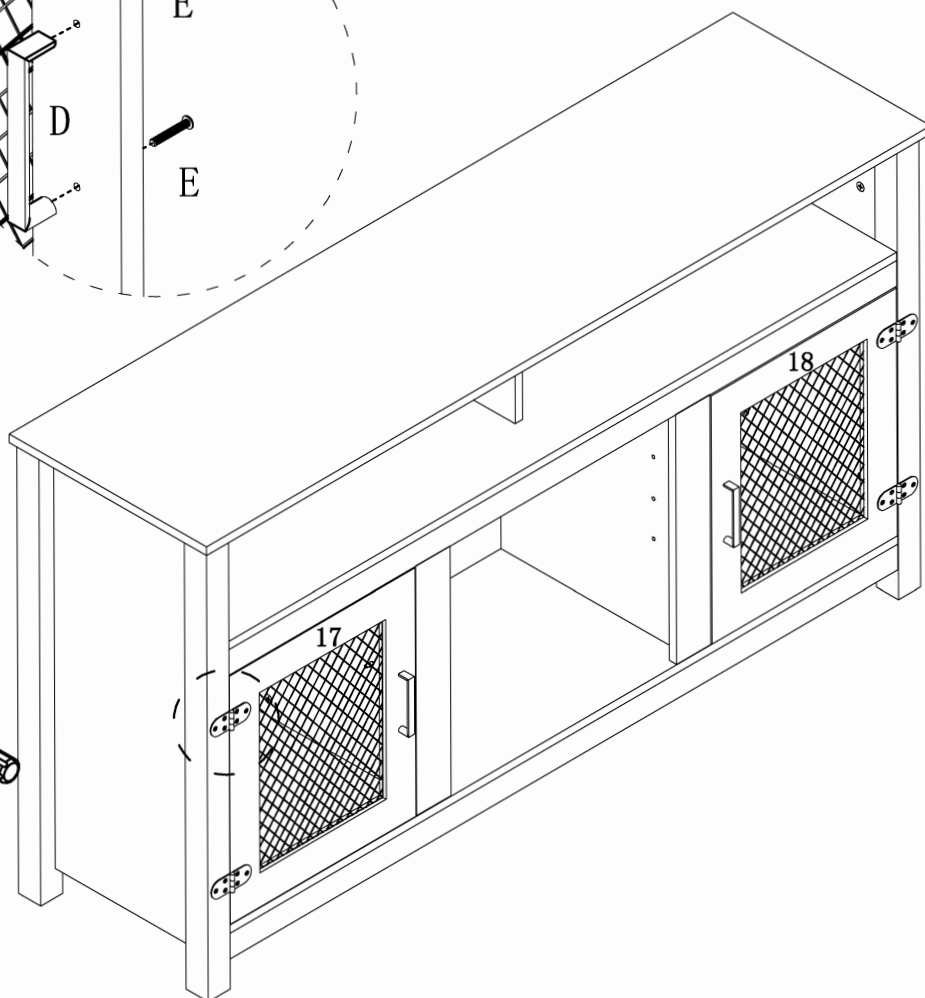
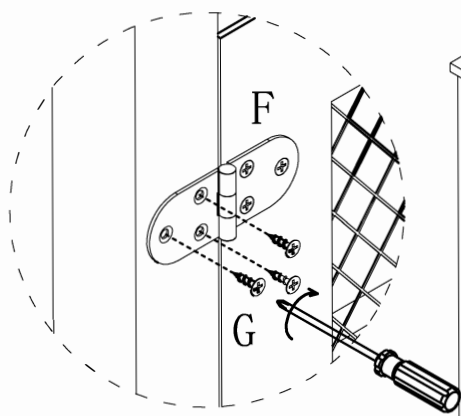
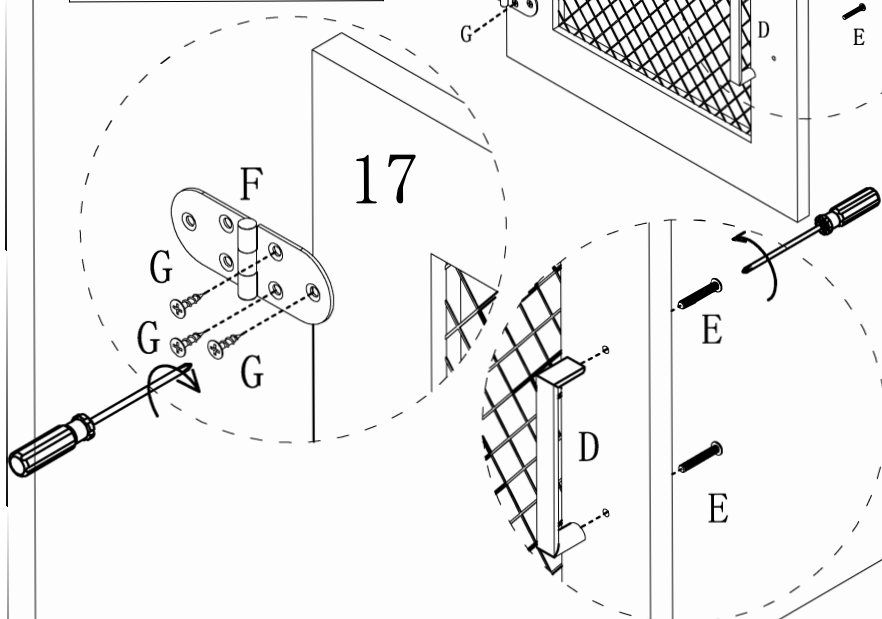
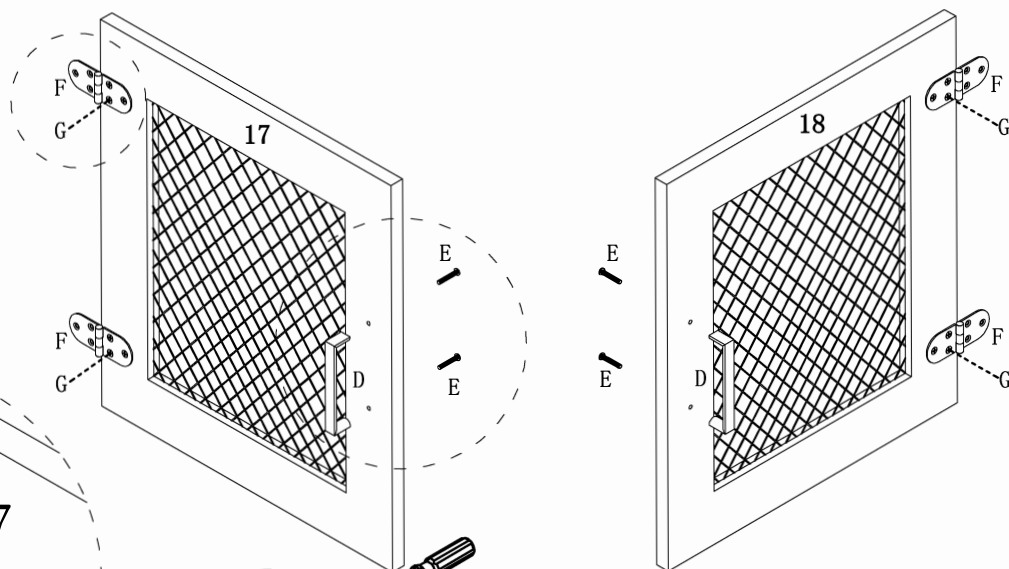

STEP: 12

D:		2 pcs
E:		4 pcs
F:		4 pcs
G:		24 pcs



ASSEMBLY INSTRUCTIONS

STEP:13

screw		14 pcs
N:		12 pcs
G:		12 pcs

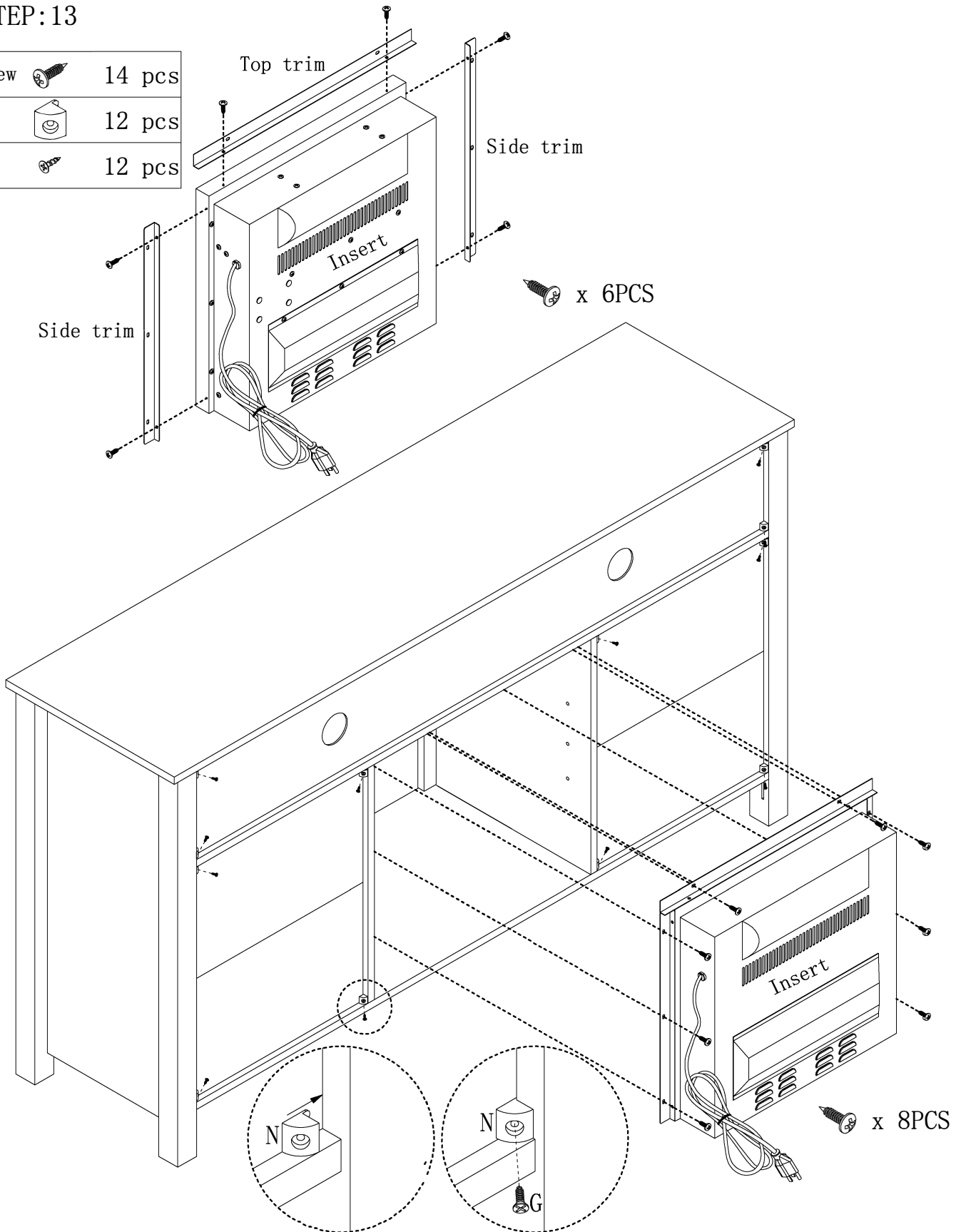

 x 8PCS

ASSEMBLY INSTRUCTIONS

STEP:15

K:  12 pcs

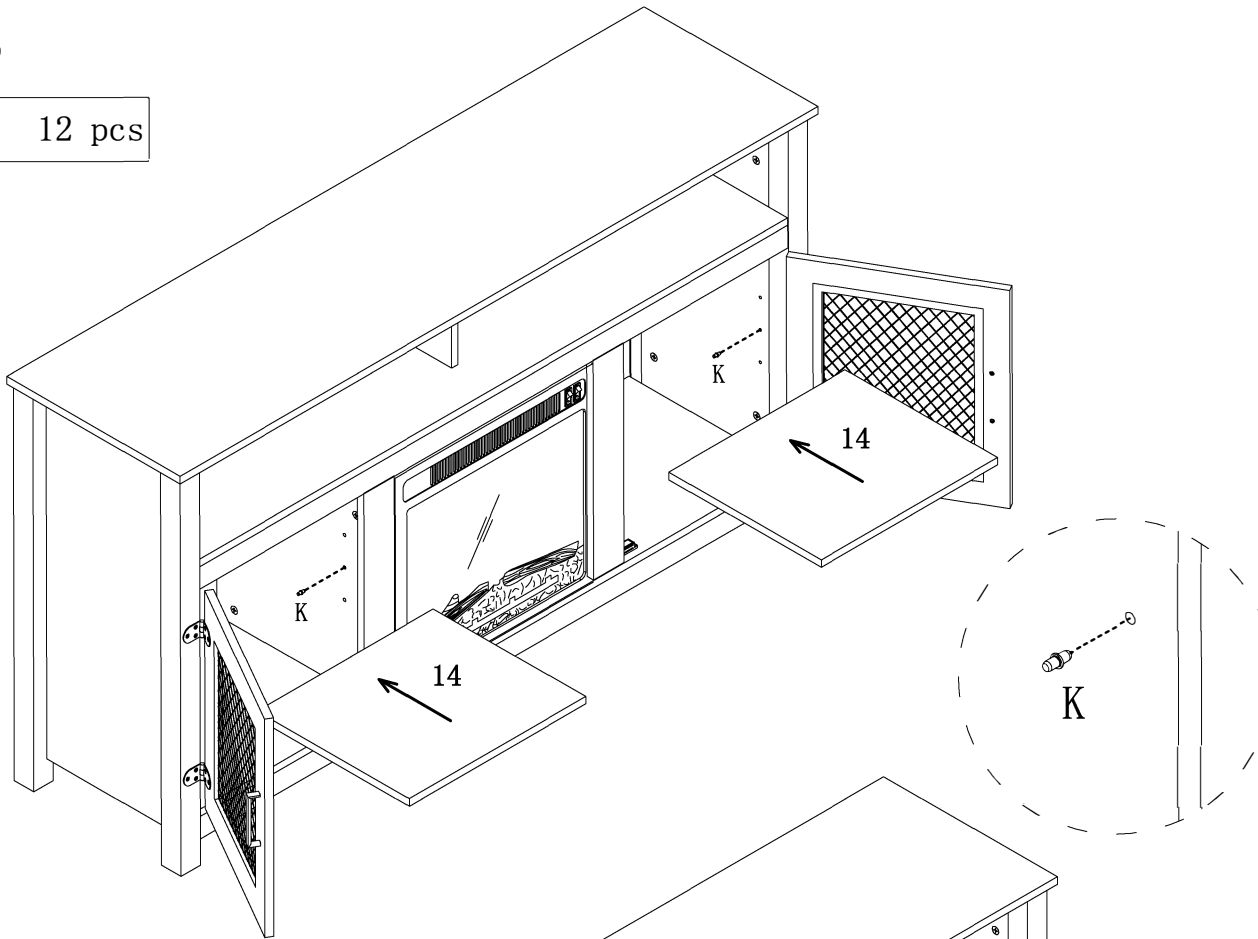



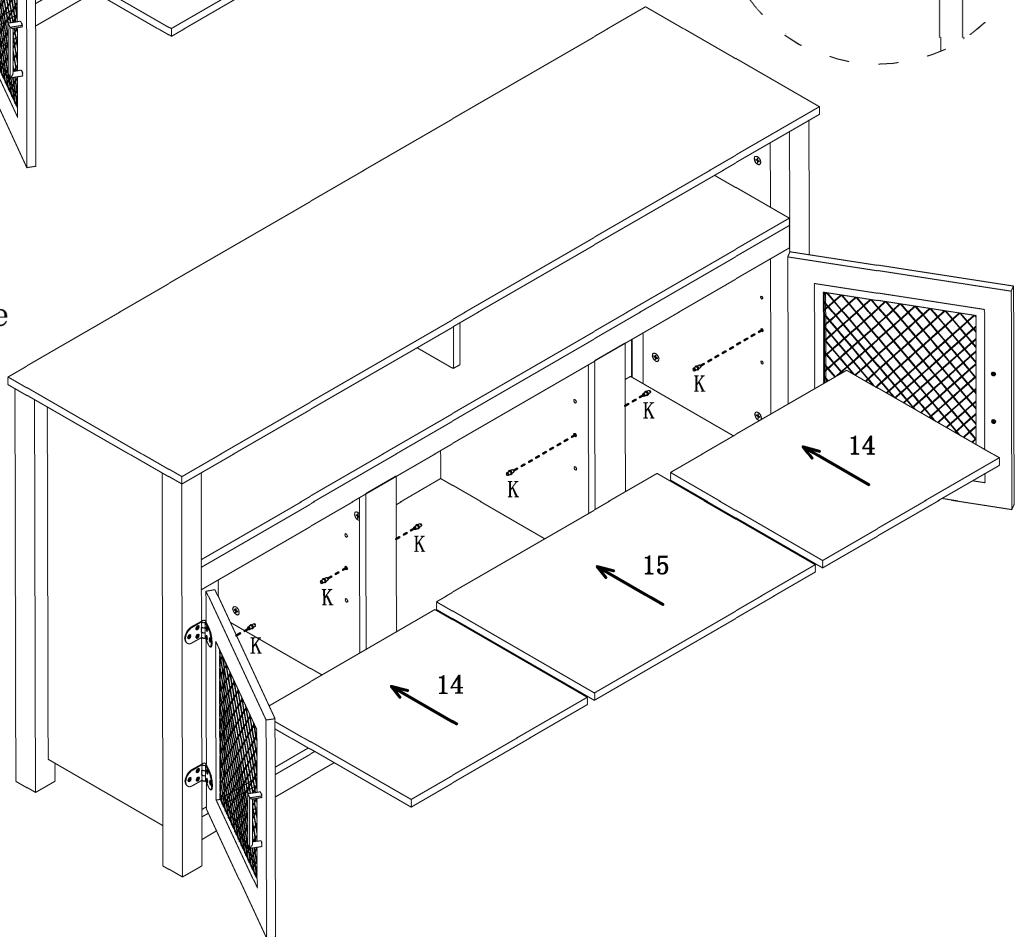

After removing this electric fireplace, it can be covered with middle adjustable shelf(15).



ASSEMBLY INSTRUCTIONS

STEP: 16

H:		1 pcs
L:		1 pcs
M:		1 pcs
O:		1 pcs

