

ASSEMBLY INSTRUCTIONS

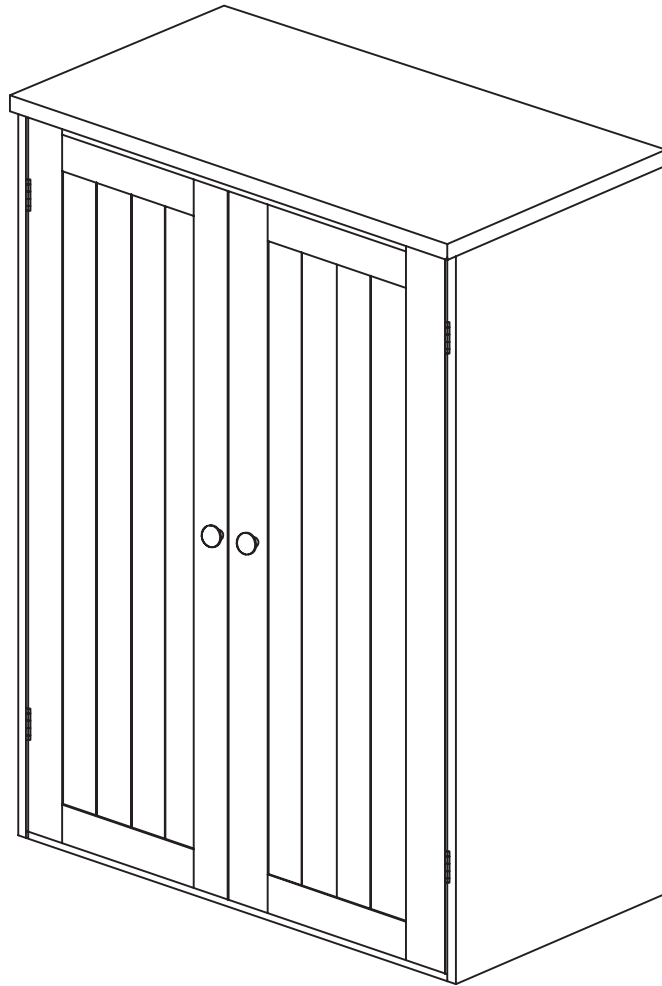

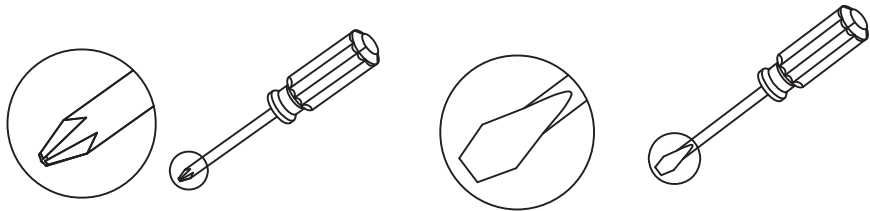



ASSEMBLY TOOLS REQUIRED (NOT INCLUDED)

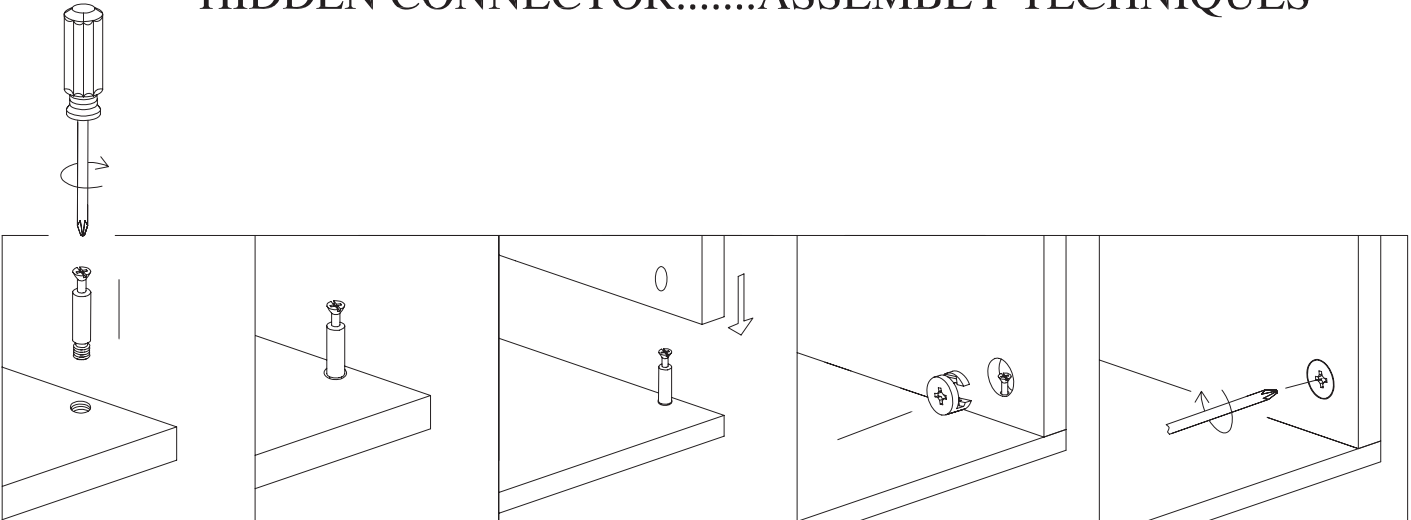



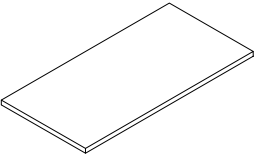

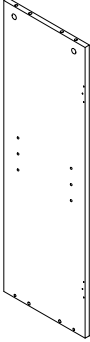
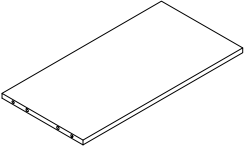
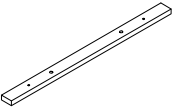
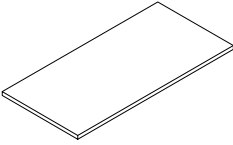

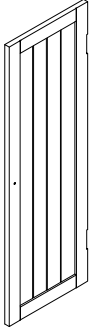
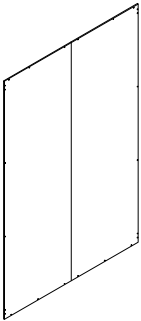



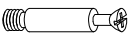







HIDDEN CONNECTOR.....ASSEMBLY TECHNIQUES



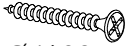

Parts List

<p>1: Top Panel --1 Pc</p> 	<p>2: Left Side Panel -- 1 Pc</p> 	<p>3: Right Side Panel -- 1 Pc</p> 	<p>4: Bottom Panel -- 1 Pc</p> 
<p>5: Front Apron --1 Pc</p> 	<p>6: Adjustable Shelf -- 1 Pc</p> 	<p>7: Left Door -- 1 Pc</p> 	<p>8: Right Door -- 1 Pc</p> 
<p>9: Back Panel -- 1 Pc</p> 			

Hardware List



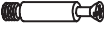

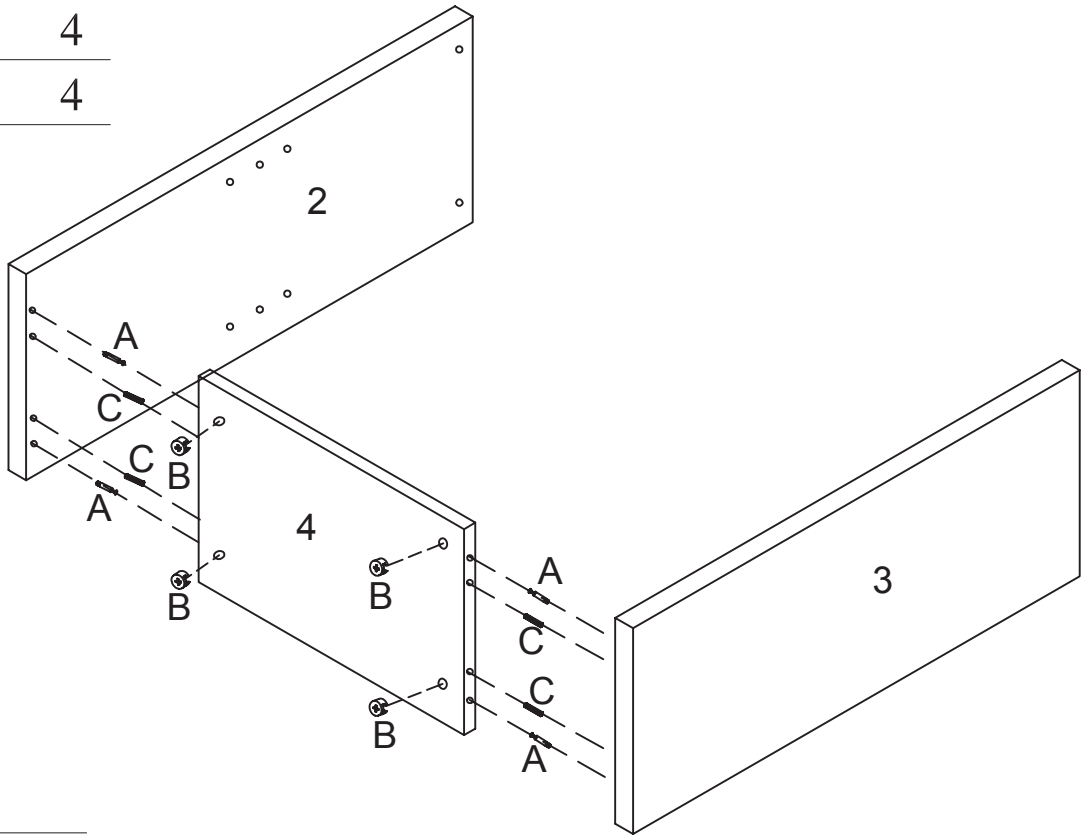

<p>A: Cam Bolt 8 Pcs</p> 	<p>B: Cam Lock 8 Pcs</p> 	<p>C: Wood Dowel 8 Pcs</p>  <p>Ø8*30mm</p>	<p>D: Round Head Screw 22 Pcs</p>  <p>Ø3*12mm</p>	<p>E: Flat Head Screw 30 Pcs</p>  <p>Ø3*12mm</p>	<p>F: Wood Dowel 2 Pcs</p>  <p>Ø8*20mm</p>
<p>G: Knob 2 Pcs</p> 	<p>H: Hinge 4 Pcs</p> 	<p>I: Magnet 1 Pc</p> 	<p>J: Shelf Support 4 Pcs</p> 	<p>K: Flat Head Screw 2 Pcs</p>  <p>Ø4*25mm</p>	<p>L: Magnet Slice 2 Pcs</p> 
<p>M: Machine Screw 2 Pcs</p>  <p>Ø4*19mm</p>	<p>N: Safety Wall Strap 1 Pc</p> 	<p>O: Plastic Anchor 1 Pc</p> 	<p>P: Mounting Screw 1 Pc</p>  <p>Ø4*38mm</p>	<p>Q: Washer 1 Pc</p> 	<p>R: Connecting Piece 2 Pcs</p> 
<p>S: Screw 4Pcs</p>  <p>Ø3*15mm</p>					

STEP 1

A		4
B		4
C		4



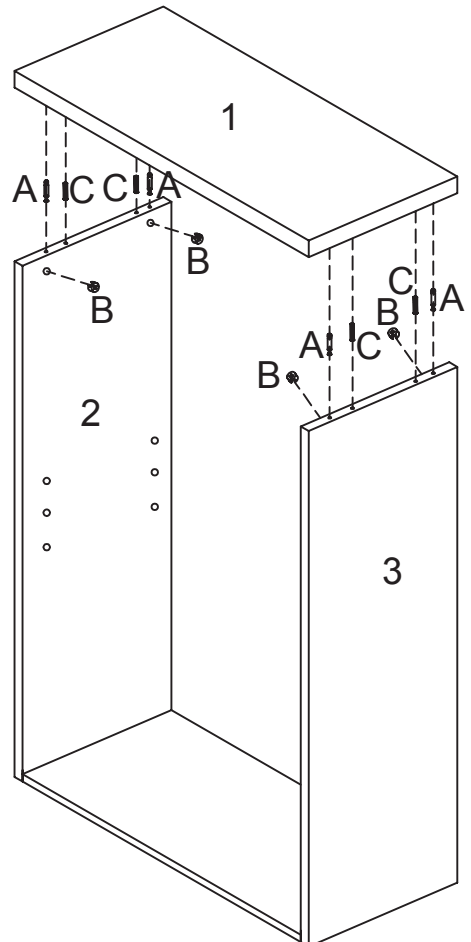
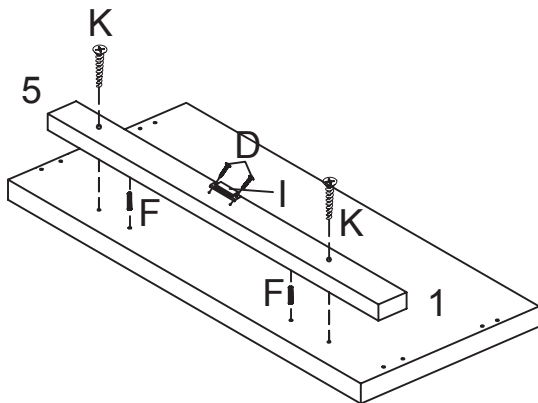

STEP 2

A		4
B		4
C		4
D		2
F		2
I		1
K		2





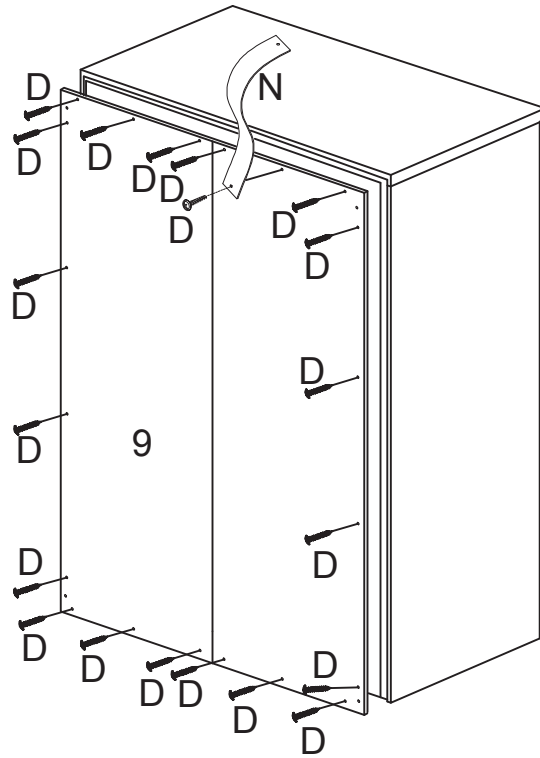

STEP 3

D		20
N		1



STEP 4

E		30
G		2
H		4
I		2
M		2

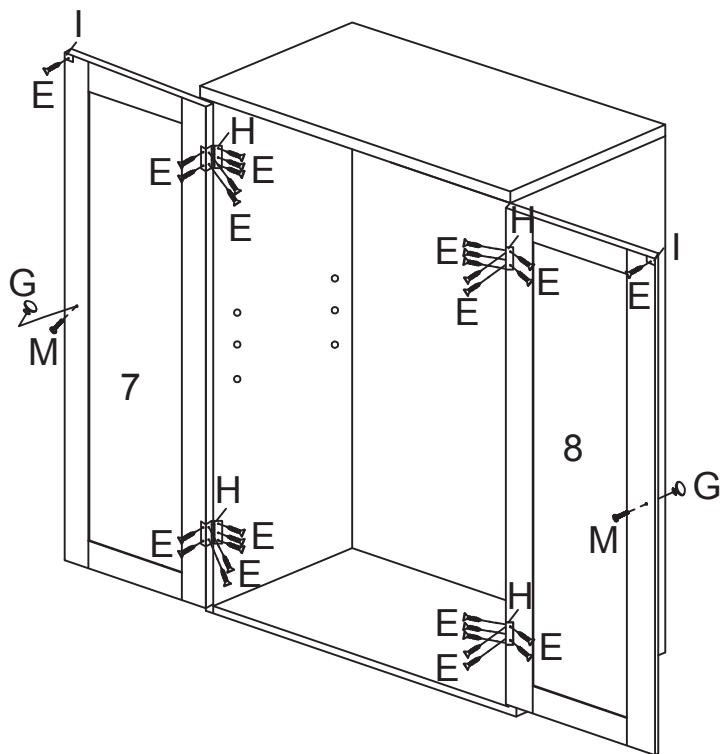

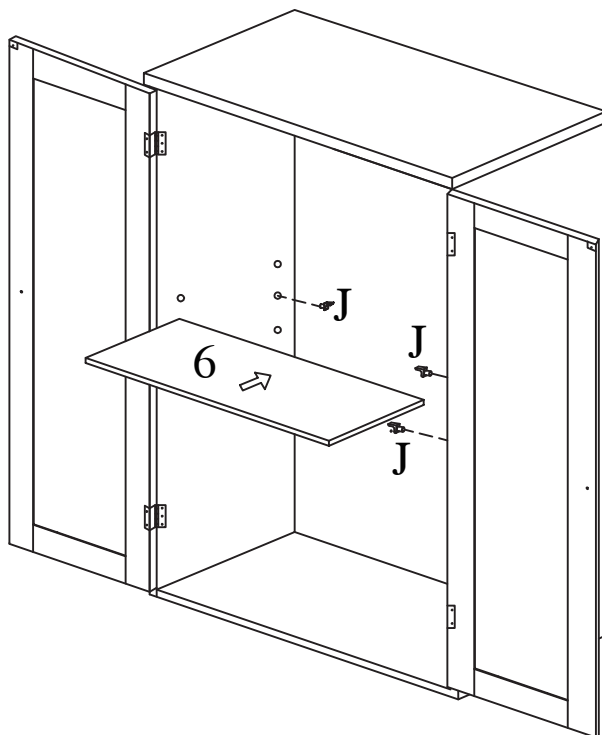

STEP 5

J		4
---	---	---



STEP 6

O		1
P		1
Q		1

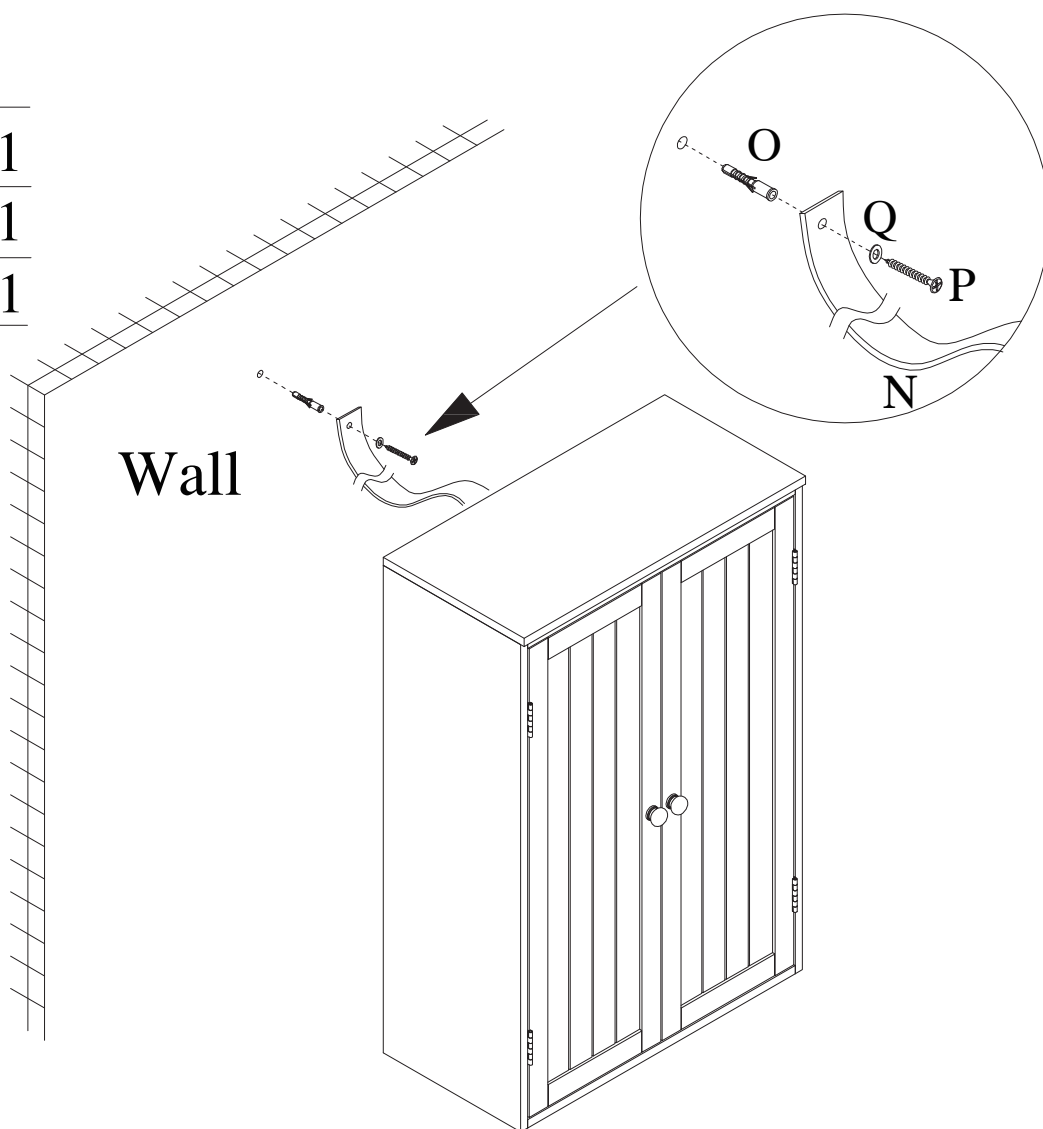

STEP 7

R  2

S  4

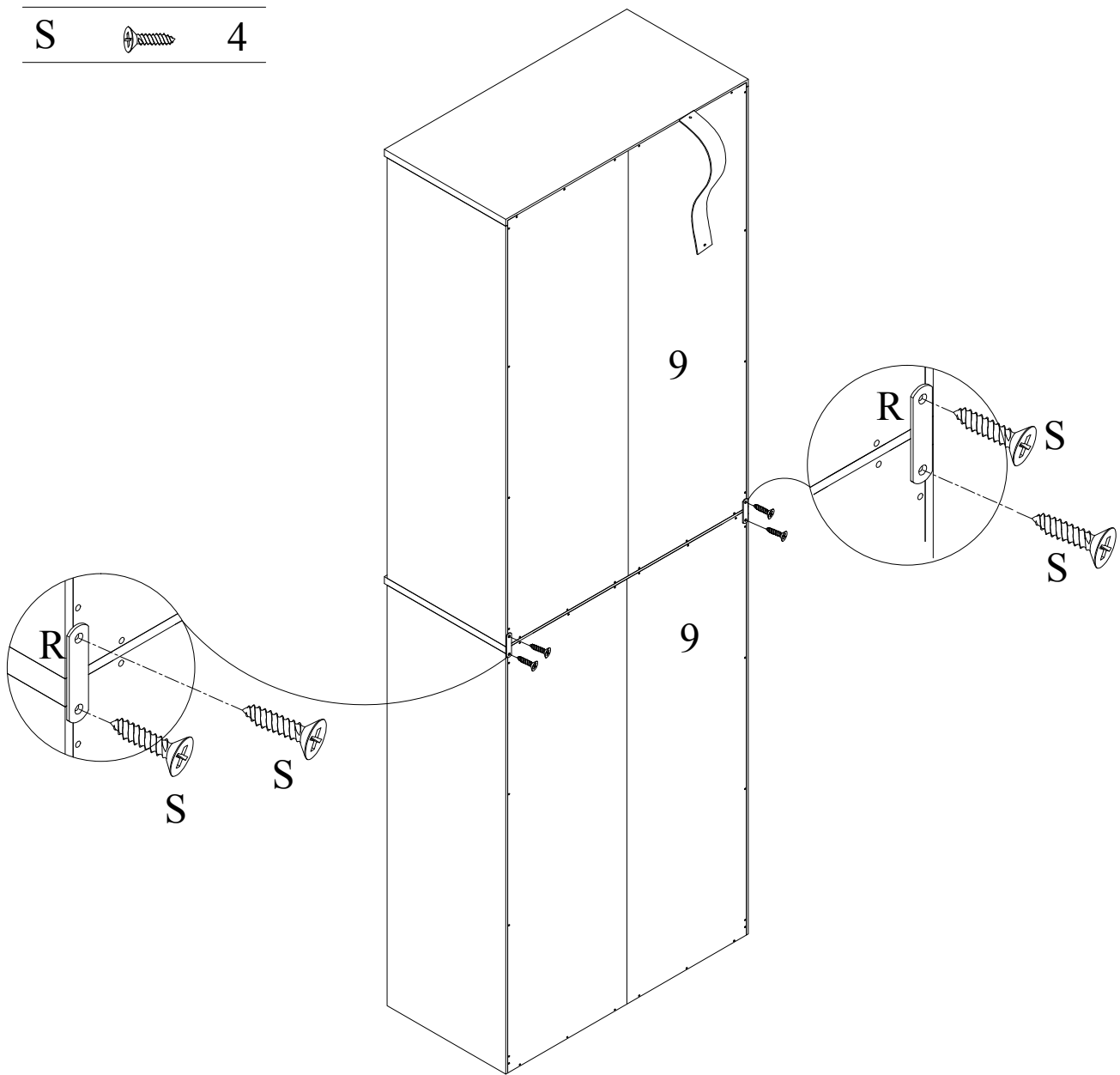

The two cabinets can be connected with Connecting Pieces.