

ASSEMBLY INSTRUCTION (WF324908/324909)

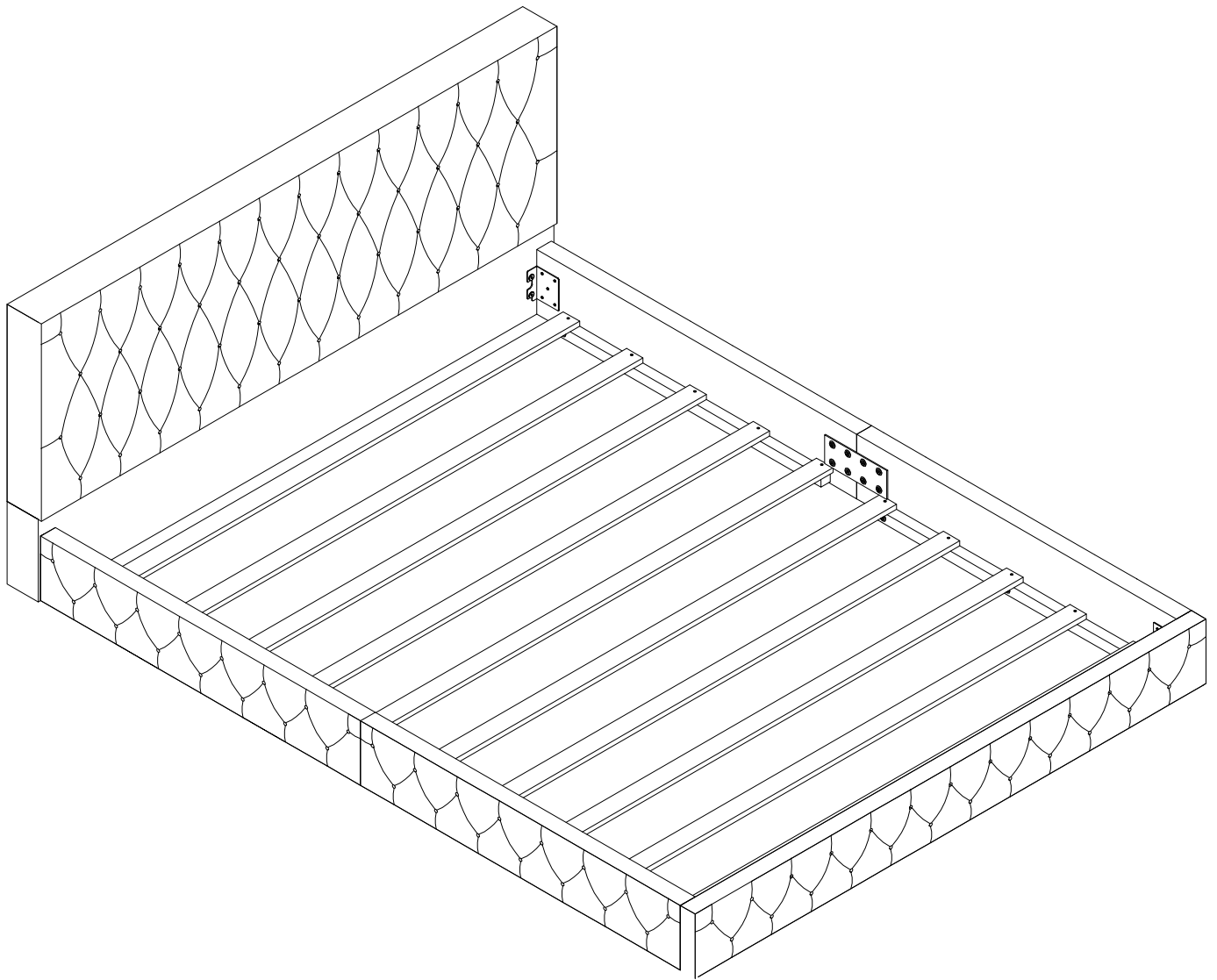

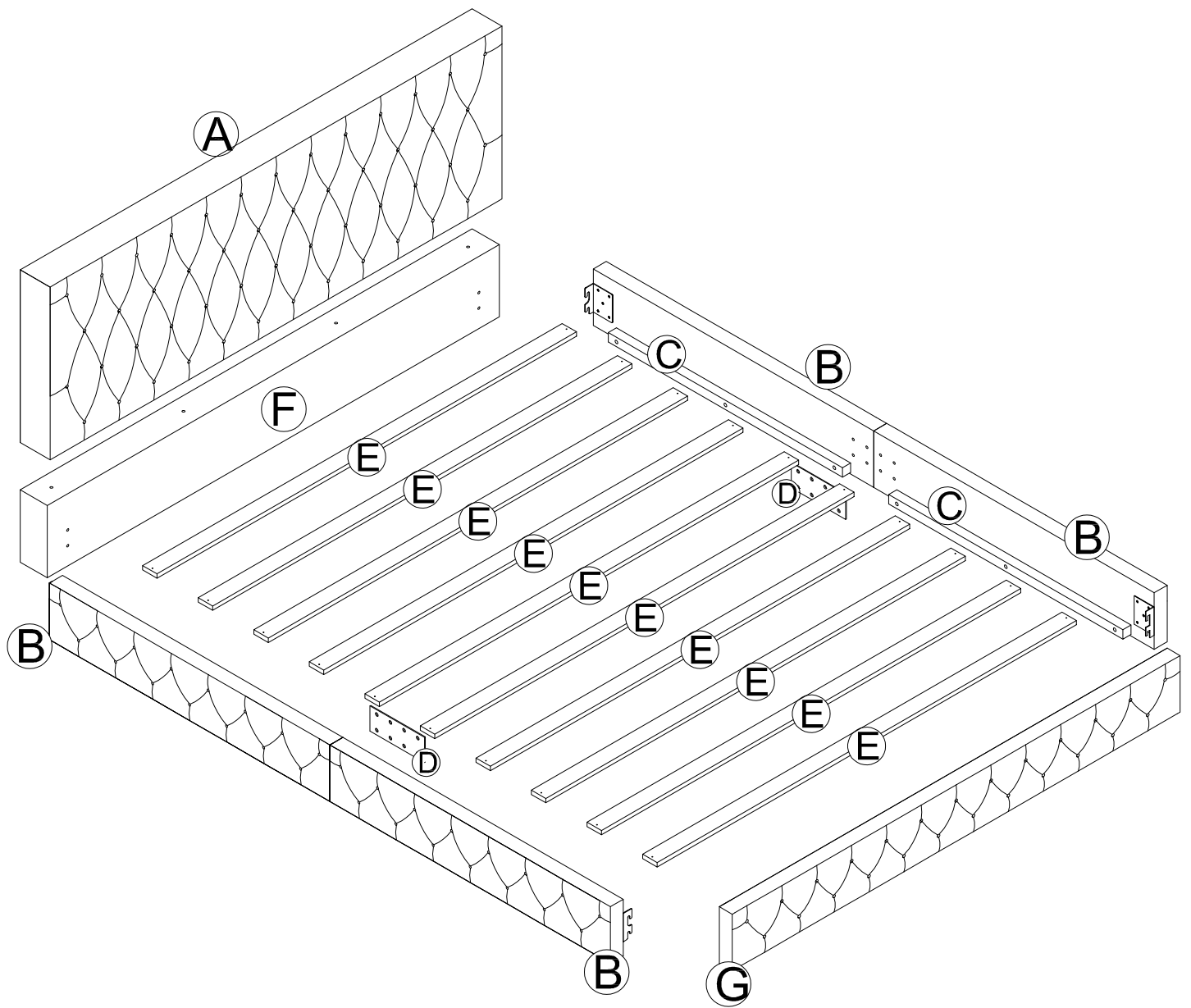

Part List (WF324908)

A

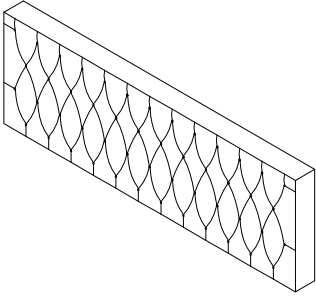

HEADBOARD TOP - 1pc

B

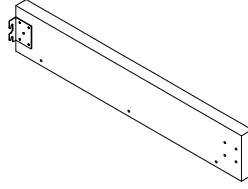

SIDE PANEL - 4pcs

C

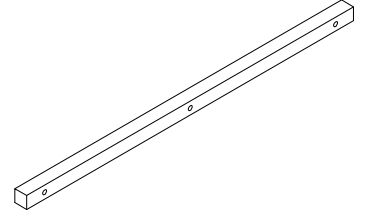

SIDE WOOD BASE - 4pcs

D

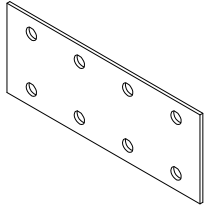

SIDE PANEL SUPPORT - 2pcs

E

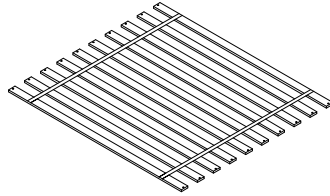

SLAT - 1SET/10pcs

Part List (WF324909)

F

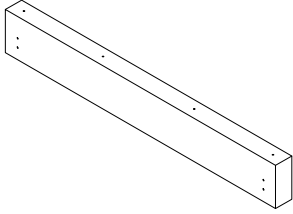

HEADBOARD BOTTOM - 1pc

G

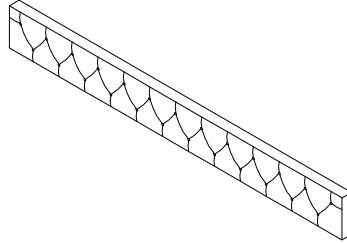

FOOTBOARD - 1pc

Hardware List (WF324908)

1

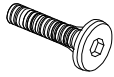

JCBB M8 x 16mm (8 pcs)

2

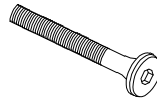

JCBC M6 x 35mm (16 pcs)

3

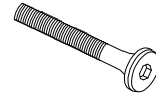

JCBC M6 x 45mm (16 pcs)

4

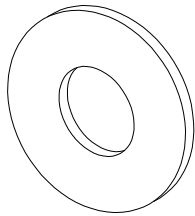

M6 Flat Washer (32 pcs)

5

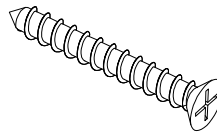

CSK SCREW M4 x 30mm (20pcs)

6

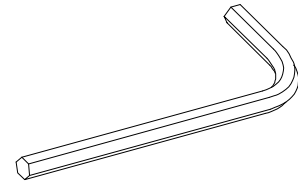

Allen Key M4 (1pcs)

7

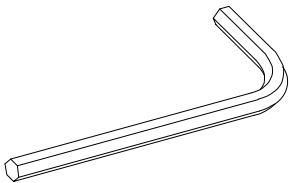

Allen Key M5 (1pcs)

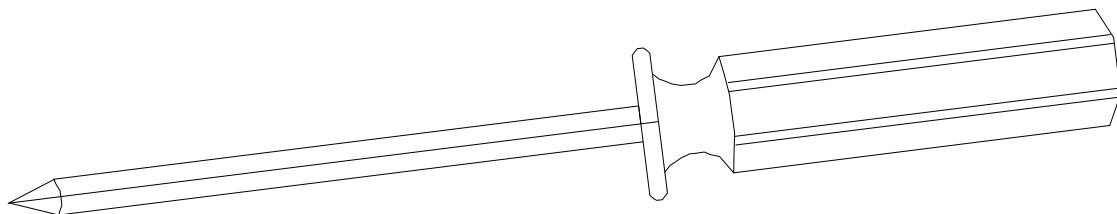

Assembly Tools
Required (Not Included)

Assembly Step

1

4x

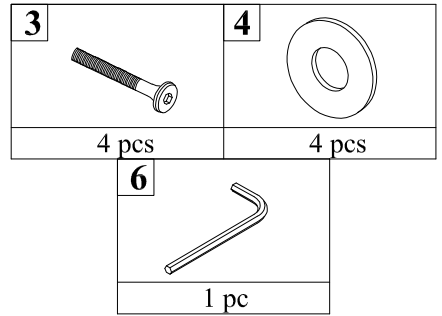
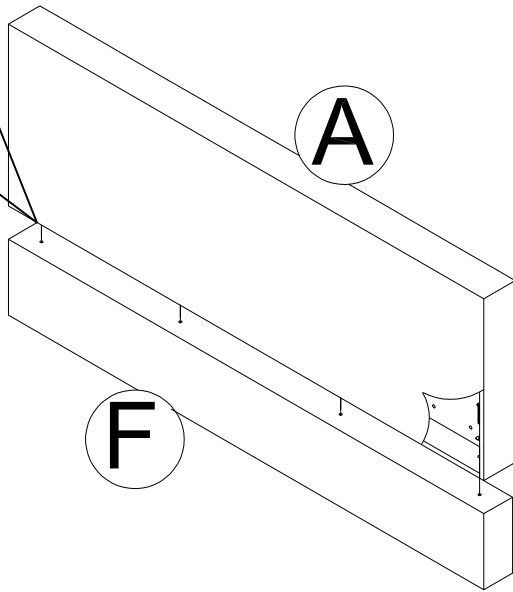
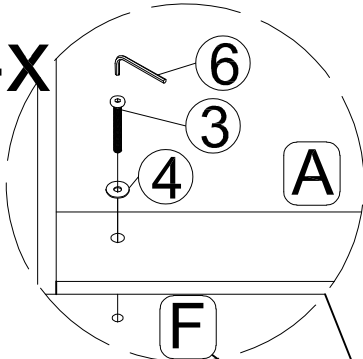

2

12x

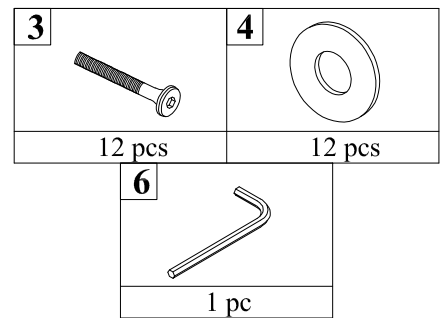
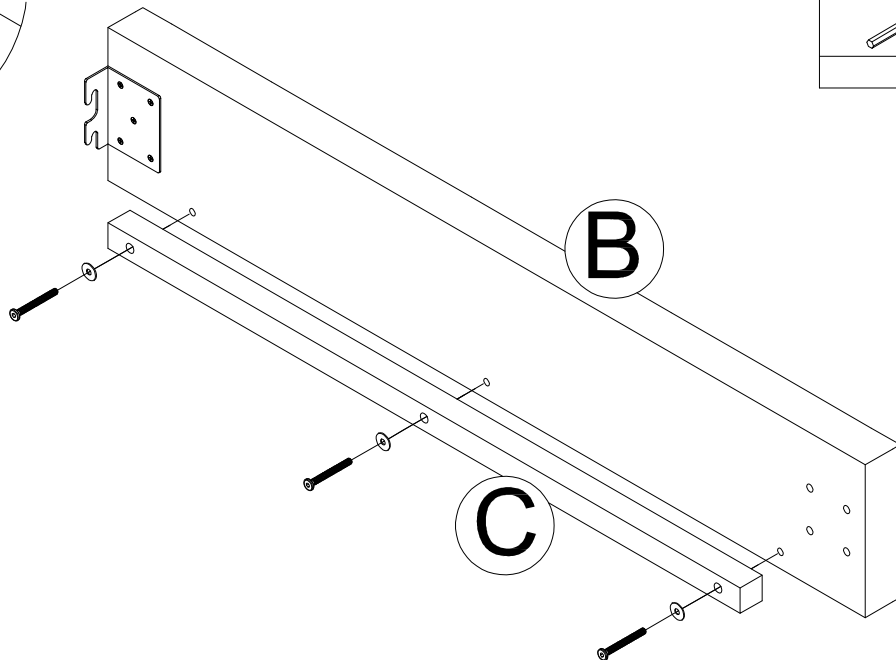
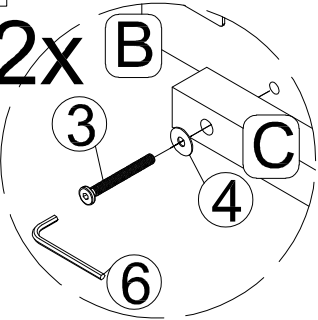

Assembly Step

3

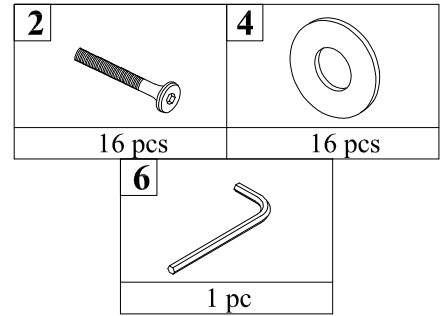
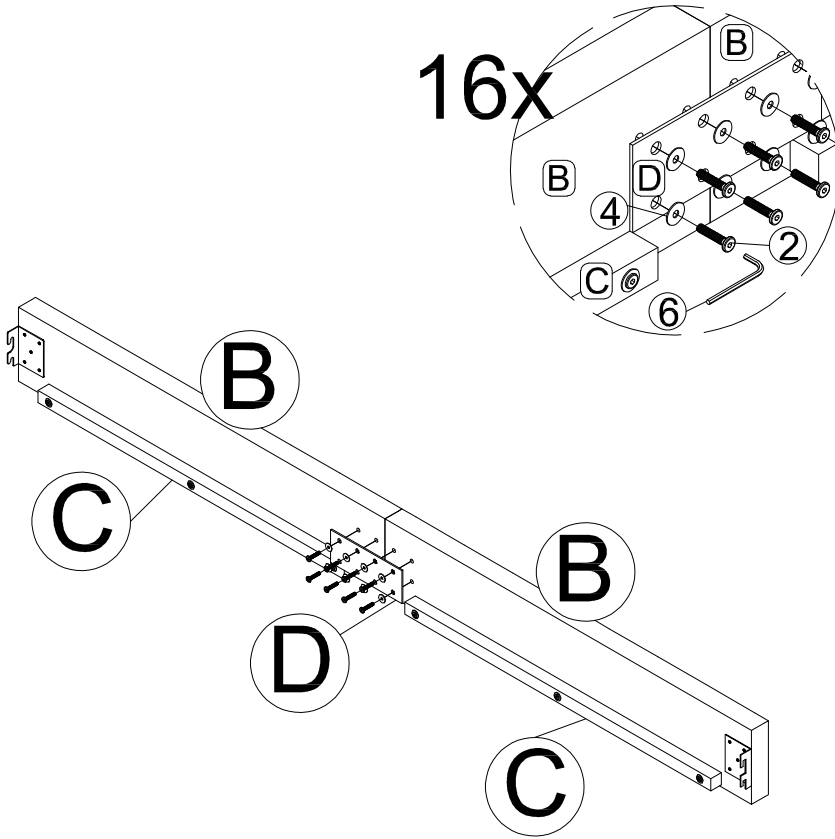

4

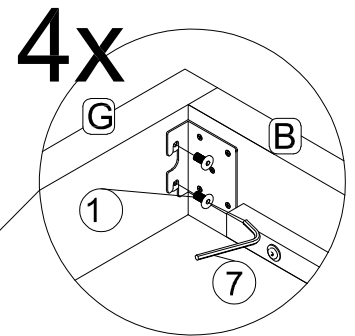
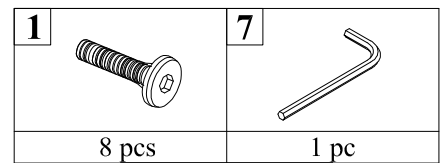
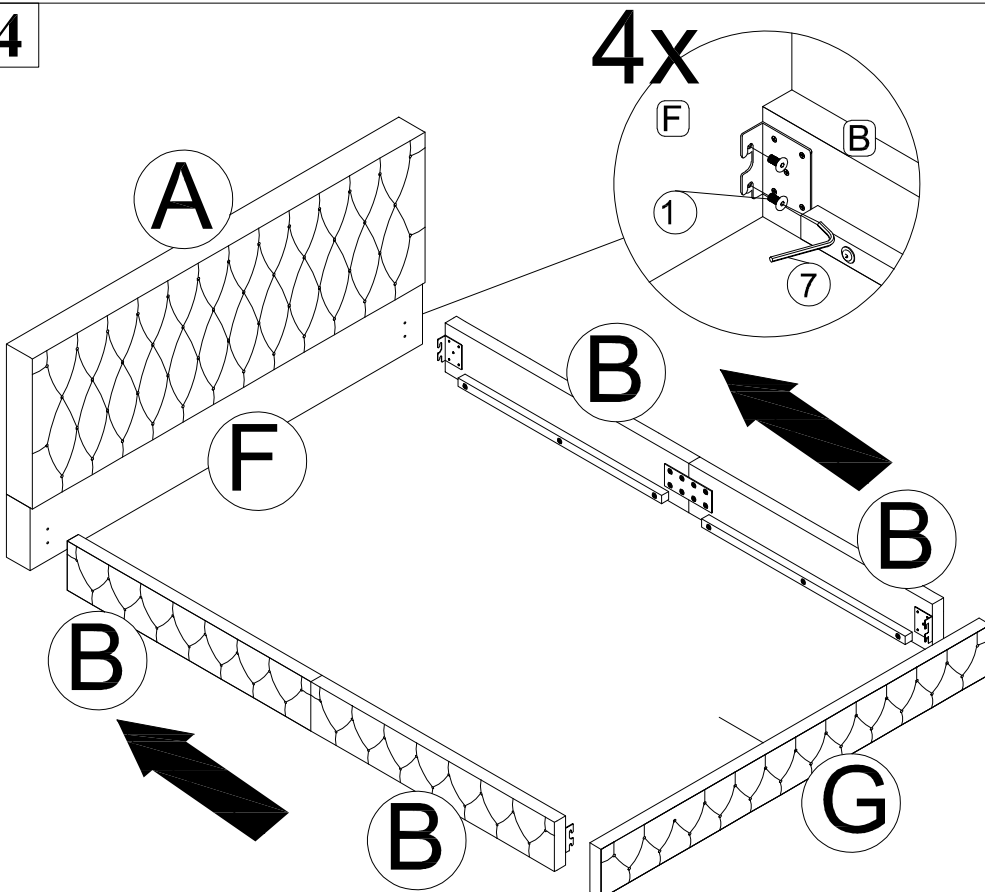

Assembly Step

5

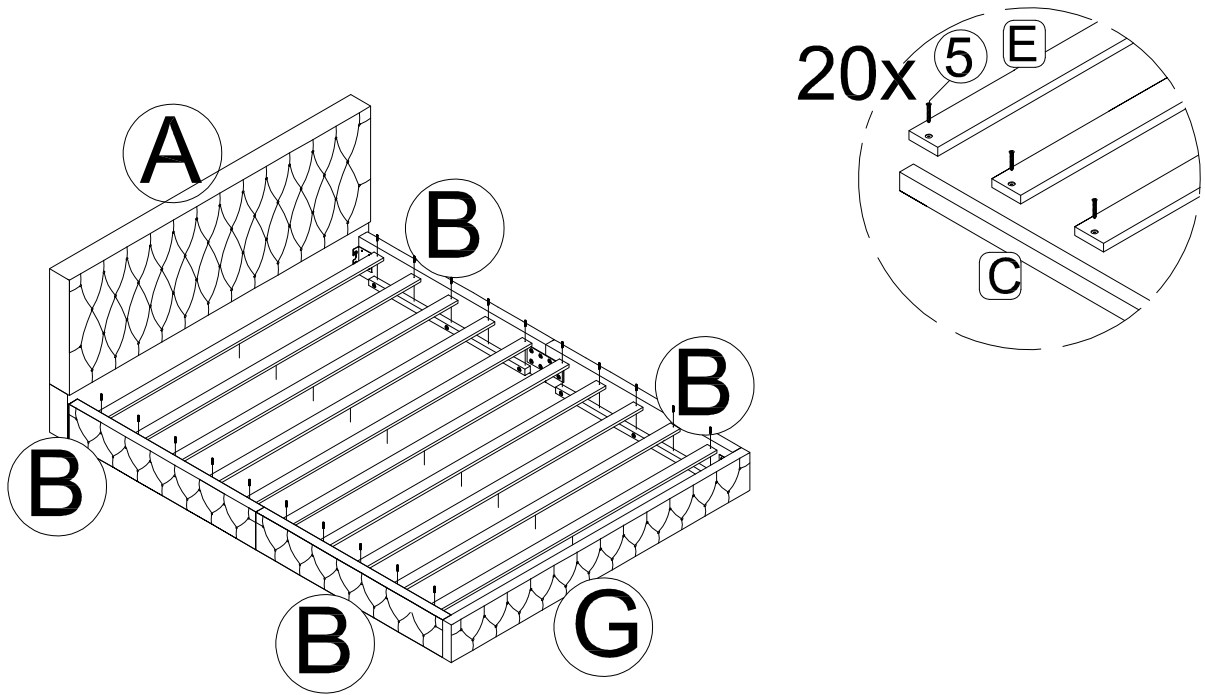
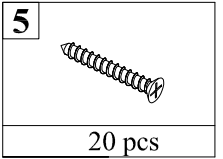

FULLY COMPLETED ASSEMBLY

