

ASSEMBLY INSTRUCTION

SKU CODE: (N733P180009)

INSTRUCTIONS DE MONTAGE

SKU CODE: (N733P180009)

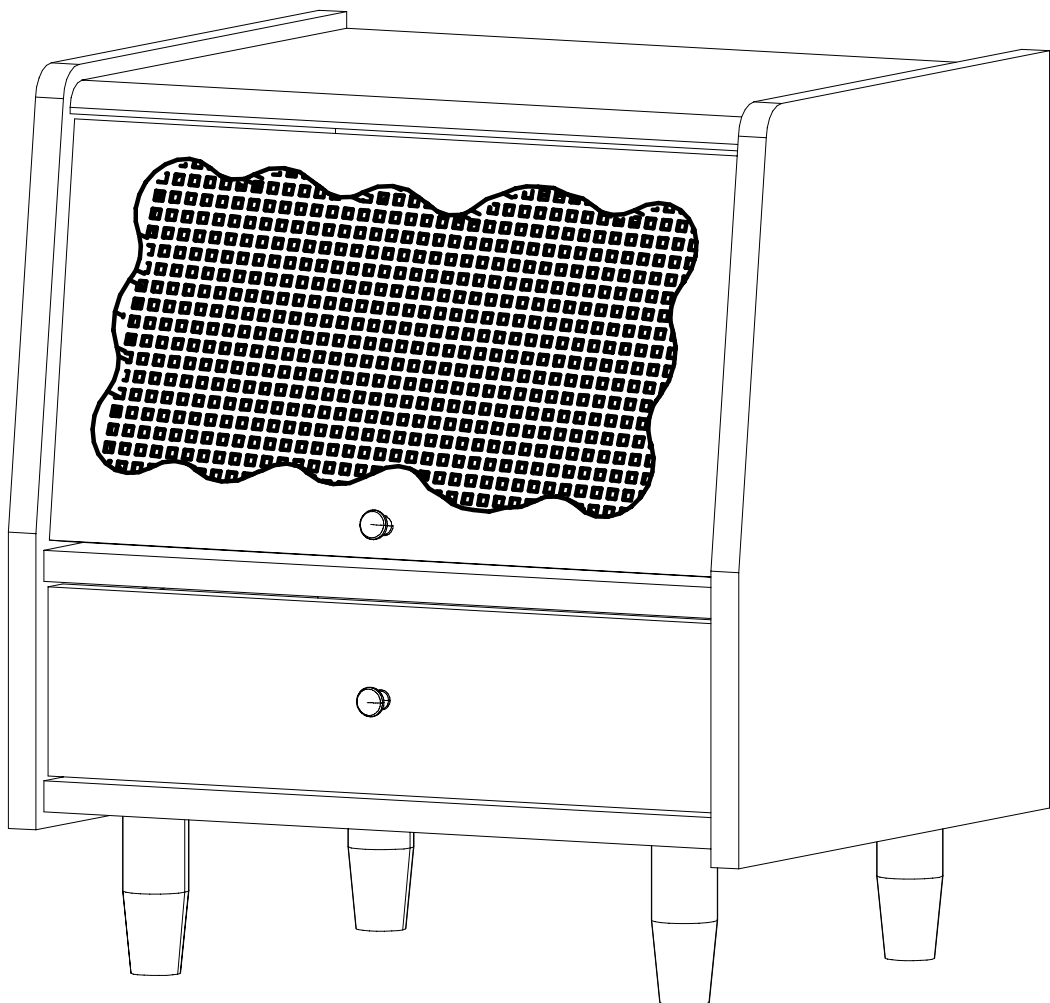

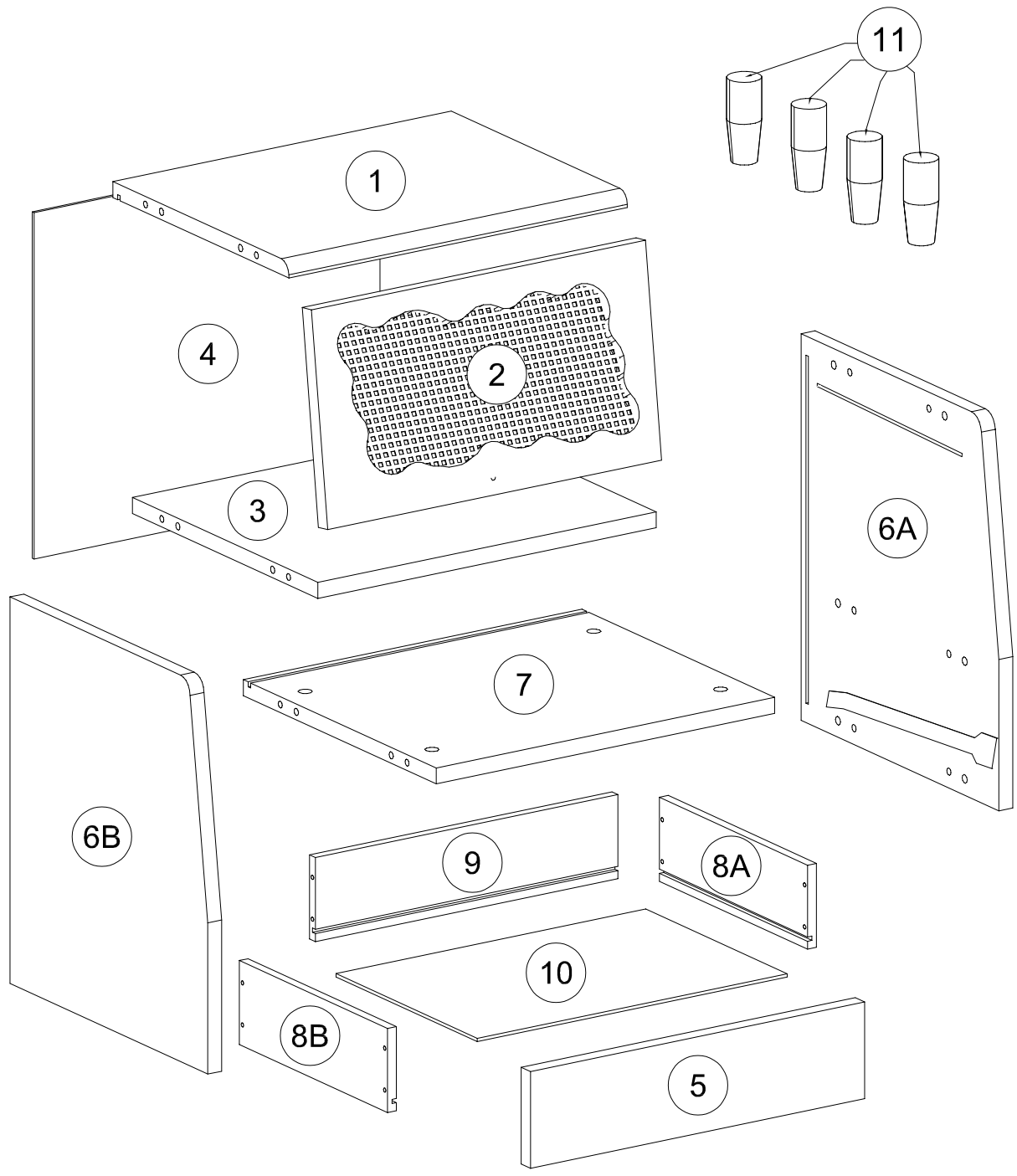

ASSEMBLY INSTRUCTION

INSTRUCTIONS DE MONTAGE





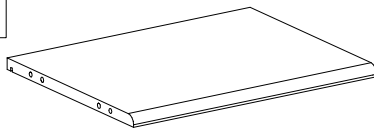
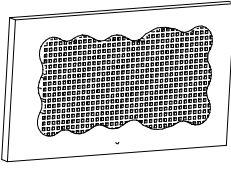
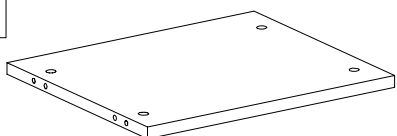

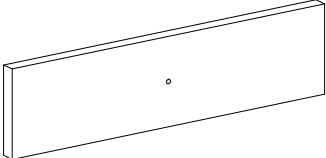
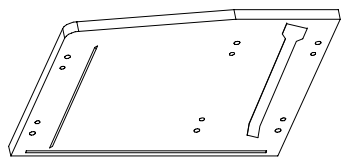
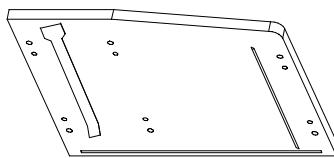
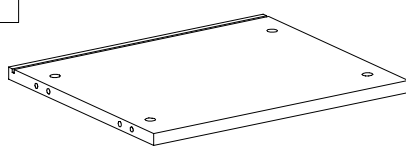
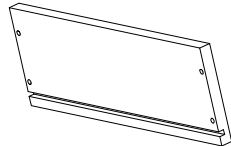
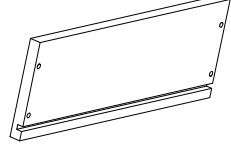
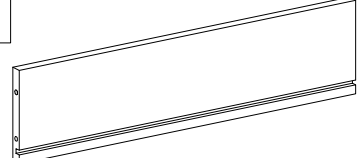
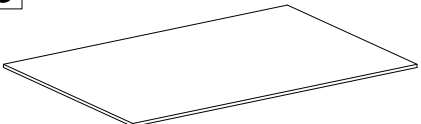
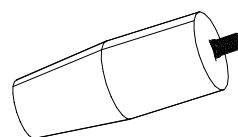
Part List (N733P180009)

Liste des pièces(N733P180009)

<p>1</p>  <p>The top of the cabinet-1pc Le dessus du meuble-1pièces</p>	<p>2</p>  <p>CABINET WINGS-1pc AILES D'ARMOIRE-1pièces</p>	<p>3</p>  <p>FIXED SHELF-1pc ÉTAGÈRE FIXE-1pièces</p>
<p>4</p>  <p>Cabinet Back-1pc Armoire arrière-1pièces</p>	<p>5</p>  <p>DRAWER-FRONT Panels-1pc Panneaux AVANT DE TIROIR-1pièces</p>	<p>6A</p>  <p>SIDE EDGE OF CABINET-1pc BORD LATÉRAL DE L'ARMOIRE-1pièces</p>
<p>6B</p>  <p>SIDE EDGE OF CABINET-1pc BORD LATÉRAL DE L'ARMOIRE-1pièces</p>	<p>7</p>  <p>CABINET BOTTOM-1pc FOND D'ARMOIRE-1pièces</p>	<p>8A</p>  <p>DRAWER-SIDE Panels-1pc Panneaux CÔTÉ TIROIR-1pièces</p>
<p>8B</p>  <p>DRAWER-SIDE Panels-1pc Panneaux CÔTÉ TIROIR-1pièces</p>	<p>9</p>  <p>DRAWER-Back Panels-1pc Panneaux arrière de tiroir-1pièces</p>	<p>10</p>  <p>Panel- 1pc Panneau- 1pièces</p>
<p>11</p>  <p>CABINET FEET- 4pcs PIEDS D'ARMOIRE- 4pièces</p>		

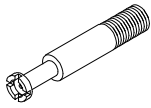
Hardware List (N733P180009)

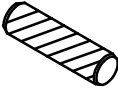
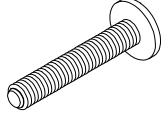
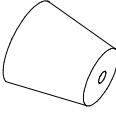
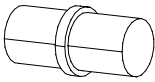
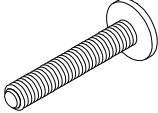
Liste du matériel(N733P180009)

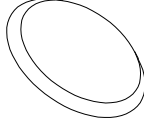

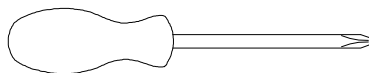

<p>A</p>  <p>Link 1 - 12 pcs Lien 1 - 12pièces</p>	<p>B</p>  <p>Link 2 - 12 pcs Lien 2 - 12pièces</p>	<p>C</p>  <p>Ø8 x 30 mm Wood dowel 12pcs Cheville en bois Ø8 x 30 mm 12pièces</p>
<p>D</p>  <p>M4 x 35mm Hex-Head bolts 1pc Boulons à tête hexagonale M4 x 35 mm 1pièces</p>	<p>E</p>  <p>CABINET DOOR HANDLES - 2pcs POIGNÉES DE PORTE D'ARMOIRE - 2pièces</p>	<p>F</p>  <p>Support Pin 6 pcs Broche de soutien 6pièces</p>
<p>G</p>  <p>M4 x 25mm Hex-Head bolts 1pc Boulons à tête hexagonale M4 x 25 mm 1pièces</p>	<p>H</p>  <p>#4 x 30 mm Wood Screws 8pcs Vis à bois n° 4 x 30 mm 8pièces</p>	<p>I</p>  <p>Plastic button 12pcs Boutons en plastique 12pièces</p>

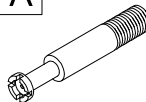

Assembly Tools Required (Not Included)
Outils d'assemblage requis (non inclus)

STEP 1: Following below illustration:

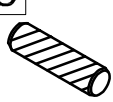

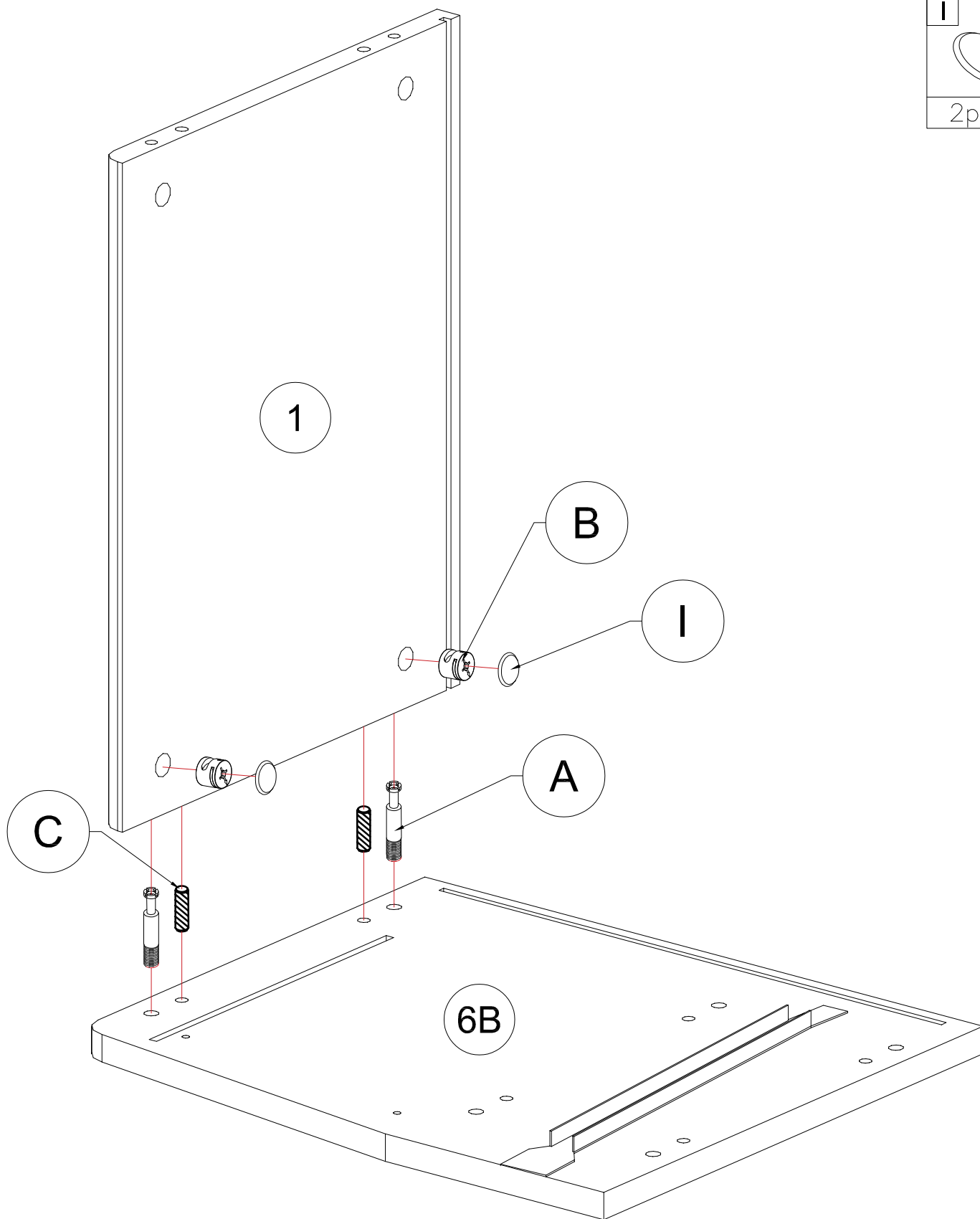

ÉTAPE 1 : Suivez l'illustration ci-dessous :

A 	B 	C 
2pcs	2pcs	2pcs
I 		
2pcs		

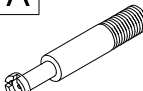

STEP 2: Following below illustration:

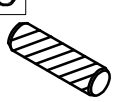

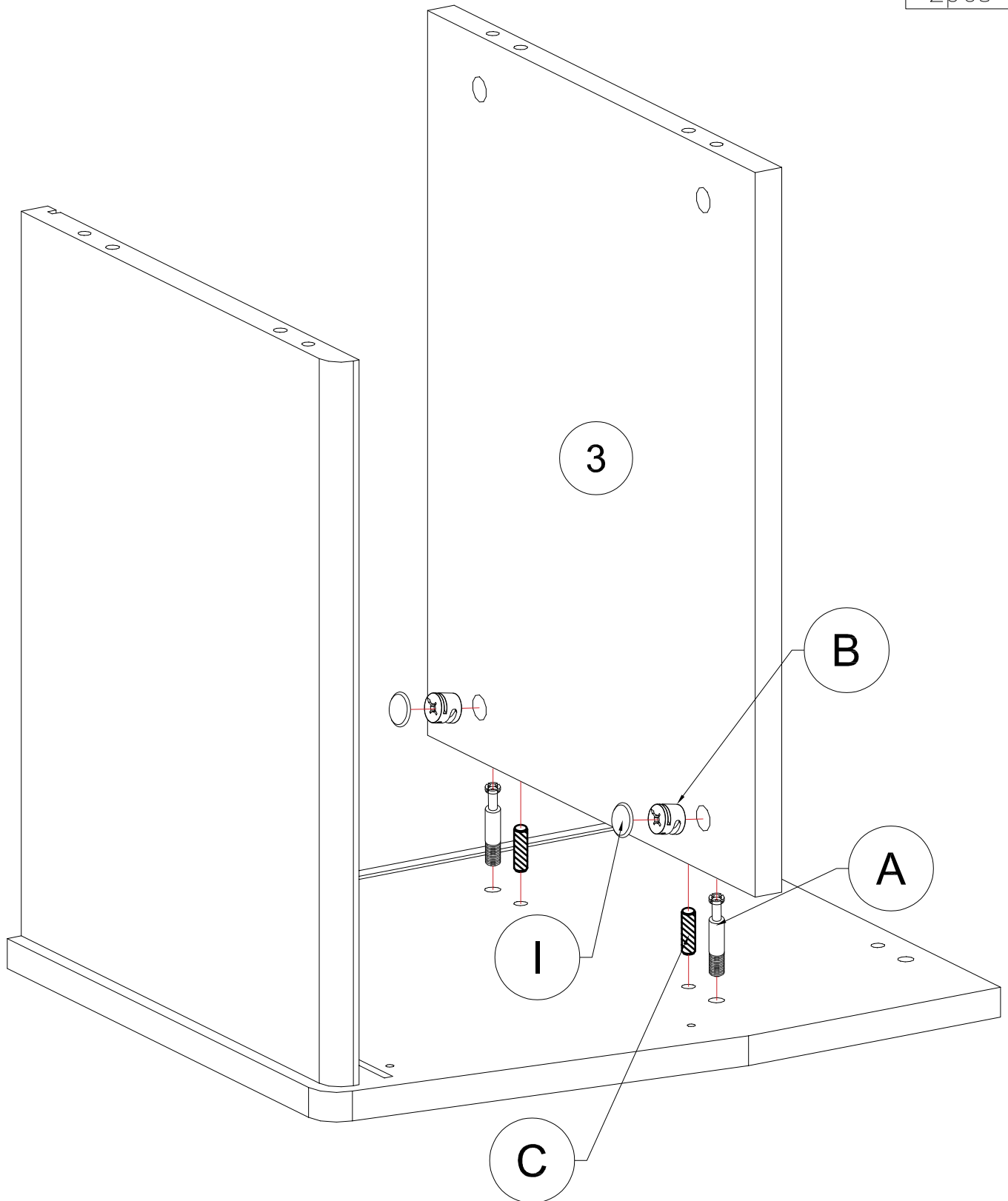

ÉTAPE 2 : Suivez l'illustration ci-dessous :

A 	B 	C 
2pcs	2pcs	2pcs
I 		
2pcs		

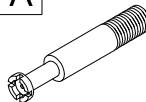

STEP 3: Following below illustration:

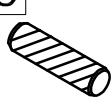
ÉTAPE 3 : Suivez l'illustration ci-dessous :

A 	B 	C 
2pcs	2pcs	2pcs
I 		
2pcs		

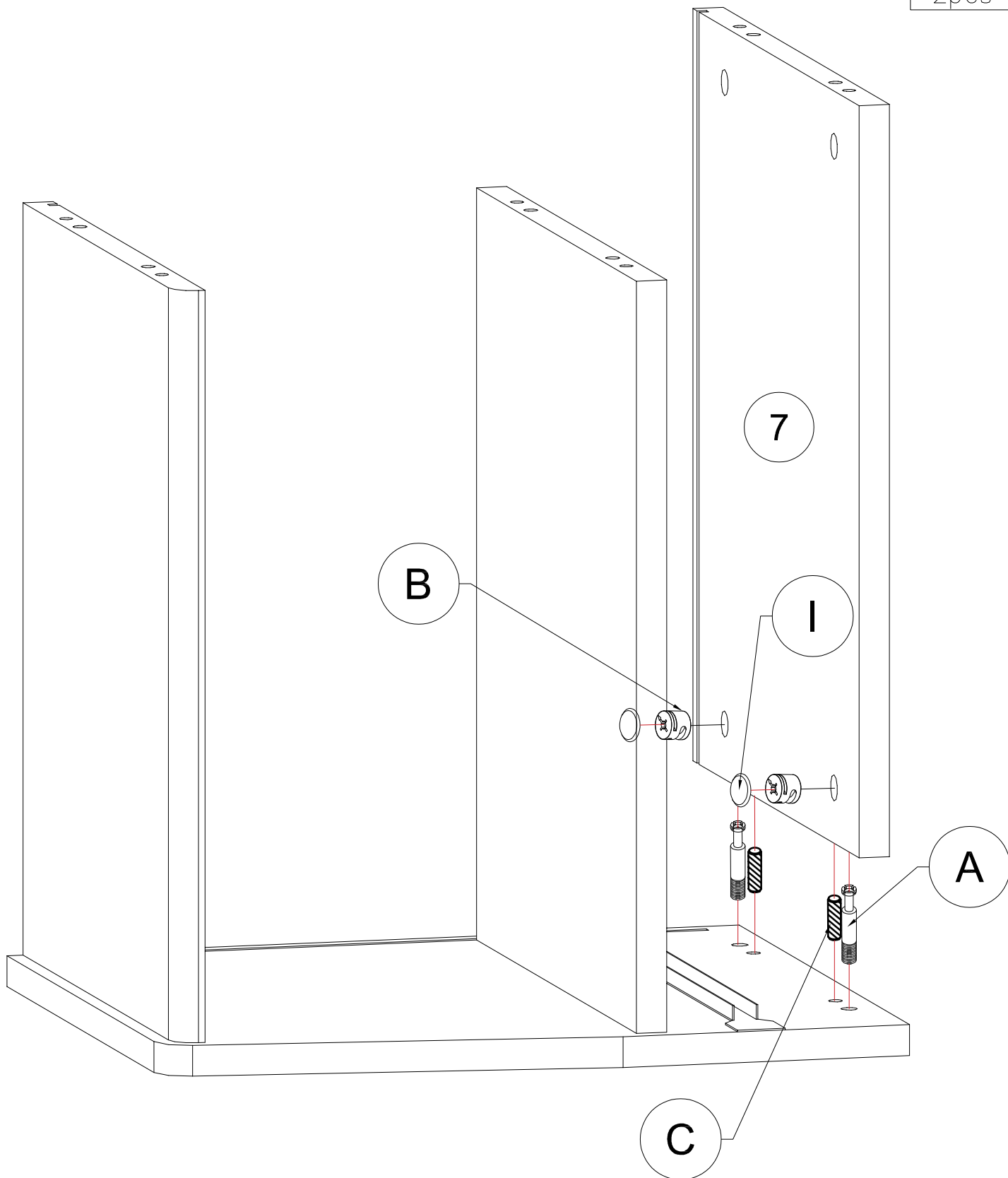

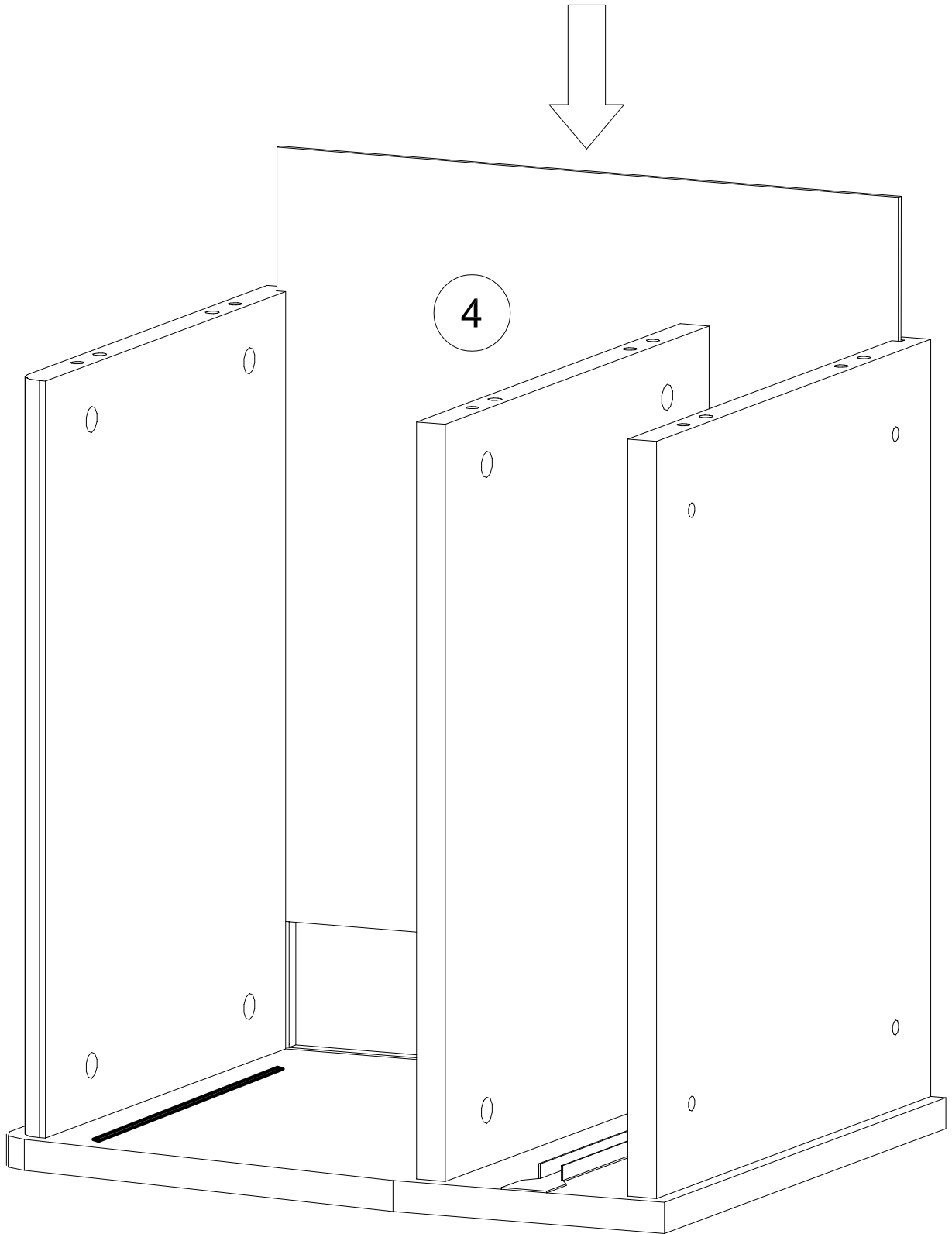

STEP 4: Following below illustration:

ÉTAPE 4 : Suivez l'illustration ci-dessous :



STEP 5: Following below illustration:

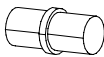

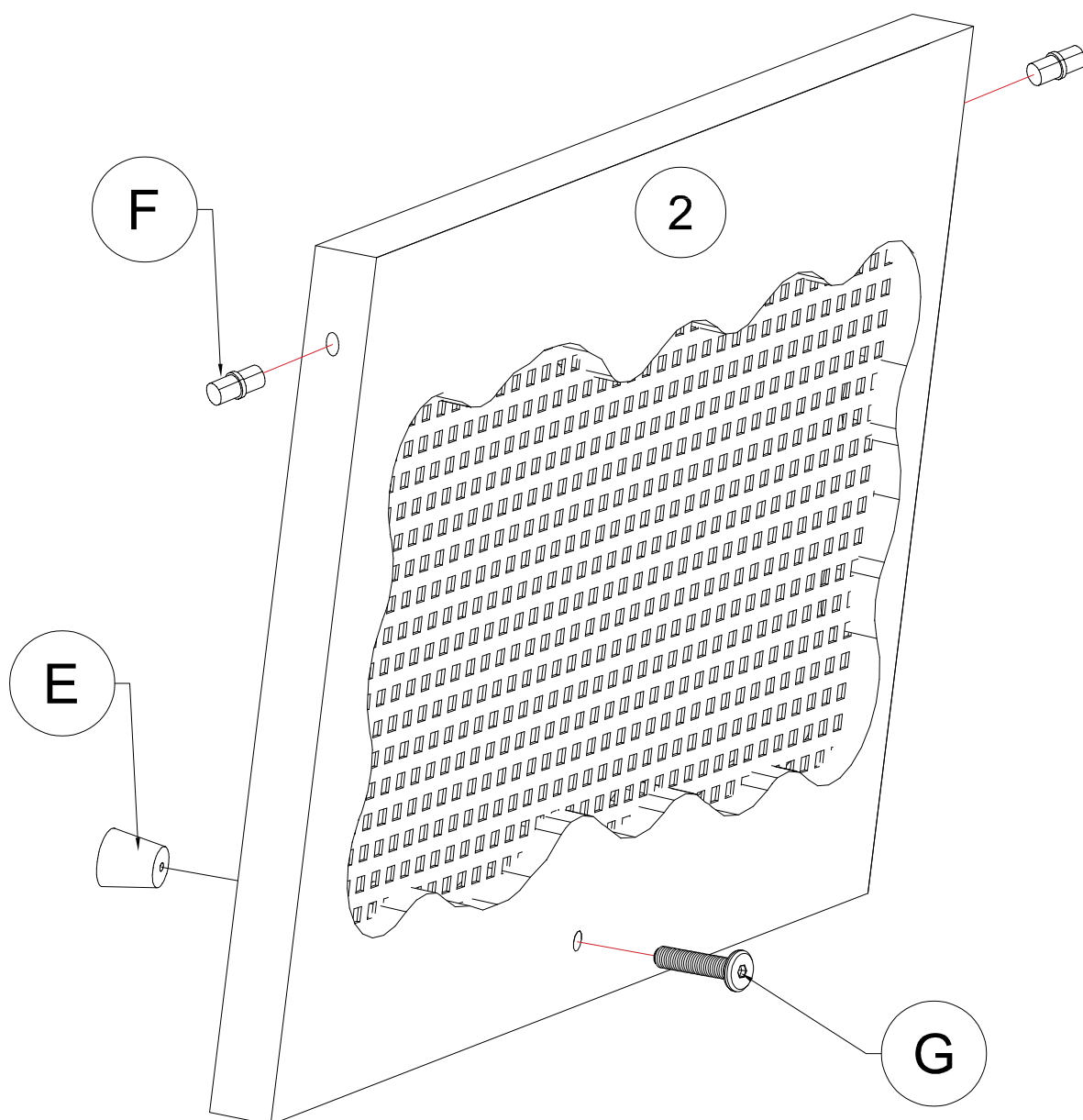

ÉTAPE 5 : Suivez l'illustration ci-dessous :

F	E	G
		
2pcs	1pc	1pc

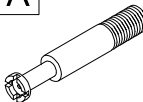

STEP 6: Following below illustration:

ÉTAPE 6 : Suivez l'illustration ci-dessous :

A 	B 	C 
6pcs	6pcs	6pcs
I 		
6pcs		

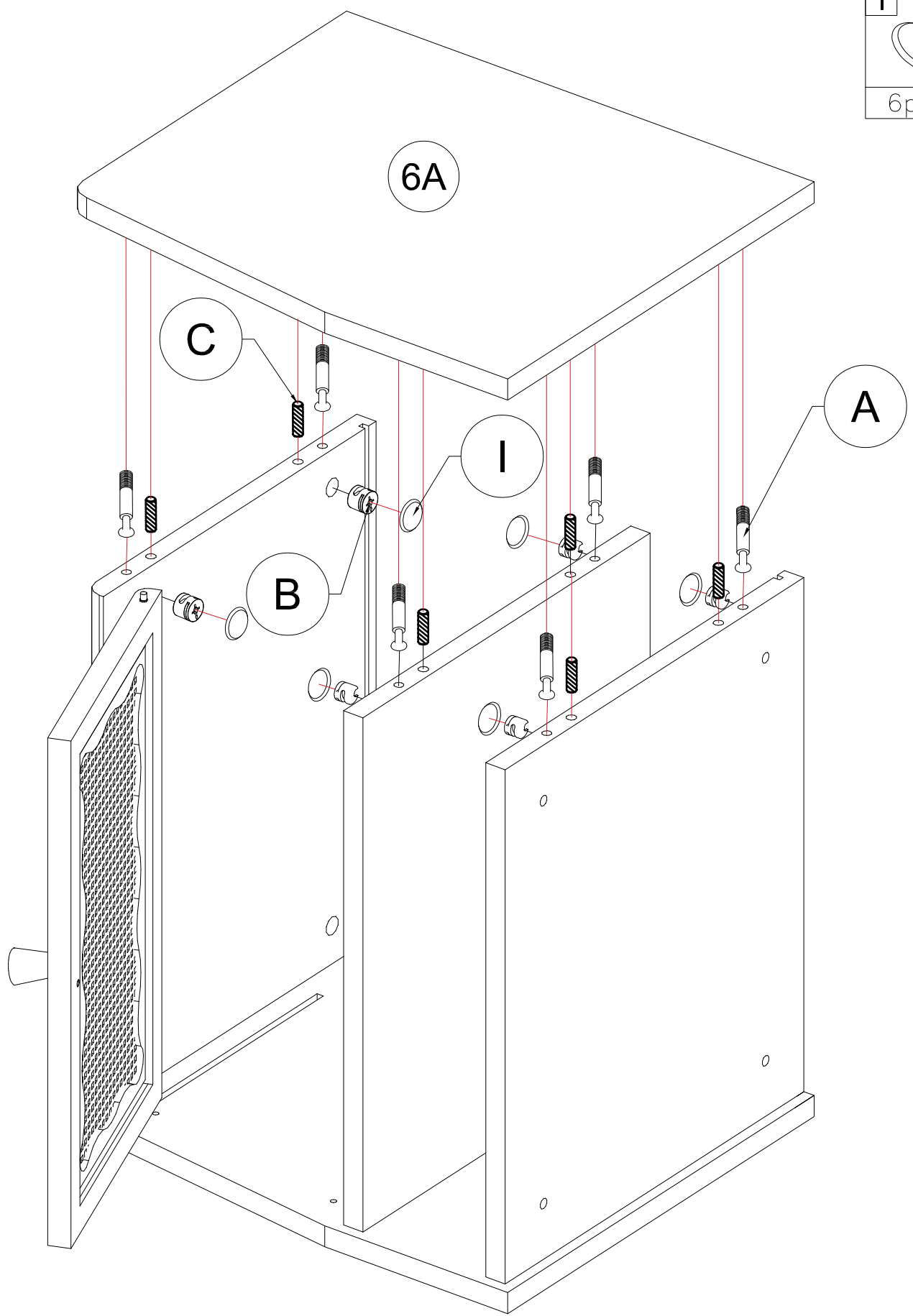

STEP 7: Following below illustration:

ÉTAPE 7 : Suivez l'illustration ci-dessous :

F

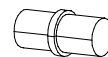

4pcs

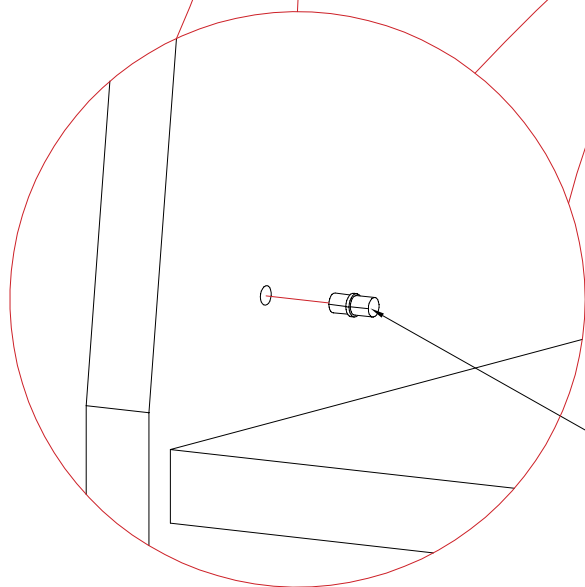
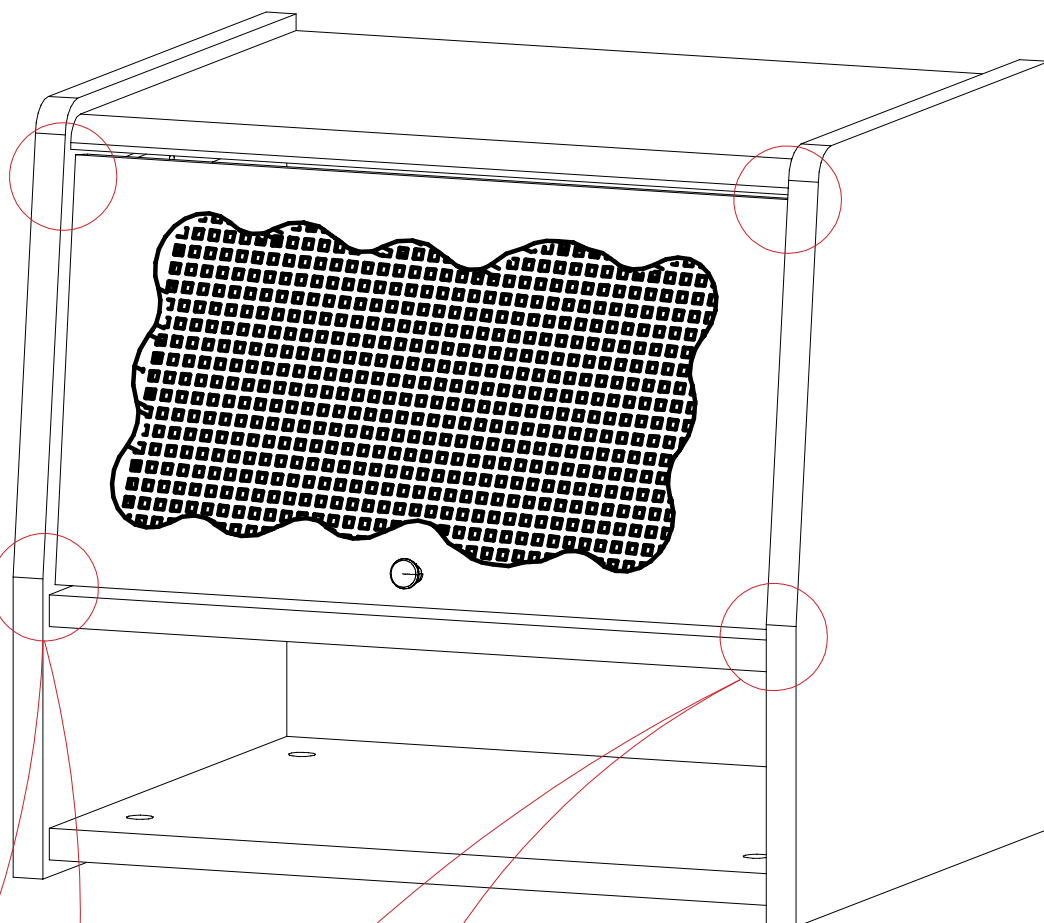

F

STEP 8: Following below illustration:

ÉTAPE 8 : Suivez l'illustration ci-dessous :

H	
4pcs	

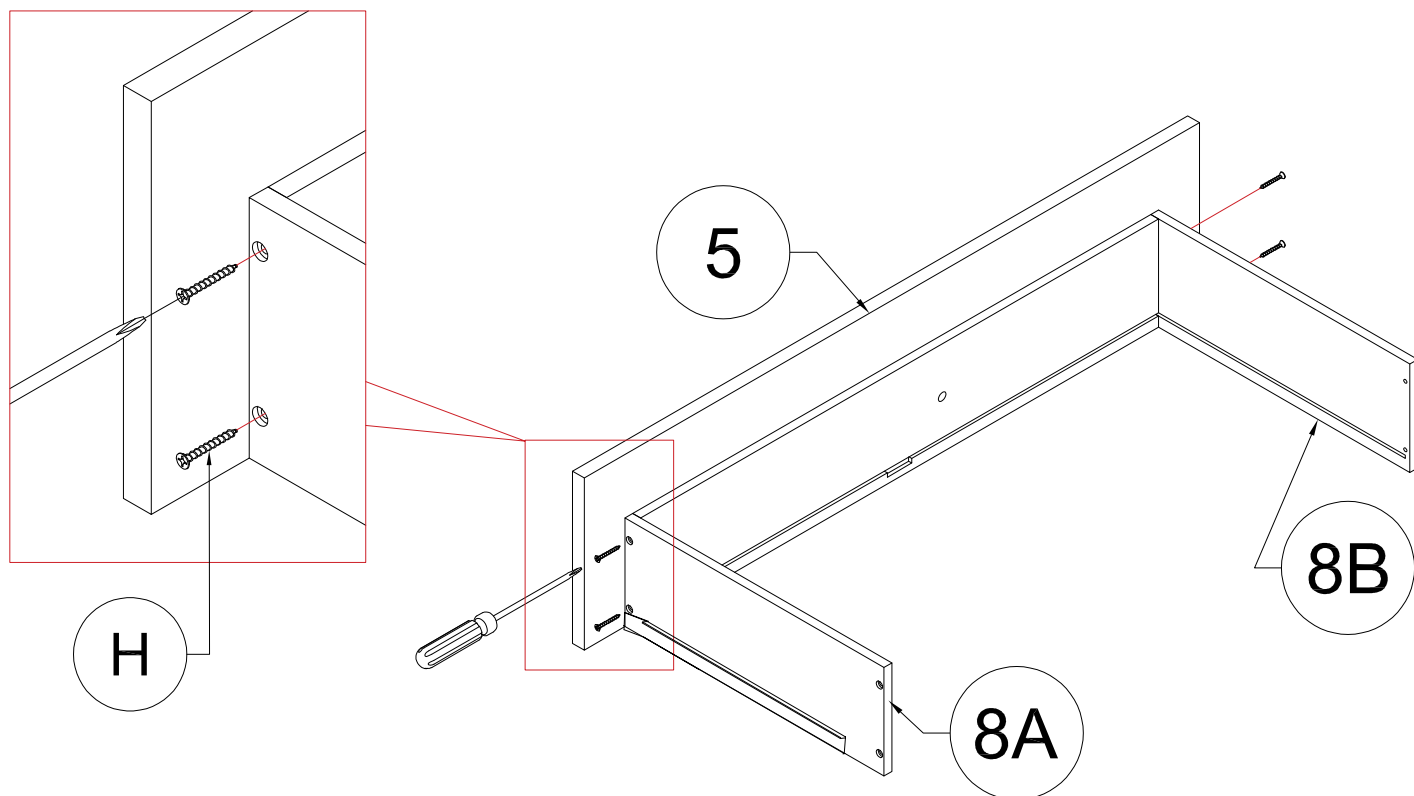

STEP 9: Following below illustration:

ÉTAPE 9 : Suivez l'illustration ci-dessous :

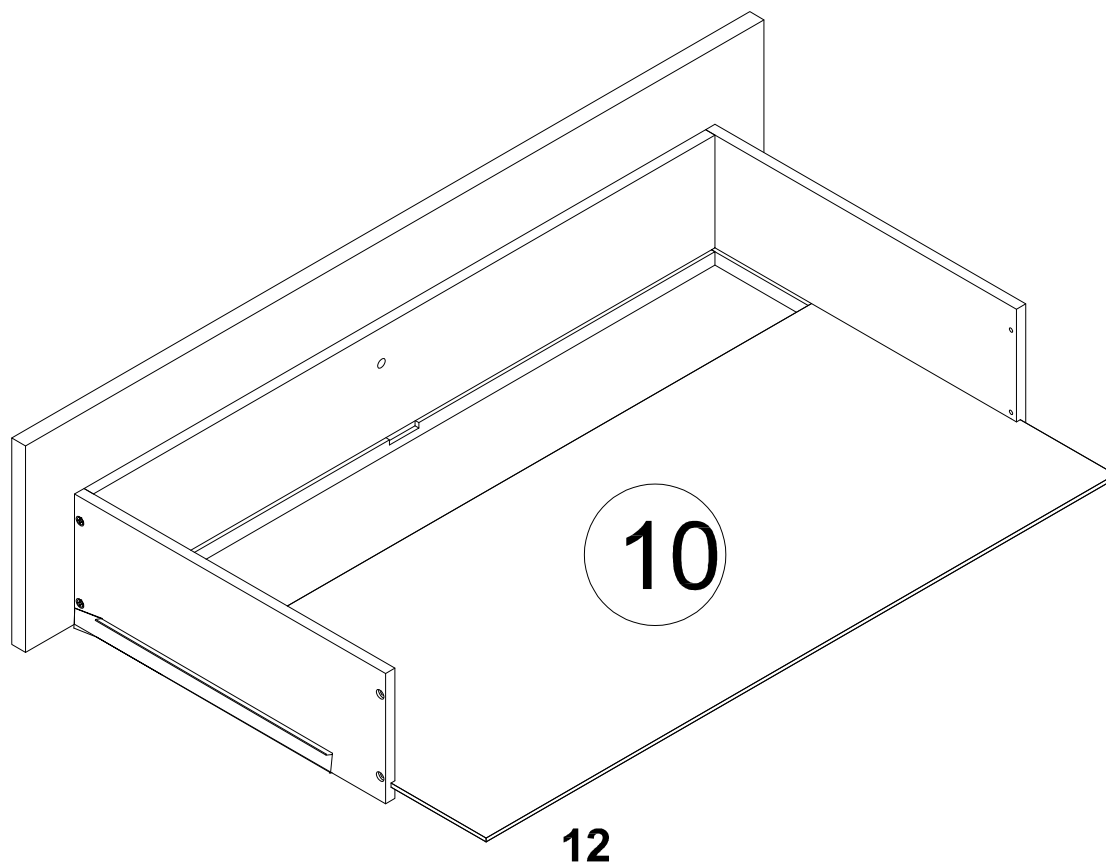

STEP 10: Following below illustration:

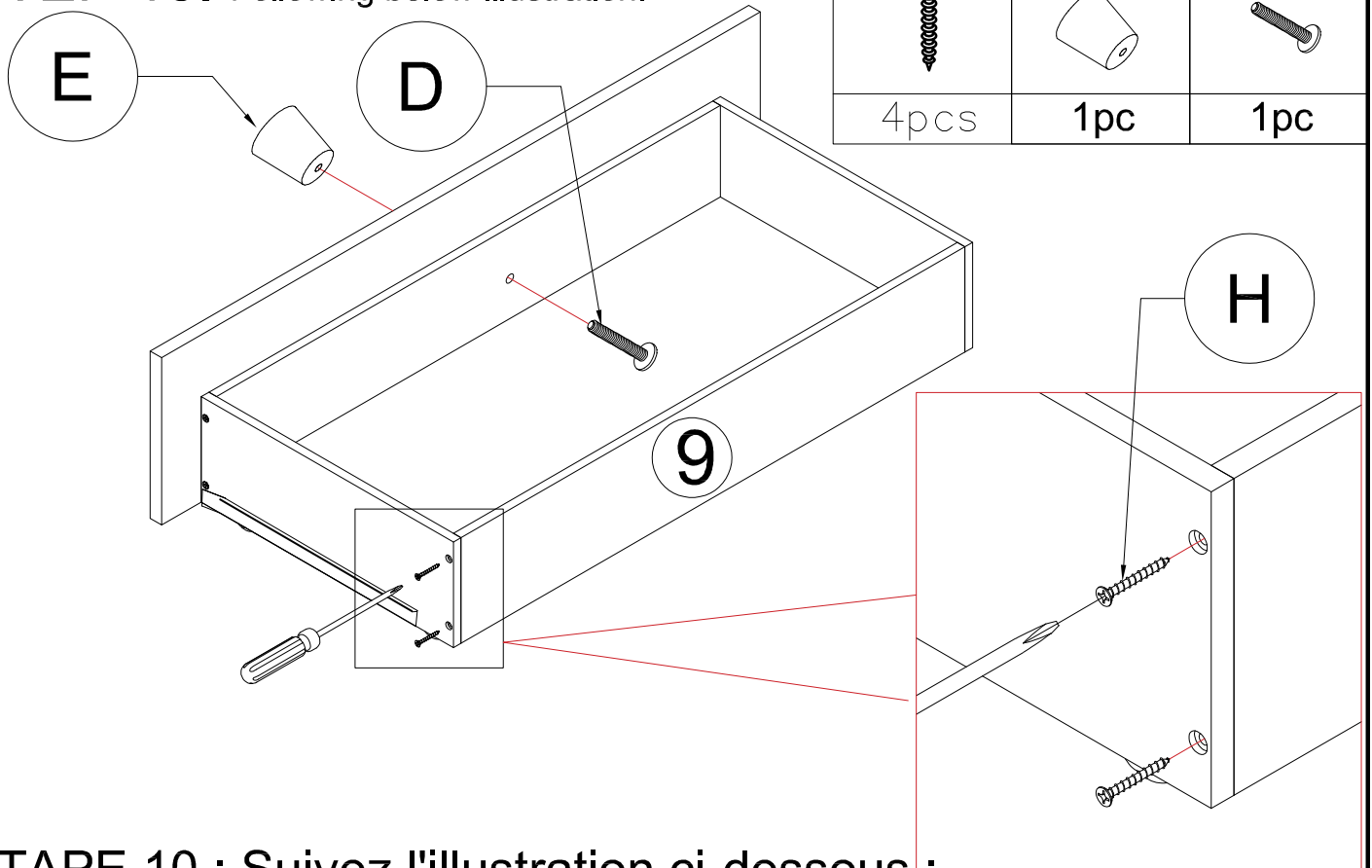

ÉTAPE 10 : Suivez l'illustration ci-dessous :

STEP 11: Following below illustration:

ÉTAPE 11 : Suivez l'illustration ci-dessous :

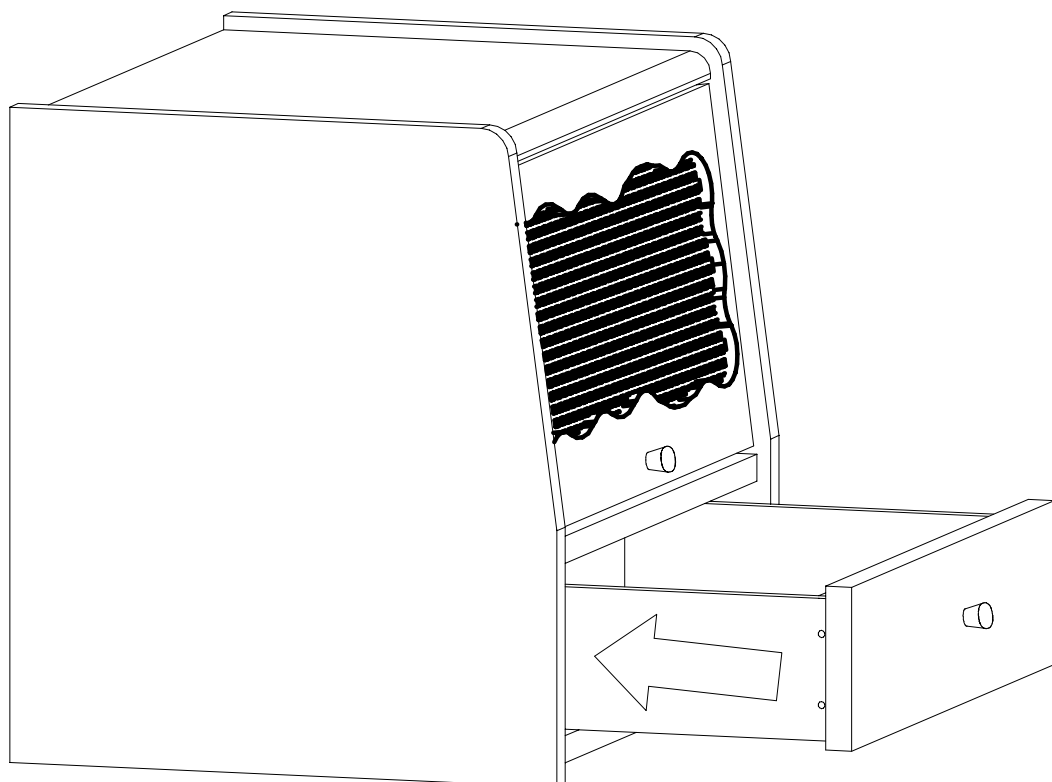

STEP 12: Following below illustration:

ÉTAPE 12 : Suivez l'illustration ci-dessous :

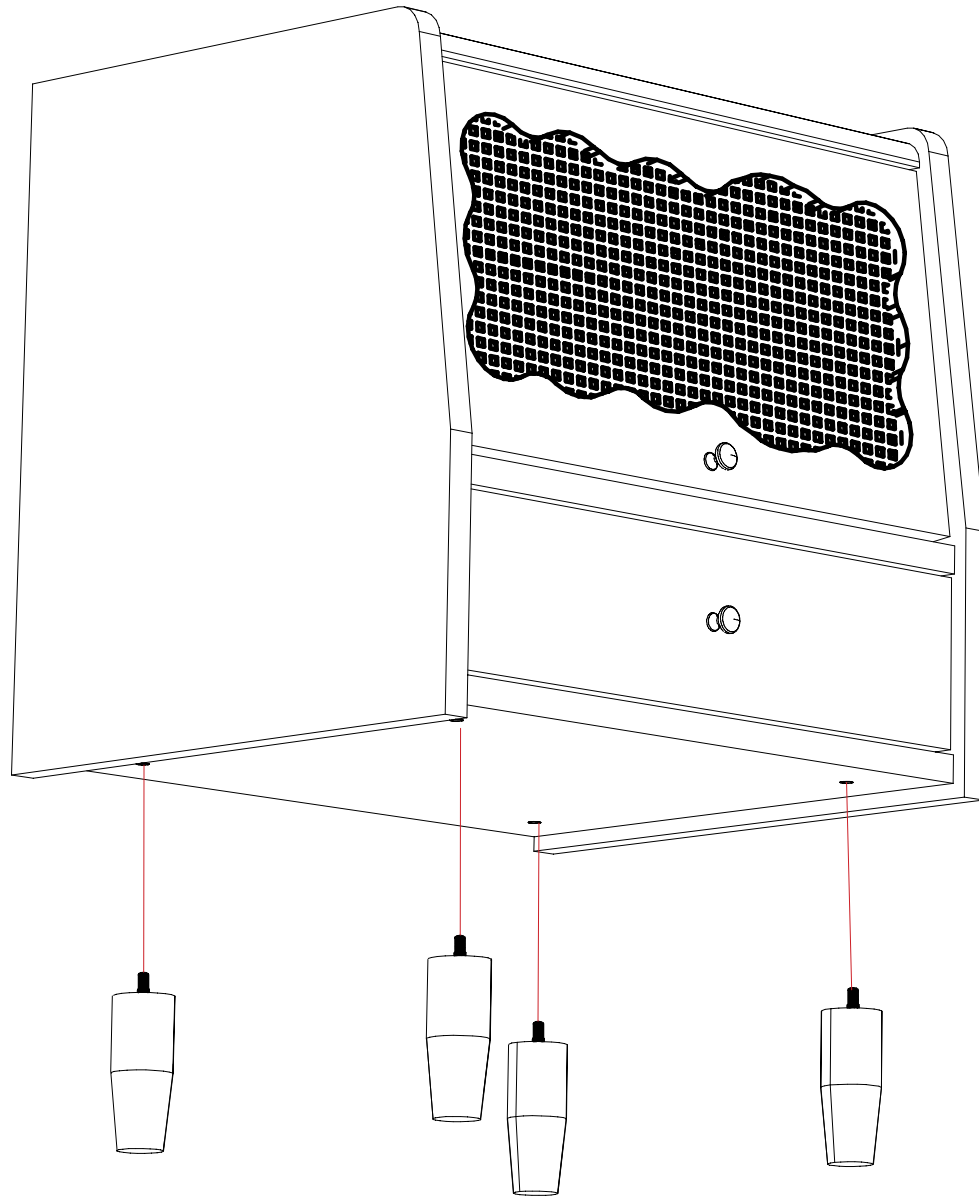

11

14

FINISH

FINITION

