

ASSEMBLY INSTRUCTION

WF320519

REAR

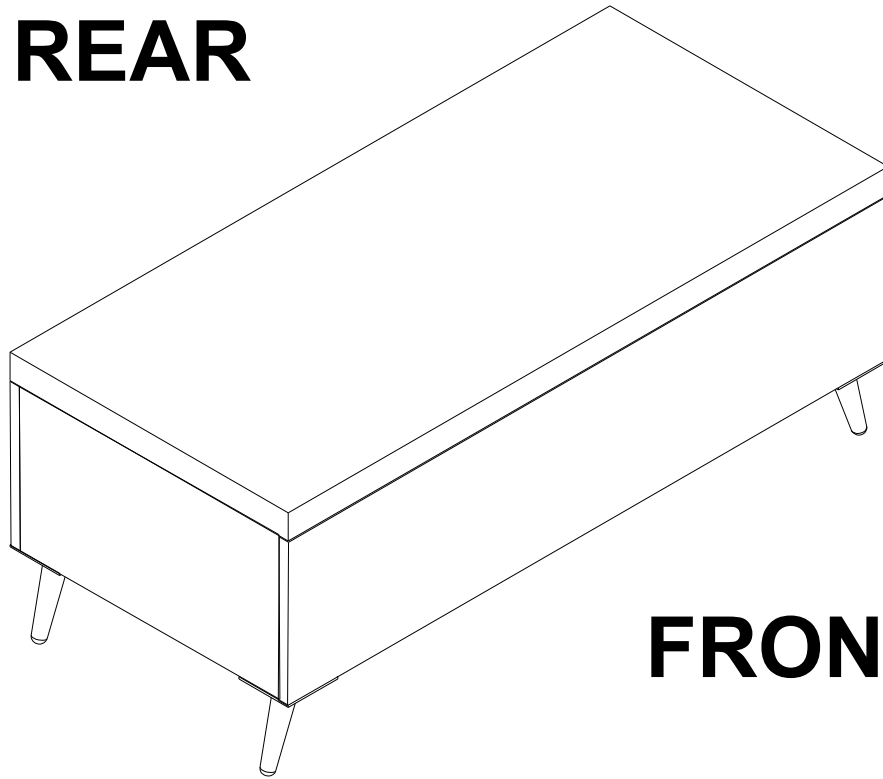

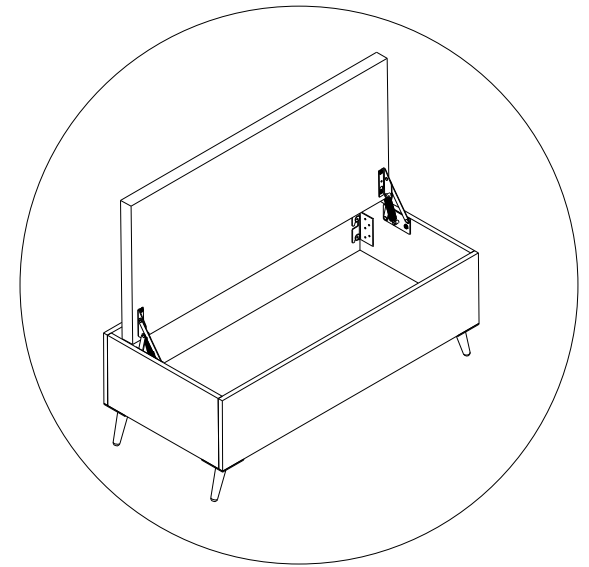

FRONT

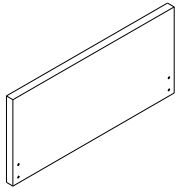
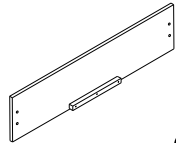
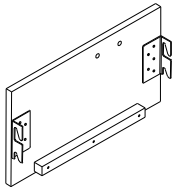
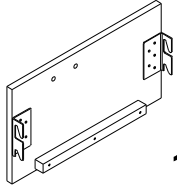
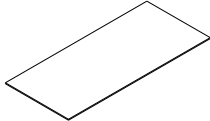

PART LIST

<p>1 Top Panel</p>  <p>1pc</p>	<p>2 Long Panel</p>  <p>2pcs</p>	<p>3-L Short Panel (Left)</p>  <p>1pc</p>	<p>3-R Short Panel (Right)</p>  <p>1pc</p>	<p>4 Base Panel</p>  <p>1pc</p>
--	--	---	--	---

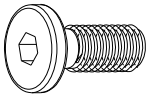
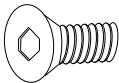
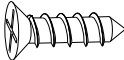
HARDWARE LIST

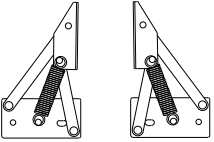
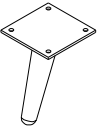
<p>A M8*16MM JCBB</p>  <p>8pcs</p>	<p>B JCBC M6*15MM</p>  <p>8pcs</p>	<p>C SCREW M3.5*16MM</p>  <p>12pcs</p>	<p>D ALLEN KEY M5</p>  <p>1pc</p>	<p>E ALLEN KEY M4</p>  <p>1pc</p>
<p>F HINGE</p>  <p>L-1pc/R-1pc</p>	<p>G LEG</p>  <p>4pcs</p>			

STEP 1

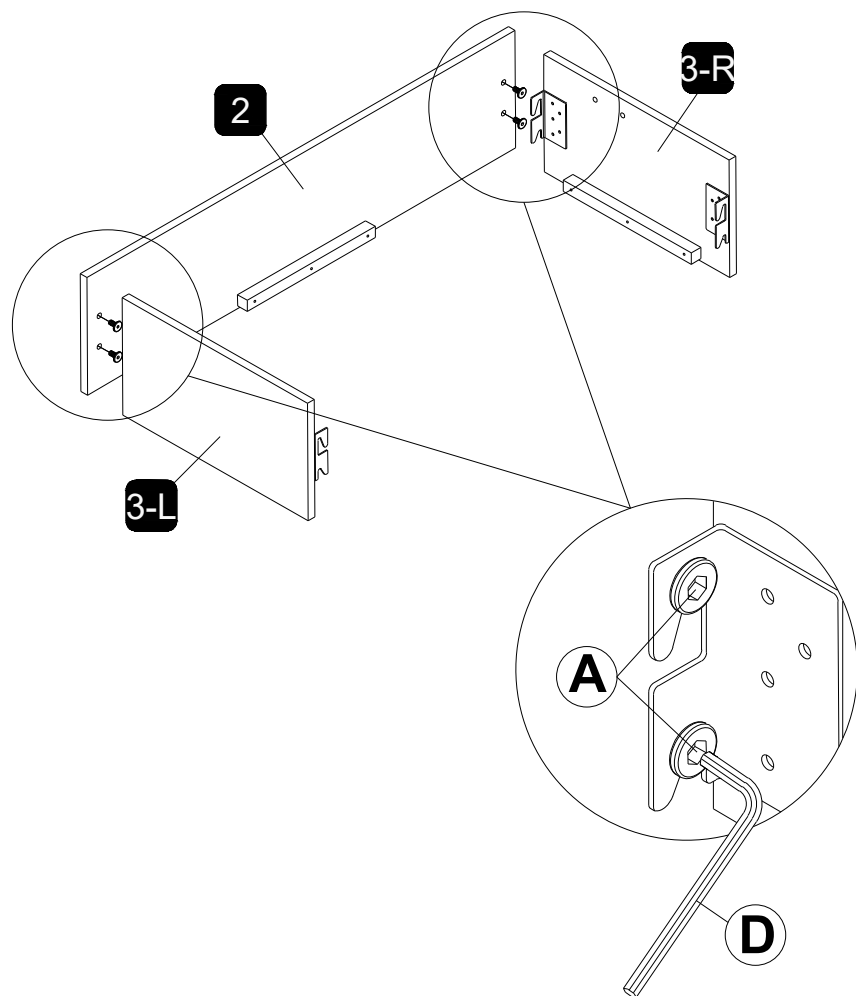



A X 4pcs

D X 1pc

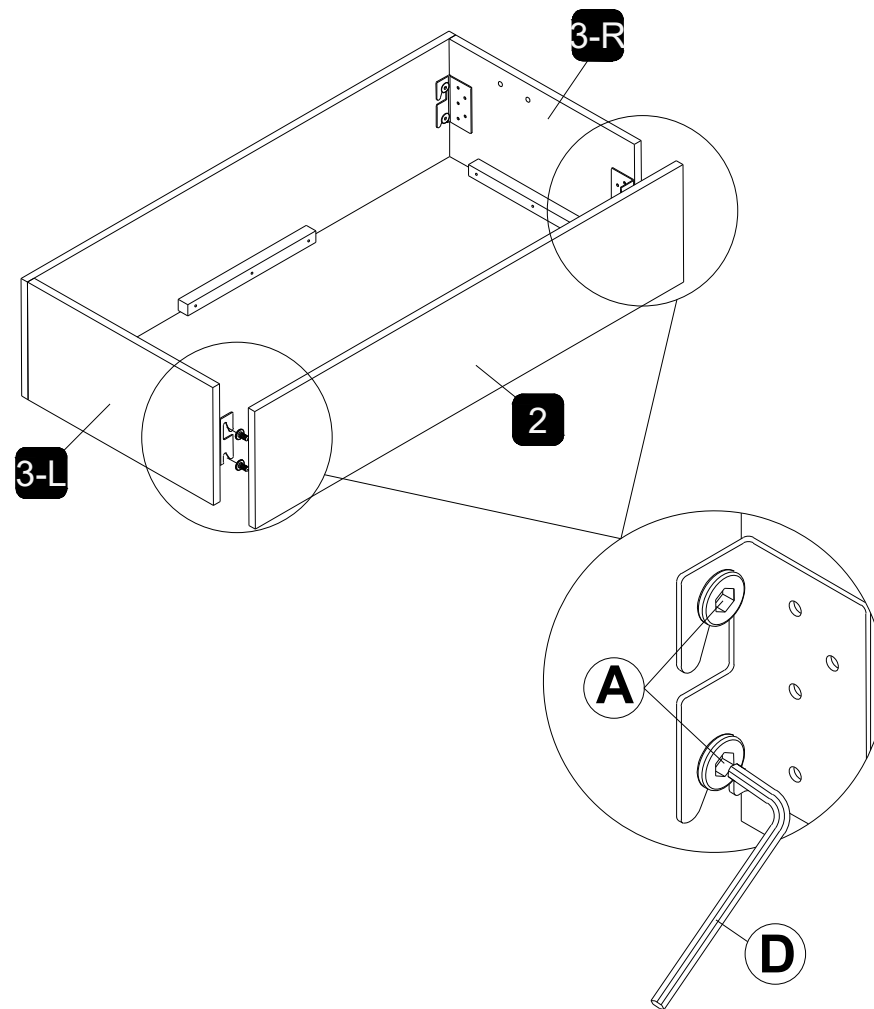
STEP 2



A X 4pcs

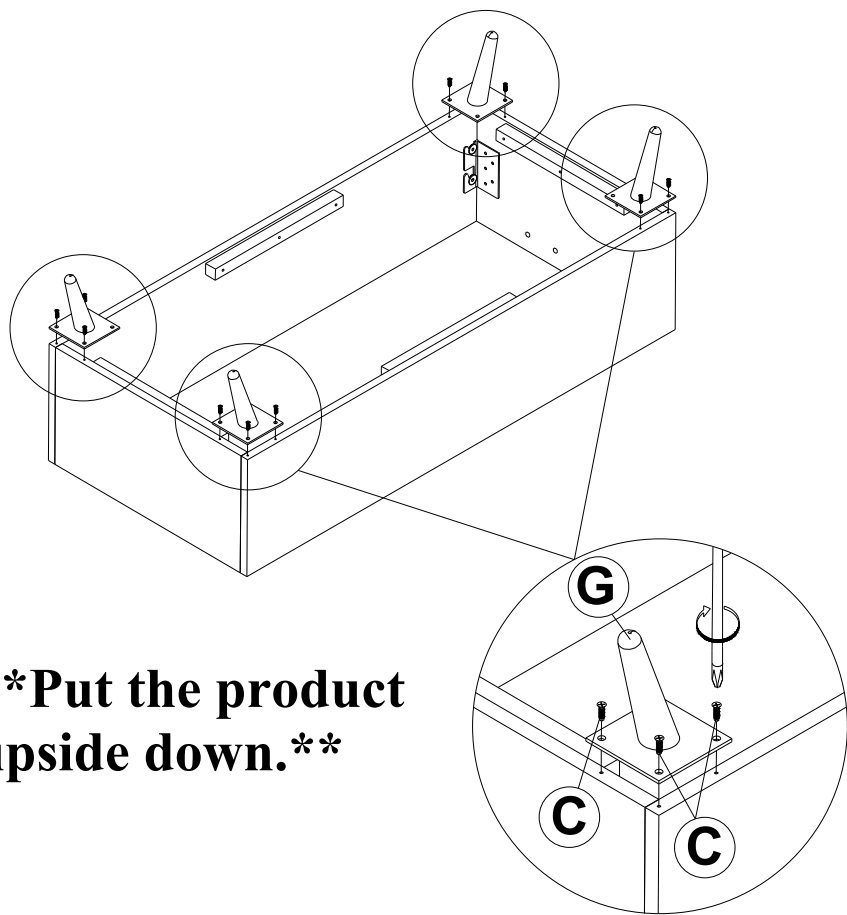

D X 1pc

STEP 3

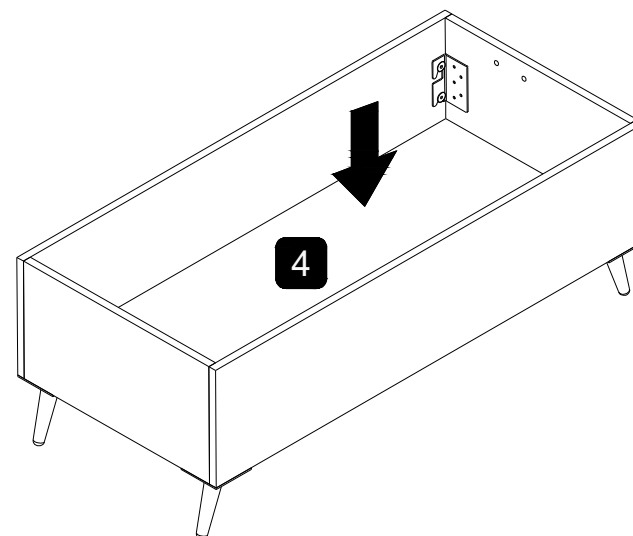

****Put the product upside down.****

STEP 4





C X 12pcs

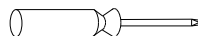

G X 4pcs

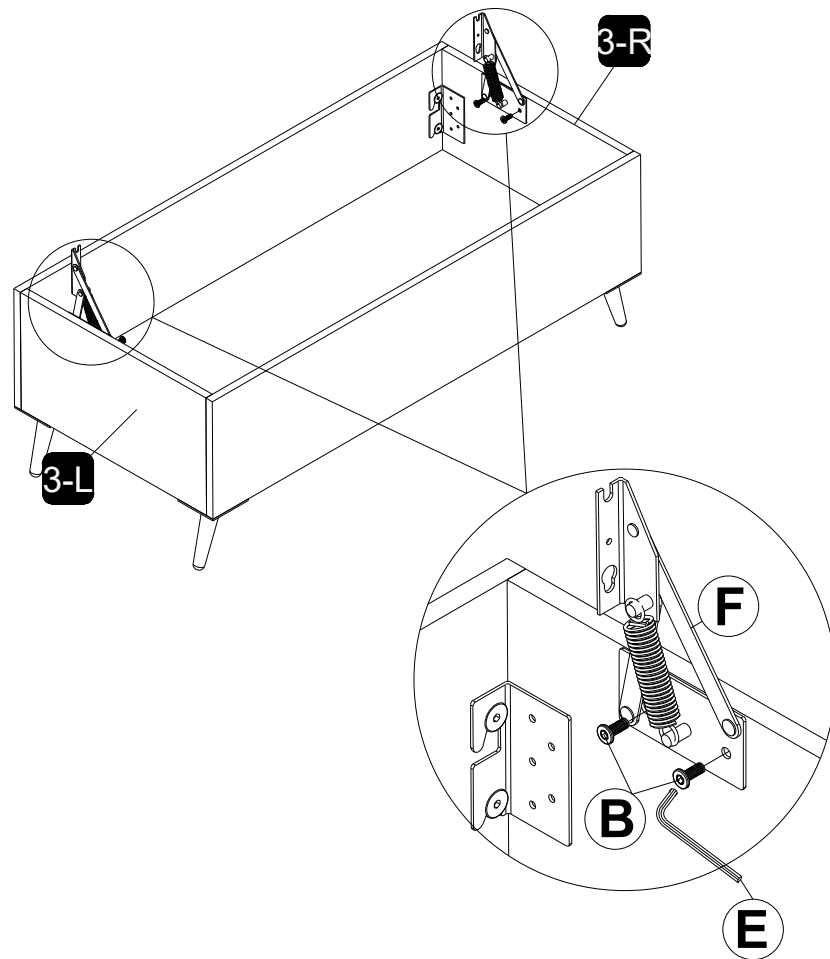

STEP 5





B X 4pcs

E X 1pc

F X L-1/R-1

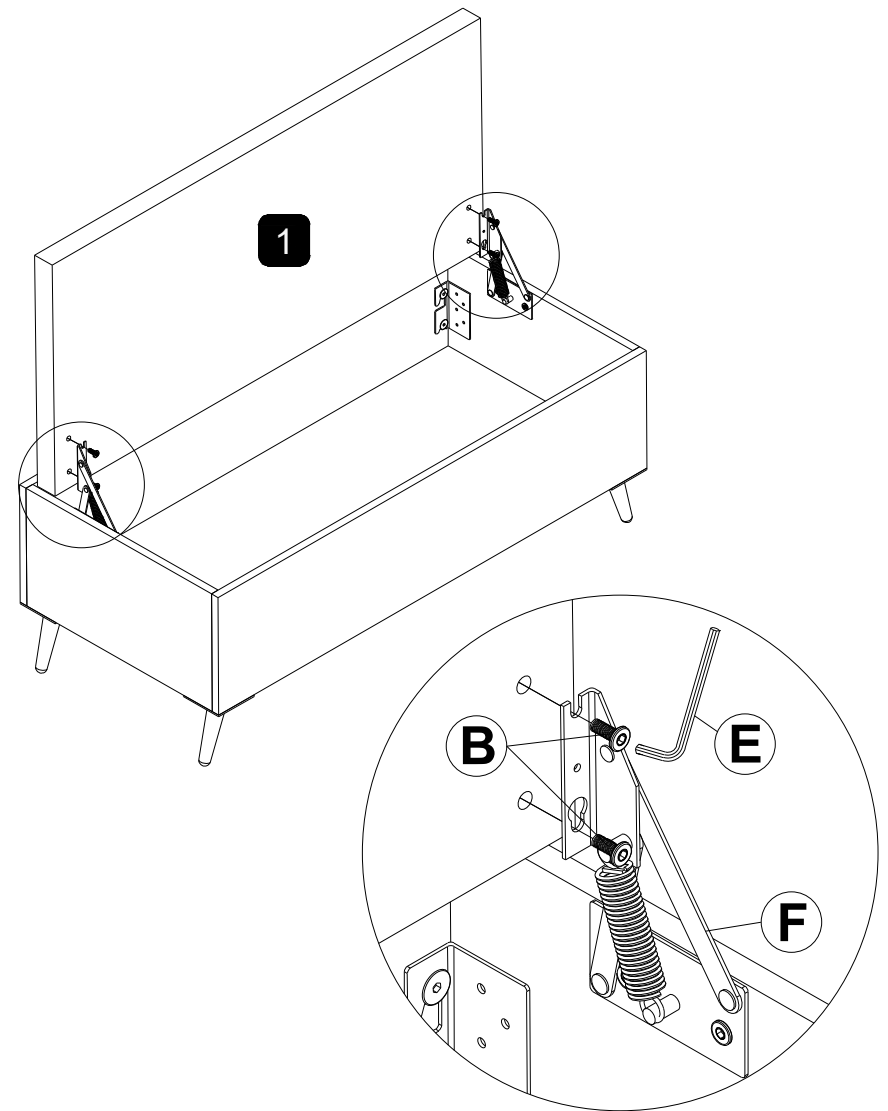
STEP 6



B X 4pcs

E X 1pc

COMPLETED ASSEMBLY

