

ASSEMBLY INSTRUCTION

SKU : N733P185867

INSTRUCTIONS DE MONTAGE

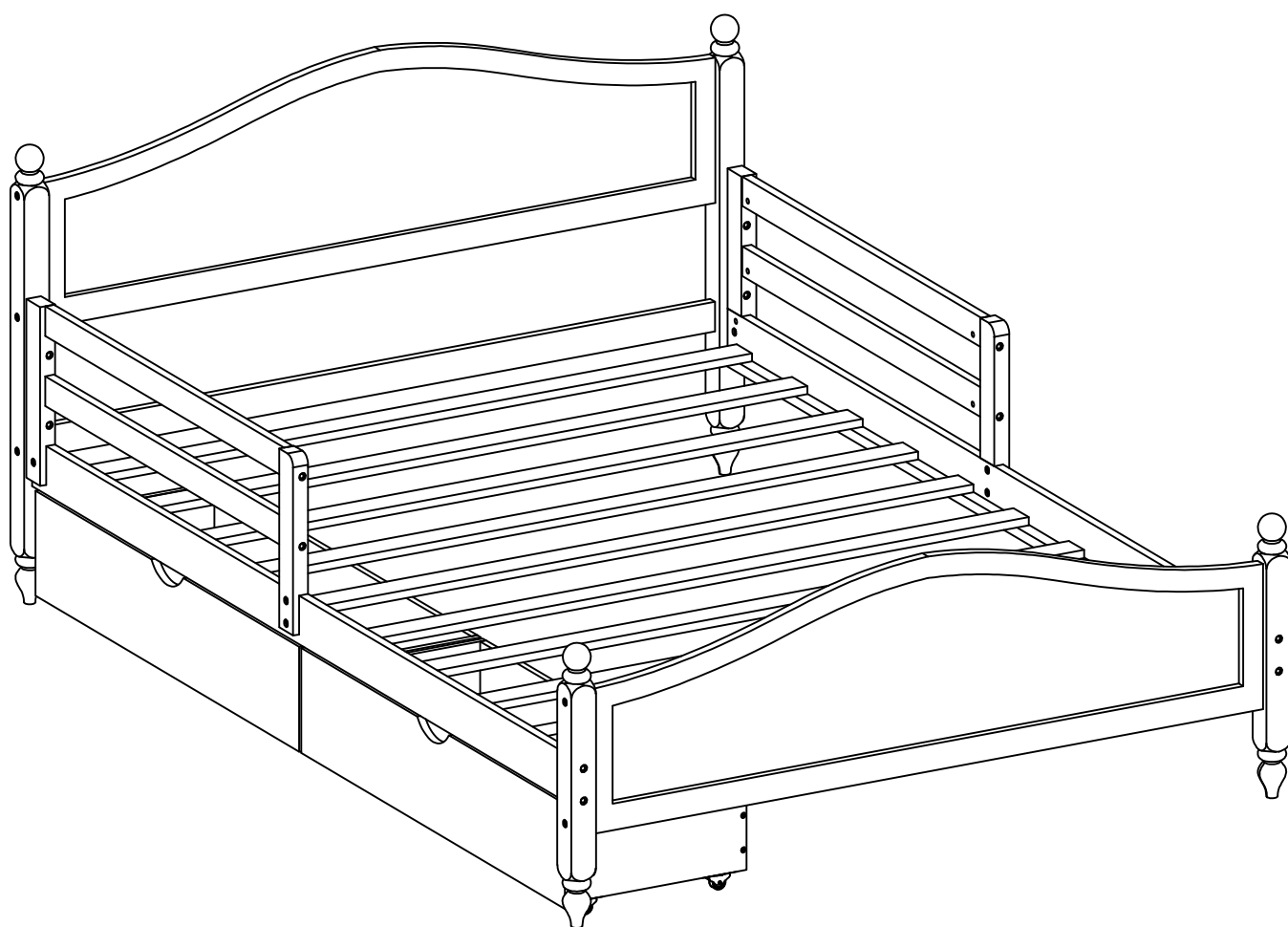



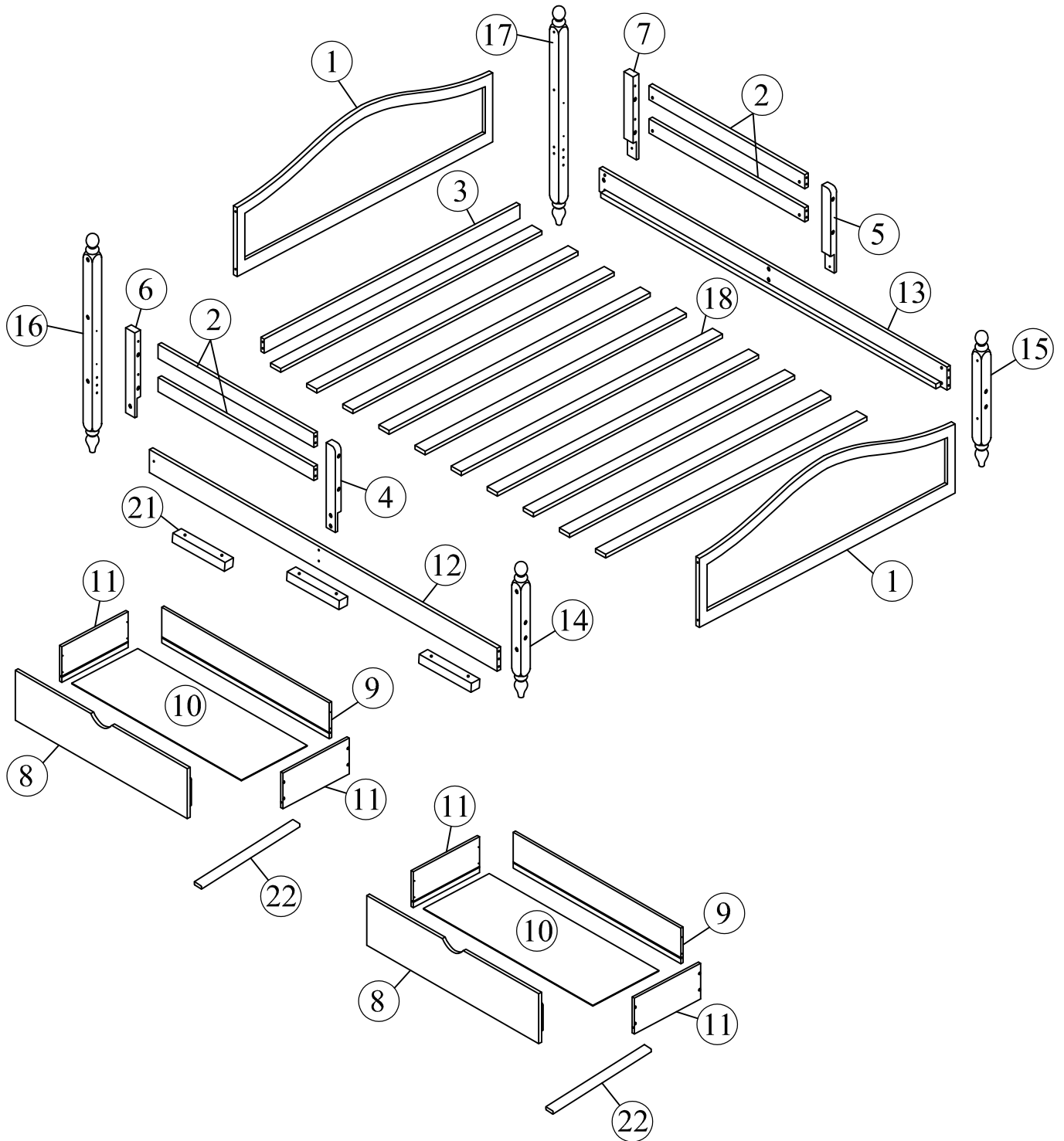

UGS : N733P185867

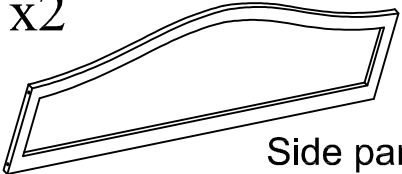
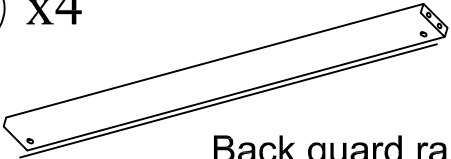

Detail:
Détail:

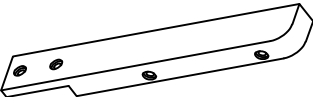

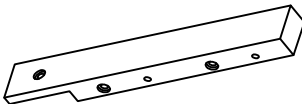
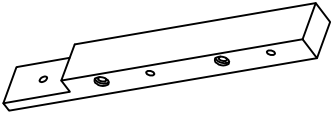
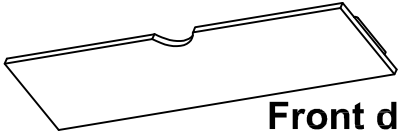
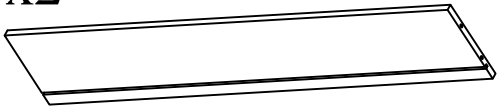
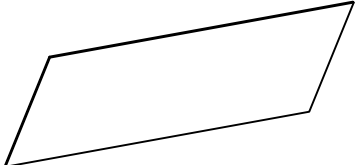
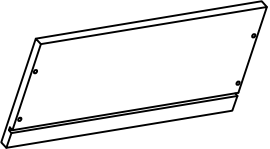
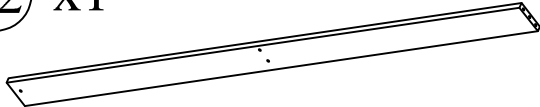
Part List / Liste des pièces

<p>① x2</p>  <p>Side panel Panneau latéral</p>	<p>② x4</p>  <p>Back guard rail Garde-corps arrière</p>
<p>③ x1</p>  <p>Left bottom side rail Rail latéral inférieur gauche</p>	<p>④ x1</p>  <p>Right front wood bar Barre en bois avant droite</p>
<p>⑤ x1</p>  <p>Right back wood bar Barre en bois arrière droite</p>	<p>⑥ x1</p>  <p>Left front wood bar Barre en bois avant gauche</p>
<p>⑦ x1</p>  <p>Left back wood bar Barre en bois arrière gauche</p>	<p>⑧ x2</p>  <p>Front drawer Tiroir avant</p>
<p>⑨ x2</p>  <p>Back panel of drawer Panneau arrière du tiroir</p>	<p>⑩ x2</p>  <p>Bottom panel of drawer Panneau inférieur du tiroir</p>
<p>⑪ x4</p>  <p>Side panel of drawer Panneau latéral du tiroir</p>	<p>⑫ x1</p>  <p>Front side rail Rail latéral avant</p>
<p>⑬ x1</p>  <p>Back side rail Rail latéral arrière</p>	<p>⑭ x1</p>  <p>Right front leg Jambe avant droite</p>

Part List / Liste des pièces

15 x1

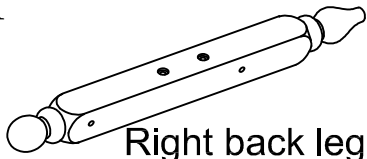

Right back leg
Jambe arrière droite

16 x1

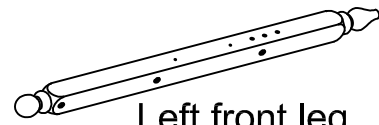

Left front leg
Jambe avant gauche

17 x1



Left back leg
Jambe arrière gauche

18 x10



Slat
Latte

21 x3

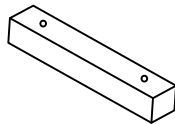





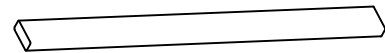







Bottom wood bar
Barre inférieure en bois

22 x2



Right bottom side rail
Rail latéral inférieur droit

Hardware List / Liste du matériel

No/Non	OUTLOOK/PERSPECTIVES	DESC/DESC	QTY/QTÉ
(A)		Dowel Ø8*30mm Cheville Ø8*30mm	14pcs 14pièces
(B)		Bolts M6*80mm Boulons M6*80mm	8pcs 8pièces
(C)		Bolts M6*90mm Boulons M6*90mm	18pcs 18pièces
(D)		Bolts M6*20mm Boulons M6*20mm	6pcs 6pièces
(E)		Bolts M6*70mm Boulons M6*70mm	4pcs 4pièces
(F)		Bolts M6*15mm Boulons M6*15mm	6pcs 6pièces
(G)		Cross dowel Ø10*10mm Cheville croisée Ø10*10mm	8pcs 8pièces
(H)		Flat head screw #8*50mm Vis à tête plate #8*50mm	8pcs 8pièces
(I)		Flat head screw #8*25mm Vis à tête plate #8*25mm	32pcs 32pièces
(K)		Allen key 60*22*4mm Clé Allen 60*22*4mm	1pc 1pièces
(L)		Wheels roues	8pcs 8pièces
(M)		Flat head screw #8*30mm Vis à tête plate #8*30mm	20pcs 20pièces

ASSEMBLY TOOLS REQUIRED (NOT INCLUDED)/OUTILS D'ASSEMBLAGE REQUIS (NON INCLUS)



STEP 1:
ÉTAPE 1:

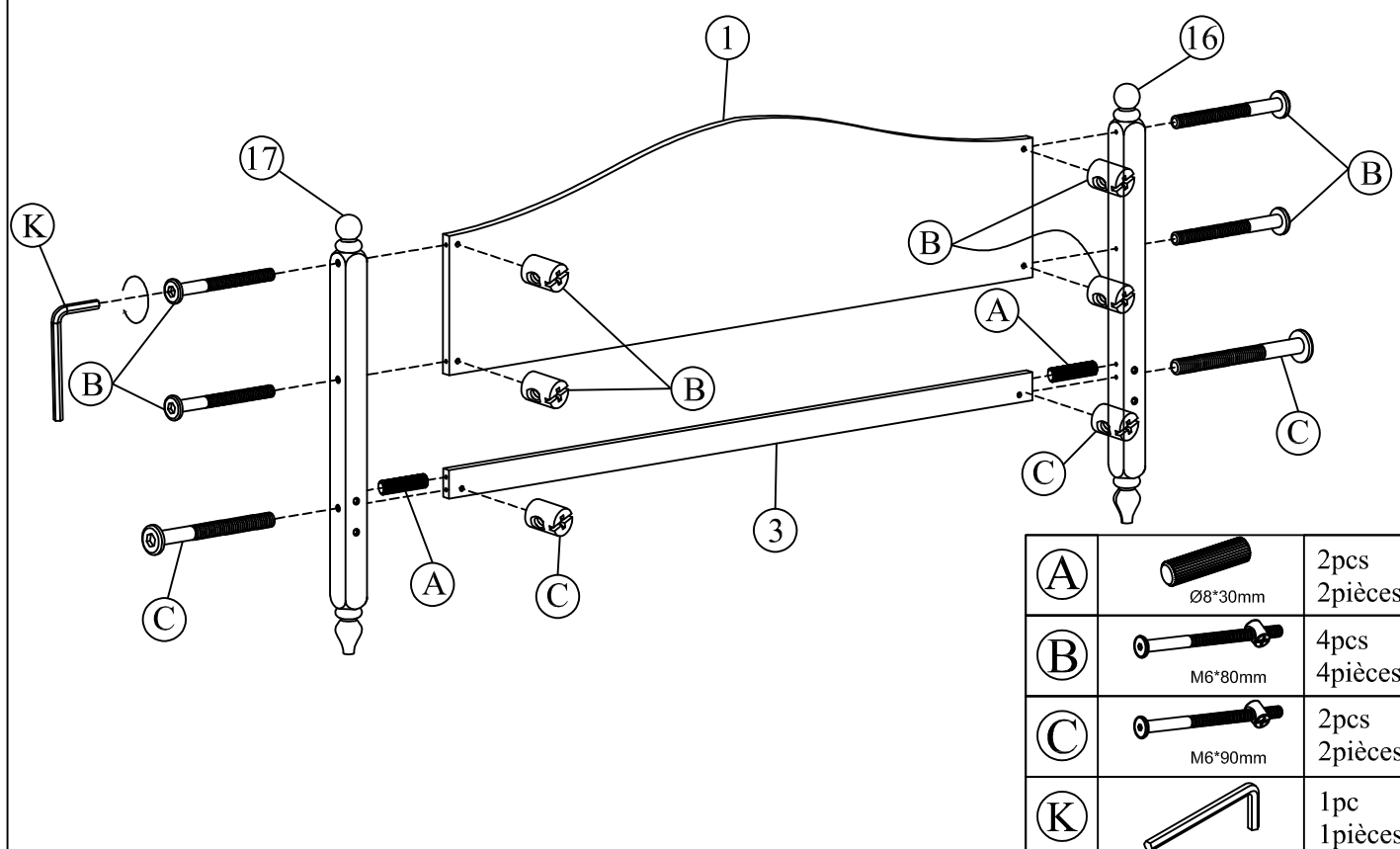

STEP 2:
ÉTAPE 2:

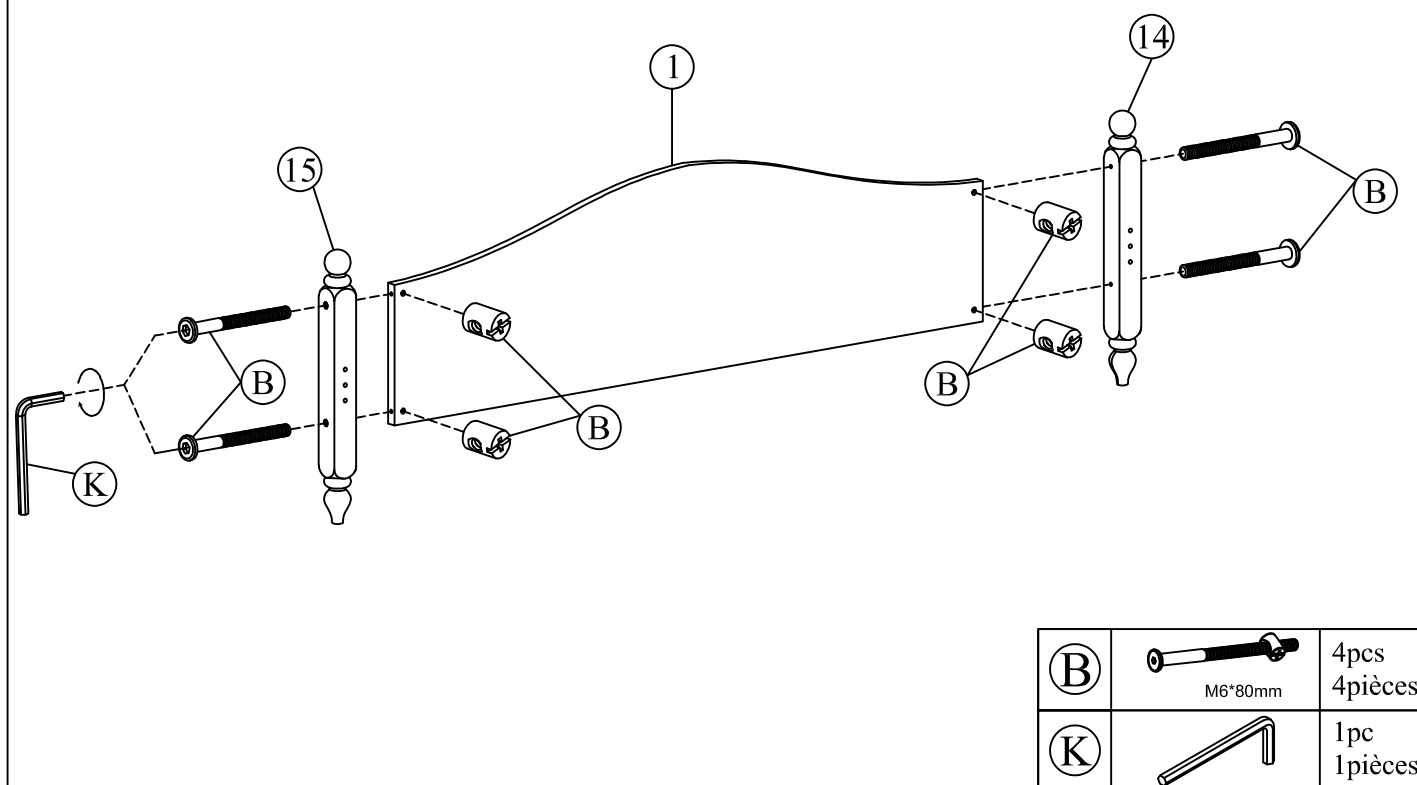

STEP 3:
ÉTAPE 3:

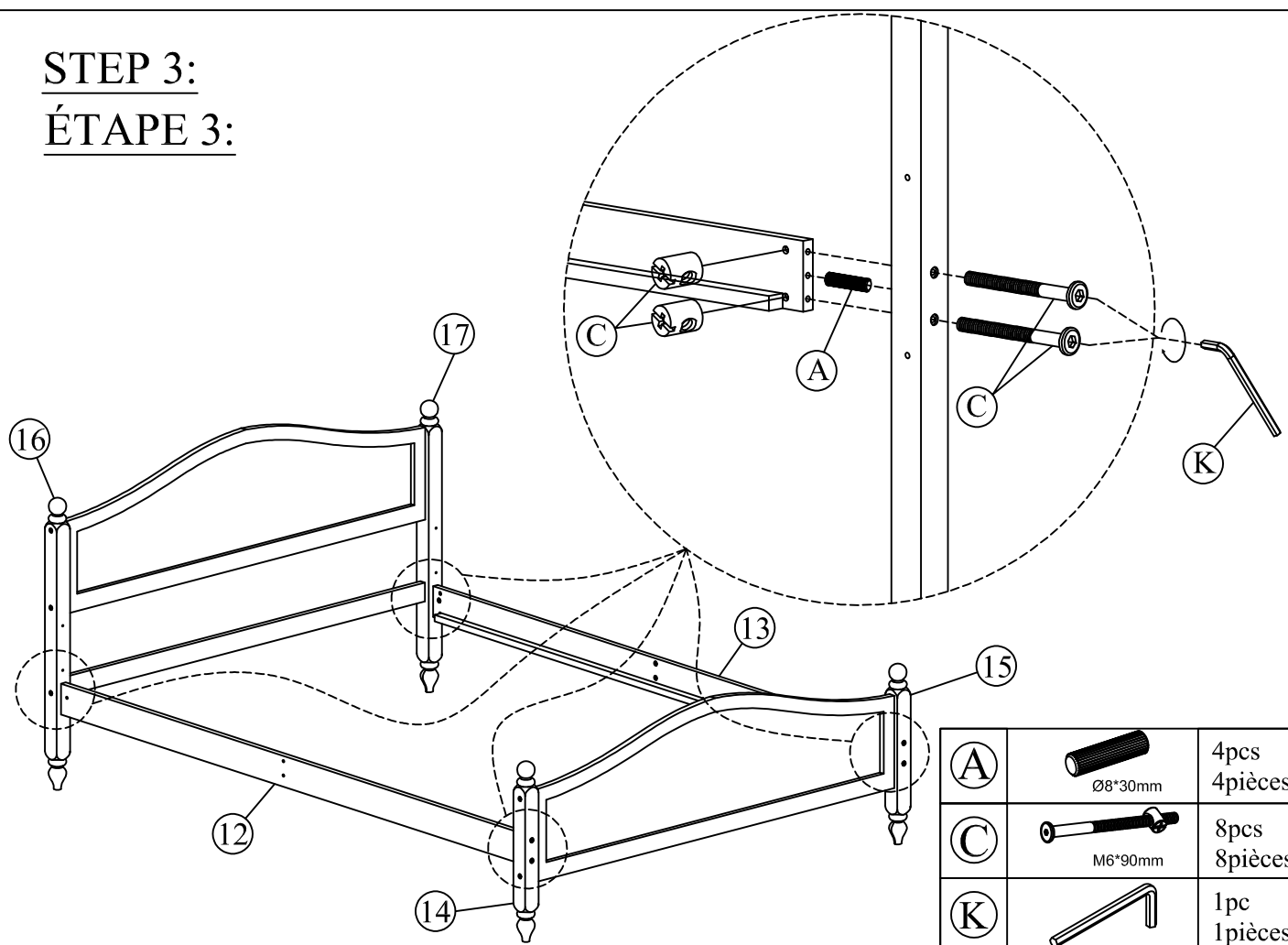

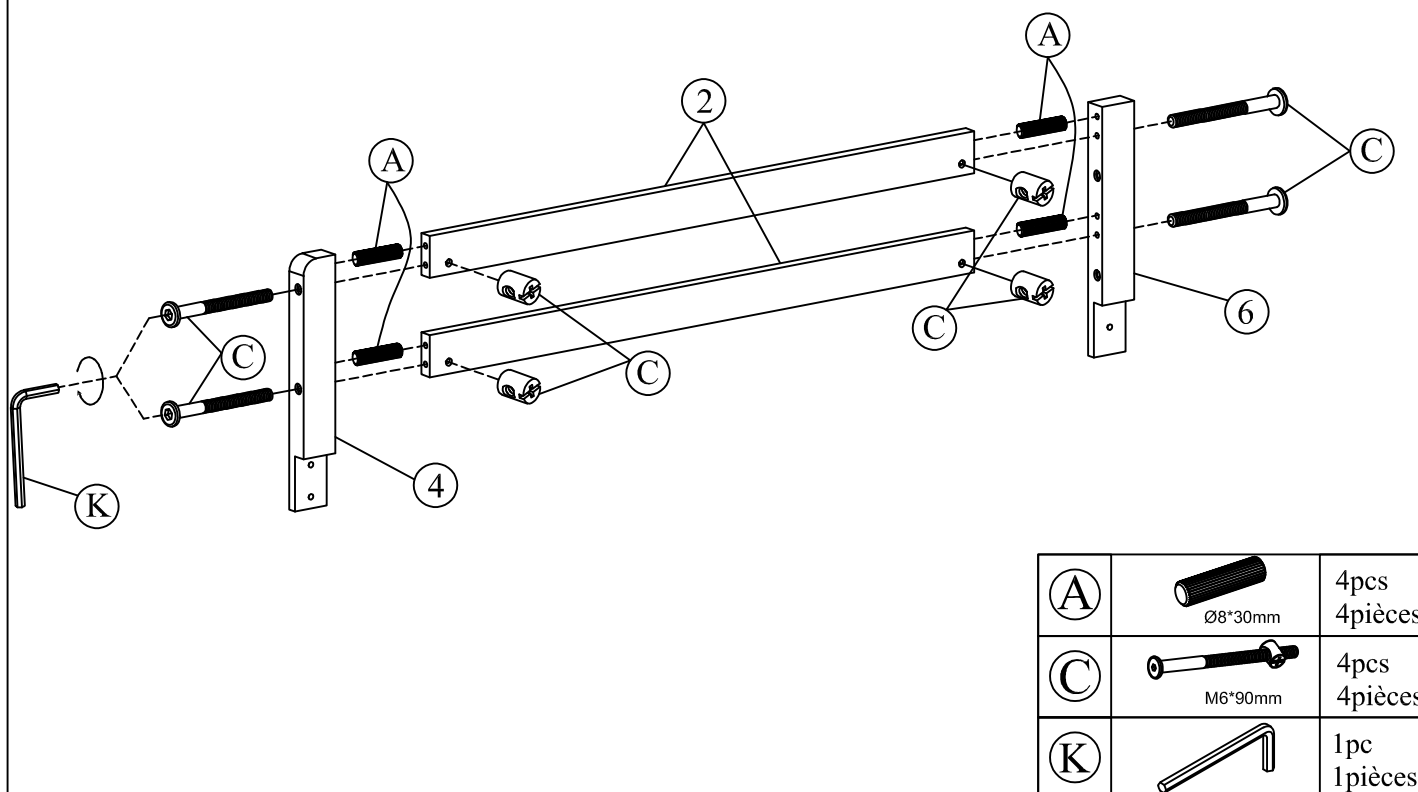

STEP 4:
ÉTAPE 4:



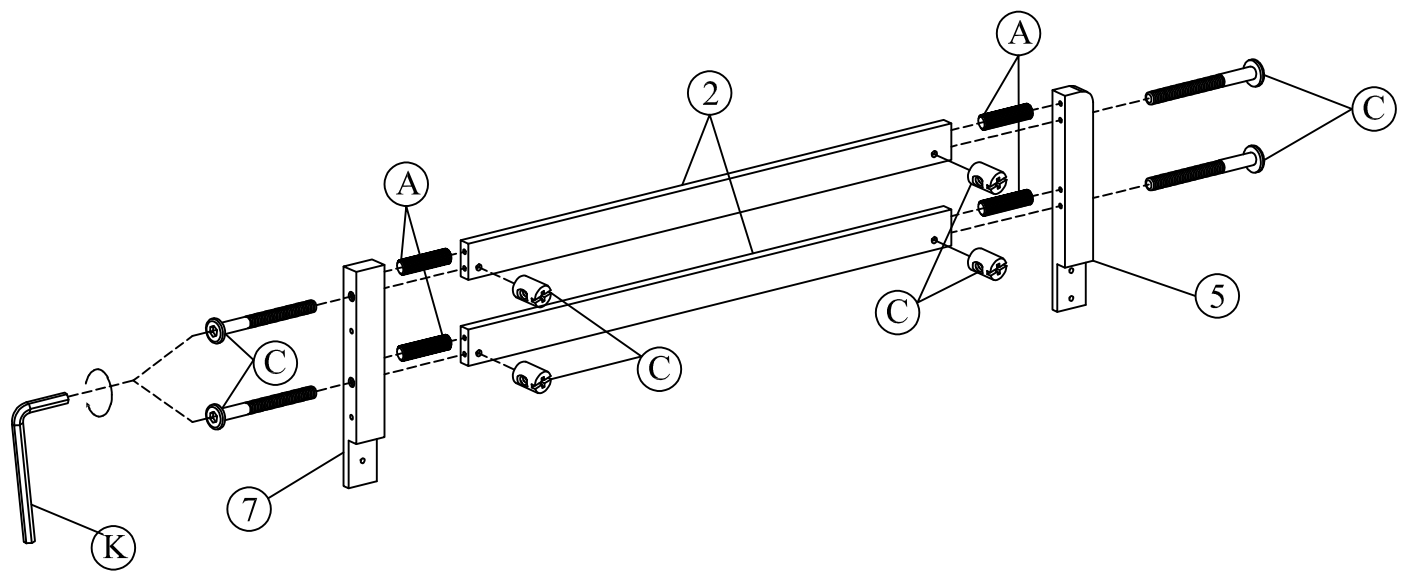

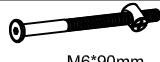

STEP 5:
ÉTAPE 5:

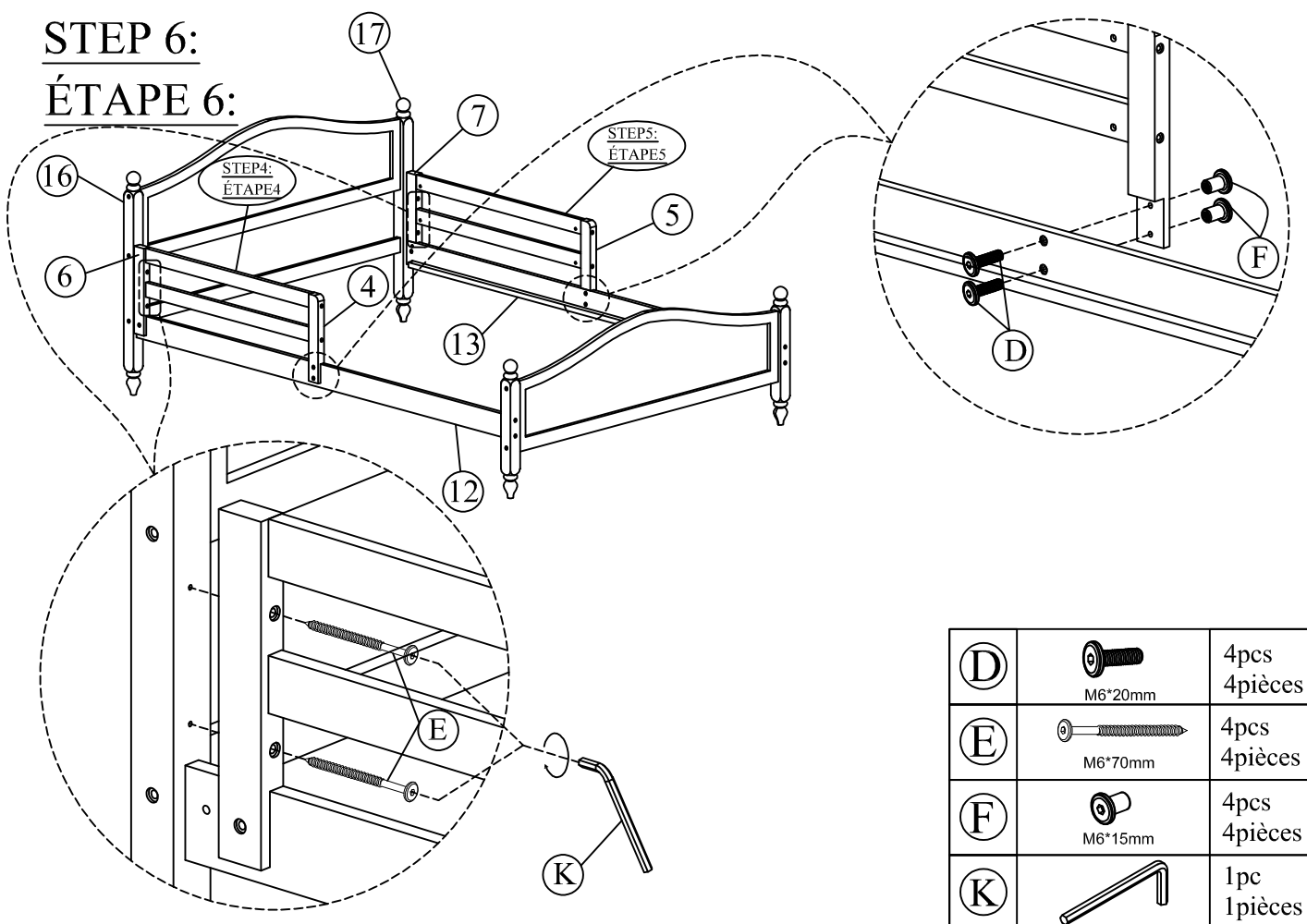

(A)	 Ø8*30mm	4pcs 4pièces
(C)	 M6*90mm	4pcs 4pièces
(K)		1pc 1pièces

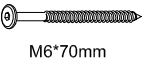

STEP 6:
ÉTAPE 6:

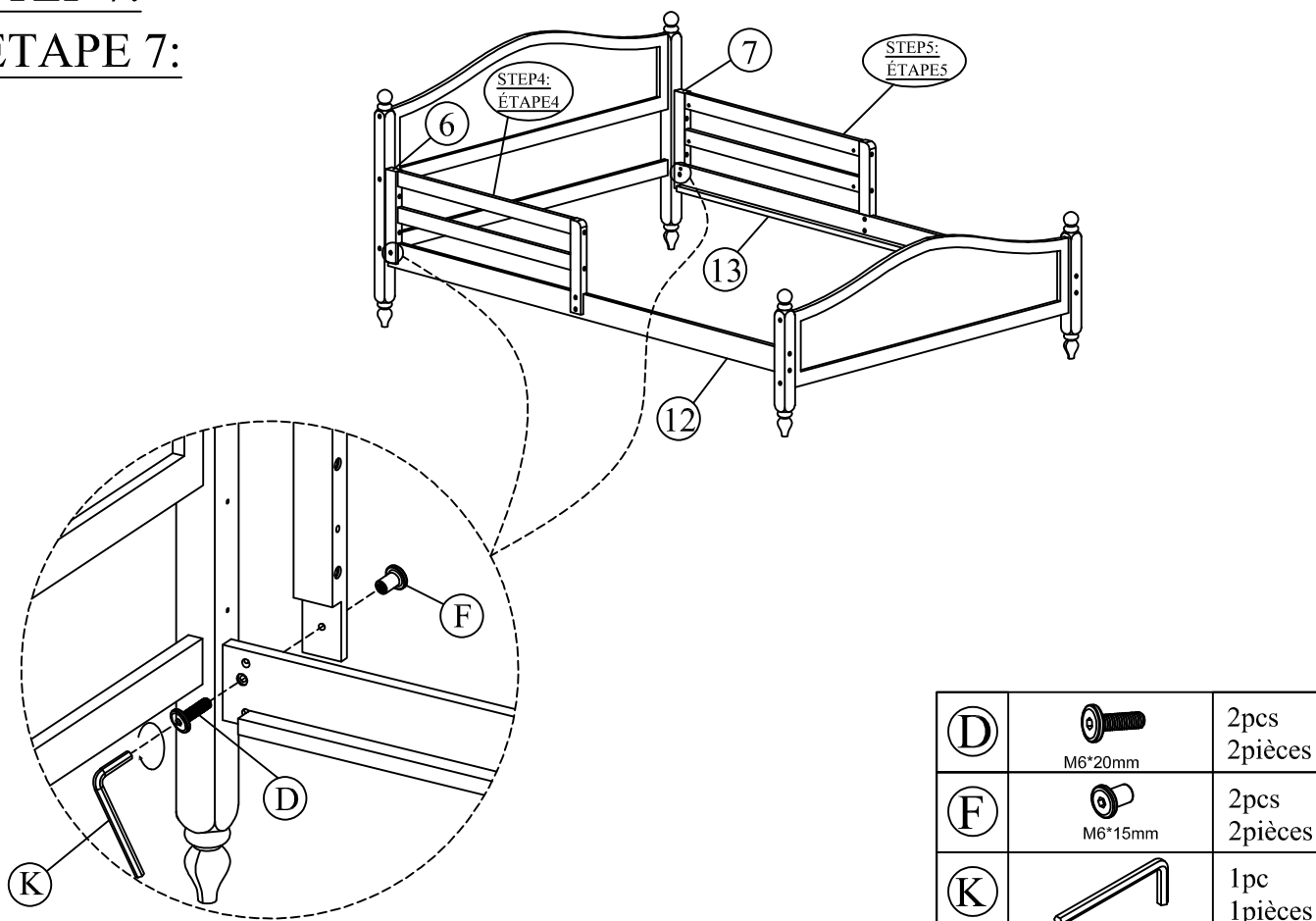

(D)	 M6*20mm	4pcs 4pièces
(E)	 M6*70mm	4pcs 4pièces
(F)	 M6*15mm	4pcs 4pièces
(K)		1pc 1pièces

STEP 7:
ÉTAPE 7:





(D)	 M6*20mm	2pcs 2pièces
(F)	 M6*15mm	2pcs 2pièces
(K)		1pc 1pièces

STEP 8:
ÉTAPE 8:

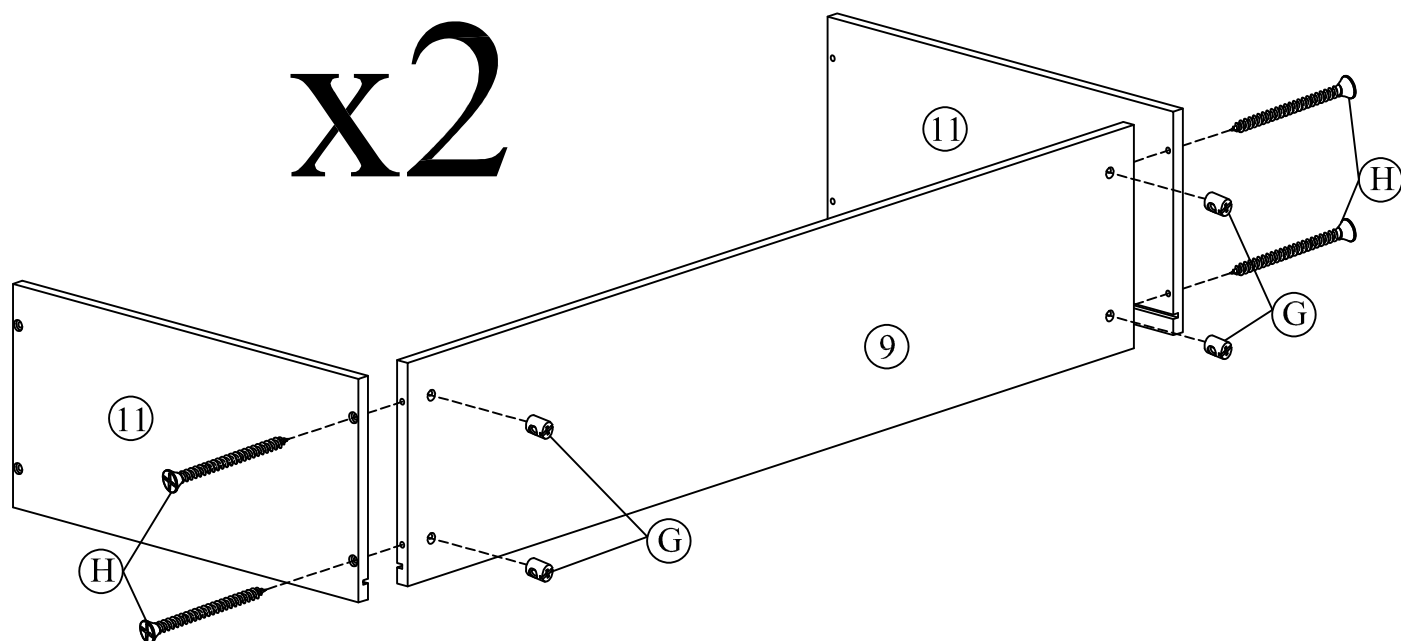
x2



(G)	 Ø10*10mm	8pcs 8pièces
(H)	 #8*50mm	8pcs 8pièces

STEP 9:
ÉTAPE 9:

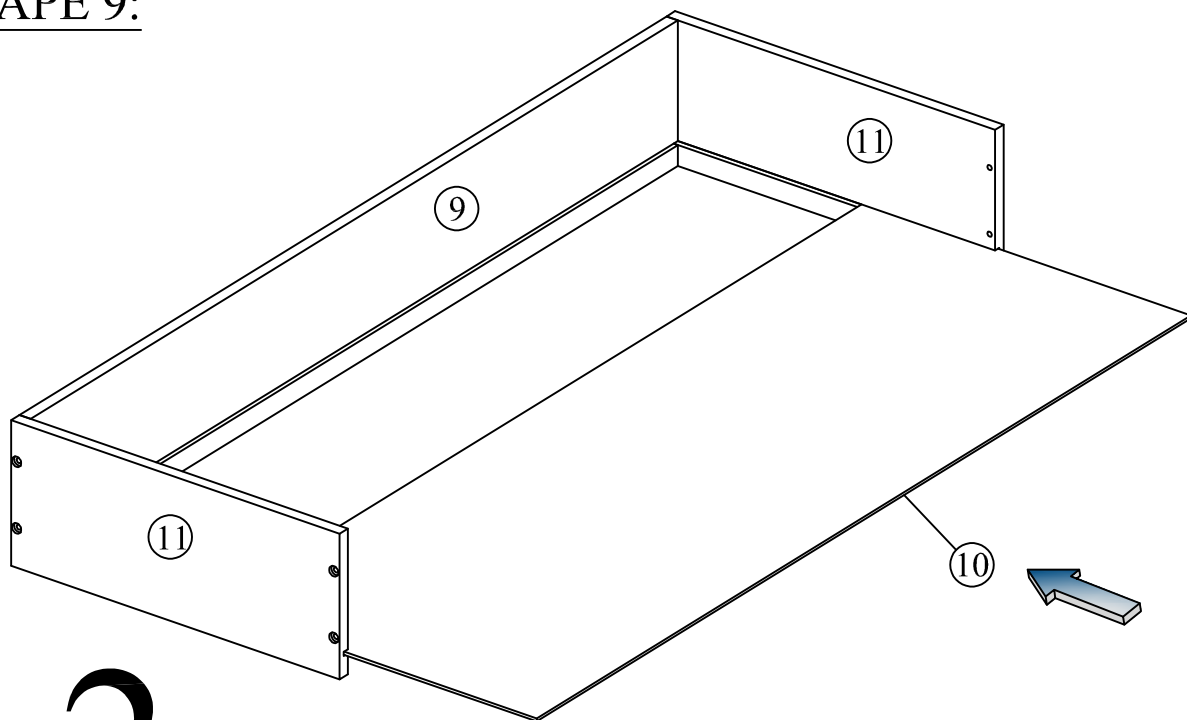

x2

STEP 10:
ÉTAPE 10:

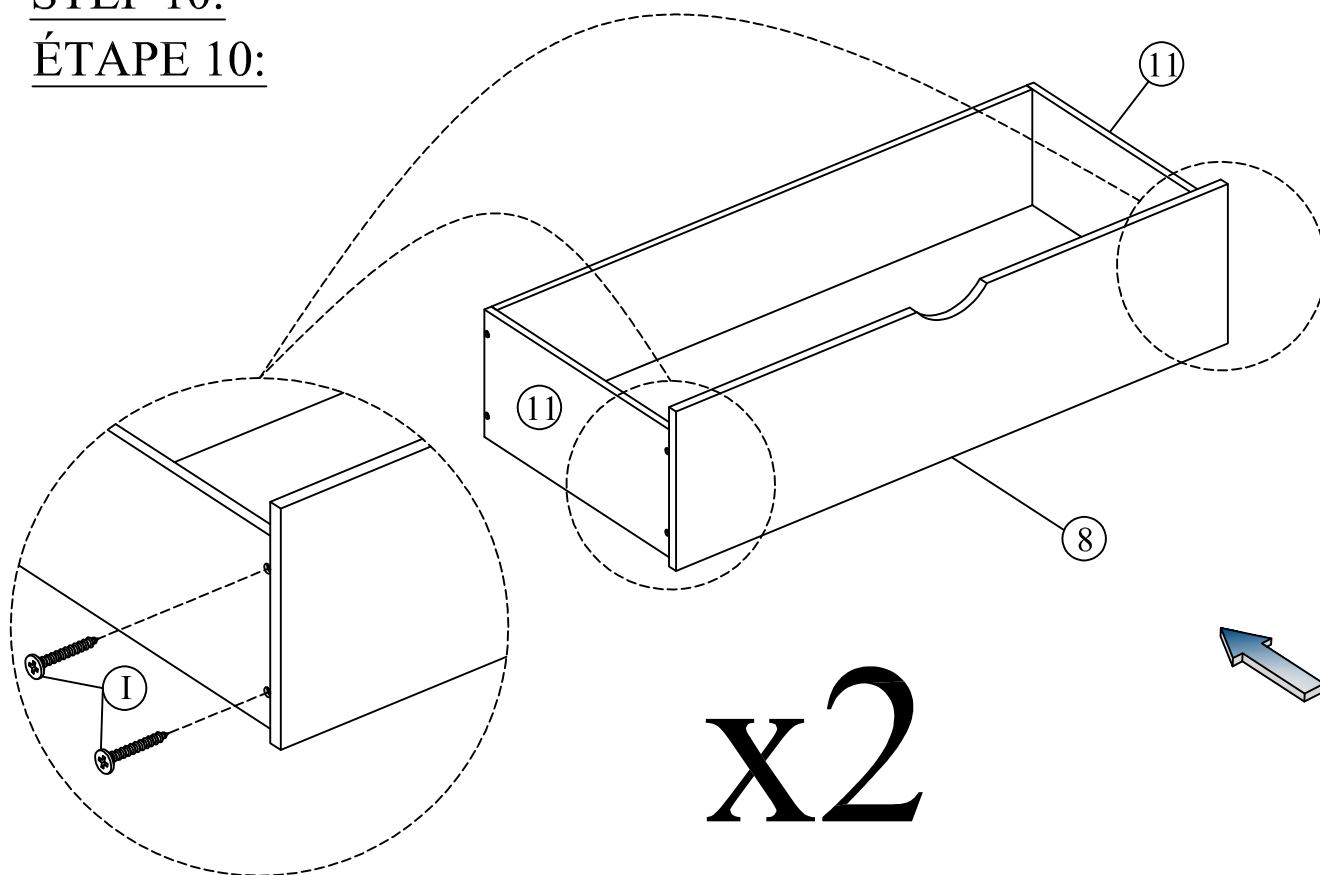

x2

I	 #8*25mm	8pcs 8pièces
---	--	-----------------

STEP 11:
ÉTAPE 11:

I	 #8*25mm	2pcs 2pièces
---	--	-----------------

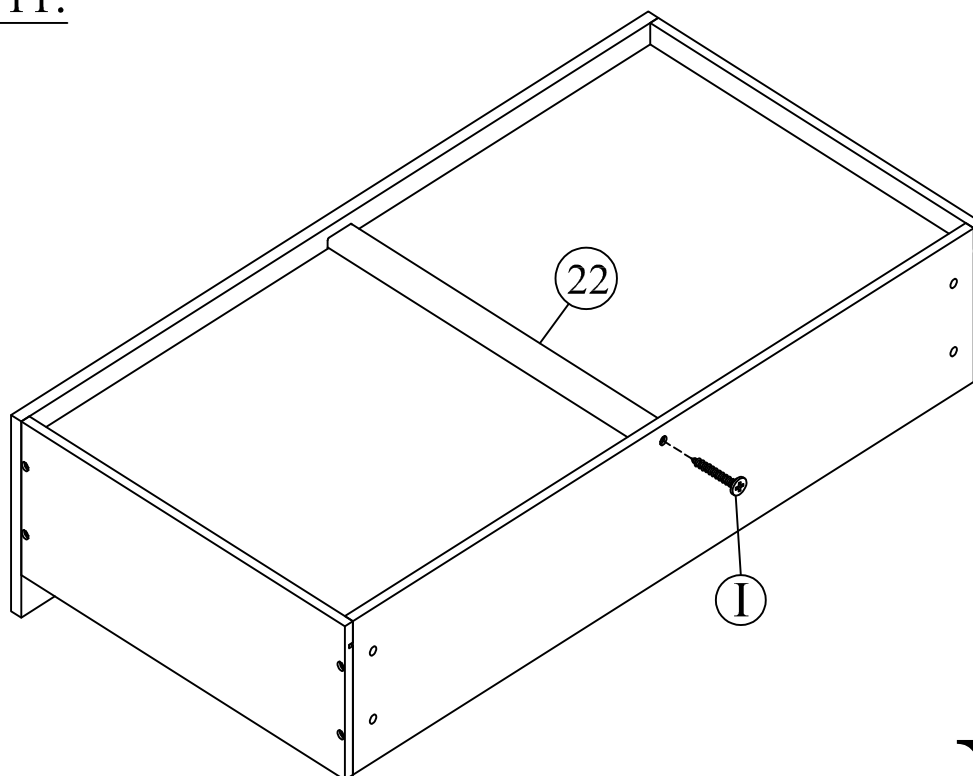



x2

STEP 12:
ÉTAPE 12:

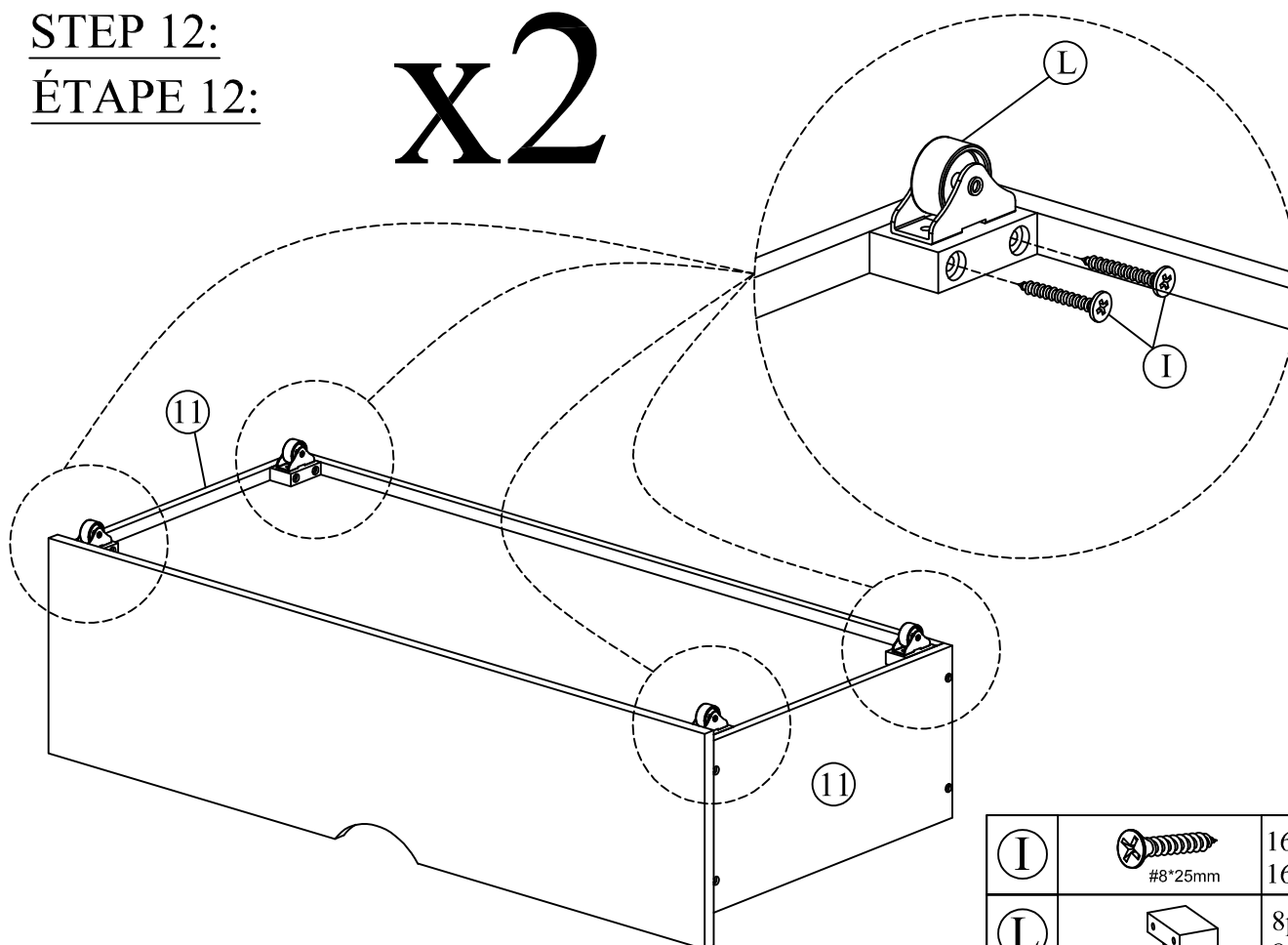
x2



I	 #8*25mm	16pcs 16pièces
L		8pcs 8pièces

STEP 13:
ÉTAPE 13:

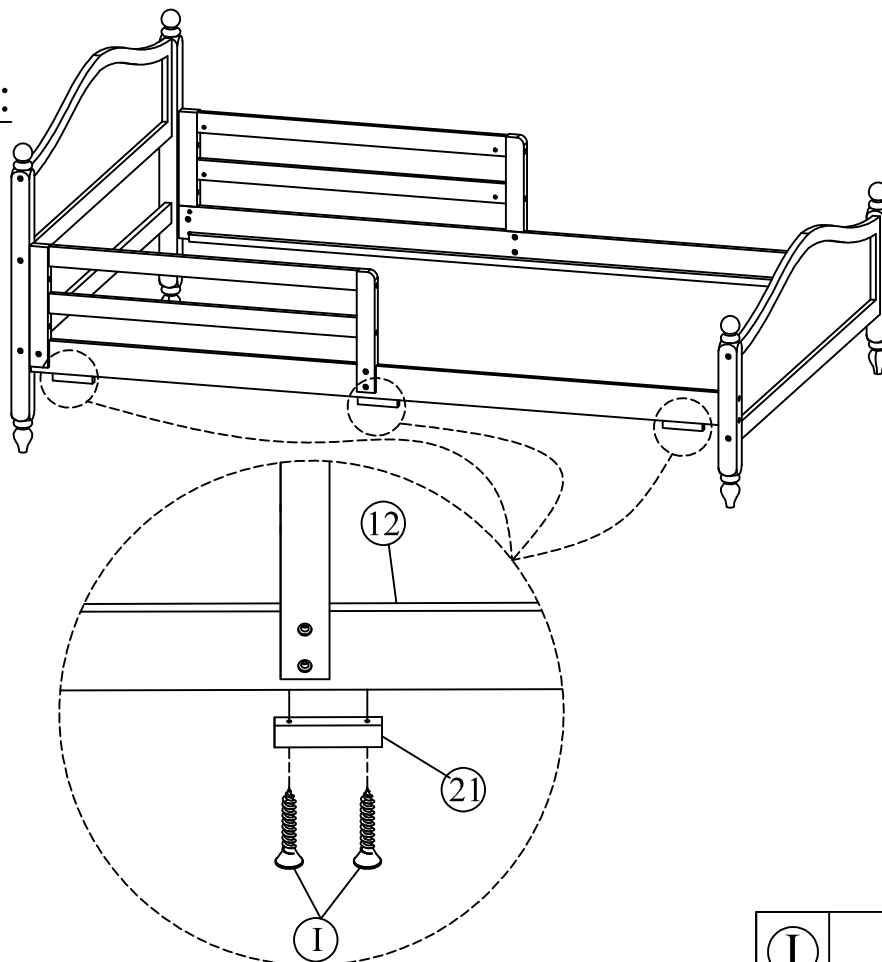

I	 #8*25mm	6pcs 6pièces
---	--	-----------------

STEP 14:
ÉTAPE 14:

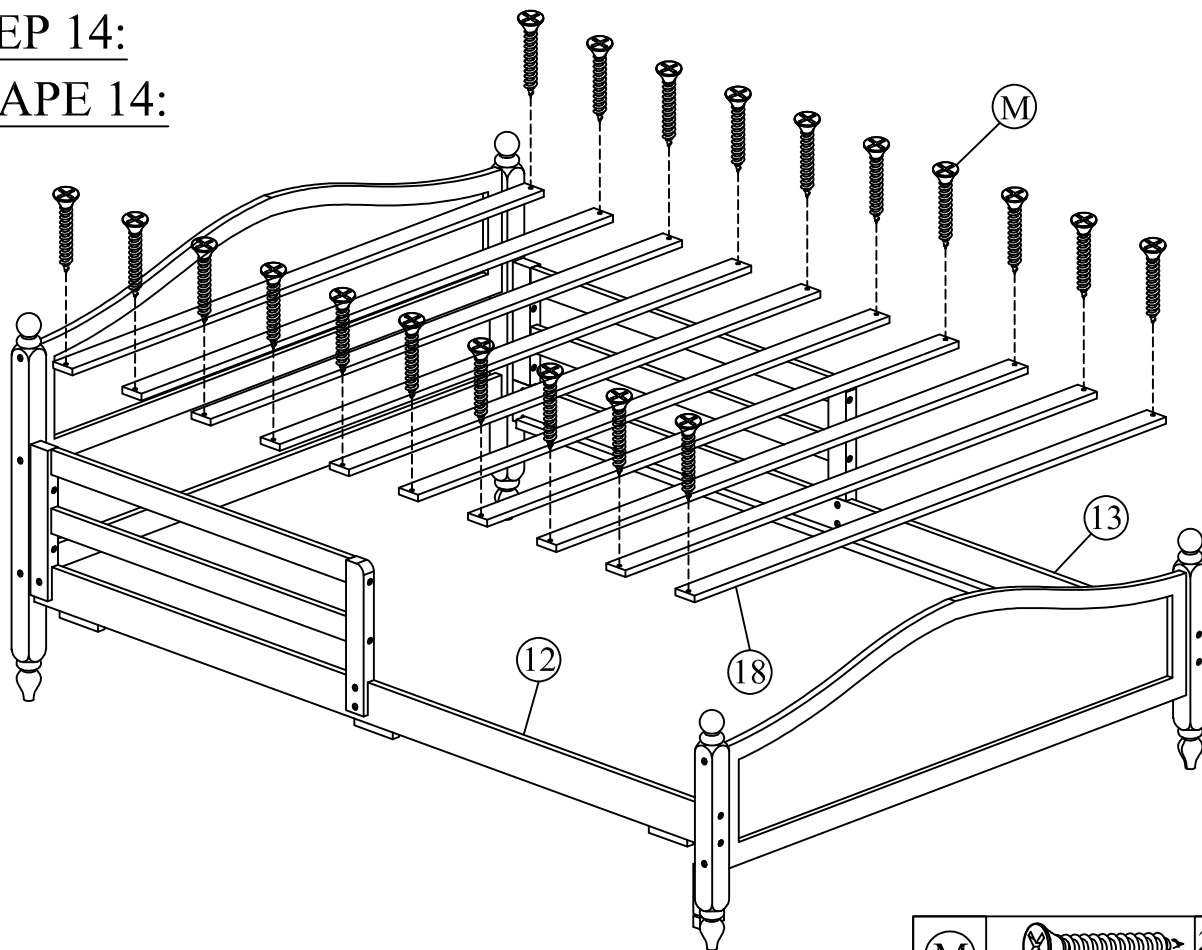

M	 #8*30mm	20pcs 20pièces
---	--	-------------------

STEP 15:
ÉTAPE 15:

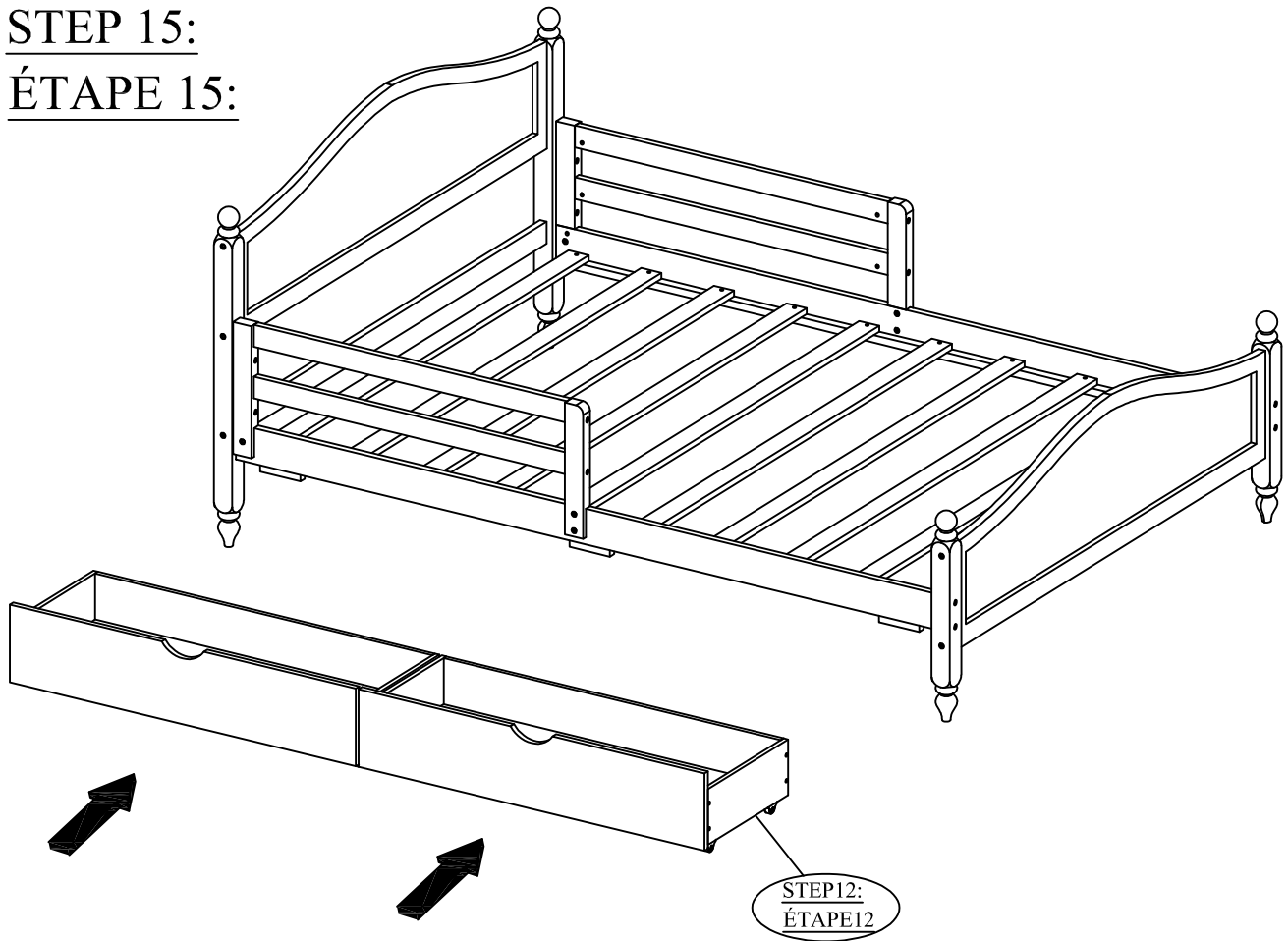

FINAL:
FINALE:

