

ASSEMBLY INSTRUCTION

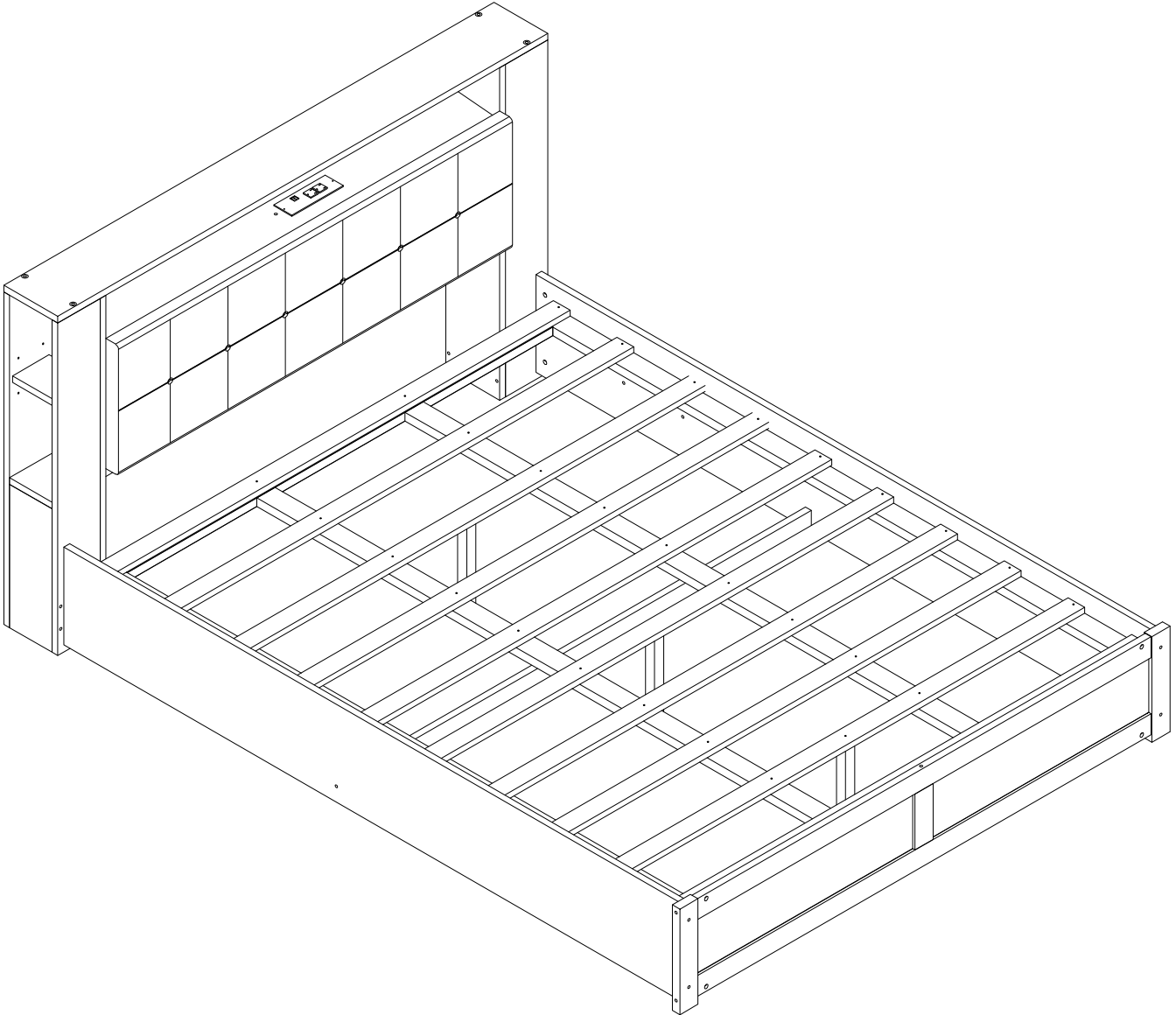

SKU CODE: (WF317386-WF317387)

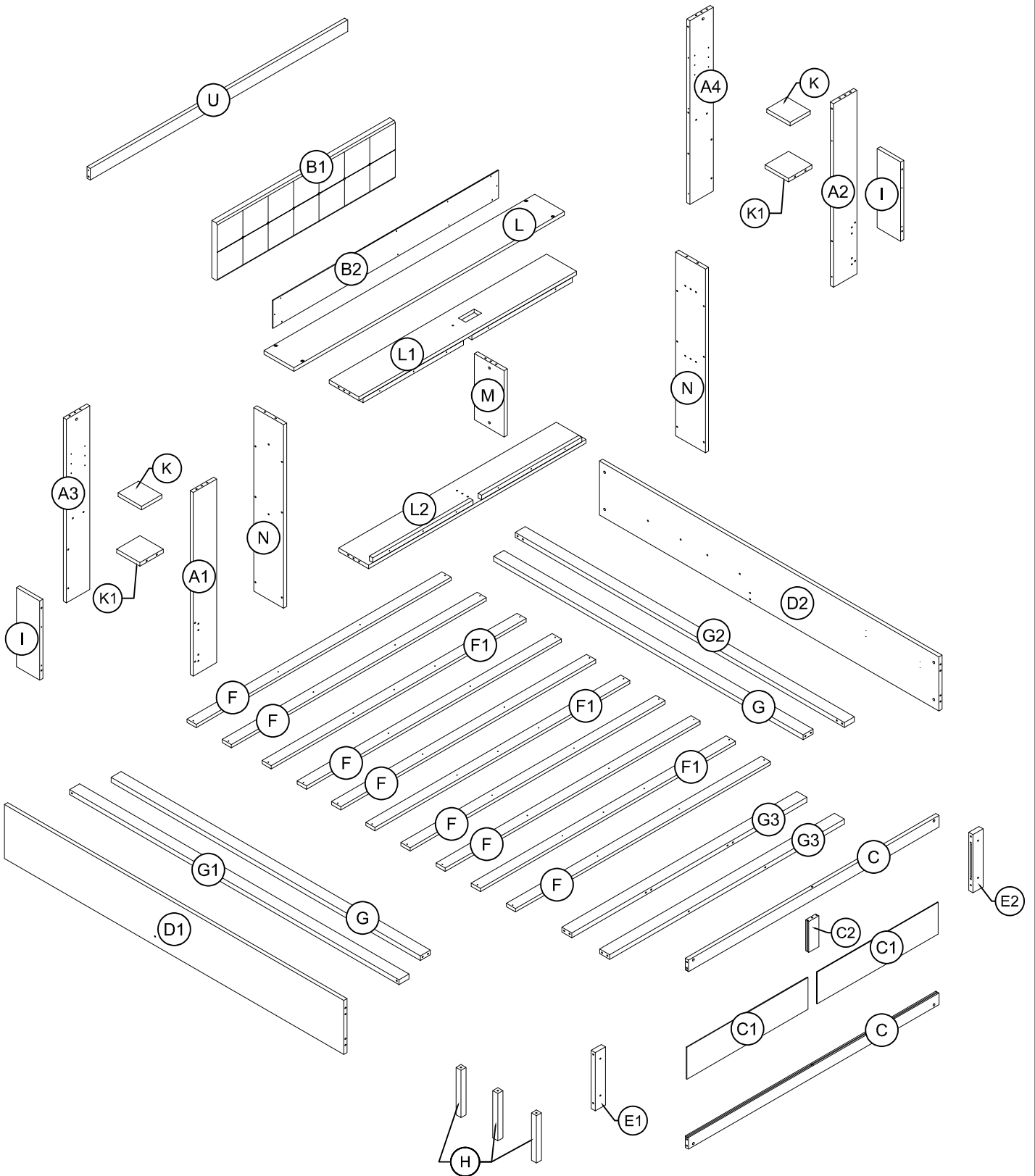





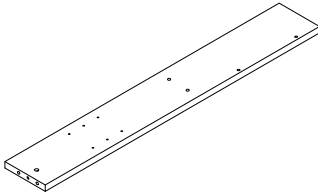
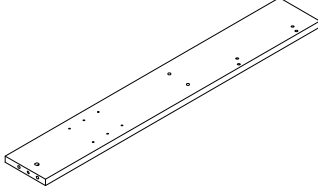
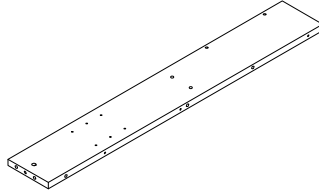
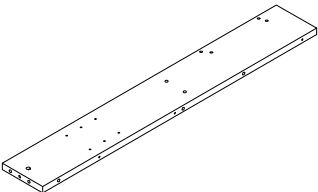
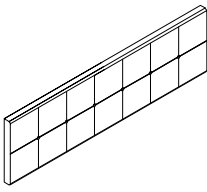
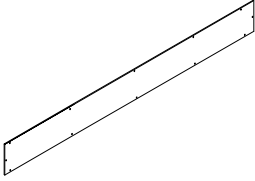
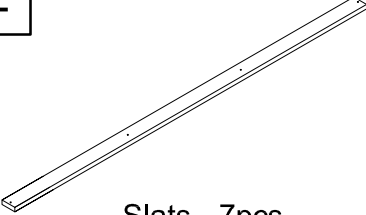
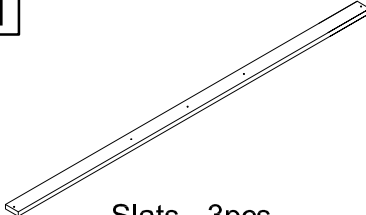
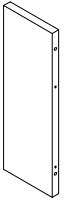
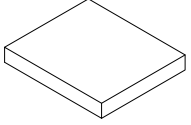
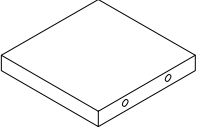
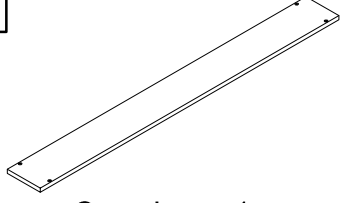
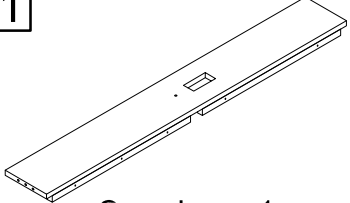
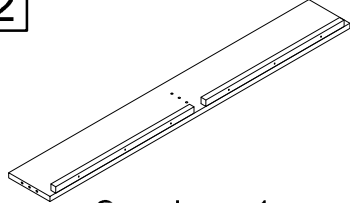
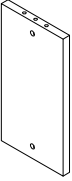



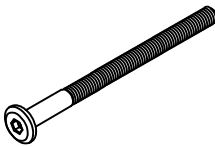

ASSEMBLY INSTRUCTION

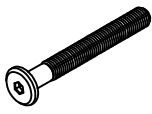

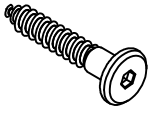
Part List (WF317386)



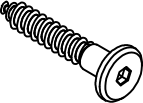
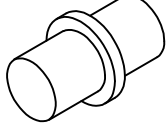
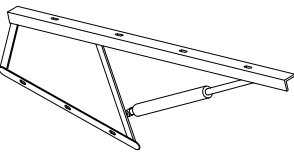
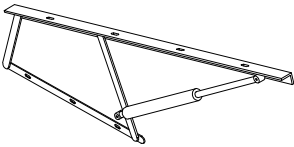

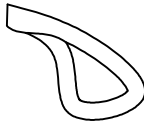
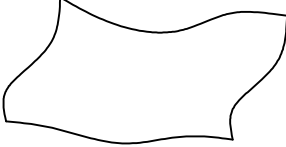
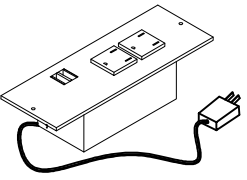
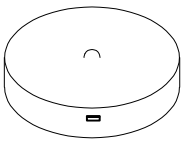
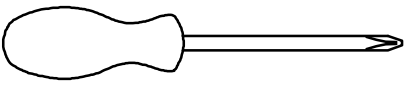
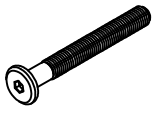
<p>A1</p>  <p>Leg (HB Font) - 1pc</p>	<p>A2</p>  <p>Leg (HB Font) - 1pc</p>	<p>A3</p>  <p>Leg (HB Font) - 1pc</p>
<p>A4</p>  <p>Leg (HB Font) - 1pc</p>	<p>B1</p>  <p>HB Frames - 1pc</p>	<p>B2</p>  <p>Sheets - 1pc</p>
<p>F</p>  <p>Slats - 7pcs</p>	<p>F1</p>  <p>Slats - 3pcs</p>	<p>I</p>  <p>Standing Plate - 2pcs</p>
<p>K</p>  <p>Crossbar - 2pcs</p>	<p>K1</p>  <p>Crossbar - 2pcs</p>	<p>L</p>  <p>Crossbar - 1pc</p>
<p>L1</p>  <p>Crossbar - 1pc</p>	<p>L2</p>  <p>Crossbar - 1pc</p>	<p>M</p>  <p>Standing Plate - 1pc</p>
<p>N</p>  <p>Standing Plate - 2pcs</p>		

Hardware List (WF317386)

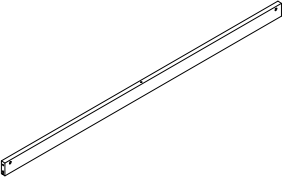
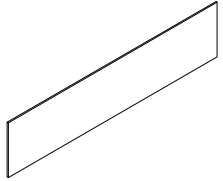
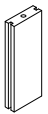
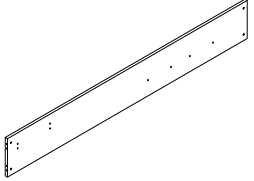
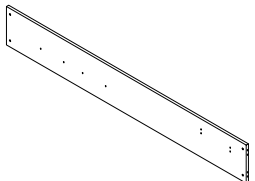

<p>1</p>  <p>1/4" x 100mm Hex-Head bolts 14pcs</p>	<p>2</p>  <p>Allen Key 1pcs</p>	<p>3</p>  <p>1/4" x 60mm Hex-Head bolts 8pcs</p>
<p>4</p>  <p>1/4" x 30mm Hex-Head bolts 3pcs</p>	<p>5</p>  <p>1/4" x 20mm Hex-Head bolts 8pcs</p>	<p>6</p>  <p>1/4" x 20mm Wood Screws 8pcs</p>
<p>7</p>  <p>Ø8 x 30mm Wood Dowel 74pcs</p>	<p>8</p>  <p>1/4" x 15mm Horizontal -Hole bolts 32pcs</p>	<p>9</p>  <p>M4 x 15 mm Wood Screws 20pcs</p>
<p>10</p>  <p>M4 x 30 mm Wood Screws 53pcs</p>	<p>11</p>  <p>1/4" x 50mm Wood Screws 22pcs</p>	<p>12</p>  <p>Support Pin 8pcs</p>
<p>13</p>  <p>Piston Left 1pc</p>	<p>14</p>  <p>Piston Right 1pc</p>	<p>15</p>  <p>Steel Bracket 4pcs</p>
<p>16</p>  <p>Pabric 1pc</p>	<p>17</p>  <p>Carpet Fabric 1pc</p>	<p>18</p>  <p>USB Power outlet 1pc</p>
<p>19</p>  <p>Touch Led Light 1pc</p>		<p>20</p>  <p>1/4" x 50mm Hex-Head bolts 10pcs</p>

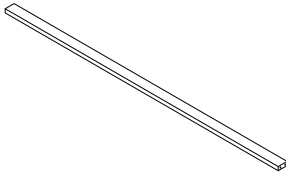
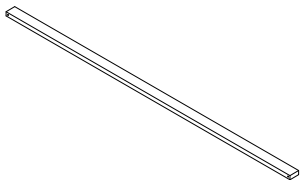
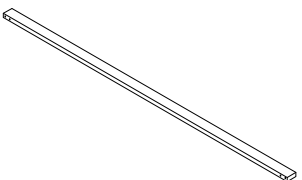
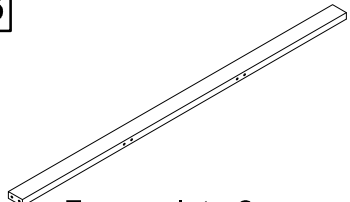
Assembly Tools Required (Not Included)

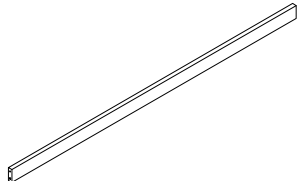
Part List (WF317387)

<p>C</p>  <p>Cross Bar - 2pcs</p>	<p>C1</p>  <p>Sheets (FB Back)- 2pcs</p>	<p>C2</p>  <p>Sliding Plate - 1pc</p>
<p>D1</p>  <p>Side Rails Left - 1pc</p>	<p>D2</p>  <p>Side Rails Right - 1pc</p>	<p>E1</p>  <p>Leg (FB Back)- 1pc</p>
<p>E2</p>  <p>Leg (FB Back)- 1pc</p>	<p>G</p>  <p>Frame slat - 2pcs</p>	<p>G1</p>  <p>Frame Slat Left - 1pcs</p>
<p>G2</p>  <p>Frame Slat Right - 1pc</p>	<p>G3</p>  <p>Frame slat - 2pcs</p>	<p>H</p>  <p>Support Leg - 3pcs</p>
<p>U</p>  <p>Horizontal bar - 1pc</p>		

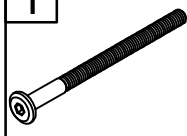
STEP 1: Following below illustration:

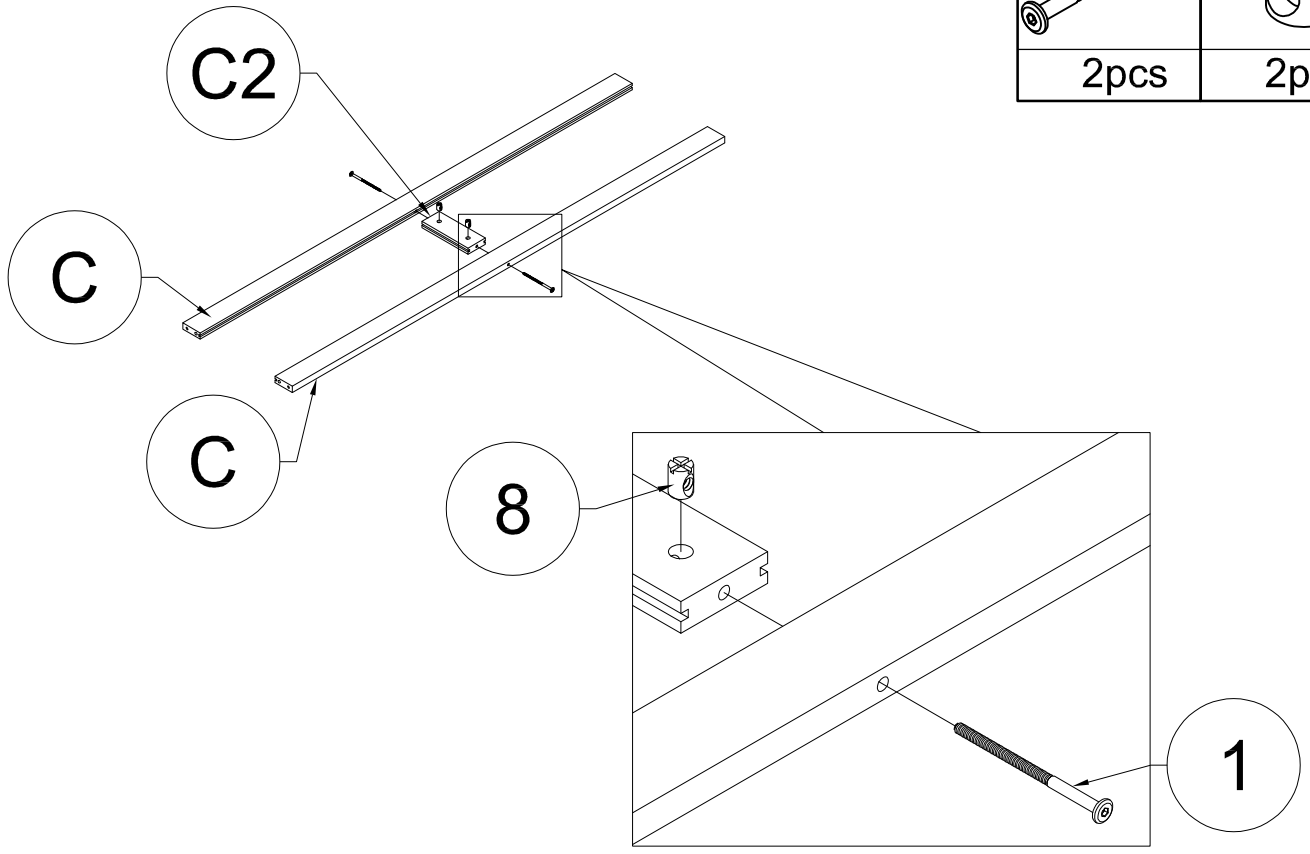

1	8
	
2pcs	2pcs

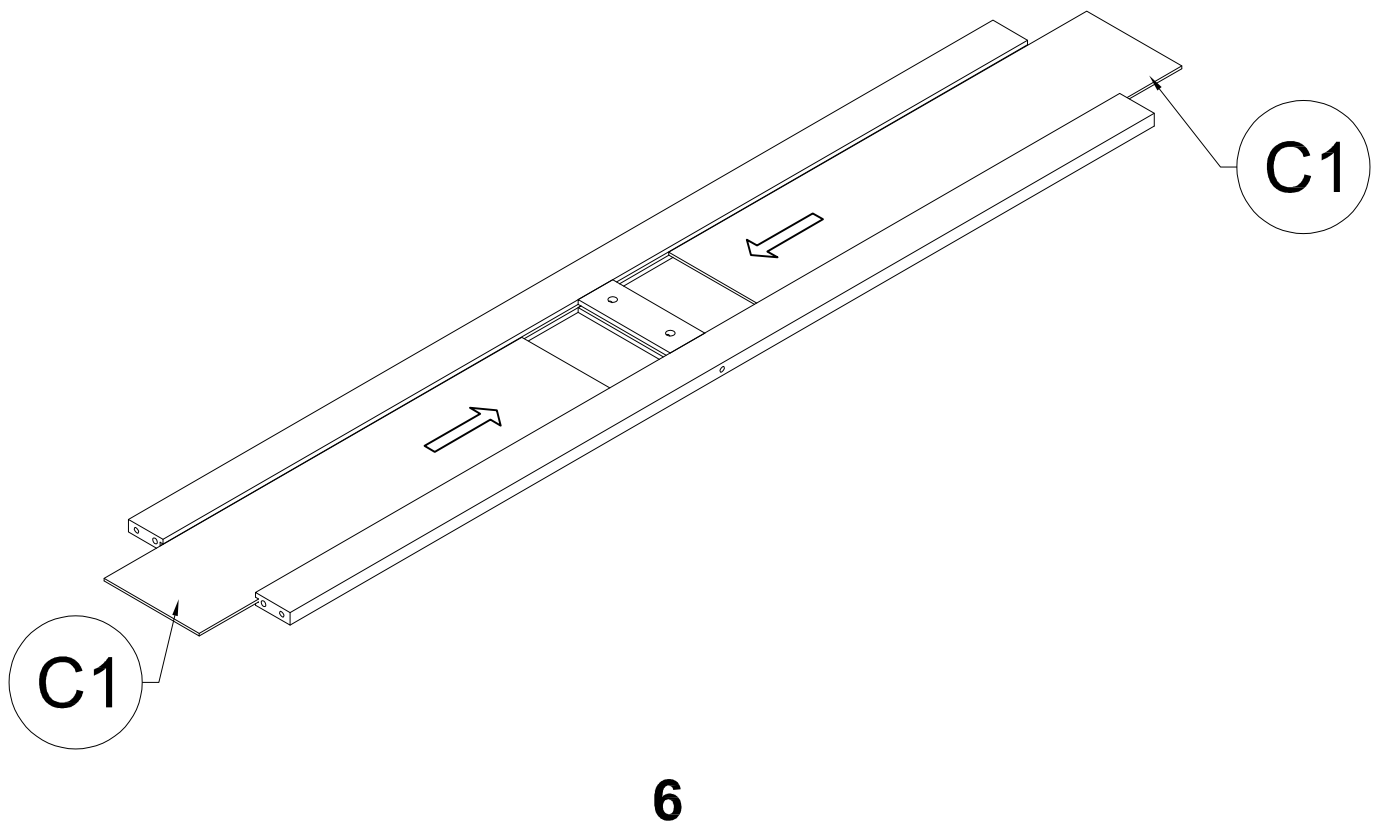

STEP 2: Following below illustration:

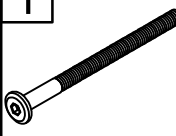

STEP 3: Following below illustration:

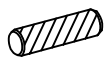
1	8	7
		
4pcs	4pcs	4pcs

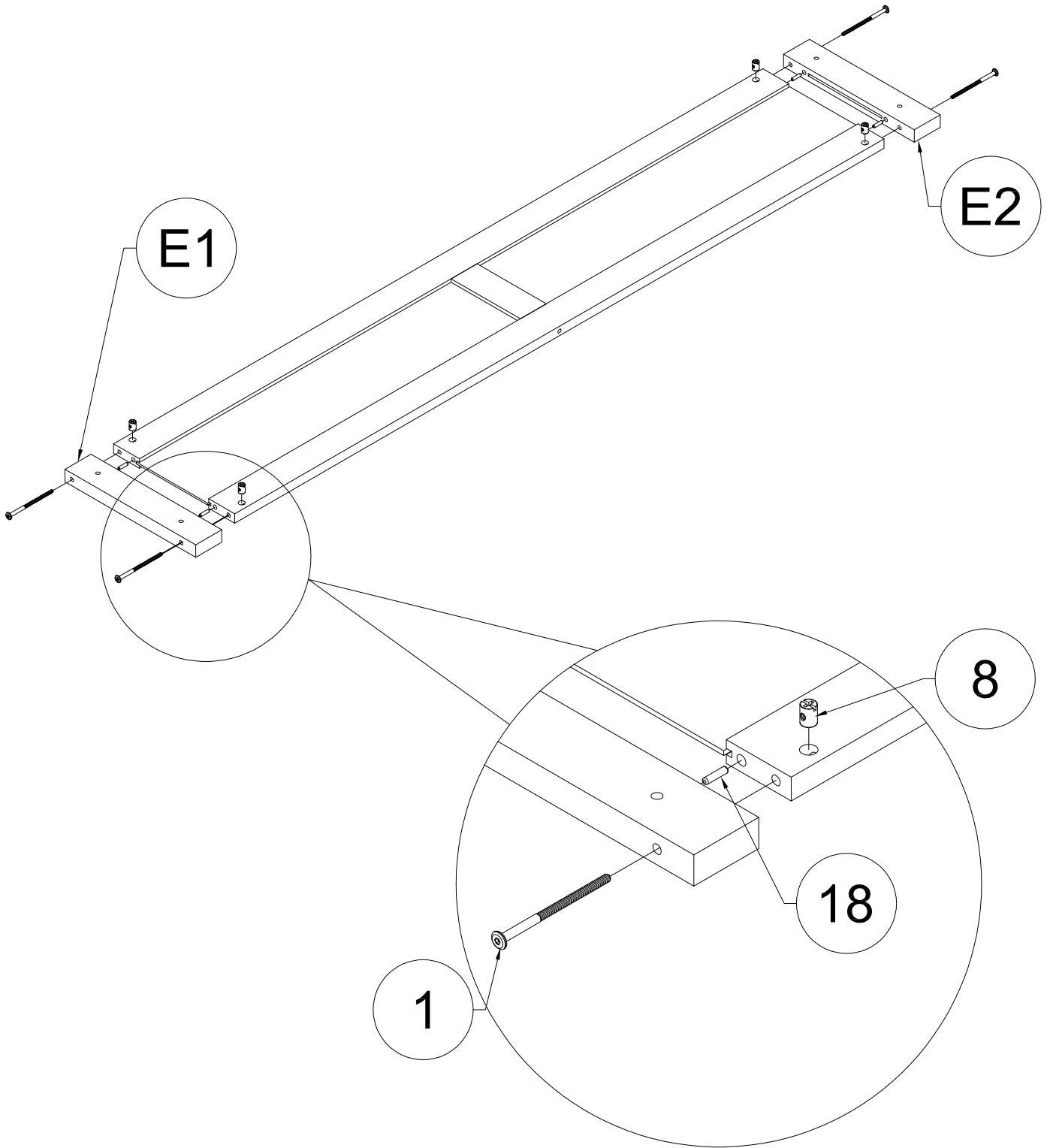

STEP 4: Following below illustration:

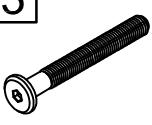
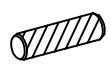
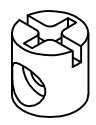
3	7	8
		
8pcs	8pcs	8pcs

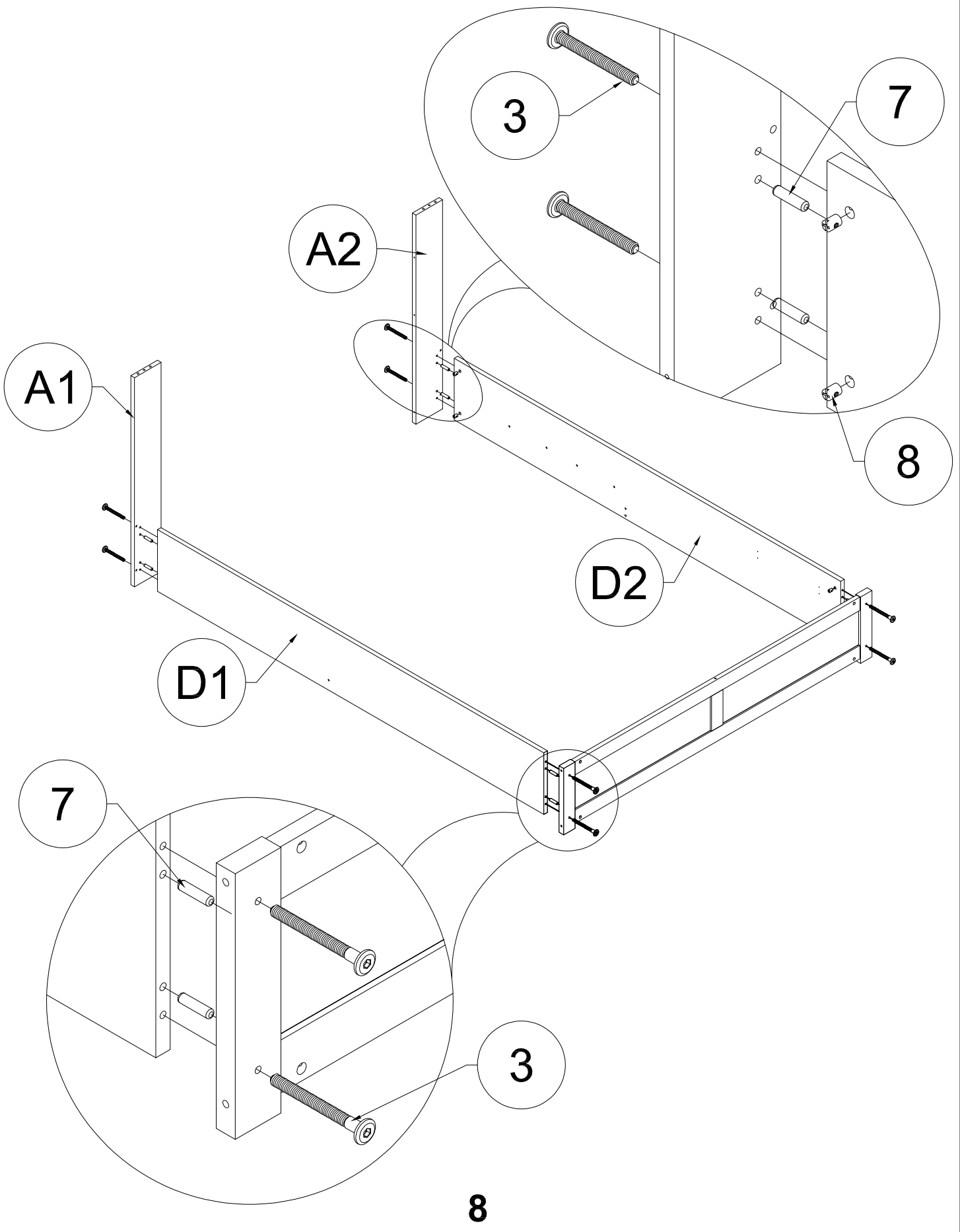

STEP 5: Following below illustration:

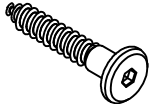
7	11
	
8pcs	4pcs

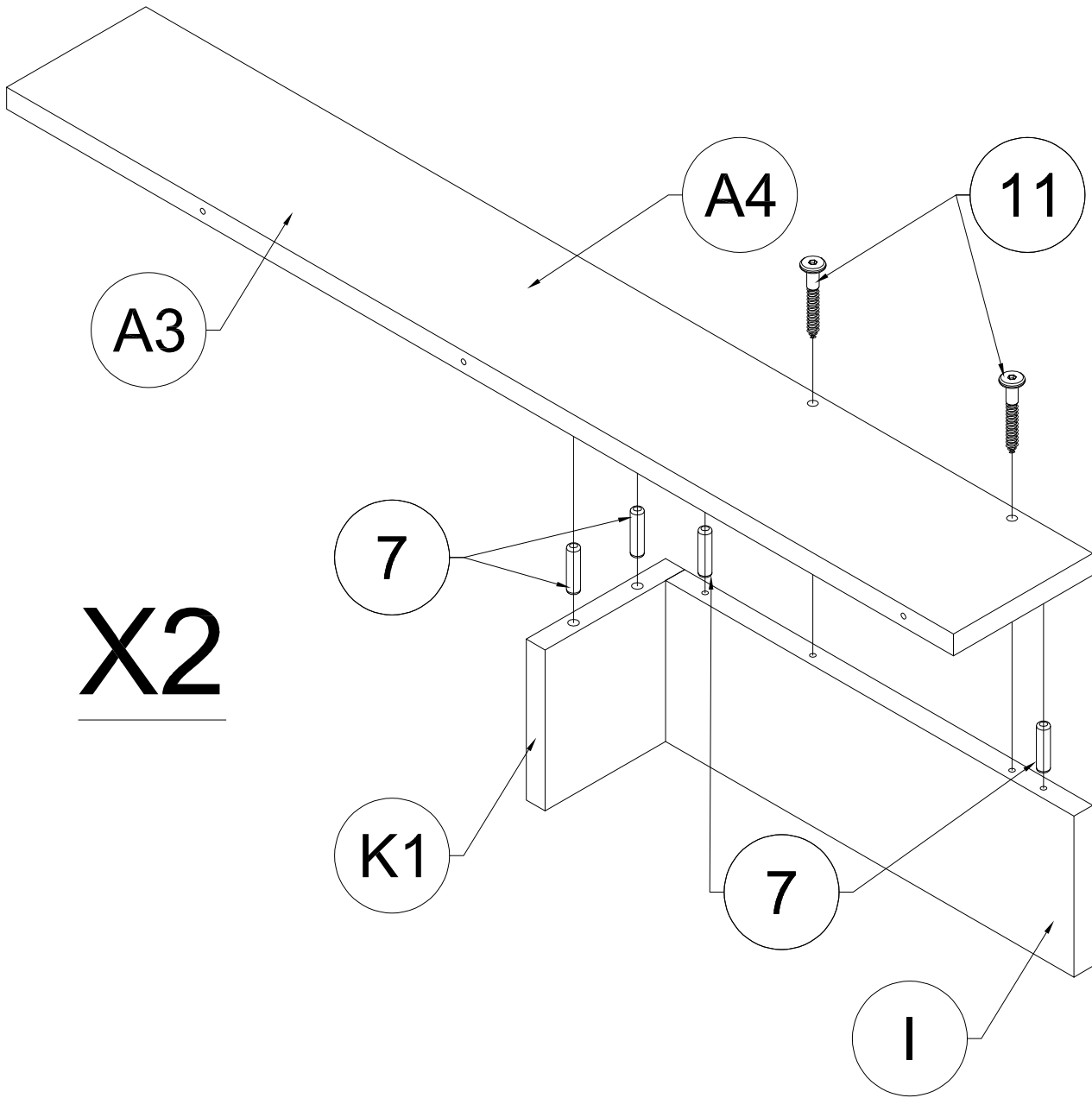

X2

STEP 6: Following below illustration:

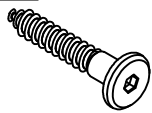
7	11
	
6pcs	6pcs

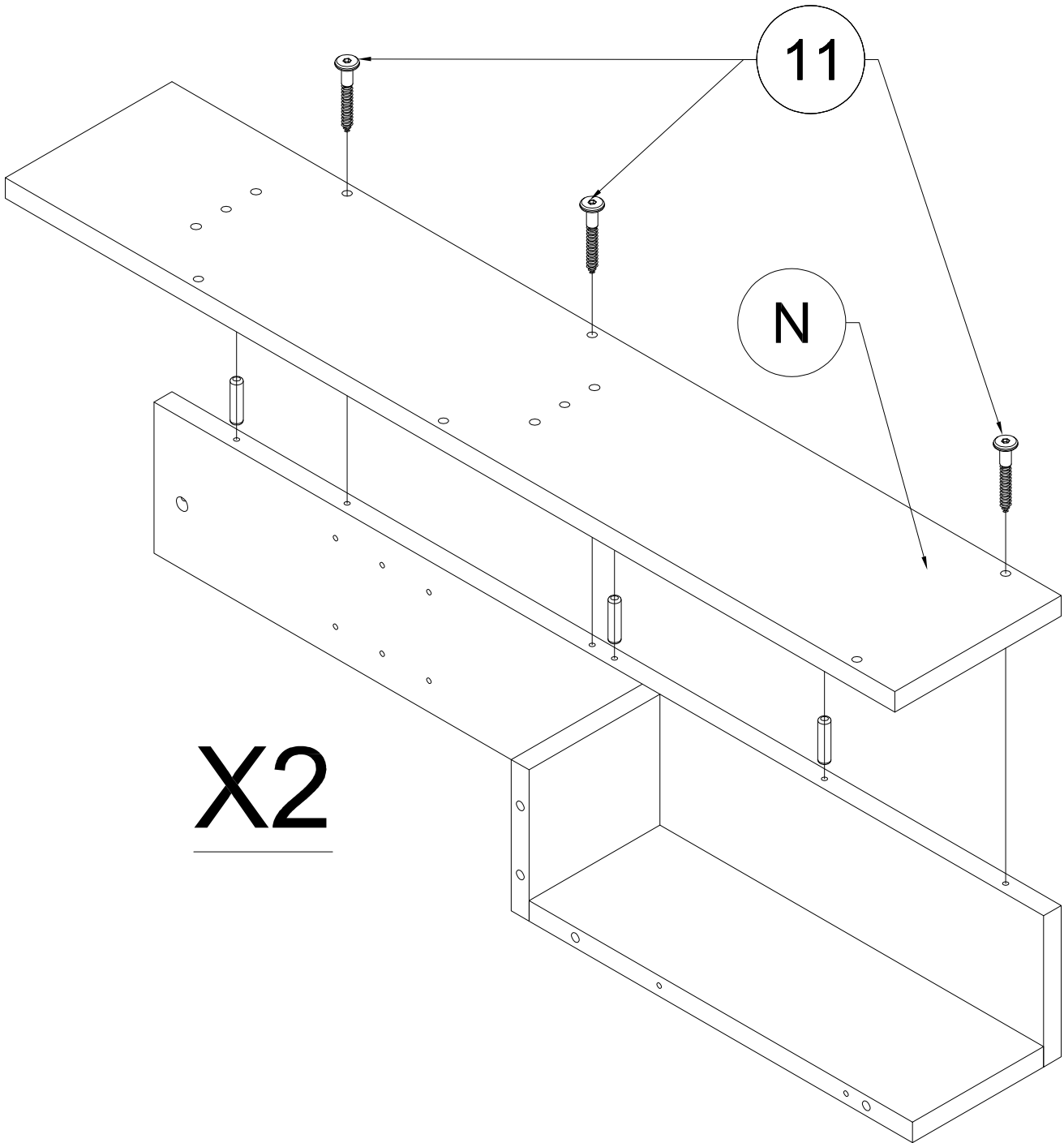

STEP 7-1: Following below illustration:

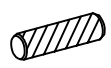
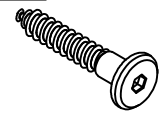
7	11
	
8pcs	4pcs

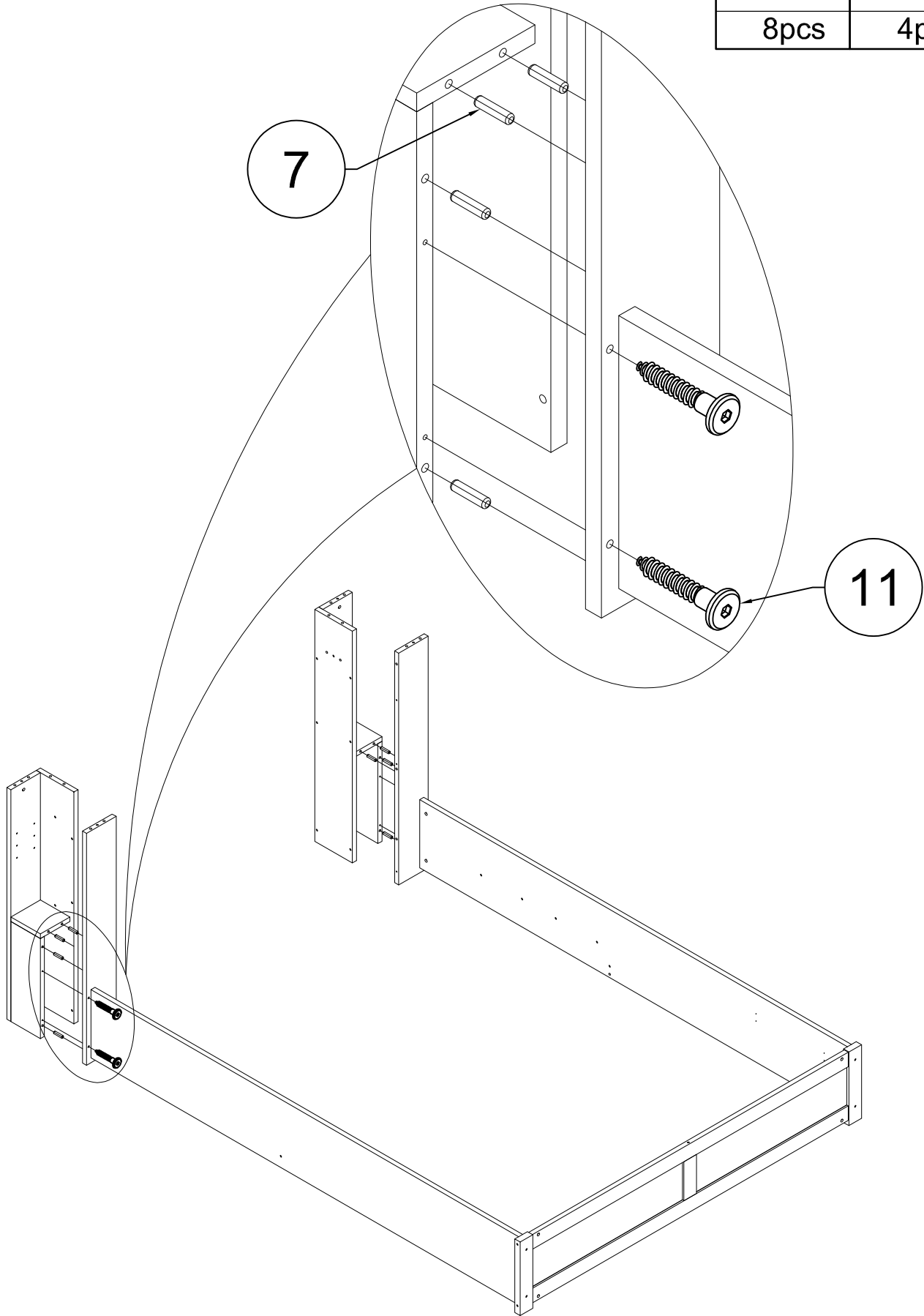

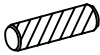
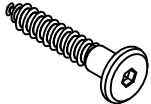

STEP 7-2: Following below illustration:

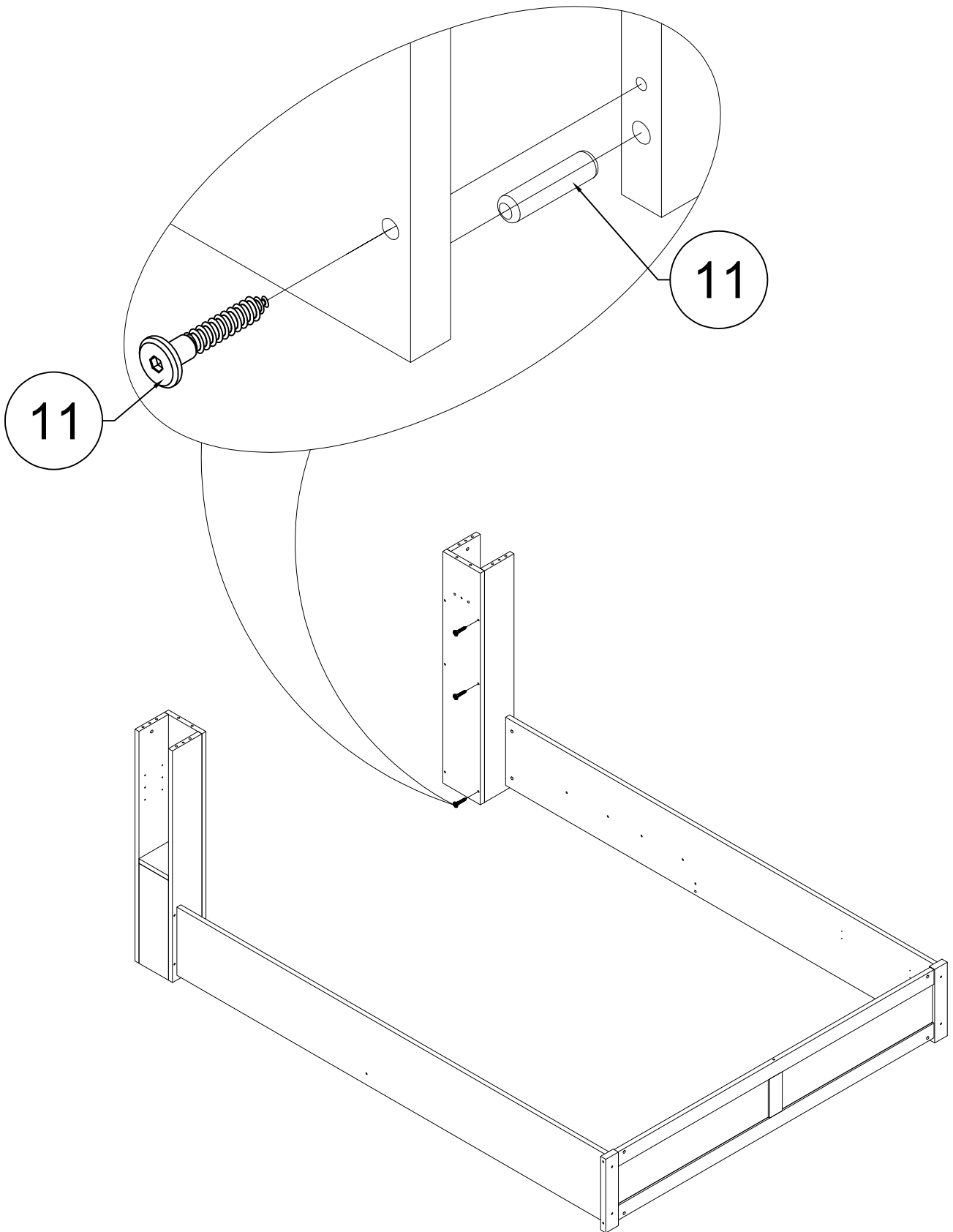
7	11
	
6pcs	6pcs



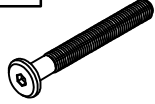

STEP 8: Following below illustration:

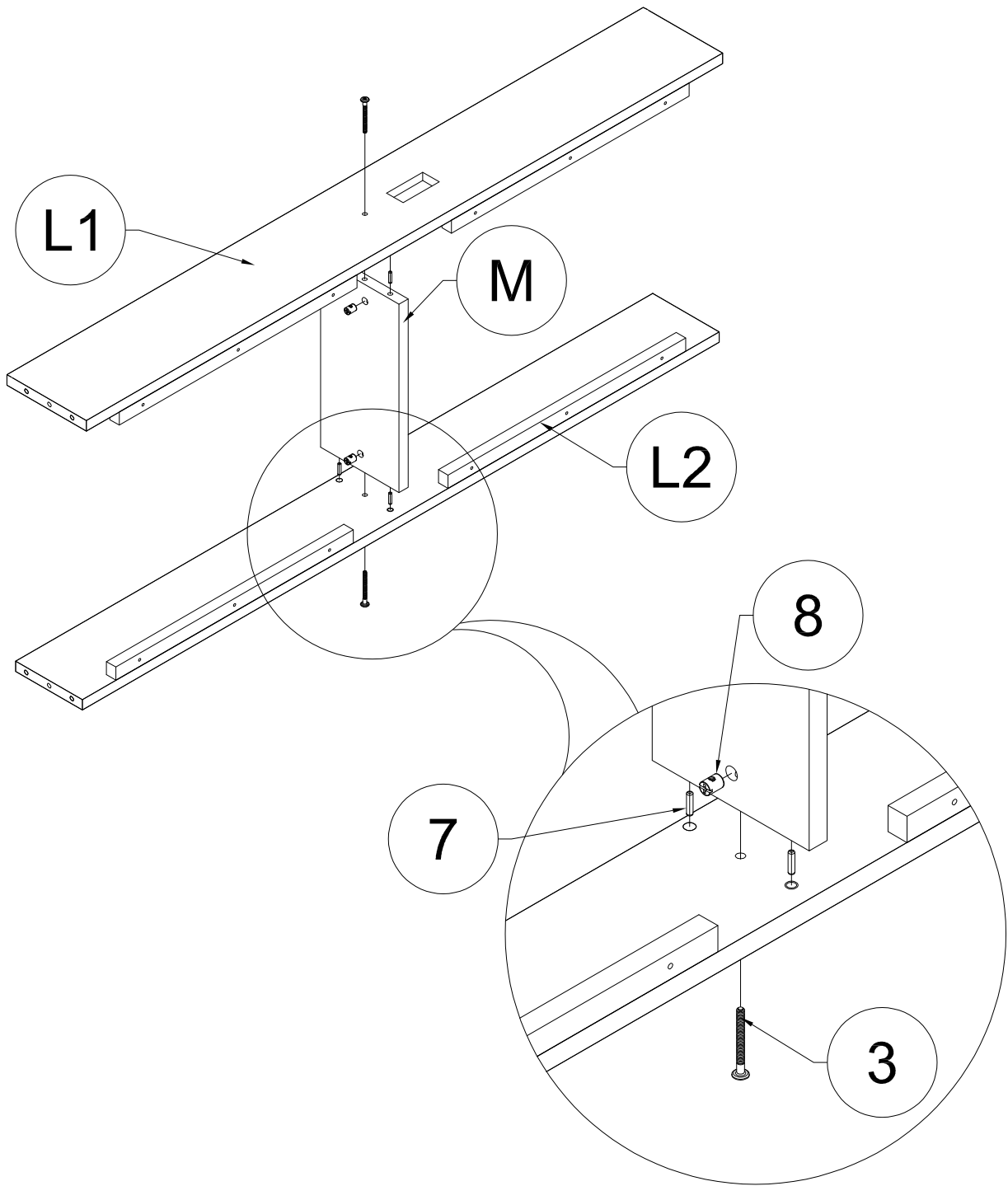
7	20	8
		
4pcs	2pcs	2pcs

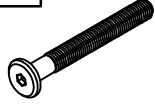

STEP 9: Following below illustration:

7	20	8
		
8pcs	4pcs	4pcs

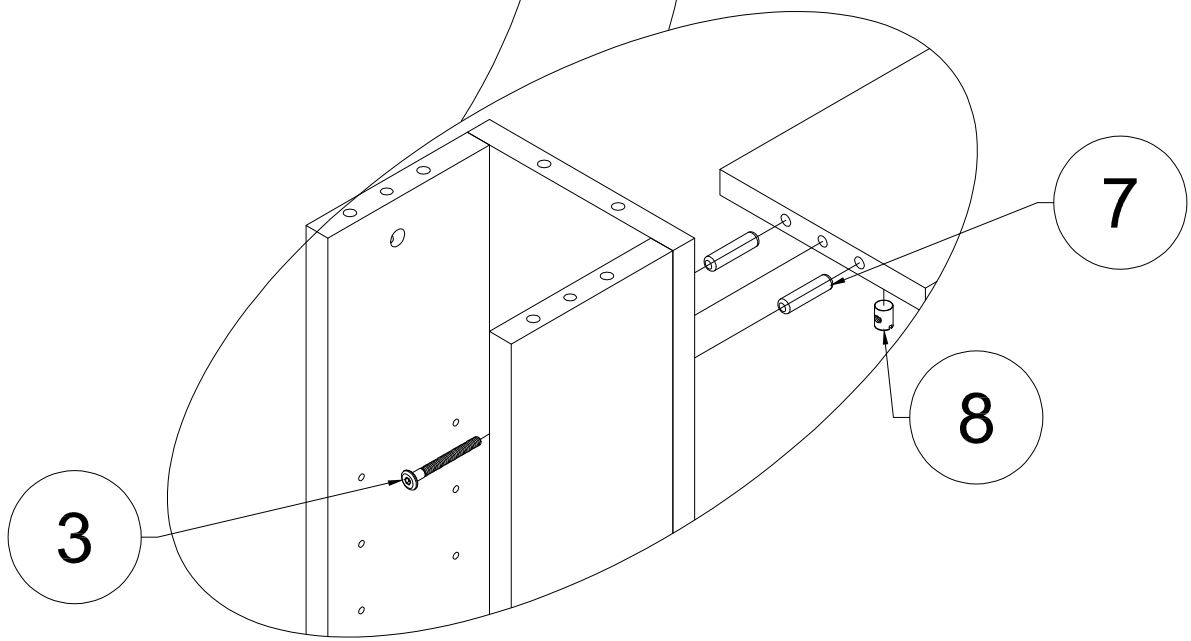
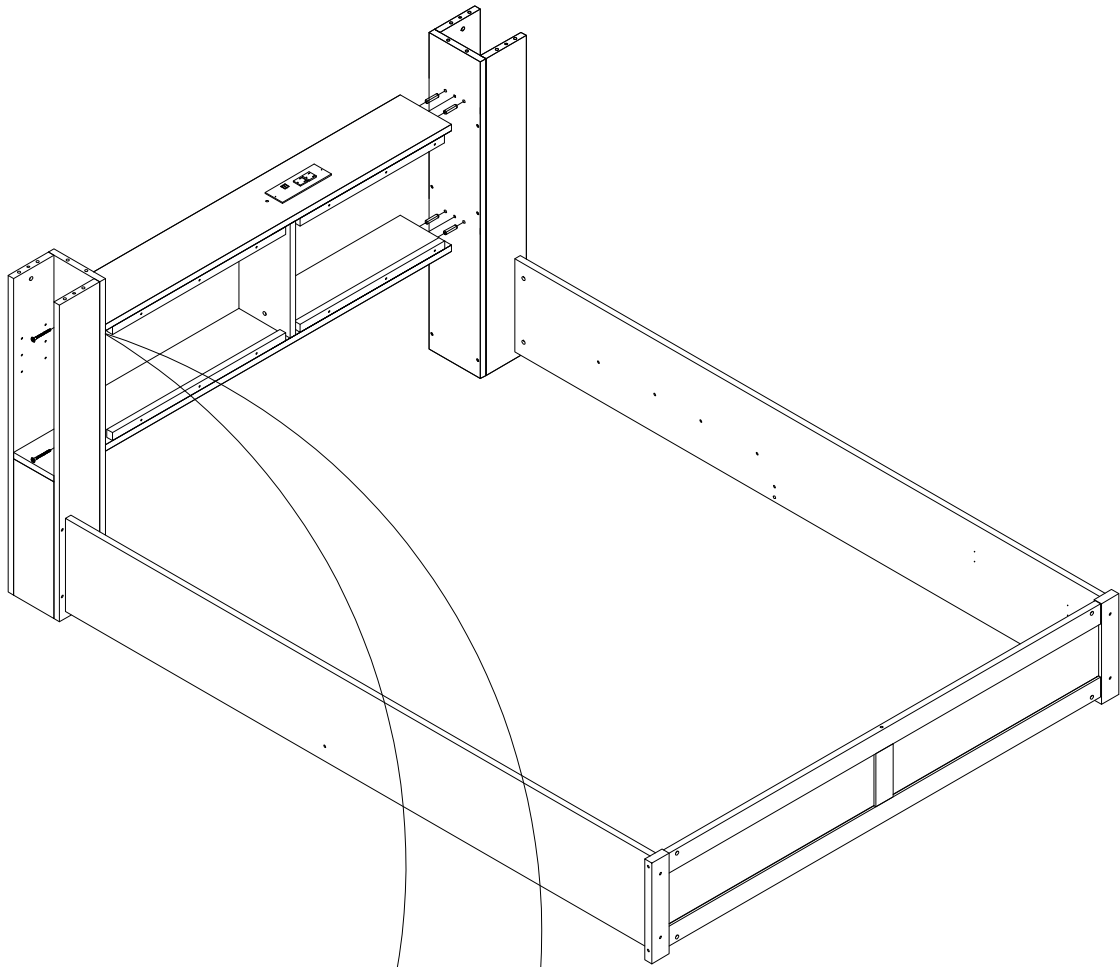

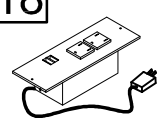

STEP 10: Following below illustration:

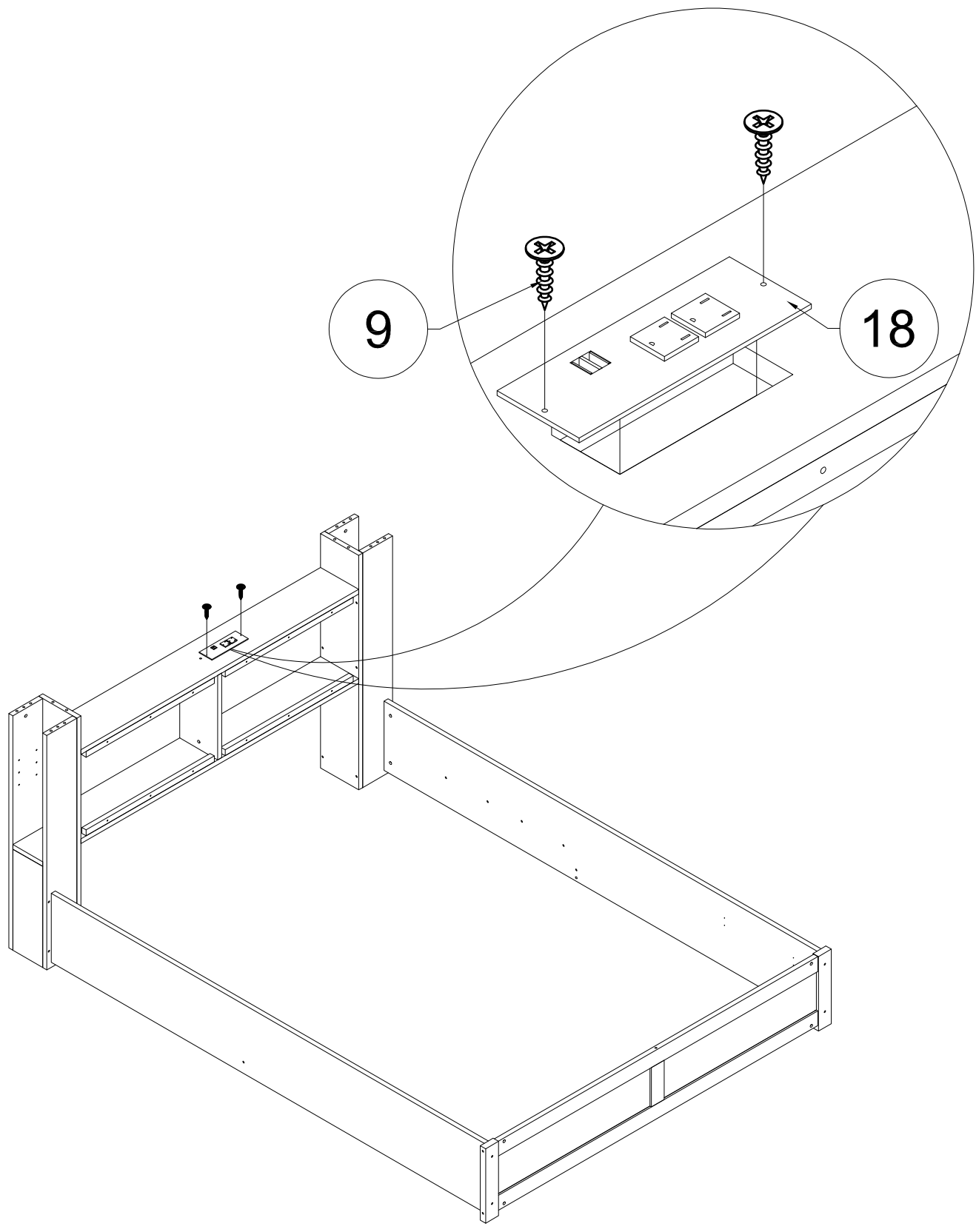
9	18
	
2pcs	1pc

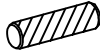
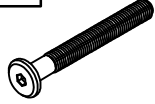

STEP 11: Following below illustration:

7	20	8
		
12pcs	4pcs	4pcs

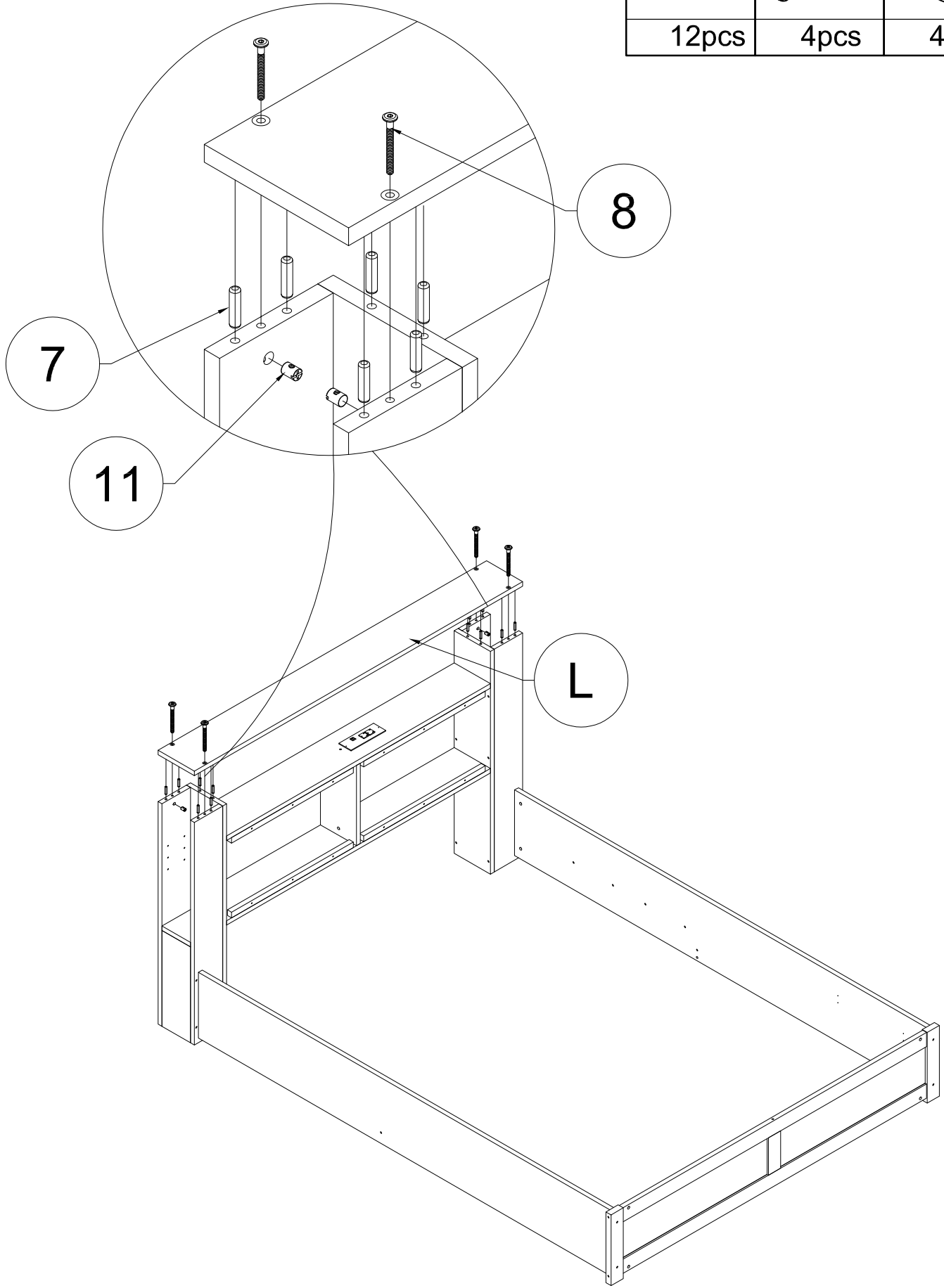

STEP 12: Following below illustration:

10	
12pcs	

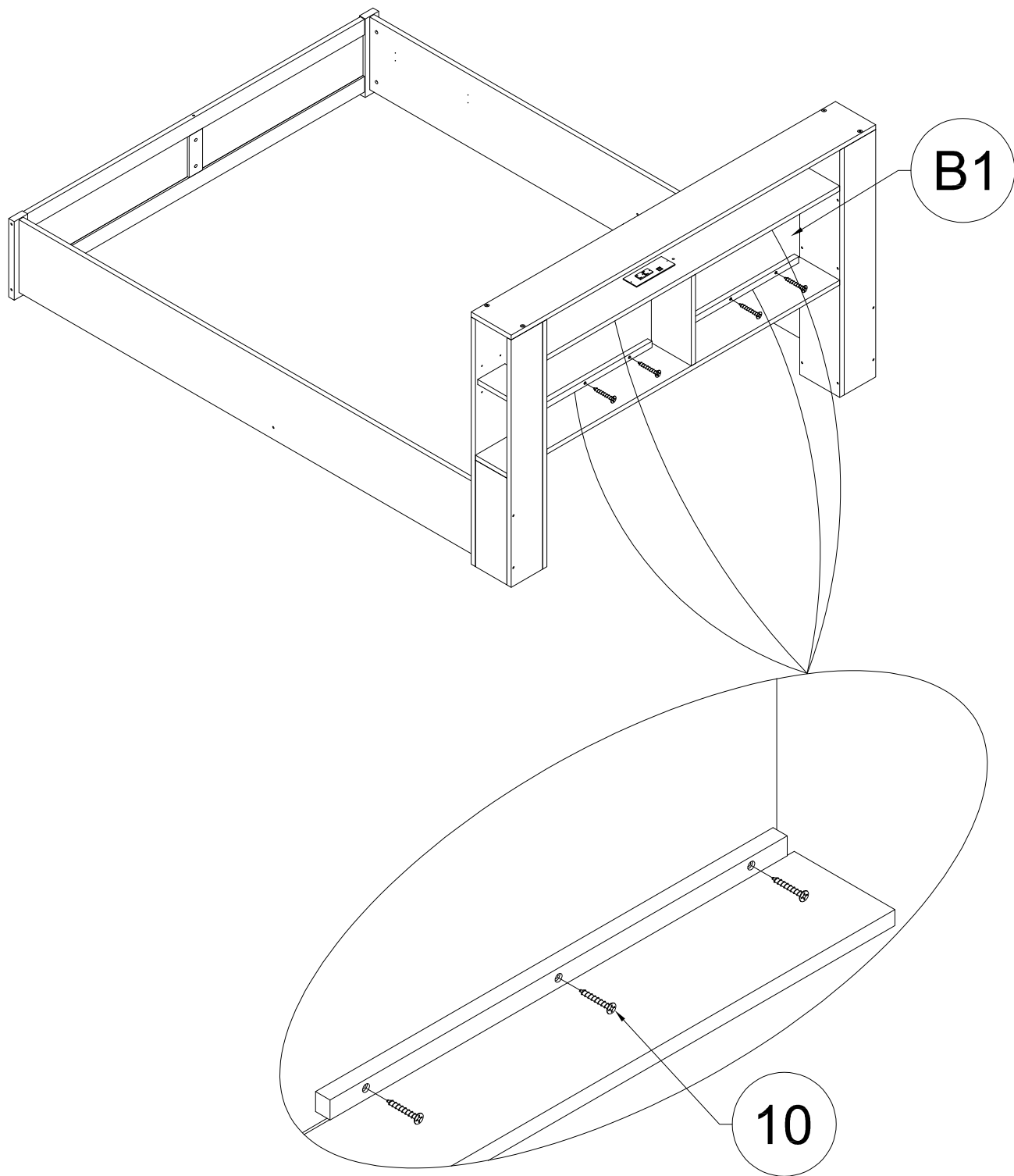

STEP 13: Following below illustration:



12

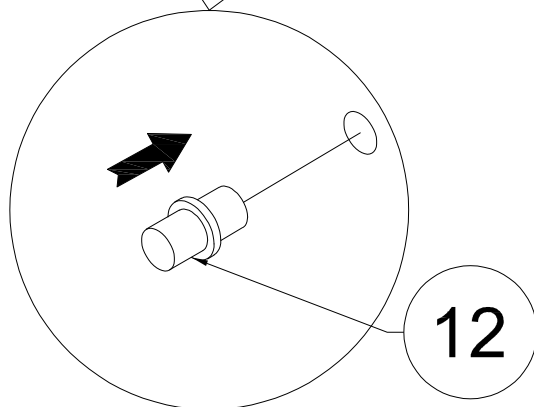
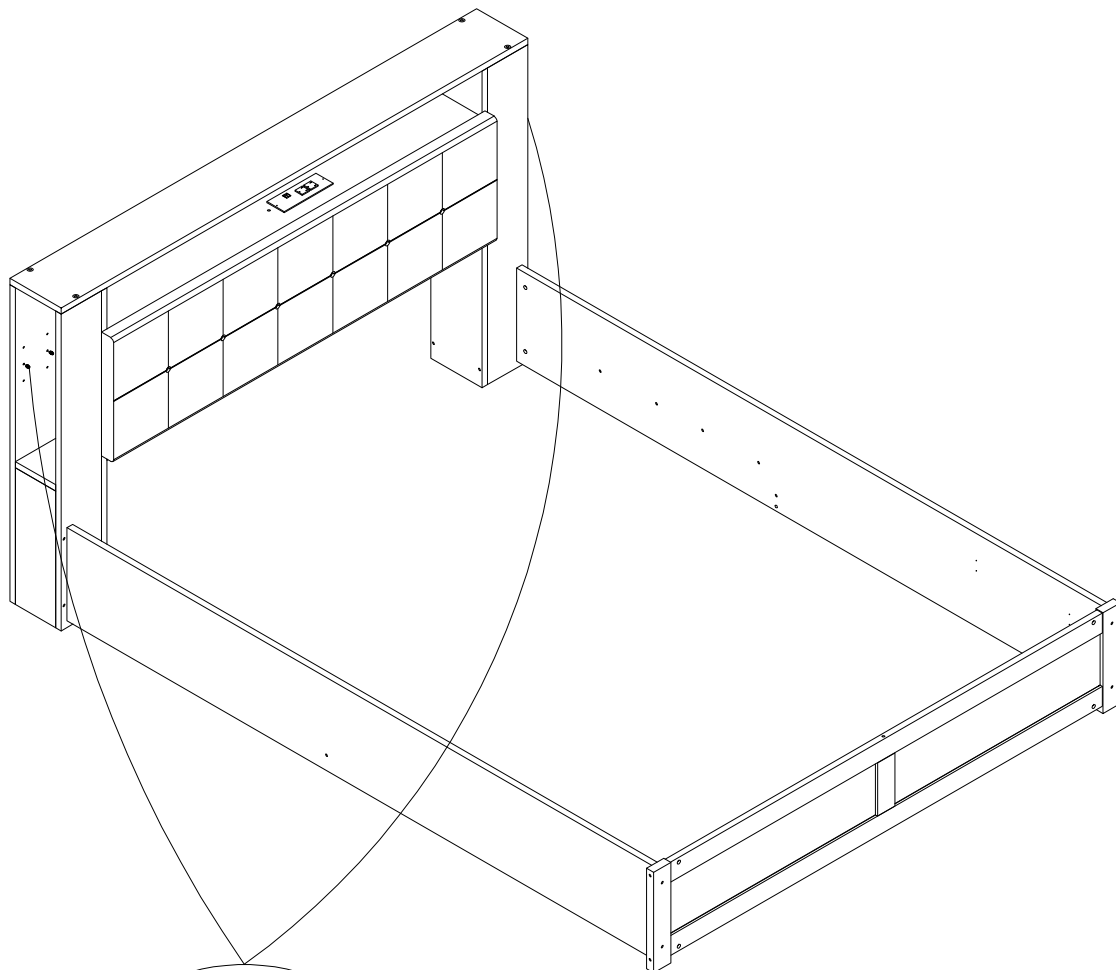

8pcs



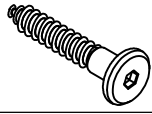

STEP 14: Following below illustration:

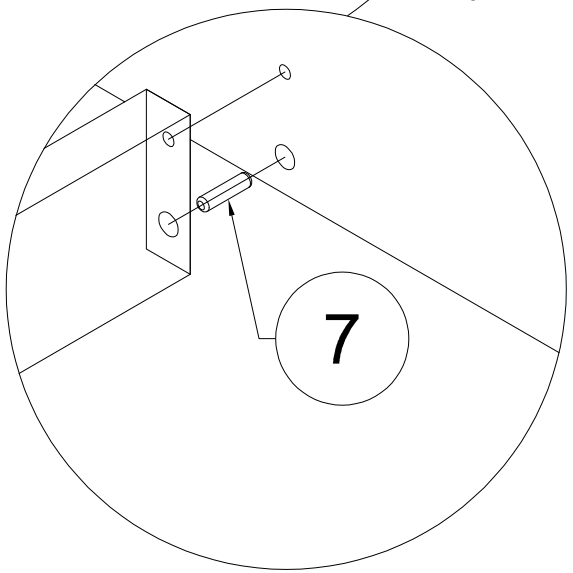
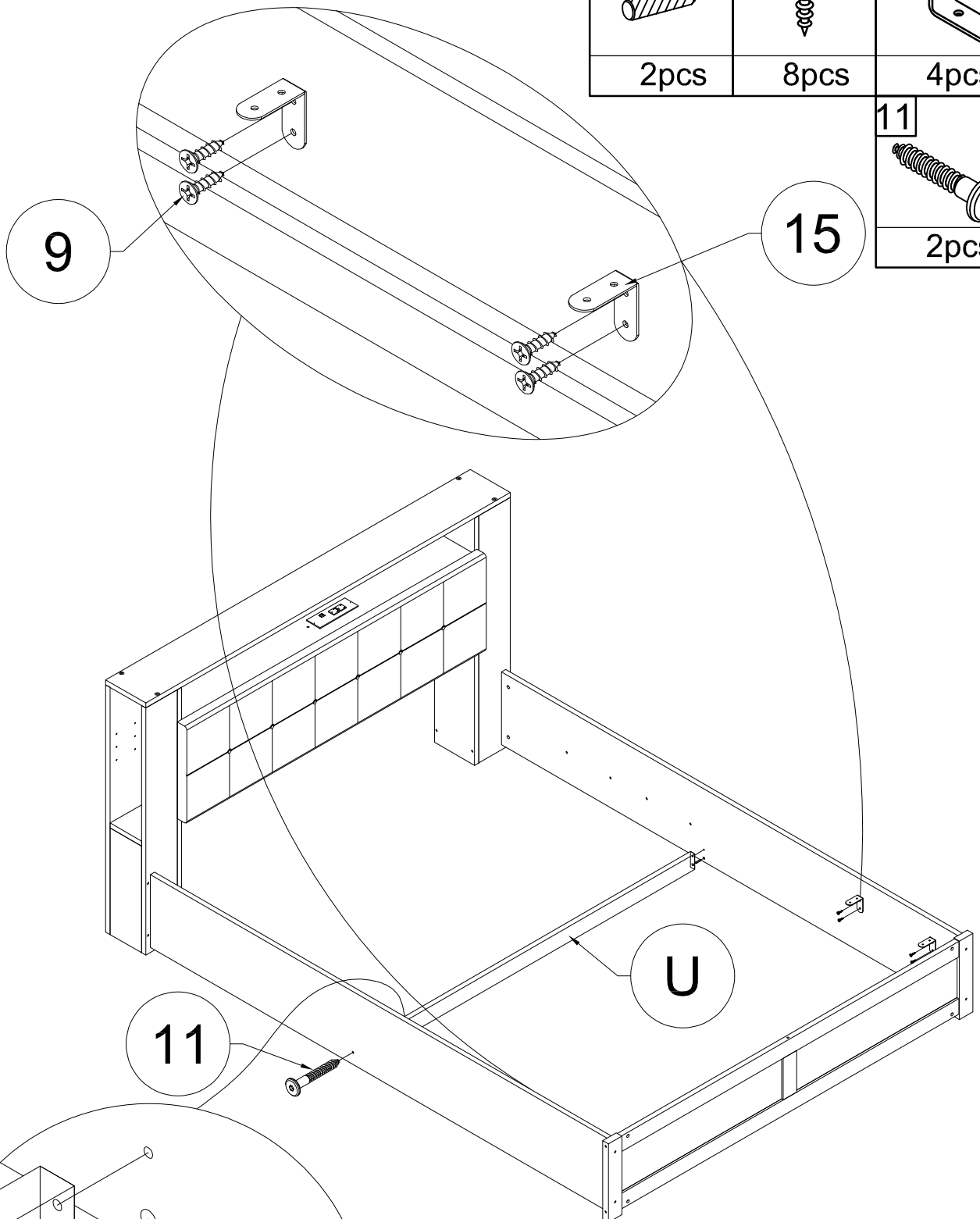
7	9	15
		
2pcs	8pcs	4pcs
		11
		
		2pcs



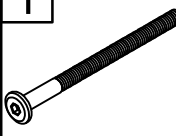

STEP 15: Following below illustration:

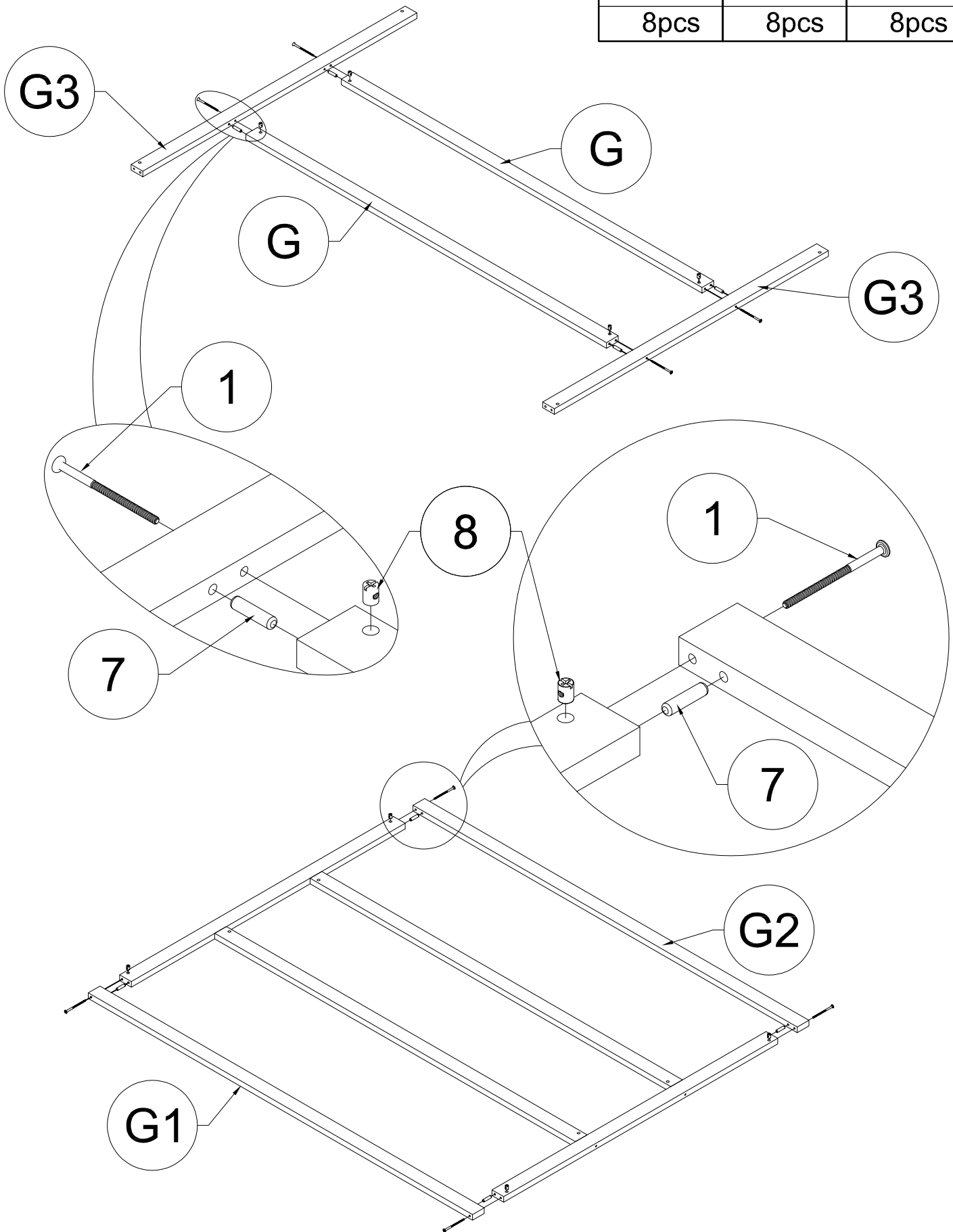
1	7	8
		
8pcs	8pcs	8pcs

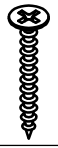

STEP 16: Following below illustration:

4	10	16
		
3pcs	41pcs	1pcs

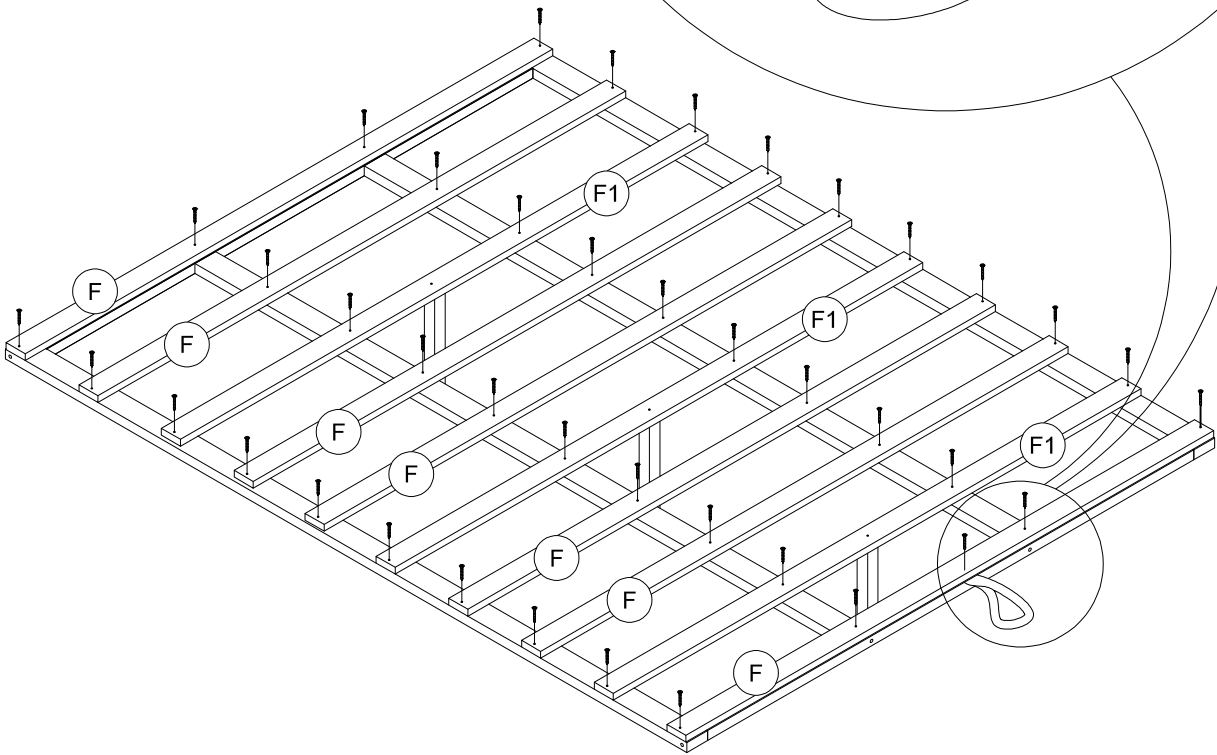
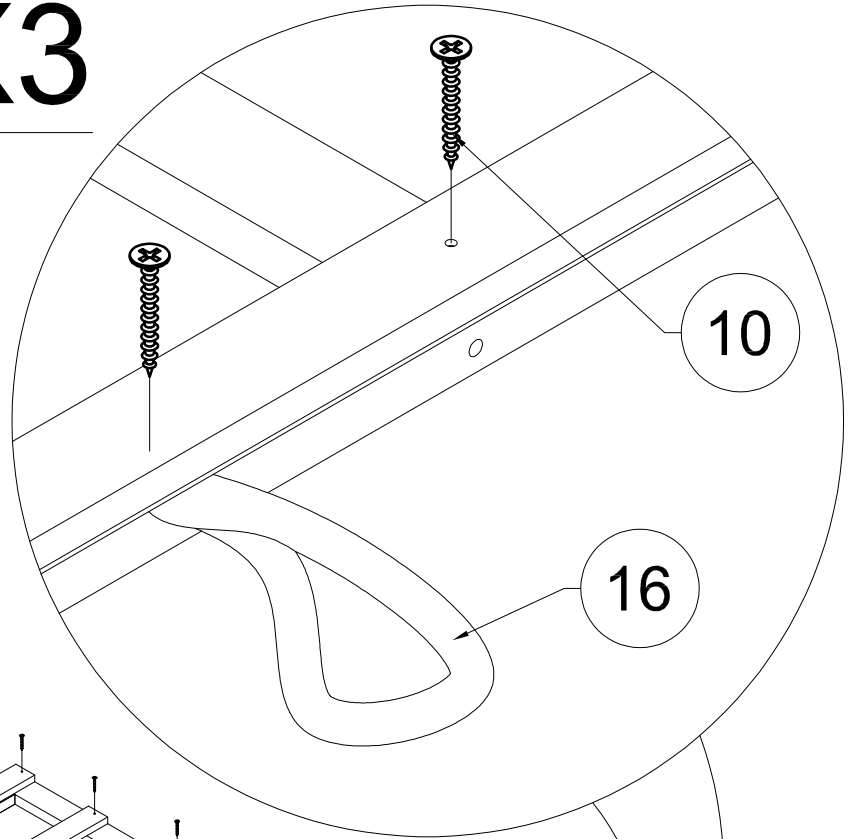
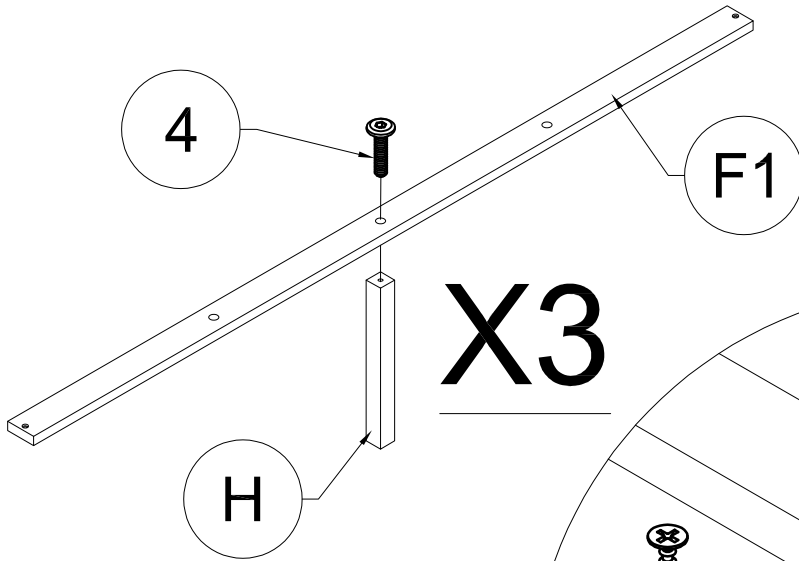

STEP 17: Following below illustration:

6

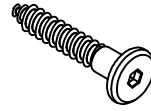

8pcs

13

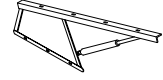

1pcs

14

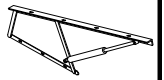

1pcs

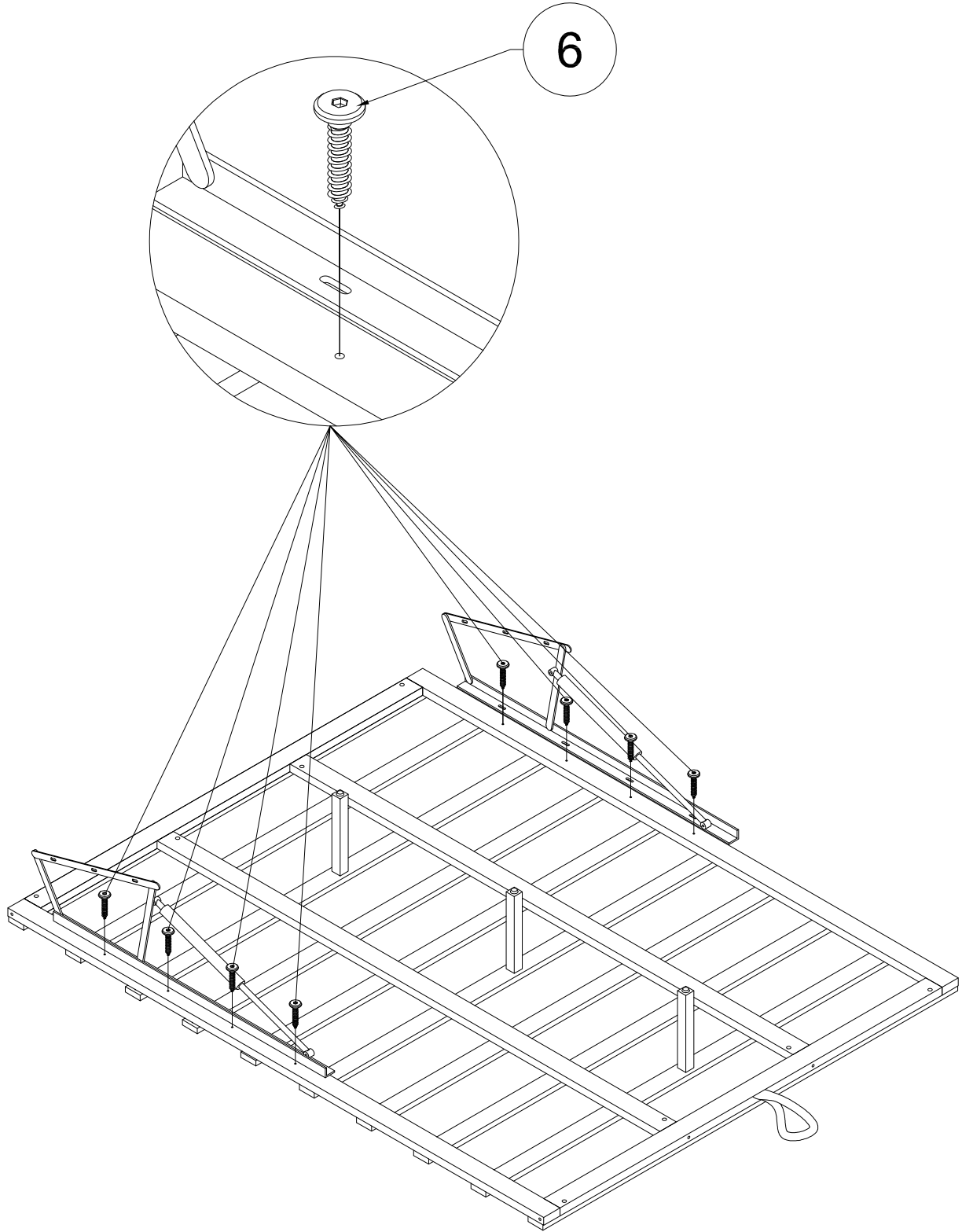

STEP 18: Following below illustration:

5

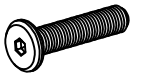

8pcs

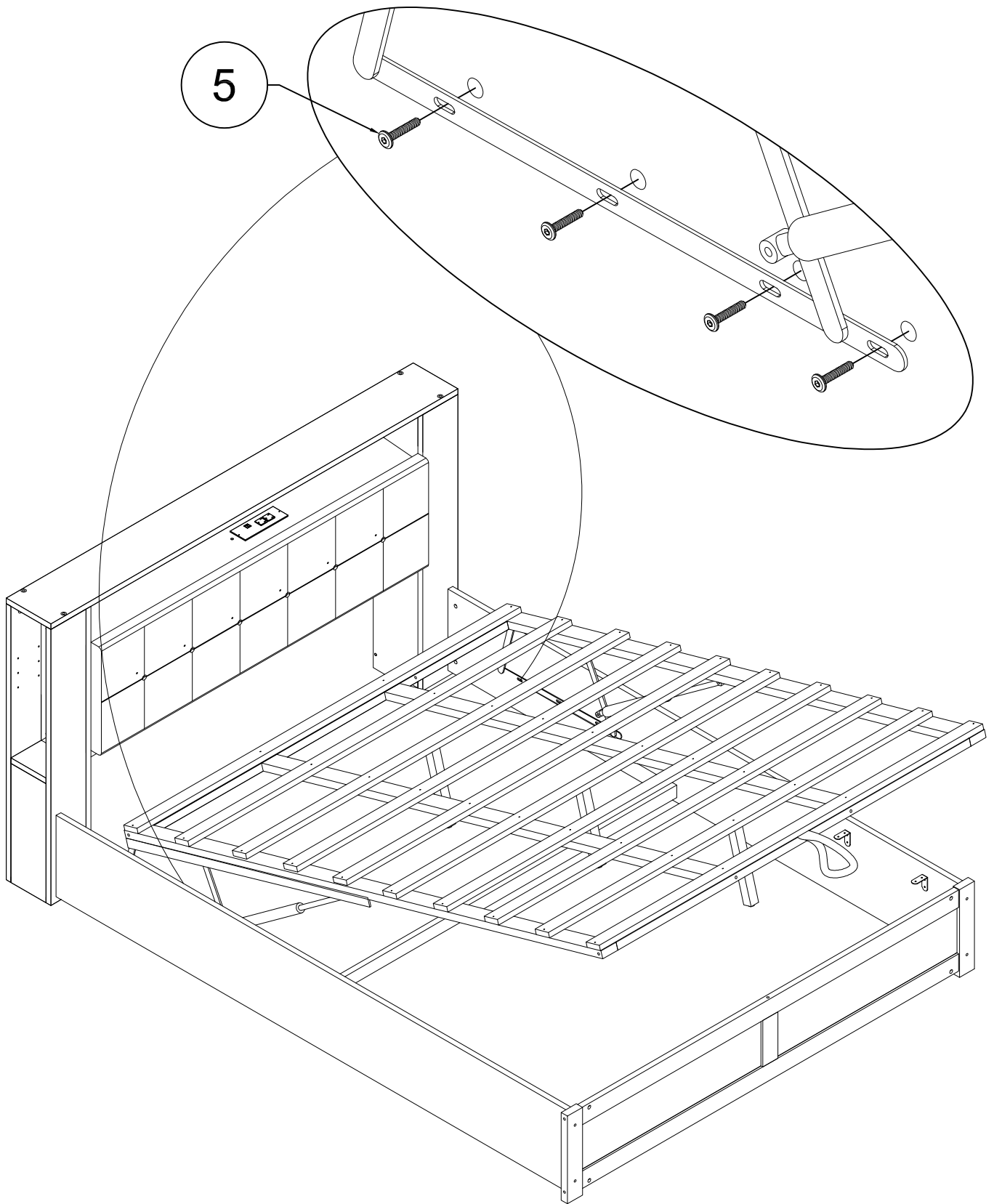

STEP 19: Following below illustration:

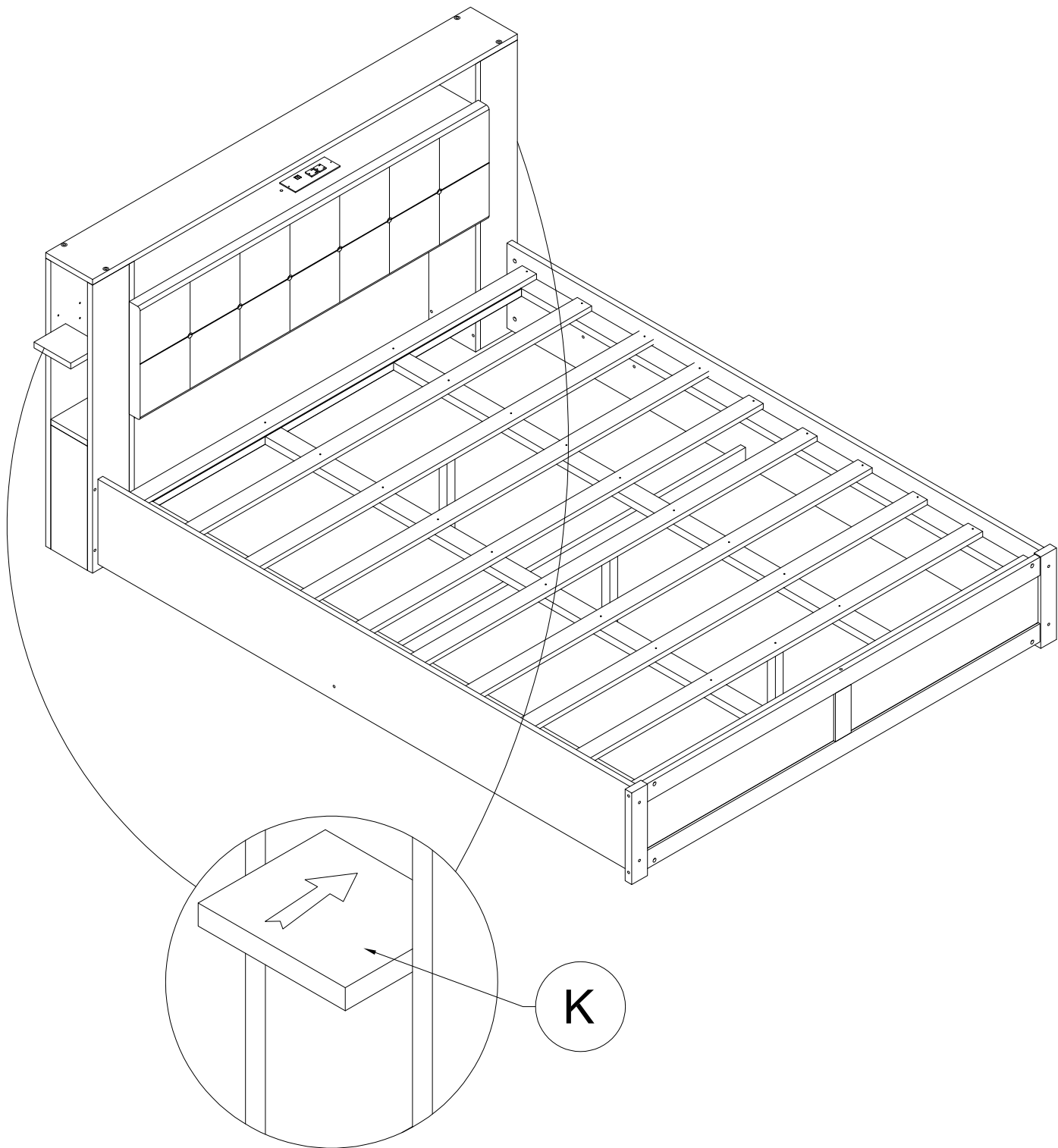

STEP 20: Following below illustration:

9



12pcs

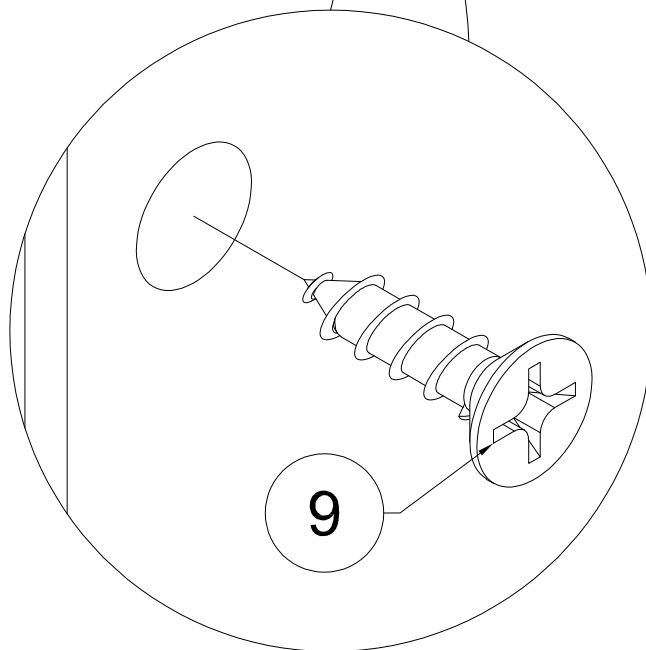
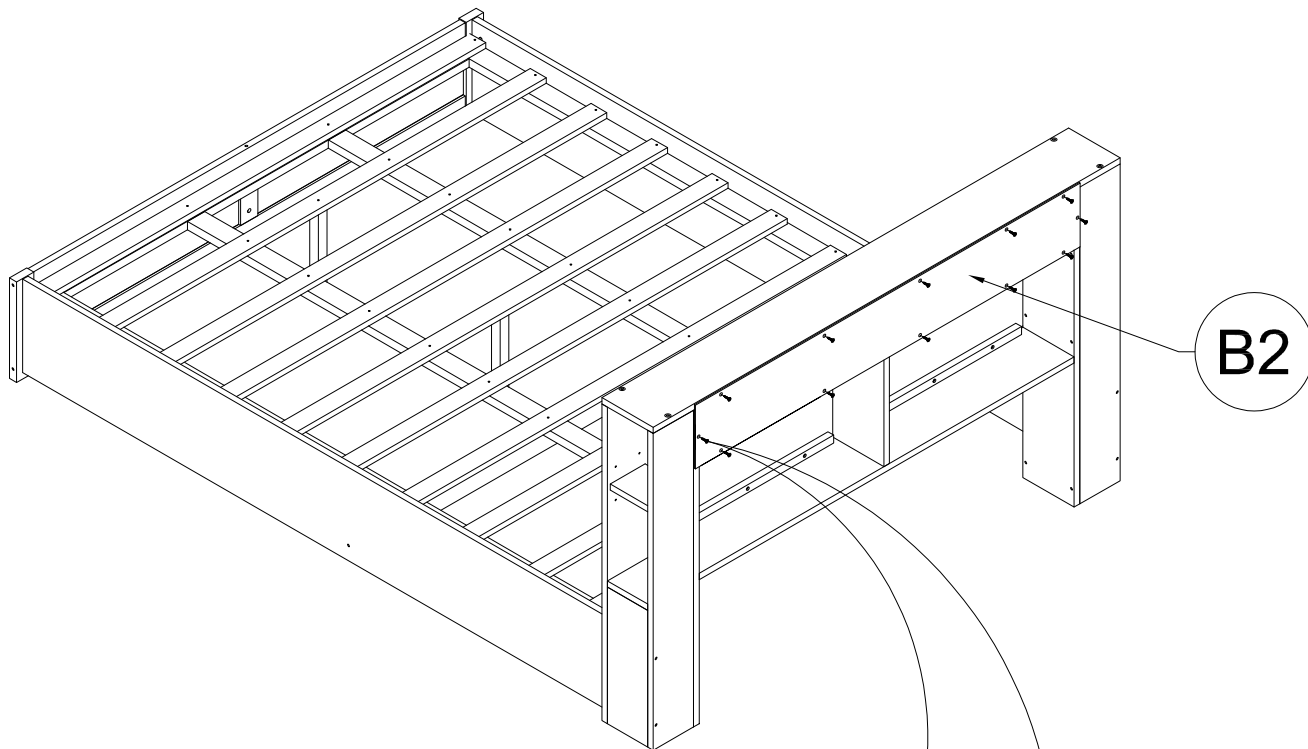

STEP 21: Following below illustration:

17



1pc

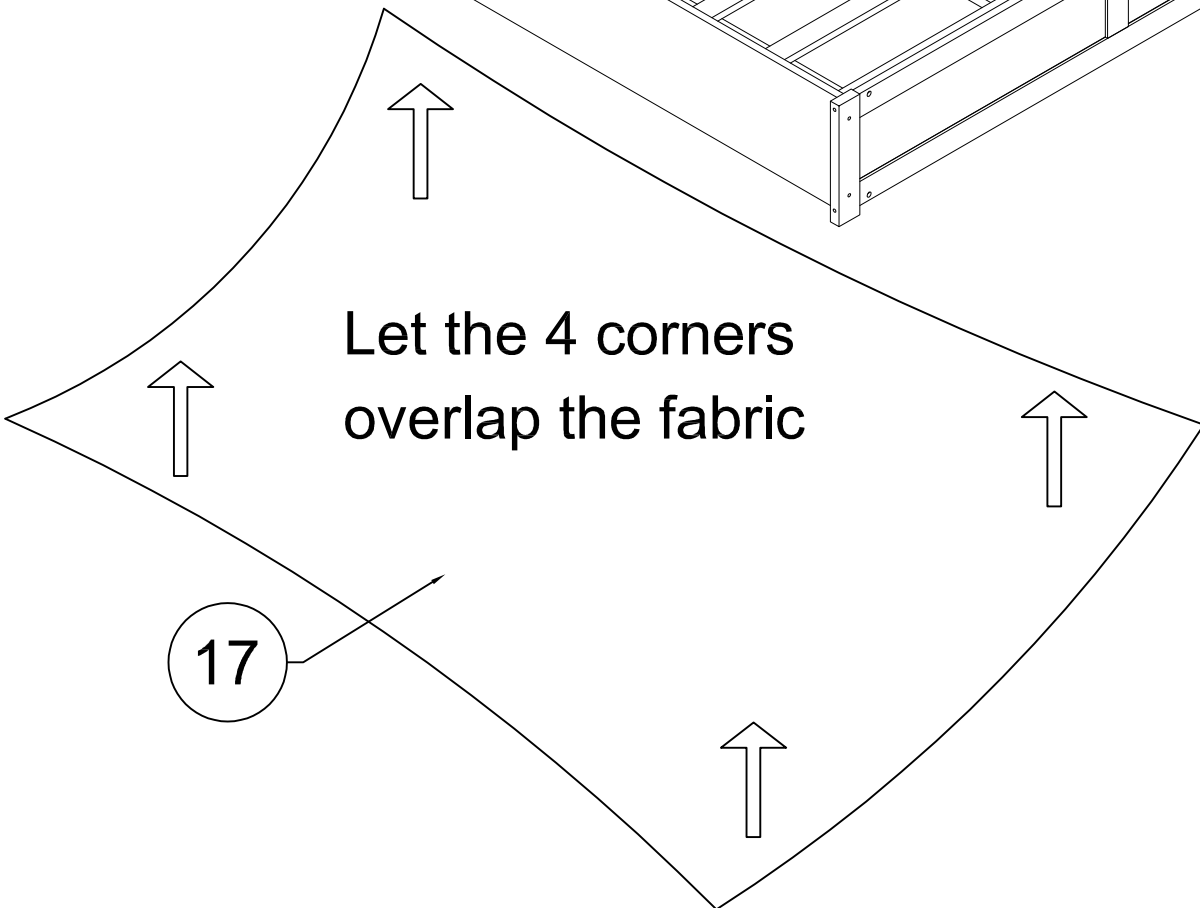
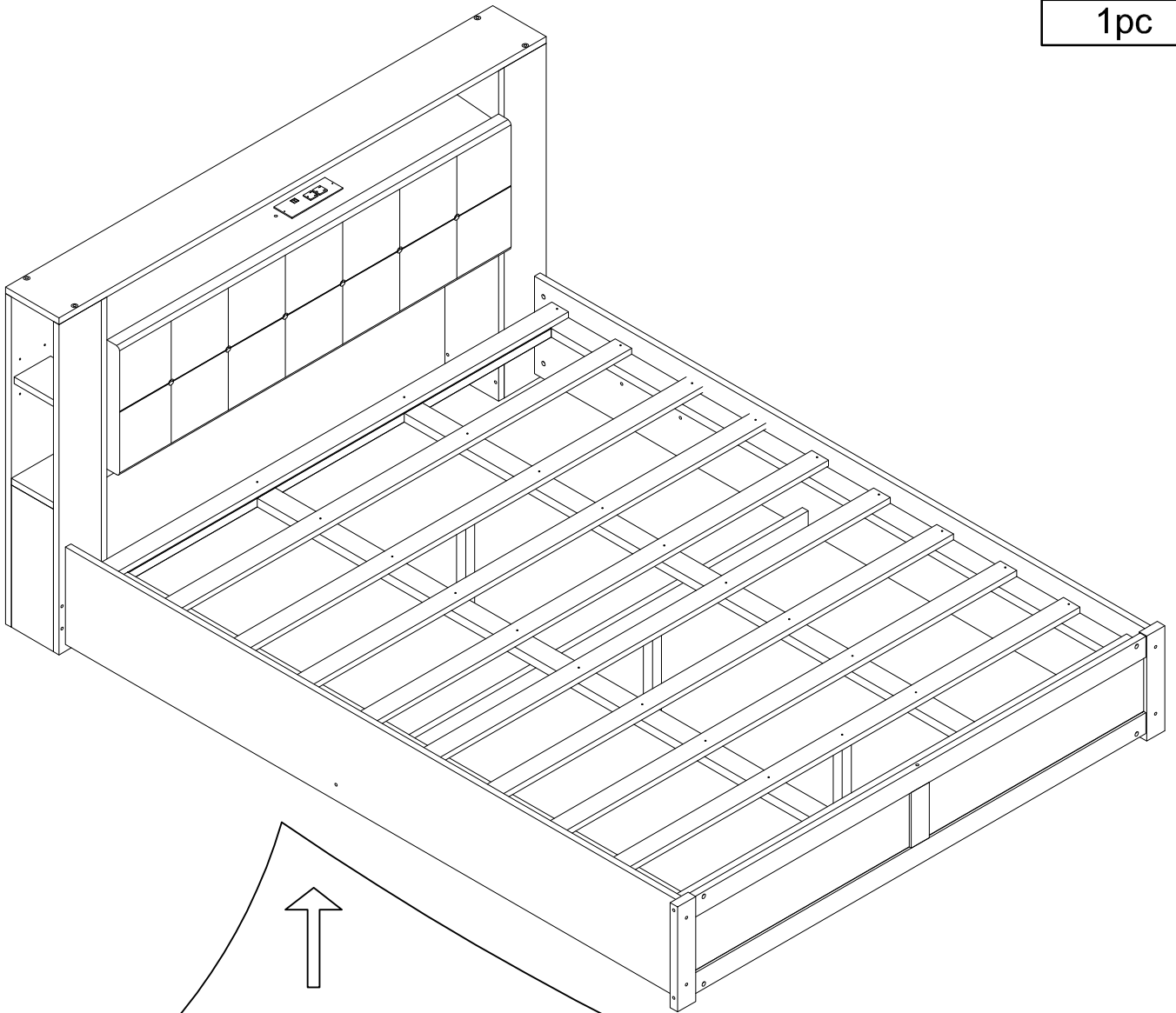

17

26

STEP 22: Following below illustration:

19

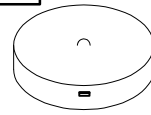

1pc

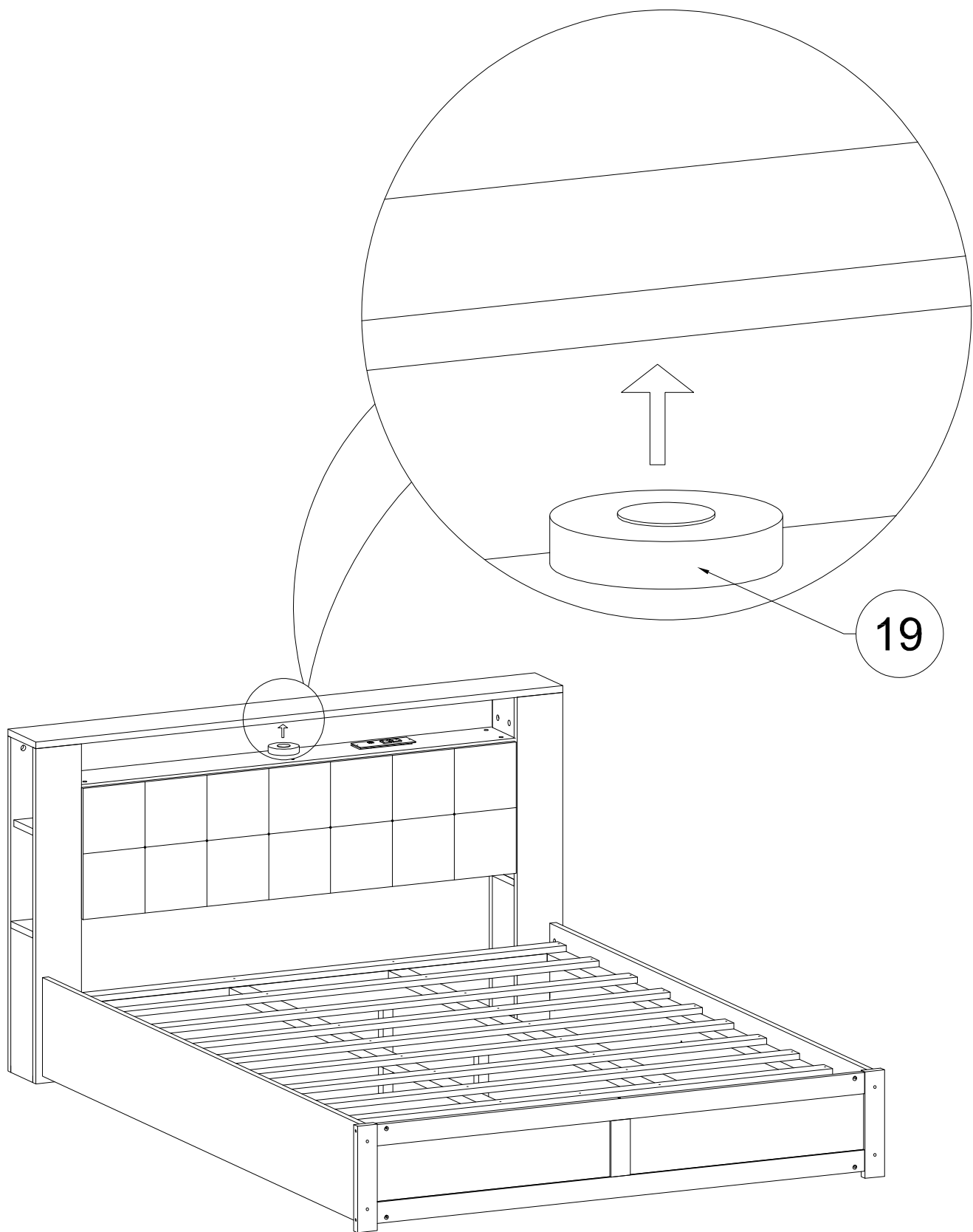

FINISH

