

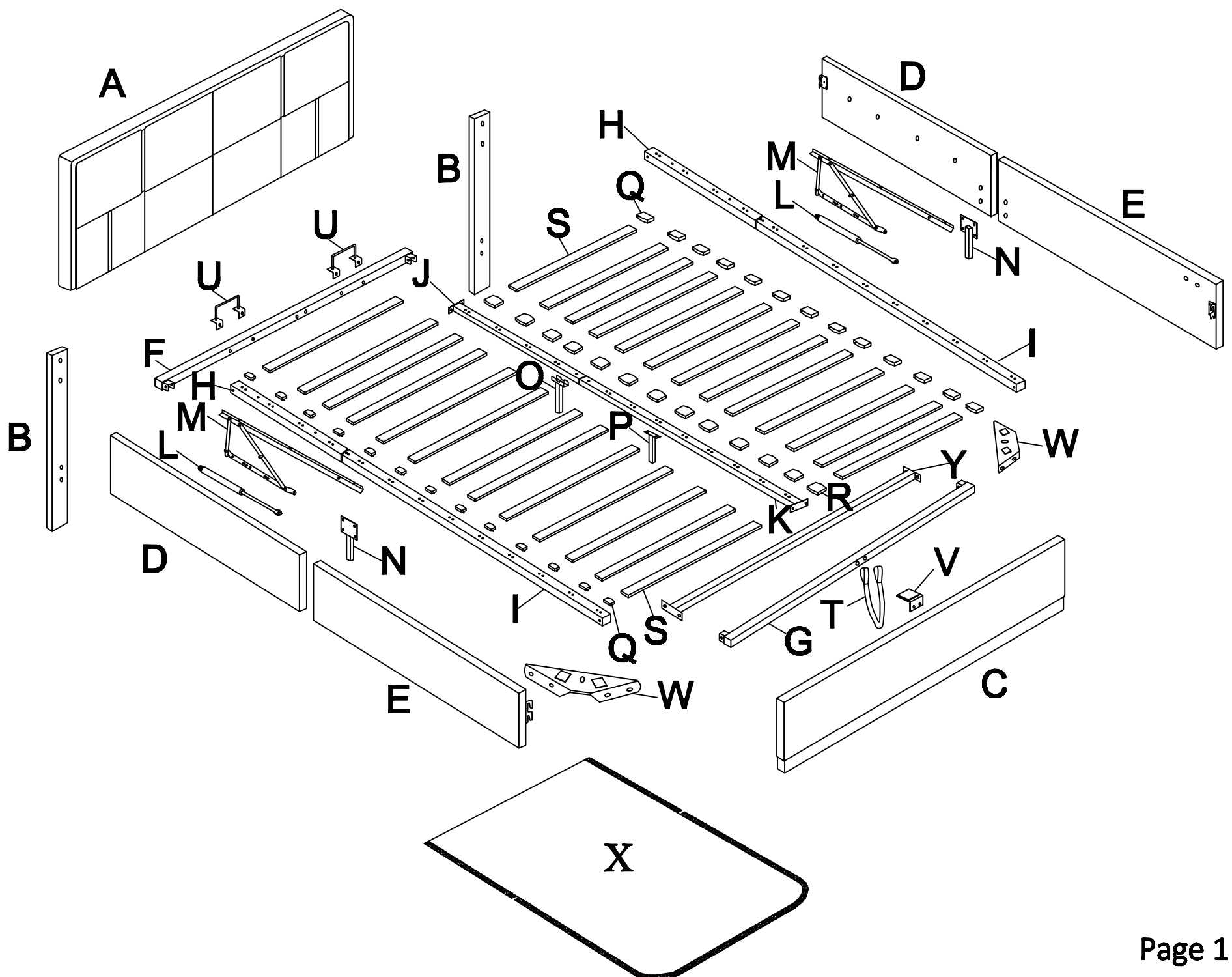

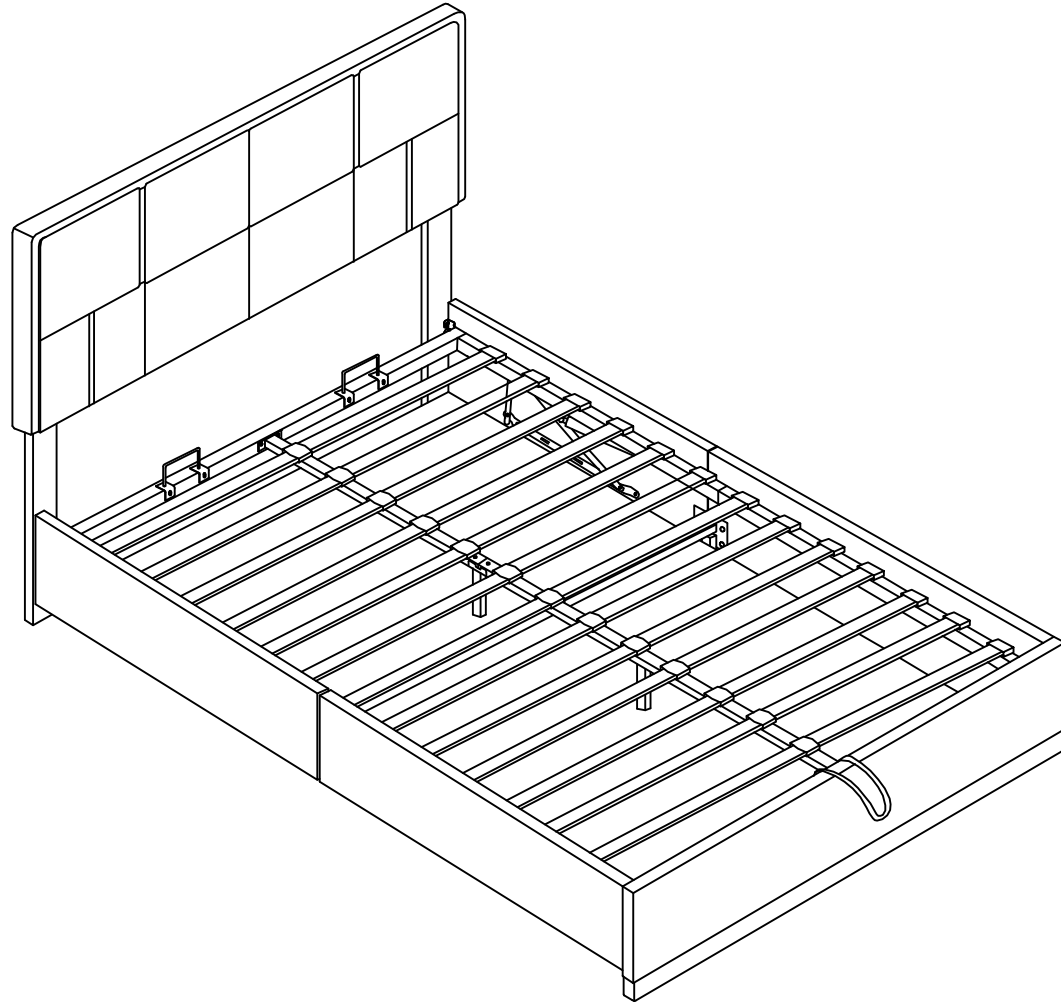

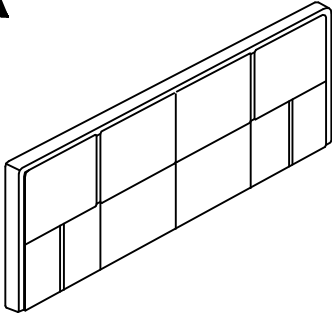

# ASSEMBLY INSTRUCTION

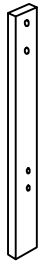
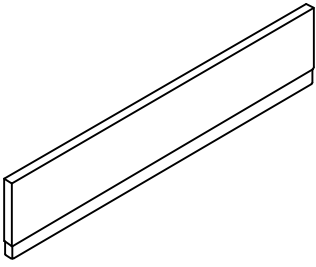
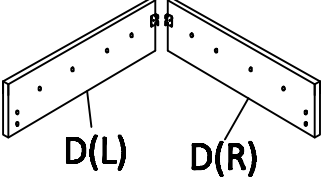
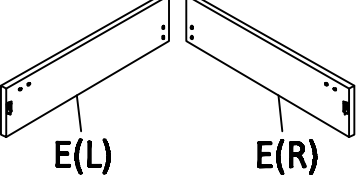
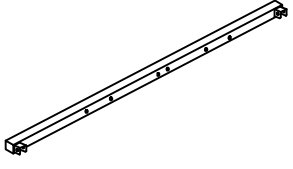
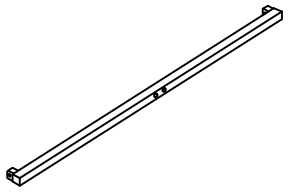
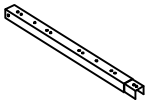
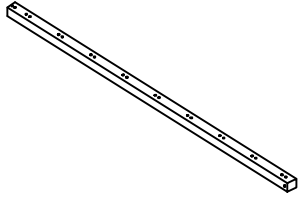
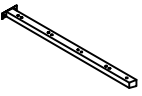
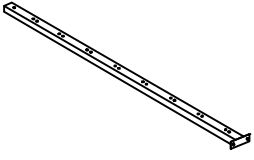
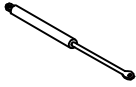
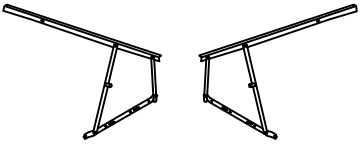
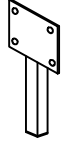
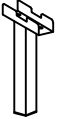
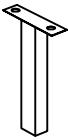

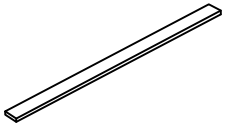

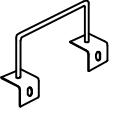

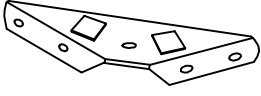
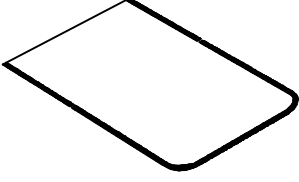
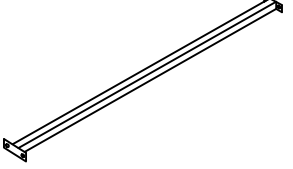
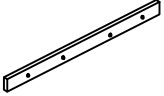

WF310943





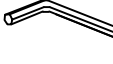

# Parts List

<p><b>A</b></p>  <p>Headboard 1pc</p>	<p><b>B</b></p>  <p>Leg 2pcs</p>	<p><b>C</b></p>  <p>Footboard 1pc</p>	<p><b>D</b></p>  <p>Said Rail 1pair</p>	<p><b>E</b></p>  <p>Said Rail 1pair</p>
<p><b>F</b></p>  <p>Cross Rail for Metal Slat Frame-Headend 1pc</p>	<p><b>G</b></p>  <p>Cross Rail for Metal Slat Frame-Footend 1pc</p>	<p><b>H</b></p>  <p>Metal side 2pcs</p>	<p><b>I</b></p>  <p>Metal side 2pcs</p>	<p><b>J</b></p>  <p>Centre Rail 1pc</p>
<p><b>K</b></p>  <p>Centre Rail 1pc</p>	<p><b>L</b></p>  <p>Gas Lift 2pcs</p>	<p><b>M</b></p>  <p>Gas Lift Mechanism 1pair</p>	<p><b>N</b></p>  <p>Said Rail Support Leg 2pcs</p>	<p><b>O</b></p>  <p>Centre Support Leg 1pc</p>
<p><b>P</b></p>  <p>Centre Support Leg 1pc</p>	<p><b>Q</b></p>  <p>Slat Cap 24pcs</p>	<p><b>R</b></p>  <p>Double plastic cap 12pcs</p>	<p><b>S</b></p>  <p>Slat 24pcs</p>	<p><b>T</b></p>  <p>Fabric handle 1pc</p>
<p><b>U</b></p>  <p>Mattress Stopper 2pcs</p>	<p><b>V</b></p>  <p>Angle Iron 1pc</p>	<p><b>W</b></p>  <p>Metal Corner Bracket 2pcs</p>	<p><b>X</b></p>  <p>Bottom cloth 1pc</p>	<p><b>Y</b></p>  <p>Reinforced Pipe 1pc</p>
<p><b>Z</b></p>  <p>Supporting block on SR 2pcs</p>				

# Hardware List



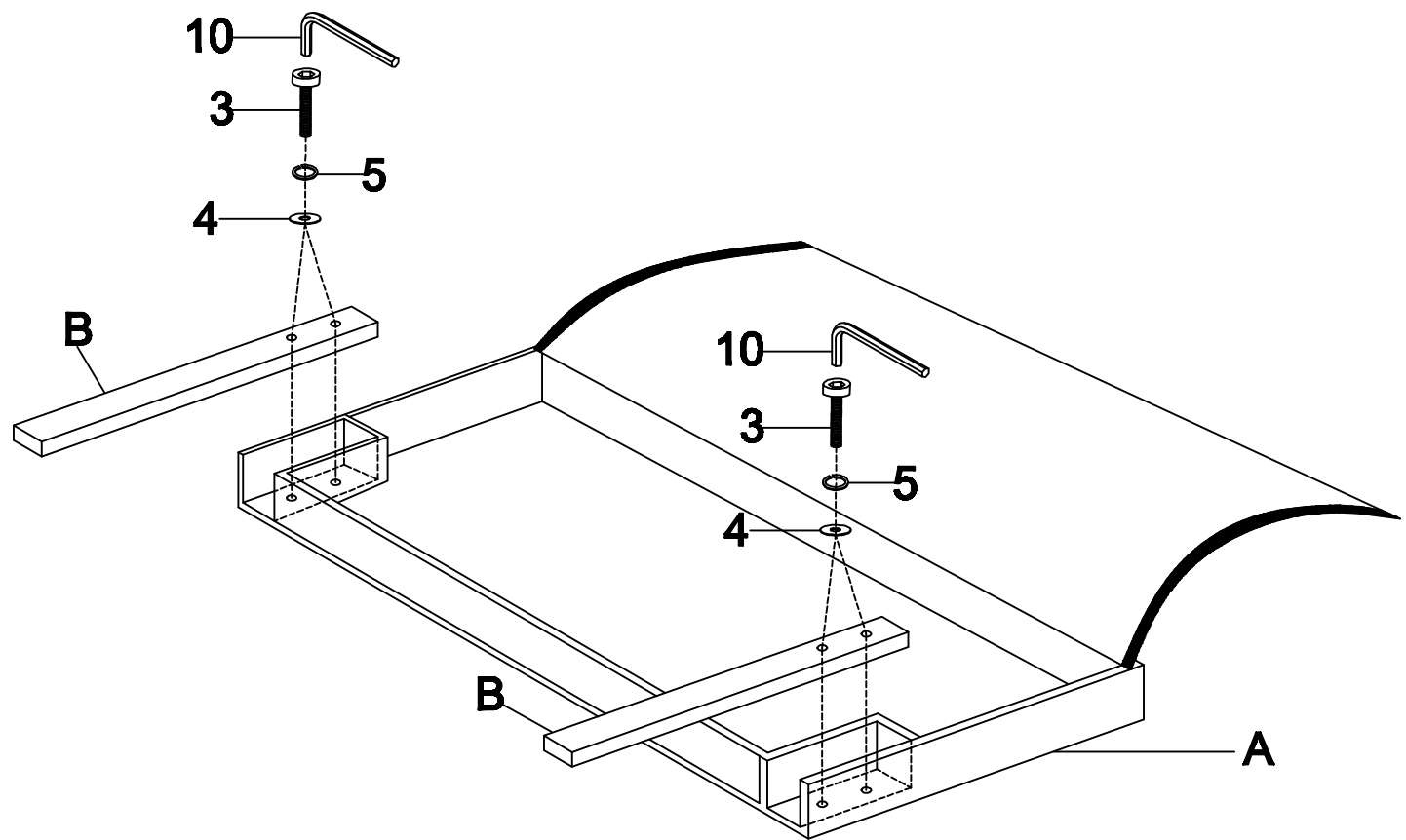

<b>1: Bolt 30pcs</b>  M8*20mm	<b>2: Bolt 8pcs</b>  M8*25mm	<b>3: Bolt 28pcs</b>  M8*50mm	<b>4: Flat Washer 88pcs</b>  Ø19mm	<b>5: Spring Washer 66pcs</b>  M8*1.2mm
<b>6: Nut 22pcs</b>  M8*12mm	<b>7: Nut 4pcs</b>  M8*13mm	<b>8: Spanner 1pc</b>  12mm	<b>9: Spanner 1pc</b>  13mm	<b>10: Allen Key 1pc</b>  M5

## STEP 1:

- 3  x4
- 4  x4
- 5  x4
- 10  x1



## STEP 2:

- 1  x6
- 4  x6
- 5  x6
- 10  x1

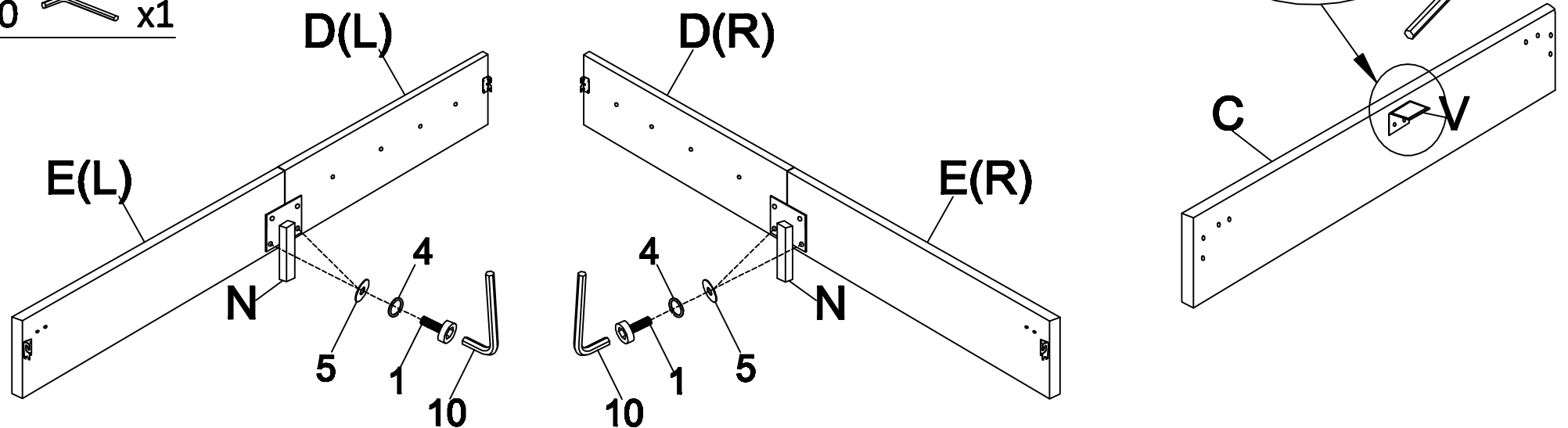

**STEP 3:**

1  x8

4  x8

5  x8

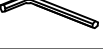
10  x1

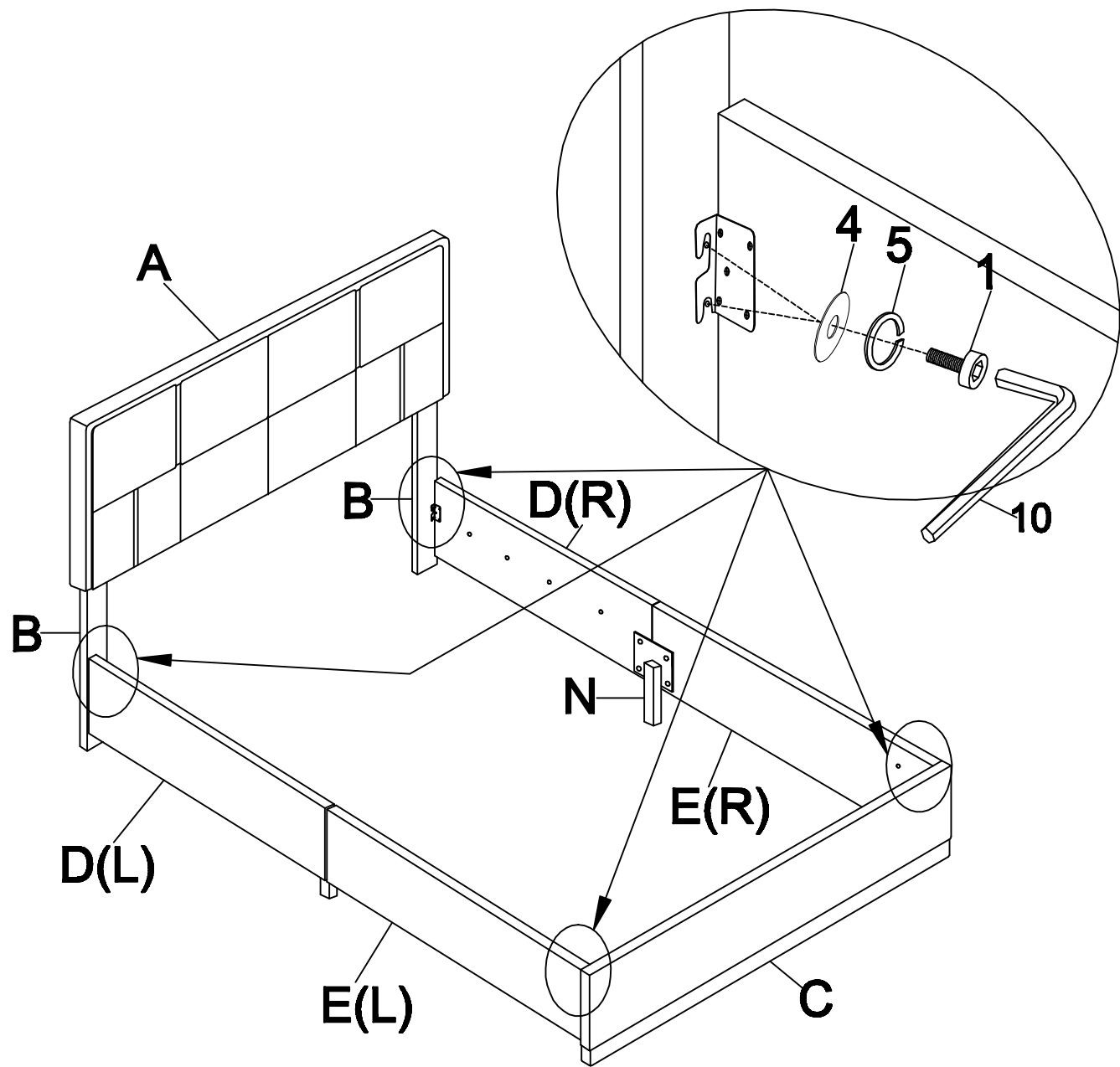

**STEP 4:**

1  x12

4  x12

5  x12

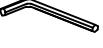
10  x1

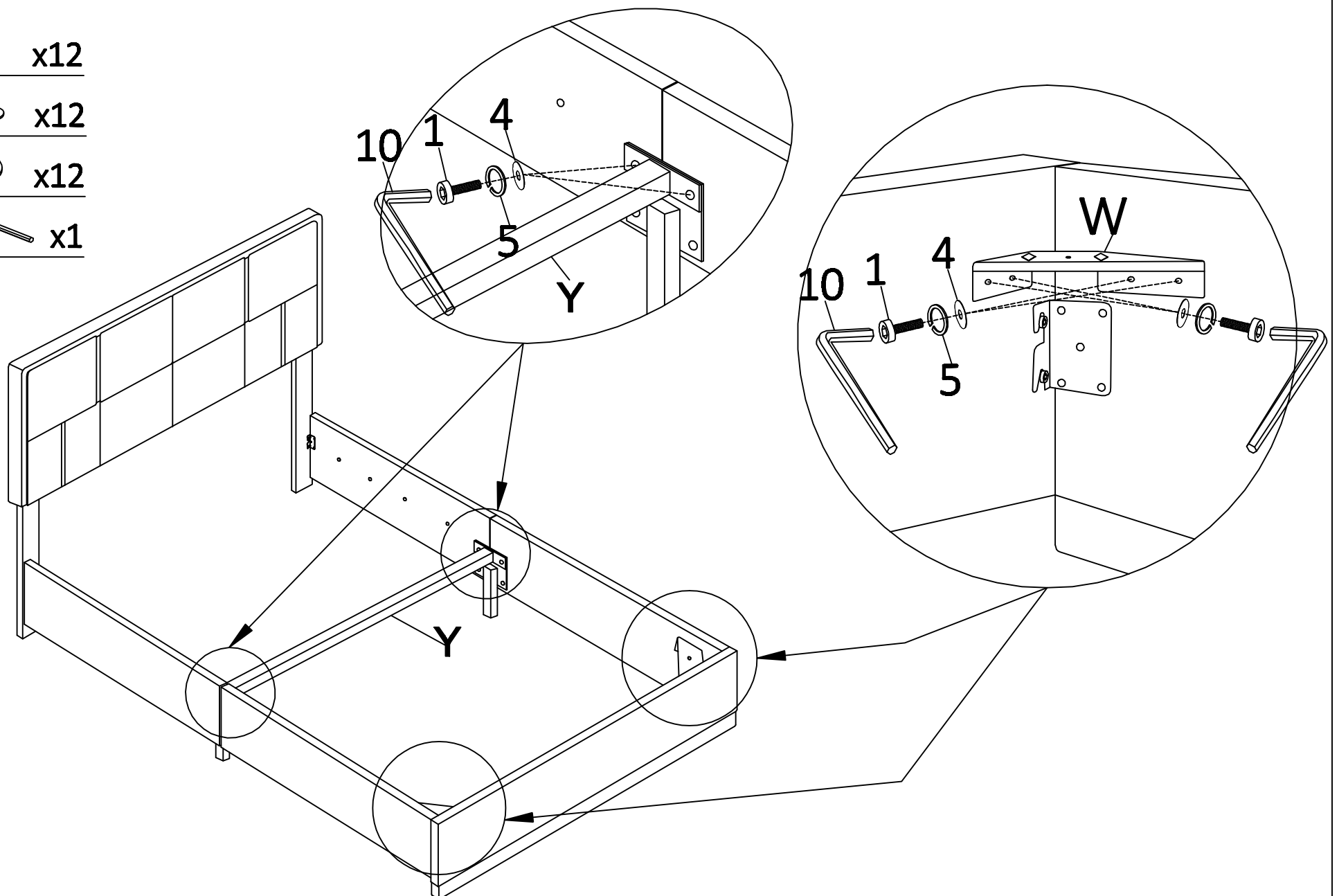

**STEP 5:**

7  X4

9  X1

L  X2

M  X2

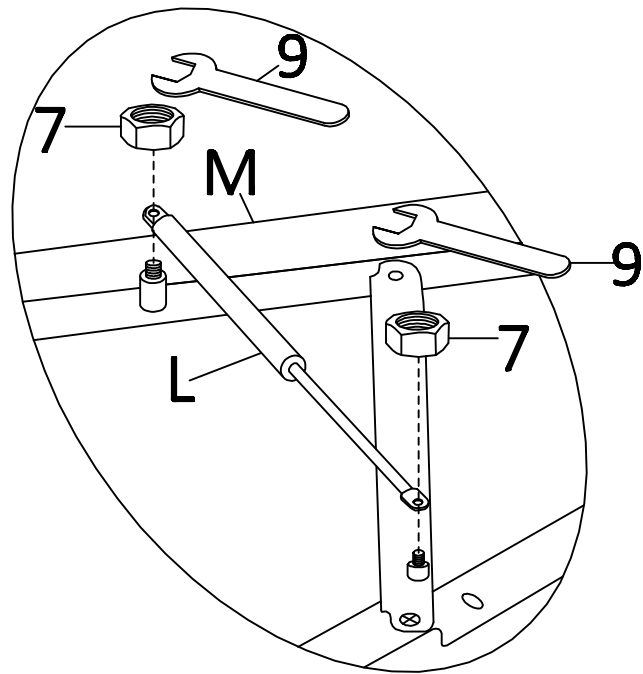
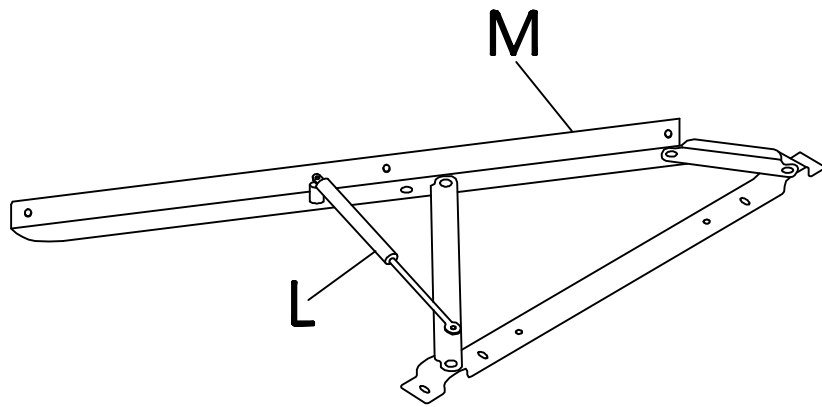



**STEP 6:**

2  x8

4  x8

5  x8

10  x1

0  x2

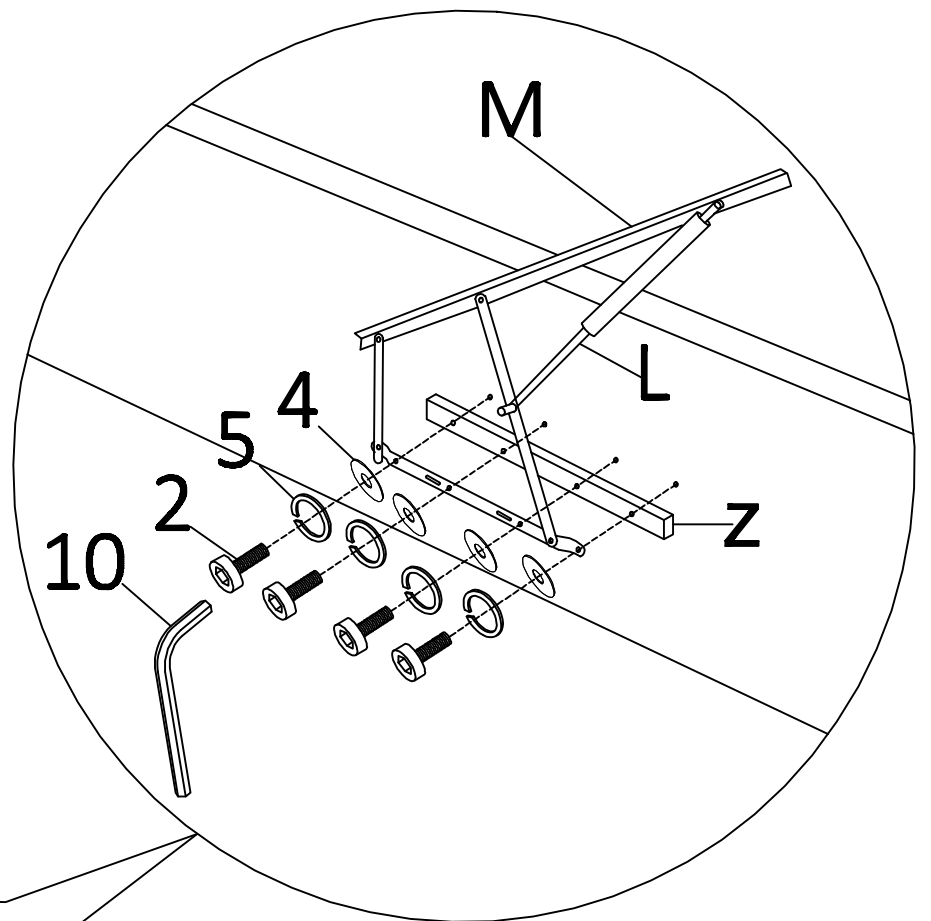
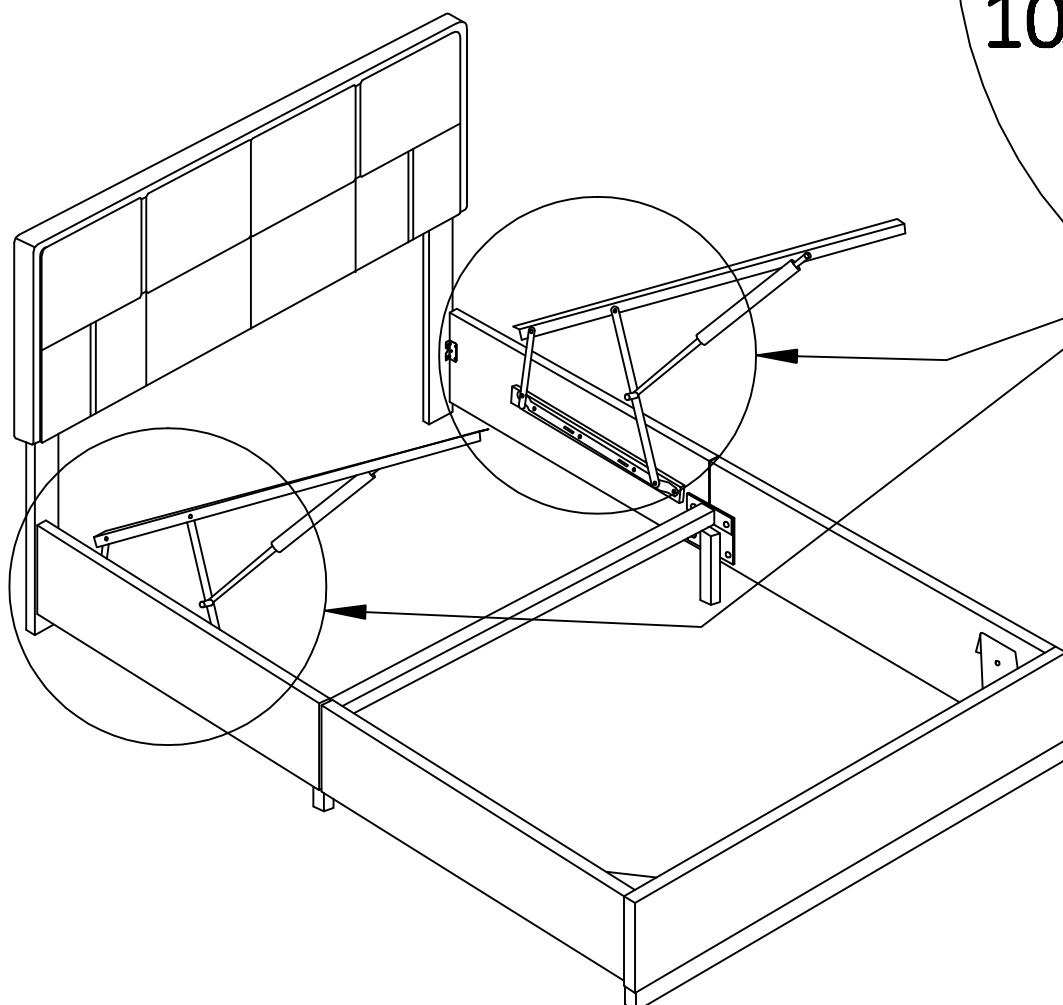

**STEP 7:**

1  x4

3  x4

4  x10

5  x8

10  x1

6  x2

8  x1

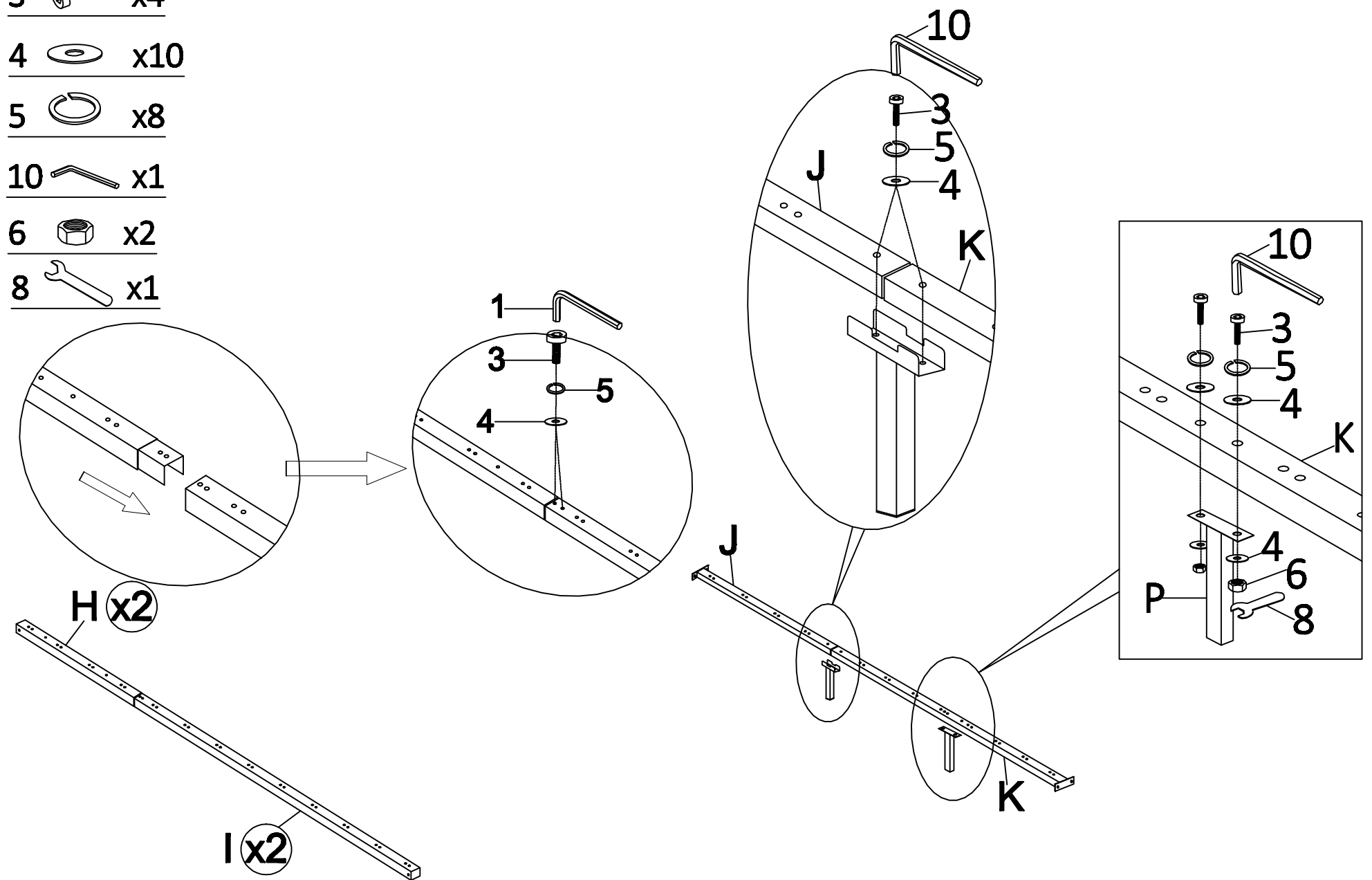



**STEP 8:**

3  x4

4  x8

5  x4

10  x1

6  x4

8  x1

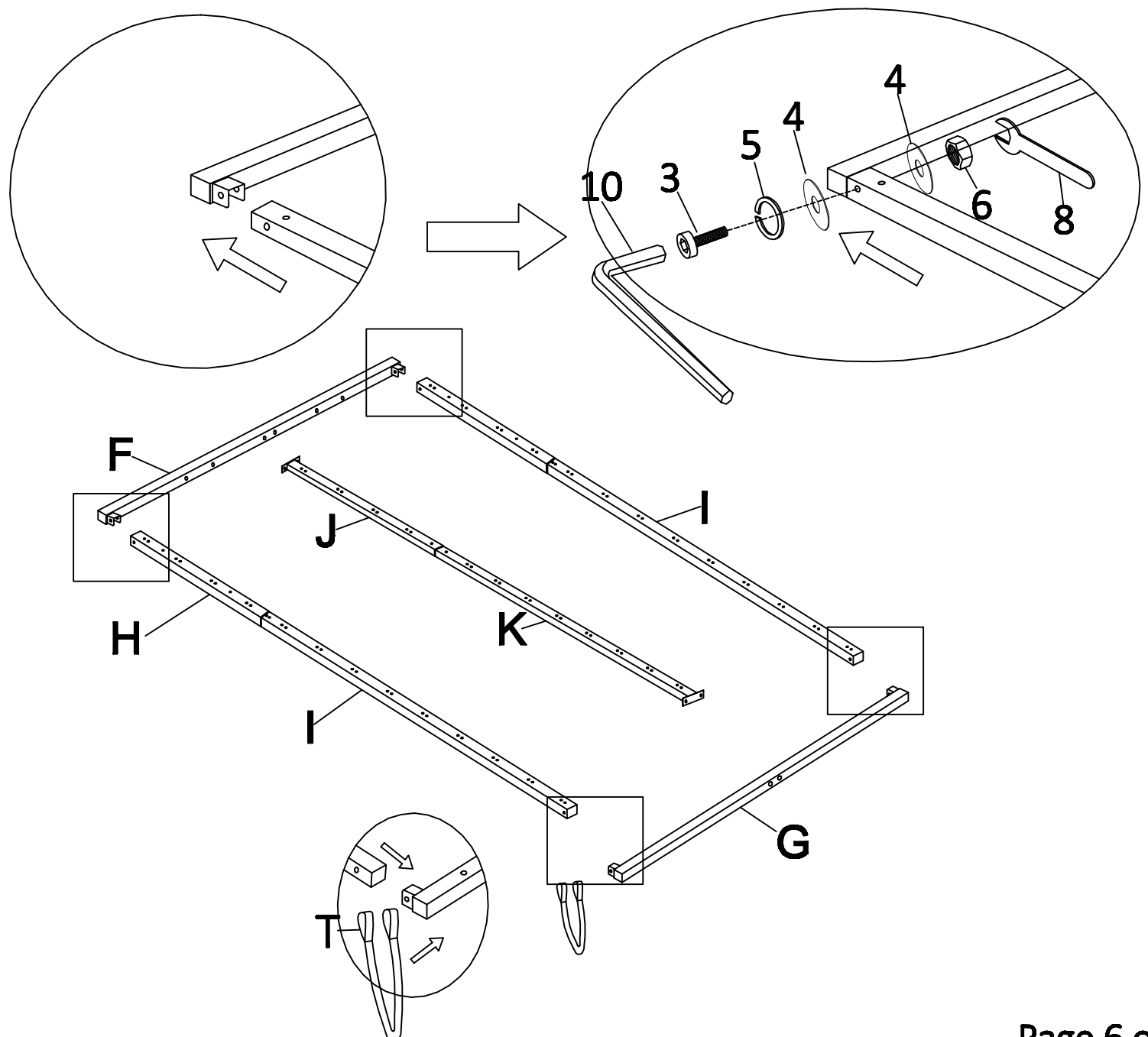



**STEP 9:**

3  x8

4  x16

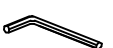
5  x8

10  x1

6  x8

8  x1

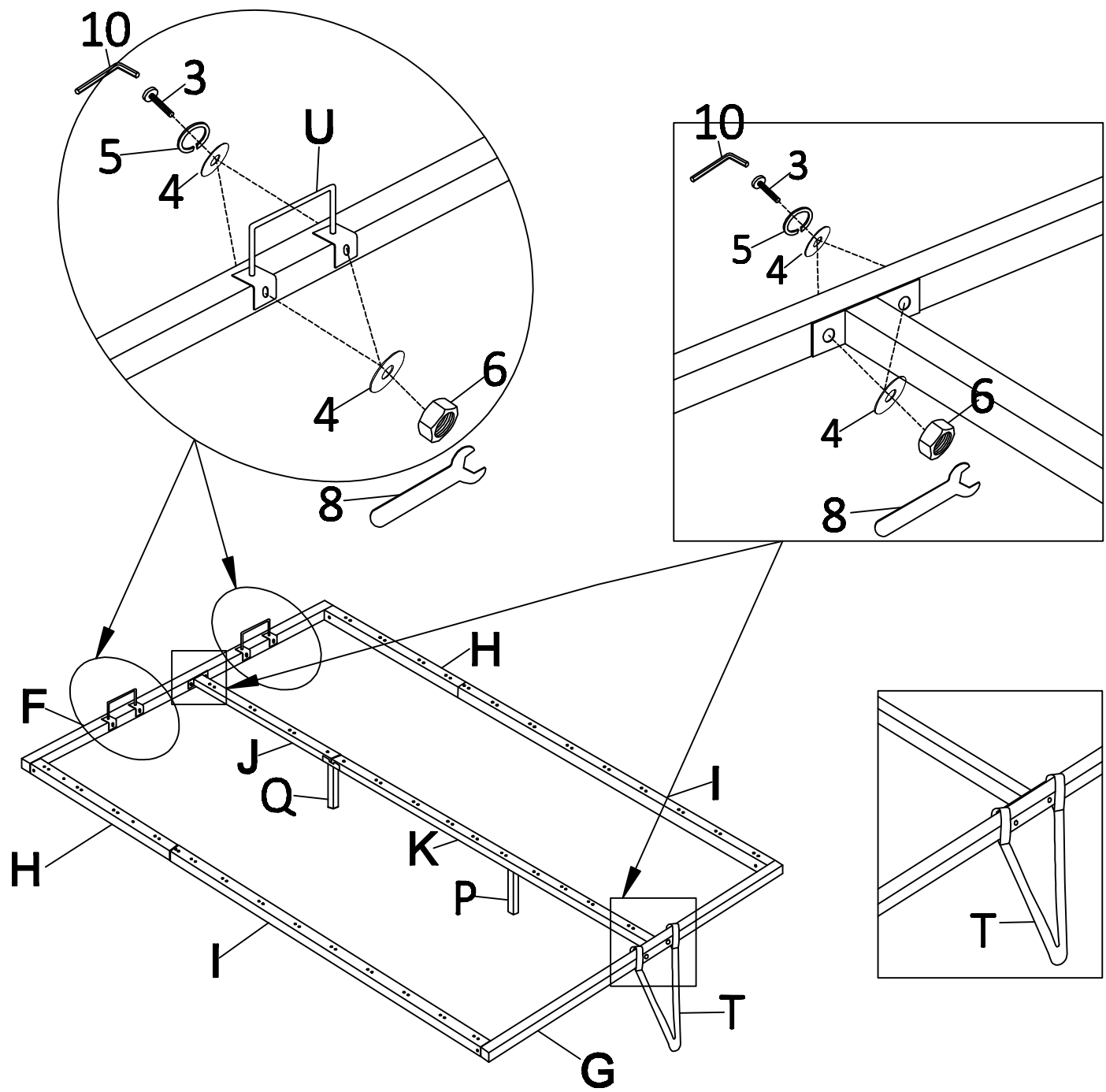

**STEP 10:**

3  x8

4  x16

5  x8

10  x1

6  x8

8  x1

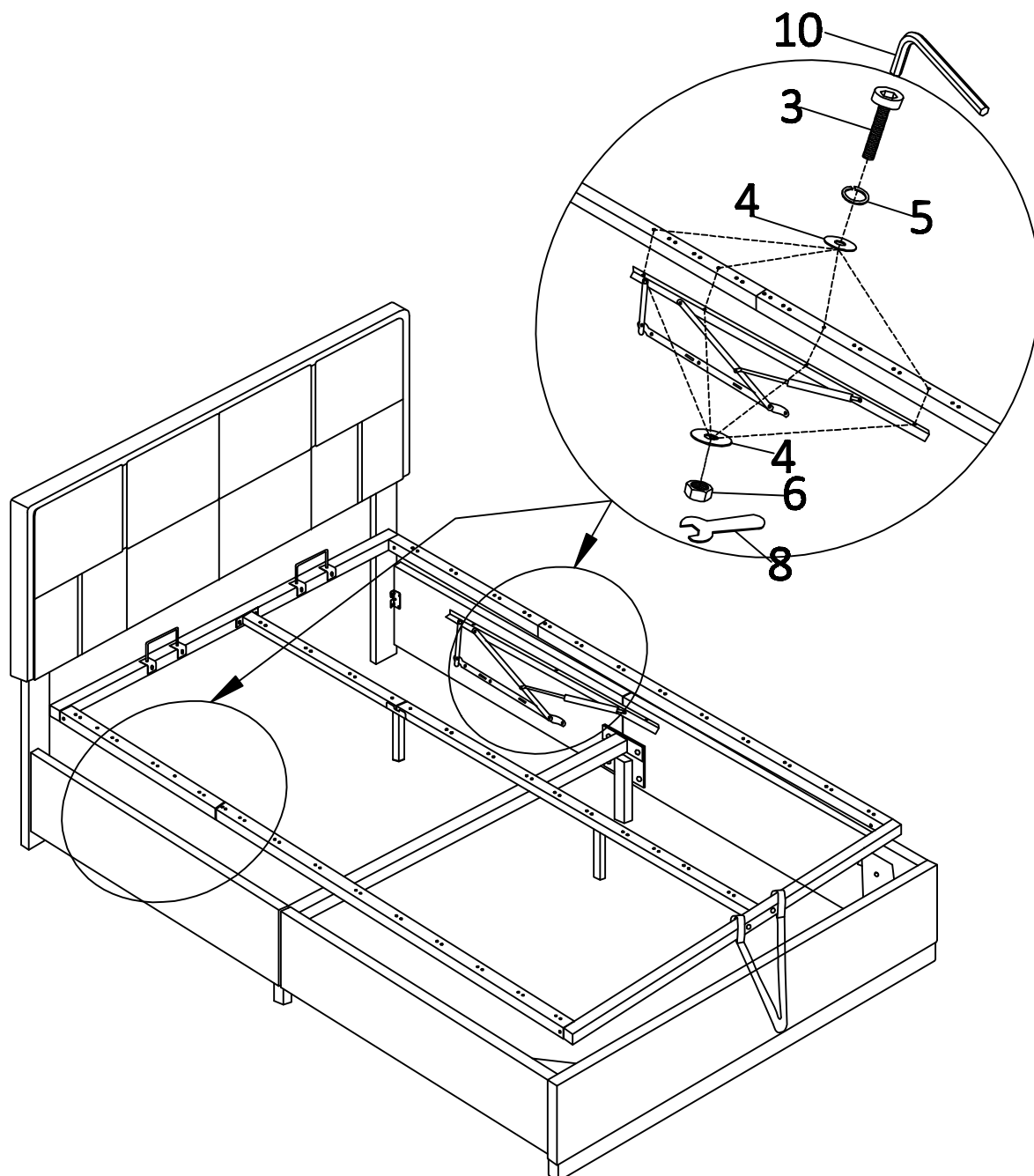

**STEP 11:**

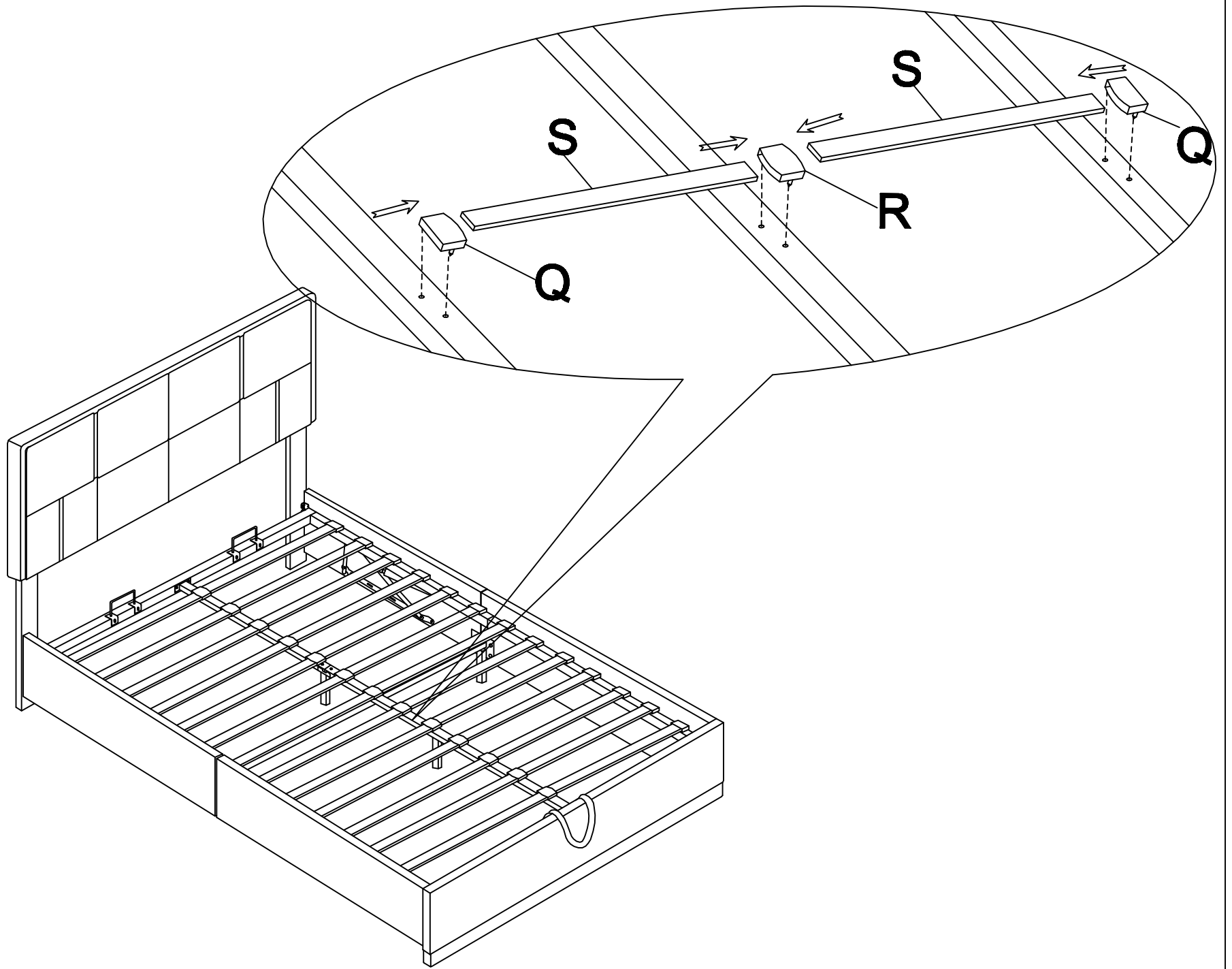

**STEP 12:**

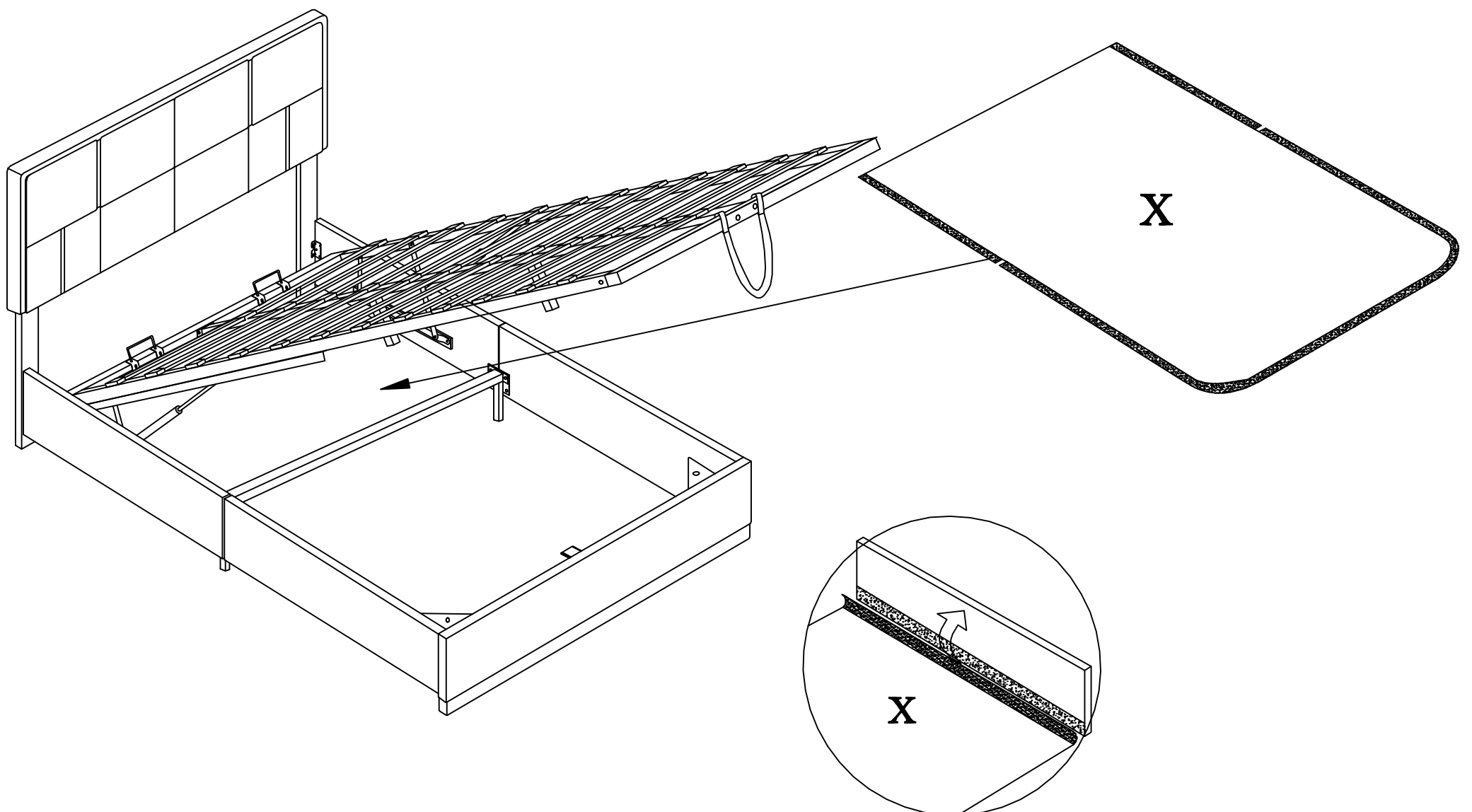



**STEP 13:**

